

1a

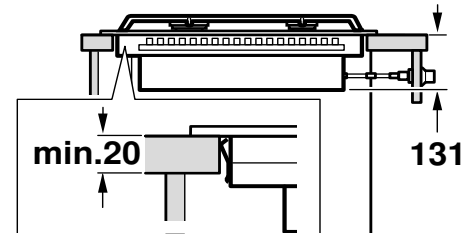

1b

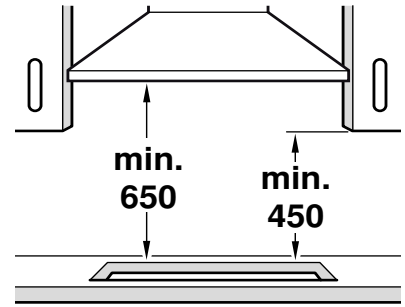
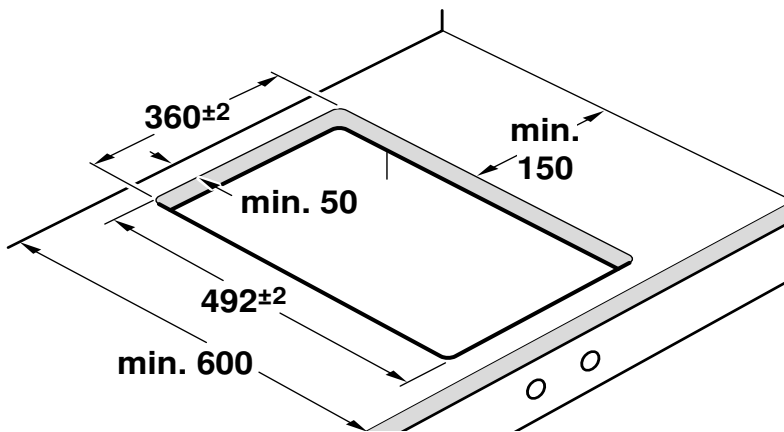
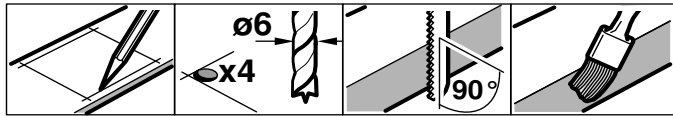
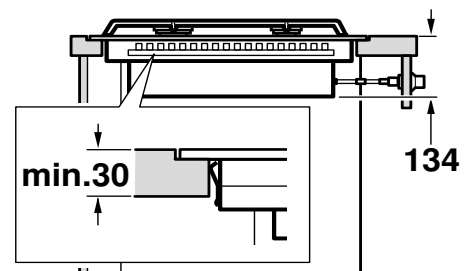
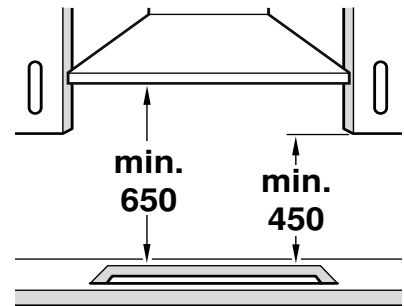
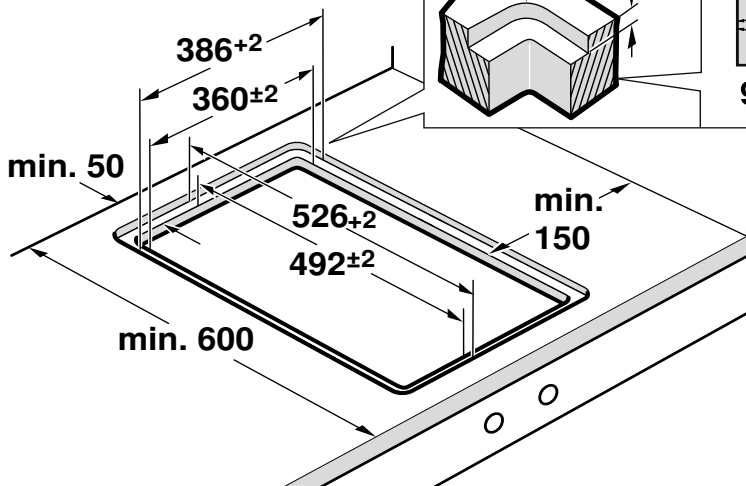
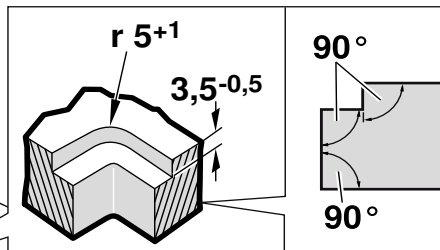

1c

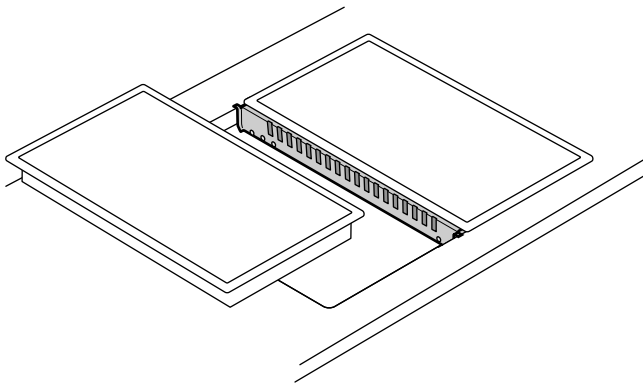

VA 420 000/001/010/011

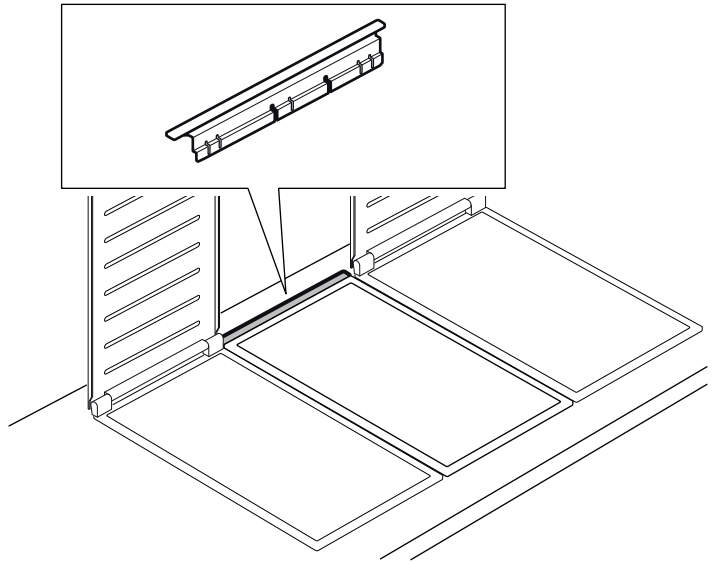

VA 450 110/-400/-600/-800/-900

1d

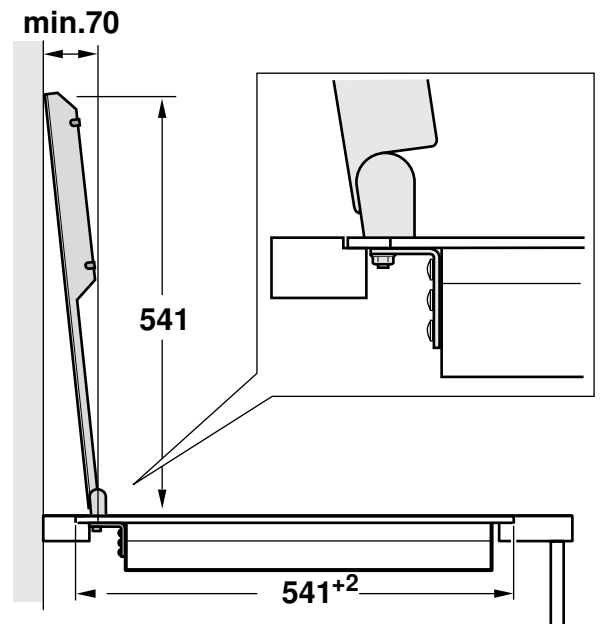
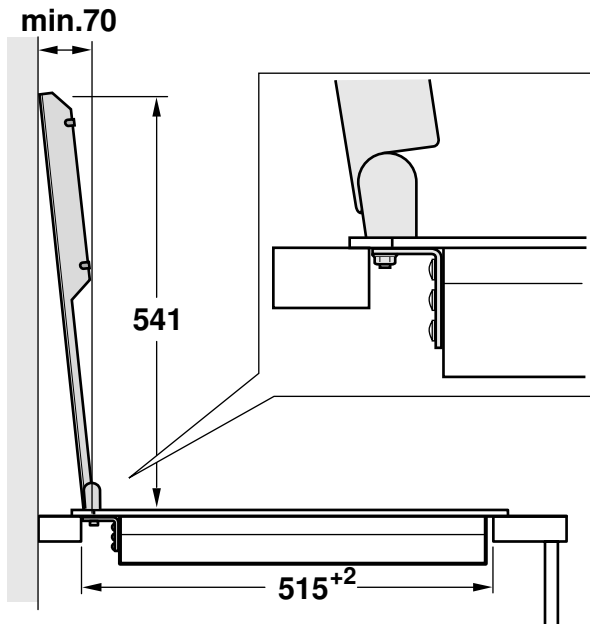

1e

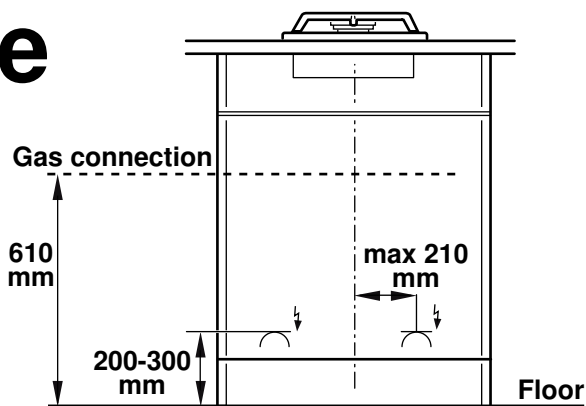

2a

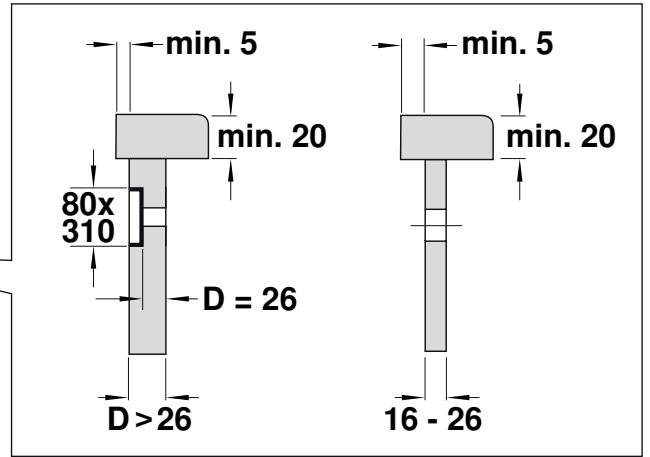
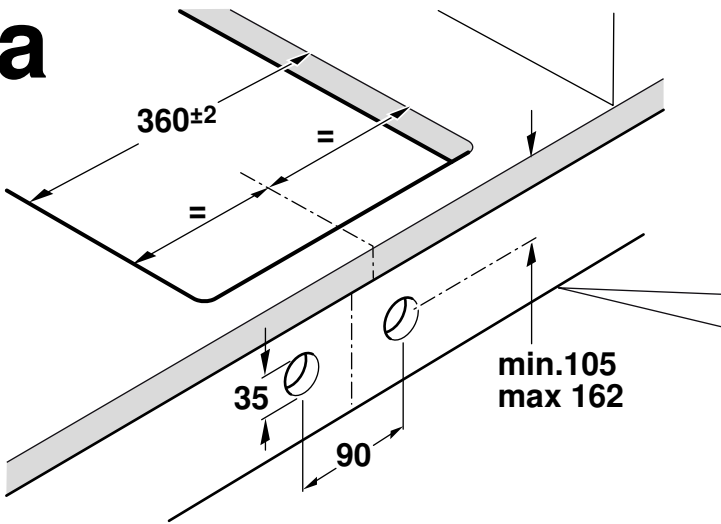

2b

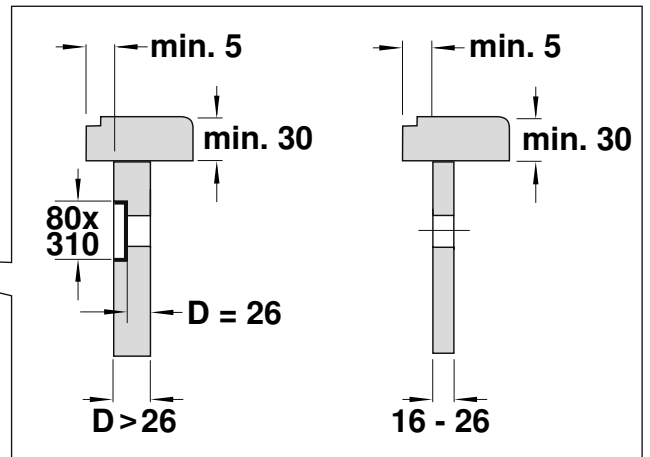
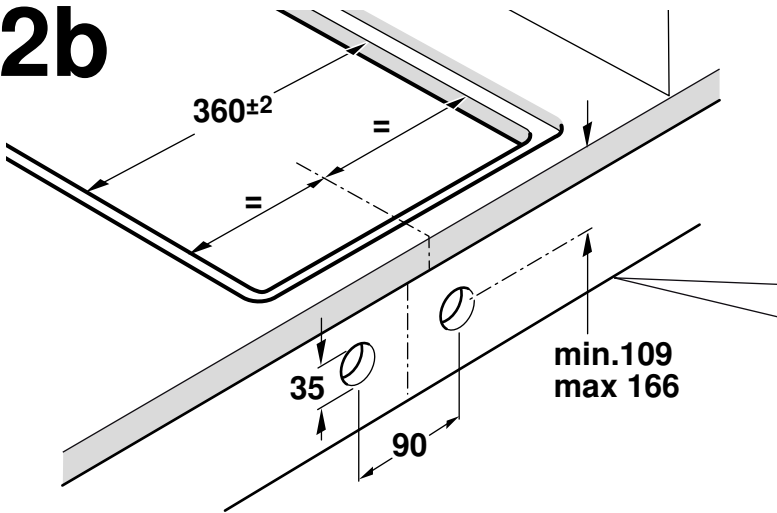

3

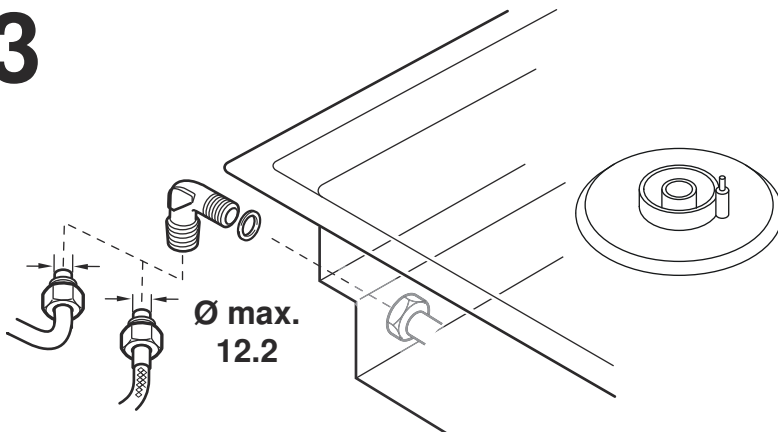

4

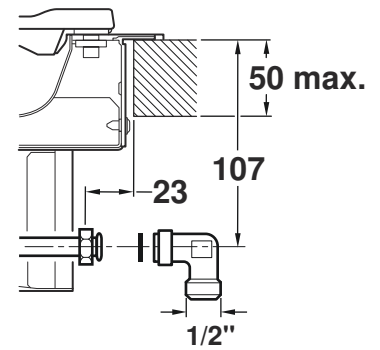

5

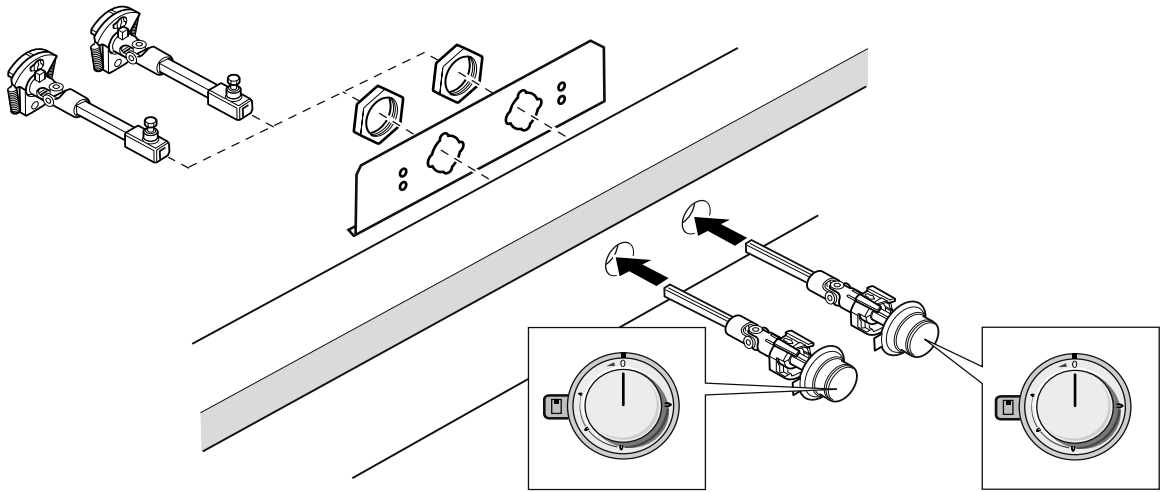

6a

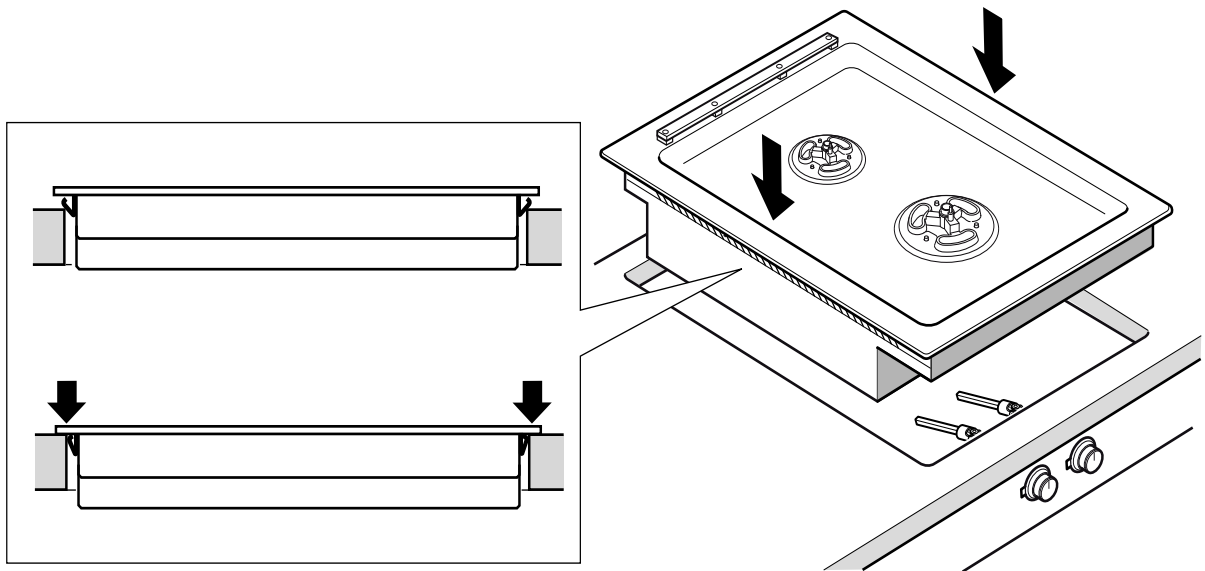

6b

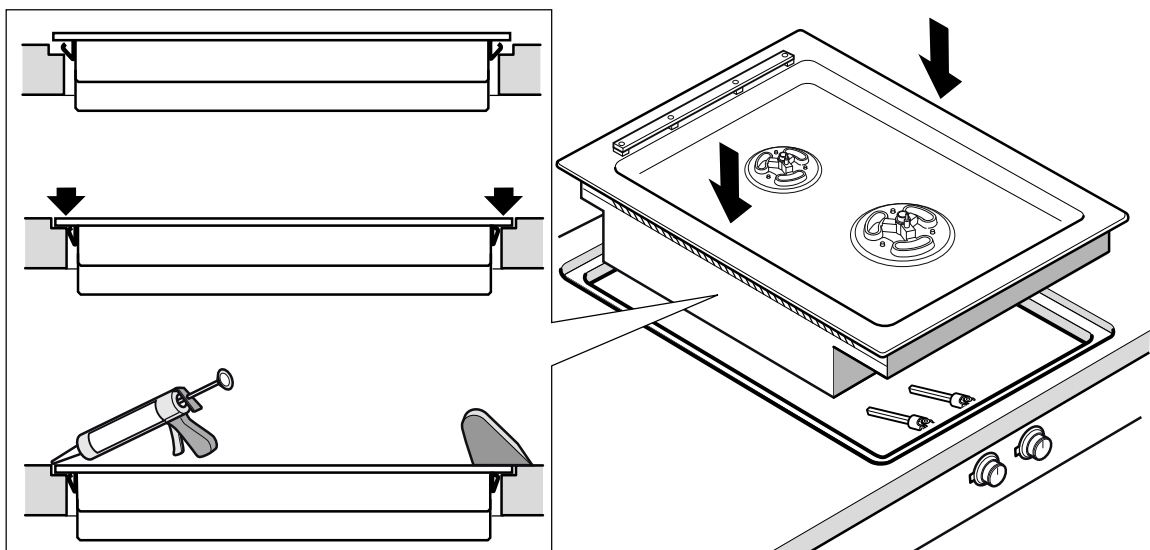

6c

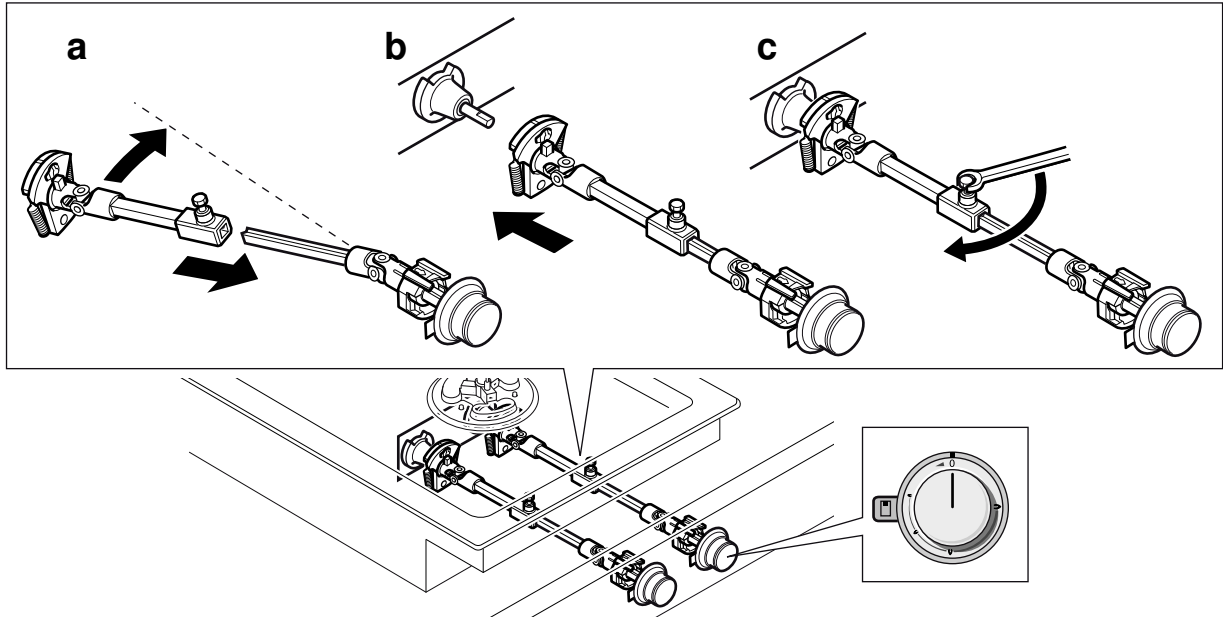



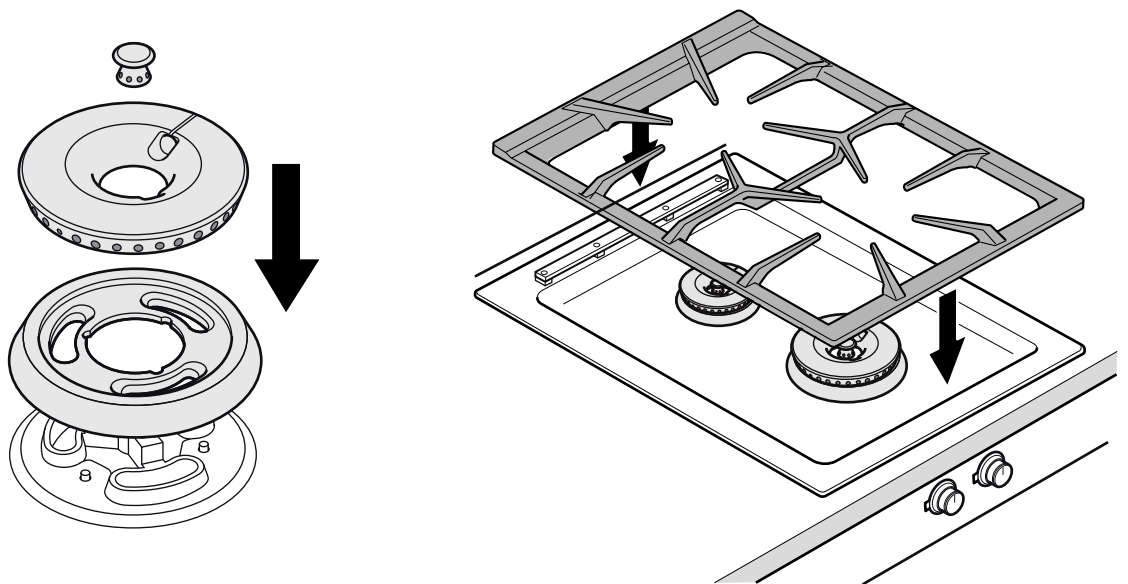



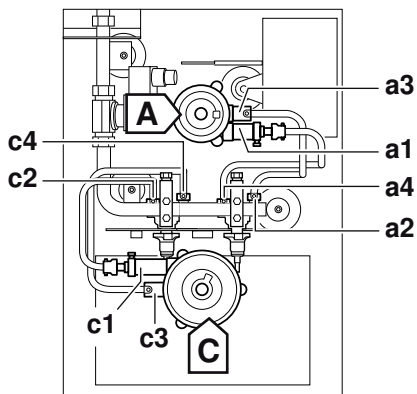

6d



7



A		Natural Gas N 1.0 kPA (10 mbar)	ULPG/Propane 2,75 kPA (27,5 mbar)
	a1	113	68
	L1	4 mm	6 mm
	a2	57	34
	a3	42	29
	a4	42	28
	L2	open	open

C		Natural Gas N 1.0 kPA (10 mbar)	ULPG/Propane 2,75 kPA (27,5 mbar)
	c1	168	105
	L1	6 mm	2 mm
	c2	70	45
	c3	42	29
	c4	42	28
	L2	open	open

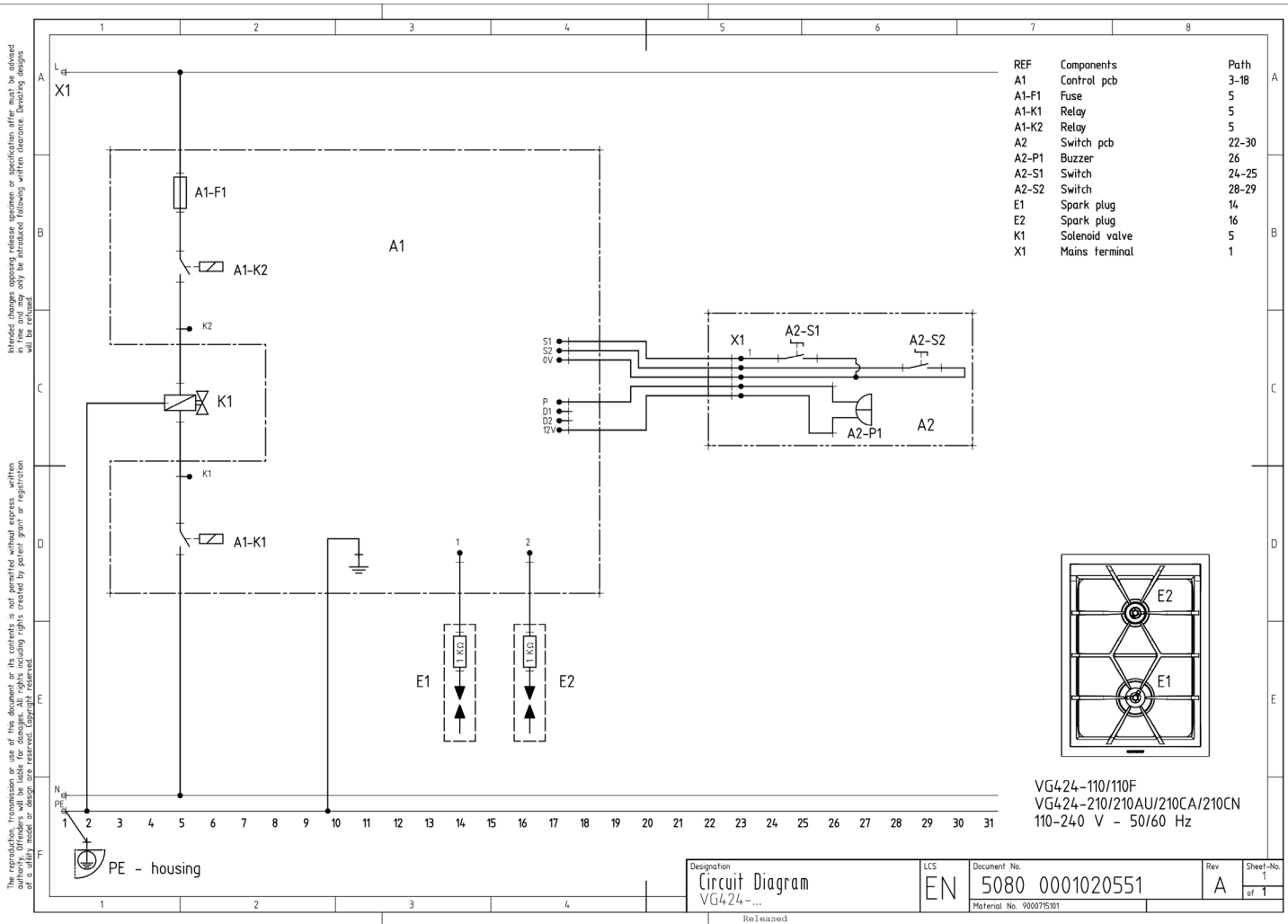
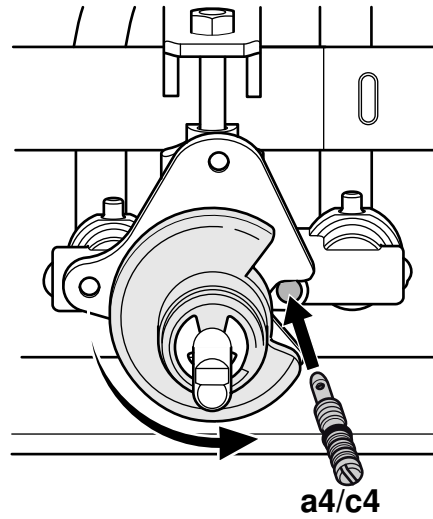
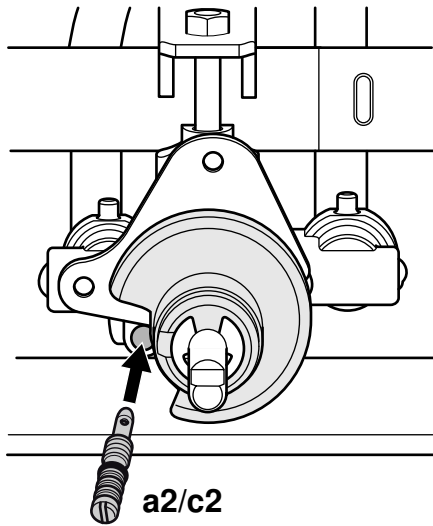

Important notes

Read these instructions carefully and keep them in a safe place. Safety during use can only be ensured if the appliance is fitted correctly according to these installation instructions. The installer is responsible for ensuring that the appliance operates perfectly at the point of installation.

The appliance must be connected to the mains only by an authorised person.

Before carrying out any type of work, turn off the electricity and gas supply.

Statutory regulations

This appliance shall be installed in accordance with the manufacturer's installation instructions, local gas fitting regulations, municipal building codes, electrical wiring regulations and AS/NZS 5601.1 the Australian Standard for gas installations. Refer also to AS/NZS 5601.1 for pipe sizing tables.

Before connecting the appliance, please check whether the local connection conditions such as the gas type, gas pressure and mains voltage and the appliance settings are correct. Refer to the data plate located on the hob base for the necessary information. If the data plate does not agree with the appliance settings refer to SampfordIXL contact details.

For conversion to another type of gas, please call the after-sales service.

⚠ Risk of gas escape!

After connecting the appliance to the gas supply, always check the connection for leak tightness. The manufacturer accepts no responsibility for the escape of gas from a gas connection which has been previously tampered with.

Ensure sufficient air exchange in the room where the appliance is installed. Up to 11 kW total output:

- Minimum volume of the room where appliance is installed: 20 m³
- A door leading to the open air or a window which can be opened.

Up to 18 kW total output:

- Minimum volume of the room where appliance is installed: 2 m³ per kW total output.
- A door leading to the open air or a window which can be opened.
- An extraction hood into the open air. Minimum displacement volume of extraction hood: 15 m³/h per kW total output.

The installation system must incorporate an all-pin isolating switch with a contact opening of at least 3 mm, or the appliance should be connected to the mains via a safety plug. The plug must remain accessible after installation is complete.

Do not kink or trap the mains connection cable.

The appliance must be fitted according to the installation drawing. A minimum clearance of **260 mm** from the periphery of the burner to a rear or side horizontal combustible surface must be maintained. **If clearance is less than 260 mm** then that surface must be non-combustible or be protected in accordance with AS/NZS 5601.1 clause 6.10.1.2

Overhead clearances

Rangehoods and exhaust fans shall be installed in accordance with the manufacturers instructions. However, in no case shall the clearance between the highest part of the burner and the underside of the rangehood be less than **650 mm** or for a overhead exhaust fan, **750 mm**.

This appliance is not intended for operation with an external timer or an external remote control.

Do not install this appliance on boats or in vehicles.

Special accessories

You can order the following special accessories from your specialist dealer:

AA 414 010	Ventilation molding for operation next to downdraft ventilation VL 414
SV 402 090	Spindle extension up to 140 mm
SV 402 205	Spindle extension up to 300 mm
VA 420 000	Connection strip for combination with other Vario 400 appliances for flush installation
VA 420 001	Connection strip for combination with other Vario 400 appliances for flush installation with appliance cover/extension

VA 420 010 Connection strip for combination with other Vario 400 appliances for surface installation

VA 420 011 Connection strip for combination with other Vario 400 appliances for surface installation with appliance cover/extension

VA 440 010 Stainless steel appliance cover

VA 450 400 Appliance extension, 38 cm

Only use the accessories as specified. The manufacturer accepts no liability if these accessories are used incorrectly.

Preparing the units (Fig.1a)

The kitchen unit must be heat-resistant to at least 90 °C (about 190 °F). The stability of the unit must be maintained after producing the cut-out.

Produce the cut-out in the worktop for one or more Vario appliances as shown in the installation sketch. The angle between the cut surface and the worktop must be 90 °.

The cut edges at the sides must be flat to ensure a good fit of the retaining springs on the appliance. In laminated worktops, it may be necessary to fit strips at the sides of the cut-out.

Remove shavings after cutting. Seal cut surfaces for resistance to heat and so they are watertight.

Pay attention to a minimum gap of 10 mm from the underside of the appliance to kitchen units.

Use suitable base constructions to ensure load-carrying capacity and stability, especially in the case of thin worktops. Pay attention to the weight of the appliance, including any payload.

Reinforcement material used must be resistant to heat and moisture.

Note: Wait until the appliance has been installed in the installation opening before checking that it is level.

Installation flush with surrounding surfaces (Fig. 1b)

It is possible to fit the appliance into a worktop such that it is flush with the worktop surface.

The appliance can be installed in the following temperature- and water-resistant worktops:

- Granite worktops
- Plastic worktops (e.g. Corian®)
- Solid wood worktops: Only on agreement with the worktop manufacturer (seal the cut-out edges)
- For other worktop materials, contact the worktop manufacturer about their use.

The appliance cannot be installed in compressed-wood worktops.

Note: All cut-outs in the worktop are to be carried out in a specialist workshop in accordance with the installation diagram. Each cut-out must be neat and precise as the cut edge is visible on the surface. Clean and degrease the cut-out edges with a suitable cleaning agent (follow the instructions from the silicone manufacturer).

Combining multiple Vario appliances (Fig. 1c)

The connecting strip VA 420 000/001/010/011 is required in order to combine multiple Vario appliances. This can be ordered separately as an optional accessory. When making the cut-out, allow extra space for the connecting strip between the appliances (see installation instructions VA 420 000/001/010/011).

Appliances can also be fitted in their own individual cut-outs as long as at least 50 mm of material is left between the cut-outs.

To enable combination of appliances with and without an appliance cover, dimension differences can be balanced out by the extension VA 450 110/-400/-600/-800/-900 (depending on appliance width).

Combination with the appliance cover (Fig. 1d)

You can order the appliance cover VA 440 010 as a special accessory. Allow for the additional space required for the appliance cover when producing the cut-out.

Boring to fit the control knobs (Fig. 2a + 2b)

Thickness of cabinet front: 16 - 26 mm

1. As shown in the installation sketch, drill the Ø 35 mm holes to secure the control knobs in the cabinet front. Attach the enclosed stencil to the cabinet front for correct positioning of the bore.
2. If the cabinet front is thicker than 26 mm, the front must be routed from the back to max. 26 mm on an area of 80 x 310 mm.

Fitting the appliance

1. Lower the appliance evenly into the cut-out and press down firmly (Fig. 6a).

Note: The appliance should fit tightly in the cut-out without moving around (e.g. during cleaning). If the cut-out width is on or above tolerance limit it may be necessary to fit filler strips to the sides of the cut-out.

2. Turn control knobs to the OFF position. Assemble the spindle between the control knob and the gas tap. Firmly slide the spindle drive onto the gas tap. Fix the spindle in position with the retaining screw (Fig. 6c).
3. Connect the appliance to the power and gas supply and test for correct functioning. There might be an air pocket in the gas supply line if the appliance switches off. Turn control knobs off and switch on again. Repeat until burner ignites.

4. **Only for flush fitting (Fig. 6b): Check appliance for correct functioning before applying sealant!** Fill the surrounding gap between the work surface and the frame with a suitable, heat-resistant silicone adhesive (e.g. OTTOSEAL® S 70). Smooth the sealing joint using the smoothing agent recommended by the silicone manufacturer. Check the usage information for the silicone adhesive. Do not use the appliance until the silicone adhesive has completely dried (at least 24 hours depending on room temperature).

Caution!

Unsuitable silicone adhesives can cause permanent discolouration on work surfaces made from natural stone.

Removing the appliance

Disconnect the appliance from the power and the gas supply. For flush-mounted appliances, remove the silicone joint. Push out the appliance from below.

Caution!

Damage to appliance! Do not lever out the appliance from above.

Gas connection

The supply connection point shall be accessible with the appliance installed.

Using the R $\frac{1}{2}$ " (for appliance side) connection elbow provided, connect the appliance with the associated gasket to a fixed connection pipe. For natural gas the regulator must be connected.

If using a flexible connection

This appliance is approved for connection by a CLASS B hose. Connection is in compliance with AS/NZS 5601.1

There are two ways to carry out the connection to the main gas line:

- A: The hotplate can be connected with rigid pipe.
- B: Flexible Hose: If installing with a hose assembly, install with a hose assembly that complies with AS/NZS 1869 (AGA Approved), 10 mm ID, class Bor D, no more than 1.2 m long and in accordance with AS/NZS 5601.1. Ensure that the hose does not contact the hot surfaces of the hotplate, oven, dishwasher or any other appliance that may be installed underneath or next to the hotplate. The hose should not be subjected to abrasion, kinking or permanent deformation and should be inspected along its entire length with the cooktop in the installed position. Unions compatible with the hose fittings must be used and all connections tested for gas leaks.

Before leaving - check all connections for gas leaks with soap and water. DO NOT use a naked flame for detecting leaks. Ignite all burners both individually and concurrently to ensure correct operation of gas valves, burners and ignition. Turn gas taps to low position and observe stability of the flame for each burner individually and all together.

Adhere the duplicate data plate to an accessible location near to the cook top. When satisfied with the cook top, please instruct the user on the correct method of operation. In case the appliance fails to operate correctly after all checks have been carried out, refer to the authorised service provider in your area.

Electrical connection

Check that the appliance has the same voltage and frequency as the electrical installation system.

The hob is delivered with a mains cable and 3 pin moulded plug.

Only connect the appliance to sockets which have been fitted and earthed according to regulations.

The appliance corresponds to type Y: the mains connection cable must only be replaced by the after-sales service. Check the cable type and minimum cross section.

Technical data

Total connected load (ULPG):

22.2 MJ/hr (6.2 kW)

Total connected load (natural gas):

20.5 MJ/hr (5.7 kW)

Total connected load electric: 25 VA

Conversion to another type of gas

This gas hob corresponds to the categories specified on the rating plate. It is possible to convert the appliance to any of the gases listed on the plate by changing the nozzles. The modification kit can be ordered via our after-sales service. Depending on the model the parts required may be included in the scope of delivery.

The conversion must be carried out by an authorised person.

Before carrying out the conversion, turn off the electricity and gas supply.

Changing the low burn nozzle (Fig. 8)

1. Remove pan supports and all burner parts.
2. Unscrew fastening screws (three 7 mm nuts on each burner) and carefully detach stovetop. Loosen the screws of the spindle cover. Remove the right half of the cover. Then slide the remaining half to the right and remove the cover.
3. Loosen the retaining screw on the spindles and pull off the spindle drive from the gas tap. Unscrew and remove the cover on the gas tap.
4. The low burn nozzles are located in the gas tap and are screwed in from the front. Turn the plastic part so that the recess is above the nozzle. Screw out nozzle and take nozzle out with small pliers.
5. Insert the new nozzles as specified in the nozzle table. The nozzles must be screwed in fully.
6. Firmly slide the spindle drive onto the gas tap. Fix the spindle in position with the retaining screw. Fit the spindle covers.

Changing the full burn nozzle: normal and large burner (Fig 9)

1. Remove securing clips on the burner pipes. Remove burner pipes. Leave the electrode connected. Unscrew burners (Torx T20) and pull off the burners from the burner pipes.
2. Remove nozzles and O-ring by hand.
3. Check that O-ring is correctly positioned in new full-burn nozzles. Push nozzles onto burner pipes. Do not bend burner pipes!
4. Push the burners onto the supply lines. Put on securing clips. Screw the burners back on.
5. Set air-regulating tube of the outer burner ring to correct dimension after loosening the screw (see nozzle table - L1). Tighten screw again.
6. Slide or turn air-regulating tube of the inner burner ring to correct dimension (see nozzle table - L2).
7. Put stovetop in place and screw it tight. Put burner parts and pan support in place, positioning them correctly.

Checking functions after the conversion:

The flames are adjusted correctly if no yellow tips are visible and if they do not go out when switching over swiftly from the high to the low setting.

Note: stick the adhesive label included with the nozzle set over the rating plate of the appliance to document the changeover to a different gas type.