

VG 414 210 AU

Gas wok

Table of contents

Safety information	3
WHAT TO DO IF YOU SMELL GAS	4
Causes of damage	4
Environmental protection	5
Environmental protection	5
Tips for saving energy	5
Your new appliance	6
Gas Wok	6
Control knob	6
Special accessories	6
Burner assembly	7
Operation	7
Switching on	7
Electronic flame detection and automatic re-ignition	8
Switching off	8
Safety shut-off	8
Settings table and tips	8
Tips for cooking and roasting	8
Cooking in the wok	8
Cookware recommendations	9
Suitable cooking vessels	9
Precautions for use	9
Care and cleaning	10
Cleaning the appliance	10
Cleaning the electrode	10
Burnt-in residues	11
Discolouration of burners	11
Trouble shooting	12
After-sales service	13

Additional information on products, accessories, replacement parts and services can be found at www.gaggenau.com and in the online shop www.gaggenau-eshop.com

⚠ Safety information

PLEASE READ THIS MANUAL BEFORE INSTALLING AND USING THIS COOKTOP.

This cooker is approved for use with Natural and Propane gases. Leave instructions with the owner.

This appliance must be installed according to the installation instructions included.

Check the appliance for damage after unpacking it. Do not connect the appliance if it has been damaged in transport.

Only allow a licensed professional to connect the appliance. Damage caused by incorrect connection is not covered under warranty. Call the after-sales service if you want to convert your appliance to a different type of gas.

This appliance is intended for domestic use and the household environment only. This appliance must only be used to prepare food and drinks and must never be used as a heater. Do not leave the appliance unattended during operation. Only use the appliance indoors.

This appliance is not intended for operation with an external clock timer or a remote control.

This appliance may be used by children over the age of 8 years old and by persons with reduced physical, sensory or mental capabilities or by persons with a lack of experience or knowledge if they are supervised or are instructed by a person responsible for their safety how to use the appliance safely and have understood the associated hazards.

Children must not play with the appliance. Children must not clean the appliance or carry out general maintenance unless they are at least 8 years old and are being supervised. Keep children below the age of 8 years old at a safe distance from the appliance and power cable.

Risk of asphyxiation!

The use of a gas cooker leads to a build-up of heat, moisture and products of combustion in the room where the appliance is installed. Ensure that the installation room is well ventilated. The natural ventilation openings

must be kept open or a mechanical ventilation device must be provided (e.g. an extractor hood). Intensive and persistent use of the appliance may mean that it is necessary to have additional ventilation (e.g. opening a window), or more effective ventilation (e.g. operating the existing mechanical ventilation device at a higher setting).

Do not spray aerosols in the vicinity of this appliance while it is in operation.

Where this appliance is installed in a marine craft or in a caravan, for safety reasons it shall not be used as a space heater.

Unsuitable for use in a marine craft, caravan or mobile home, unless each burner is fitted with a flame guard.

Do not modify this appliance.

Close the safety valve on the gas supply line if the cooker will not be used for a prolonged period.

Risk of fire!

- Hot oil and fat can ignite very quickly. Never leave hot fat or oil unattended. Never use water to put out burning oil or fat. Switch off the hotplate. Extinguish flames carefully using a lid, fire blanket or something similar.
- The appliance becomes very hot and flammable materials could catch fire. Never store or use flammable objects (e.g. spray cans, cleaning agents) under the appliance or in its immediate vicinity. Never place flammable items on or in the appliance.
- When gas hotplates are in operation without any cookware placed on them, they can build up a lot of heat. The appliance and the extractor hood above it may become damaged or be set on fire. Grease residue in the filter of the extractor hood may ignite. Only operate the gas burners with cookware on them.

Risk of burns!

- The accessible parts become very hot when in operation. Never touch hot parts. Keep children at a safe distance.
- When the appliance cover is closed, heat will accumulate. Only close the appliance cover when the appliance has cooled

down. Never switch the appliance on with the appliance cover closed. Do not rest food on the appliance cover or use it to keep food warm.

- Empty cookware becomes extremely hot when set on a gas hotplate that is in operation. Never heat up empty cookware.
- If the liquefied gas bottle is not upright, liquefied propane/butane can enter the appliance. Intense darting flames may therefore escape from the burners. Components may become damaged and start to leak over time so that gas escapes uncontrollably. Both can cause burns. Always use liquefied gas bottles in an upright position.
- The accessible parts become hot during operation. Never touch the hot parts. Keep children at a safe distance.

Risk of injury!

- Incorrect repairs are dangerous. Repairs may only be carried out, and damaged power and gas lines replaced, by an after-sales engineer trained by us. If the appliance is faulty, unplug the mains plug or switch off the fuse in the fuse box. Shut off the gas supply. Contact the after-sales service.
- Faults or damage to the appliance are dangerous. Never switch on a faulty appliance. Unplug the appliance from the mains or switch off the circuit breaker in the fuse box. Shut off the gas supply. Contact the after-sales service.
- Unsuitable pan sizes, damaged or incorrectly positioned pans can cause serious injury. Observe the instructions which accompany the cookware.

Risk of electric shock!

- Incorrect repairs are dangerous. Repairs may only be carried out by one of our trained after-sales engineers. If the appliance is faulty, unplug the mains plug or switch off the fuse in the fuse box. Contact the after-sales service.
- The cable insulation on electrical appliances may melt when touching hot parts of the appliance. Never bring

electrical appliance cables into contact with hot parts of the appliance.

- Penetrating moisture may cause an electric shock. Do not use any high-pressure cleaners or steam cleaners.
- A defective appliance may cause electric shock. Never switch on a defective appliance. Unplug the appliance from the mains or switch off the circuit breaker in the fuse box. Contact the after-sales service.

WHAT TO DO IF YOU SMELL GAS

- Do not light any appliance.
- Do not touch any electrical switch; do not use any phone in the building.
- Immediately call your gas supplier from a neighbour's phone. Follow the gas supplier's instructions.
- If you cannot reach your gas supplier, call the fire department.

Installation and service must be performed by an authorised person.

Causes of damage

Caution!

- Heat damage to adjacent appliances or kitchen units: Heat and moisture are produced if the appliance is operated over a prolonged period. Additional ventilation is required. Open windows and switch on an extraction hood which conducts into the open air.
- Appliance damage caused by heat accumulation: Do not heat roasting dishes, pans or grill stones on more than one burner at the same time.
- Malfunction: Always turn control knobs to the OFF position when the appliance is not in operation.

Environmental protection

Unpack the appliance and dispose of the packaging in an environmentally-responsible manner.

Environmental protection



This appliance is labelled in accordance with the European Directive 2012/19/EU concerning used electrical and electronic appliances (WEEE – waste electrical and electronic equipment). The guideline determines the framework for the return and recycling of used appliances as applicable.

Tips for saving energy

- Use pots or pans which are the right size for each burner.
- Always centre the pot or pan over the burner.
- Do not cook without using a lid and make sure the lid is properly fitted.

Your new appliance

Your new appliance and its accessories are described in this section.

Gas Wok

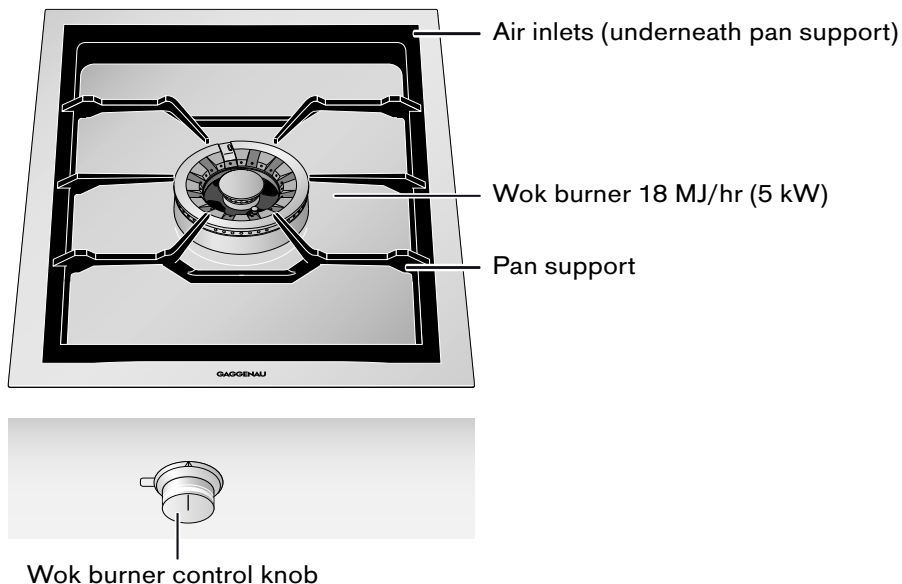

Control knob

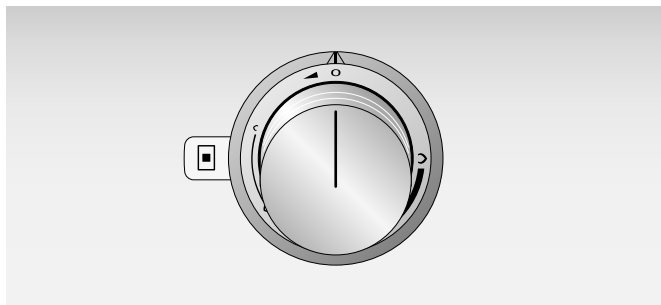

The markings show the setting between high and low heat. The flame setting is infinitely variable between high and low.

Special accessories

You can order the following special accessories from your specialist dealer:

- AA 414 010 Ventilation molding for operation next to downdraft ventilation VL 414
- WP 400 001 Multi-layer material wok pan, with curved base and handle, Ø 36 cm, 6 litres volume, 10 cm high.
- SV 401 090 Spindle extension up to 140 mm
- SV 401 205 Spindle extension up to 300 mm

- VA 420 000 Connection strip for combination with other Vario 400 appliances for flush installation
- VA 420 001 Connection strip for combination with other Vario 400 appliances for flush installation with appliance cover/extension
- VA 420 010 Connection strip for combination with other Vario 400 appliances for surface installation
- VA 420 011 Connection strip for combination with other Vario 400 appliances for surface installation with appliance cover/extension
- VA 440 010 Stainless steel appliance cover
- VA 450 400 Appliance extension, 38 cm

Only use the accessories as specified. The manufacturer accepts no liability if these accessories are used incorrectly.

Burner assembly

Always assemble the burner parts correctly and evenly to avoid faults during ignition or during use. When assembling the burner parts, make sure that the burner head is placed on the base in such a way that the electrode is positioned in the opening on the burner head. The catching pin on the burner ring must fit in the corresponding groove on the burner head.

Wok burner assembly

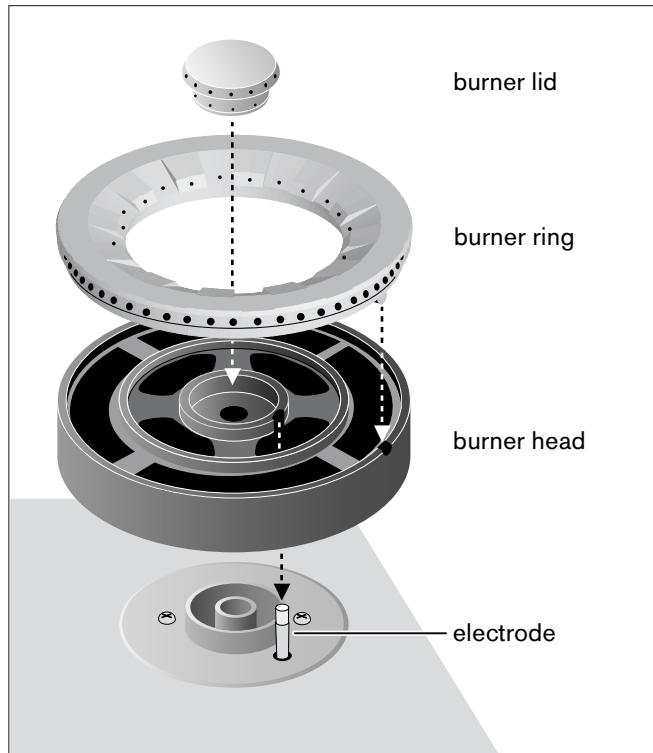

Operation

The markings show the position of the corresponding burner and the setting between high and low heat. The flame setting is infinitely variable between high and low heat.

Notes

- Only light a burner if all pan supports and burner parts are properly assembled.
- Make sure the burners and electrodes are clean and dry.
- Only use the recommended accessories. Do not cover the stainless steel cooktop base (e.g. with aluminium foil).
- Do not cover the air inlet at the back of the cooktop.

Abnormal operation

Flames are usually blue and sharply defined. If the flames are yellowish or noisy or if the gas does not ignite within the period specified under "switching on" abnormal operation is indicated. Refer to chapter "After-sales service" of this manual for service contact details.

Caution! Heat damage to the extractor hood: Always switch on the extractor hood while the gas cooktop is in use. When using several cooking positions select a higher fan level on the extractor hood. Make sure there is a sufficient ventilation of the room.

Switching on

Your cooktop features automatic fast ignition.

- 1 Place a suitable pot or pan on the pan support.
- 2 Press down the control knob and turn it anticlockwise to the required position. The burner lights automatically.

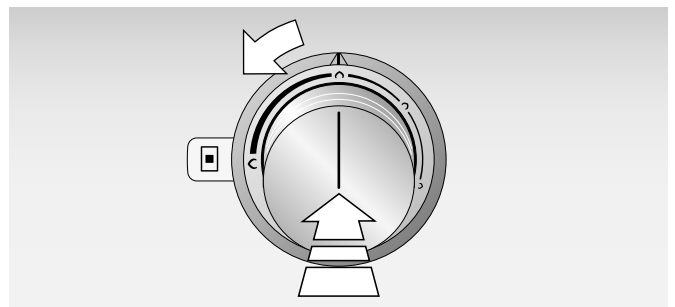

The flame size can be set continuously between high and low by slowly turning the control knob.

Notes

- When using large pots or pans you should ignite the burner in the low position.
- Every time the gas hob is switched on, the electronics run an auto test. The electrode fires and the burner ignites after a few seconds.

- When being switched on, a short sound may be heard when the electronics of the gas hob open the gas supply valve. This is normal.
- The cooktop cannot be used during a power failure.

Electronic flame detection and automatic re-ignition

For your safety the cooktop features electronic flame monitoring. Should the flame go out during operation (e.g. because of a draught), the appliance will automatically re-ignite the burner.

Should the re-ignition be unsuccessful (e.g. burner is soiled by spilled over food or liquid), the gas supply is switched off and a signal is sounded.

The flashing indicator lights will go out except for the affected burner. This indicator will continue to flash for a few seconds.

Turn the control knob to the OFF position. After the appliance has cooled down sufficiently, check this burner to see if all the burner parts have been assembled correctly. Check if the burner or the electrode has been soiled (see trouble shooting guide).

Please note when switching on the cold appliance on the HIGH setting:

Depending on the gas type and pressure, it is possible that the electrode continues to fire, although there is a flame visible, and then switches off. Turn the control knob to the OFF position and then to the LOW setting. Leave to warm up for 30 to 60 seconds after ignition. Then you can continue to use your appliance as usual.

Switching off

Fully turn the control knob to the OFF position. The electronics of the appliance switches the gas supply off.

Risk of burns!

When the appliance cover is closed, heat will accumulate. Only close the appliance cover when the appliance has cooled down. Never switch the appliance on with the appliance cover closed. Do not rest food on the appliance cover or use it to keep food warm.





Safety shut-off

For your protection, the appliance has a safety shut-off feature. The appliance switches off after six hours if it is not operated during this time.

Even after a power outage, the appliance stays switched off. A prolonged audible signal is sounded.

Turn the control knob to 0. You can then operate the appliance in the way to which you are accustomed.

Settings table and tips

Cooking level	Cooking method	Examples
High heat 	Boiling	Water
	Searing	Meat
	Heating	Fat, liquids
	Boiling	Soup, sauce
	Blanching	Vegetables
From  to 	Roasting	Meat, fish, potatoes
	Baking	Pancakes, egg dishes
	Simmering in open pot	Dumplings, sausages, beef for making soup
	Simmering	Sweet sauces, sauces
	Boiling with closed lid	Soup, potatoes
	Steaming	Vegetables, fish
	Stewing	Vegetables, fruit, fish
	Braising	Goulash, roasts, vegetables
Low heat 	Thawing	Frozen foods
	Slow cooking	Rice, pulses
	Reheating	Soup, casserole, vegetables in a sauce

Tips for cooking and roasting

The values given in the settings table must be looked upon as recommended values. The heat required depends not only on the type and condition of the food, but also the size and contents of the pot.

Due to the high performance of the cooktop, fat and oil will heat up quickly. Never leave the cooktop unattended, fat can ignite, food can burn.

Cooking in the wok

We recommend using a round-bottom wok. You can order a high-quality wok pan as a special accessory (WP 400 001).

Only use oil that is suitable for frying at high temperatures, for example peanut oil.

Fry the food quickly on a high heat while stirring continuously. Vegetables should stay crispy.

Use a heat resistant, flat ladle with a long handle to stir the food and take it out of the wok pan.

Cookware recommendations

The following tips can help you save energy and avoid damage to your cookware.

Suitable cooking vessels

Burner	Pot base, recommended diameter	Pot base, minimum diameter
Wok burner	240 - 320 mm	160 mm

Pots with a diameter of less than 160 mm or more than 320 mm should not be used. When using large pots, pay attention that the pot does not protrude over the edge of the appliance.

Precautions for use

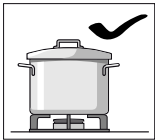

Use pots or pans which are the right size for each burner.

Do not use small pots or pans on large burners. The flame should not touch the sides of the pot.

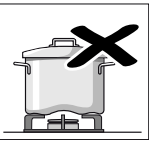
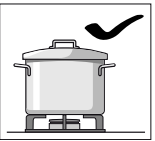

Do not use damaged pots or pans, which do not sit evenly on the cooktop, they may tip over.

Only use pots or pans with a thick, flat base.

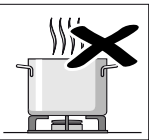
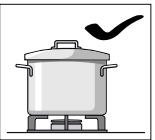

Do not cook without using a lid and make sure the lid is properly fitted. This wastes energy.

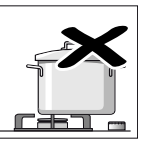
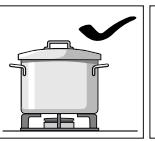

Always centre the pot or pan over the burner, otherwise it could tip over.

Do not place large pots on the burners near the control knobs. These may get damaged by the high temperatures.

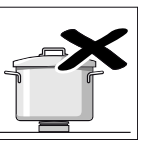
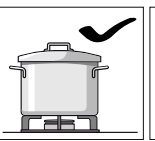

Place the pots or pans on the pan support, never directly on the burner.

Make sure that the pan supports and burner caps are correctly positioned before using the appliance.

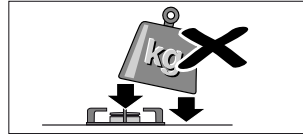

Pots or pans should be placed on the cooktop carefully.

Do not strike the cooktop and do not place excessive weight on it.

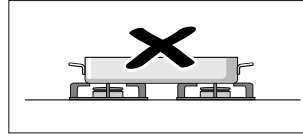

Do not heat a cooking vessel (e.g. roaster, pan, grill stone) on more than one burner at the same time. The resulting heat accumulation will damage the appliance.

Care and cleaning

In this chapter you will find tips on how to maintain and clean your cooktop correctly.

⚠ Risk of electric shock!

Penetrating moisture may cause an electric shock. Do not use any high-pressure cleaners or steam cleaners.

⚠ Risk of burns!

The accessible parts become very hot when in operation. Never touch hot parts. Keep children at a safe distance.

Caution! Risk of surface damage: Do not use these cleaners

- harsh or abrasive cleaning agents
- oven cleaners
- corrosive or aggressive cleaners, or those containing chlorine
- cleaning agents with a high alcohol content
- hard and scratchy sponges, brushes or scouring pads

If such an agent comes into contact with the appliance, wash it off immediately with water. Thoroughly wash out new sponge cloths before using them!

Caution! Be careful when removing or fitting the pan support in order to avoid scratching the cooktop. Lift the pan supports with both hands.

Cleaning the appliance

Clean the appliance after every use once it has cooled down. Remove spills immediately. Burnt in residues may be difficult to remove.

Keep the air inlets underneath the pan support clean. Do not cover the air inlets.

Make sure the burner parts are dry before assembly. Only operate the appliance with all parts dry. Damp burner parts will cause malfunctions when igniting or unstable flames.

When assembling the burner parts, make sure they are properly positioned (catching pin). Make sure all burner parts lie evenly flat.

Part/surface	Recommended cleaning method
Stainless steel surfaces	Clean with soapy water – dry with a soft cloth. Do not use too much water to avoid water entering the appliance. Soak burnt-in remainders in a little water and detergent. Do not scrape away. To remove stubborn residues or yellowish discolouration because of the heat, you can order a stainless-steel cleaner (order number 311413).
Pan support	Carefully take off pan support for cleaning. Soak in soapy water. Clean with a brush and some detergent. Be careful when cleaning around the rubber rests to ensure they do not come loose. Rinse with clear water. Carefully dry pan support before assembly. Do not clean in a dishwasher!
Burner parts (brass)	Clean with soapy water – dry with a soft cloth. Port openings of the burner ring must be kept free. Be careful not to loose the small parts. Do not clean in a dishwasher!
Control knobs	Clean with soapy water – the cloth should not be too wet. Dry with a soft cloth.

Cleaning the electrode

A soiled electrode will cause malfunctions when igniting or during flame monitoring.

If necessary clean the electrode with the enclosed brush. To avoid damage clean the electrodes carefully, do not twist or damage the electrodes. **Do not switch on the gas cooker while cleaning the electrode.**

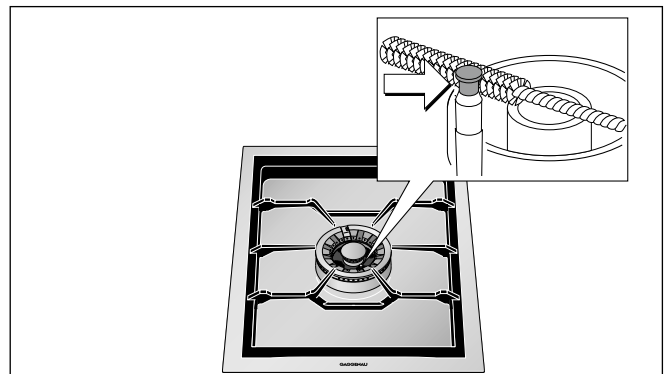

Burnt-in residues

To remove stubborn, burnt-in residues you can order the grill cleaning gel (order number 463582) from your specialist retailer or from our after-sales service. You can use it to clean the pan supports, the burner parts and the stainless steel cooktop base. If necessary apply the gel and leave overnight. Please observe the manufacturer's instructions.

Discolouration of burners

After long use, the brass burner parts turn darker due to natural oxidation. The color change doesn't affect use. Proceed as follows to eliminate this discoloration:

- 1 Prepare a solution of equal amounts of white vinegar with a maximum of 8% acid (typical household vinegar) and warm water.
- 2 Immerse the burner parts in the solution for a maximum of 10 minutes. Remove stubborn stains with a cloth or sponge.
- 3 Then rinse the burner parts thoroughly with clear water and dry them well prior to next use.

Caution! Too strongly concentrated solution or too long of contact with vinegar will damage the surface of burner parts!

Trouble shooting

Malfunctions often have simple explanations. Please read the following notes before calling the after-sales service.

Risk of electric shock!

Incorrect repairs are dangerous. Repairs may only be carried out by one of our trained after-sales engineers. If the appliance is faulty, unplug the mains plug or switch off the fuse in the fuse box. Contact the after-sales service.

Malfunction	Cause	Solution
Burner does not ignite when switched on.	No power supply.	Turn all control knobs to 0. Check in the fuse box whether the fuse has blown.
Burner does not ignite when switched on. Audible signal sounds.	Fault on the burner or the gas supply.	Turn all control knobs to 0. Check: <ul style="list-style-type: none"> ● Burner parts fitted correctly? ● Gas shut-off valve open? ● Burners dry and clean? ● Air in the line after first connection or a change of gas cylinder (liquid gas)? ● Gas cylinder empty (liquid gas)?
Burner goes off during operation. Audible signal sounds.	Fault on the burner or the gas supply.	Turn all control knobs to 0. Wait until the appliance has cooled down. Check: <ul style="list-style-type: none"> ● Burner parts fitted correctly? ● Electrode soiled (food remainders) or moist? ● Burner soiled by spillovers? ● Strong draught (e.g. open window directly behind the gas stovetop)? ● Gas cylinder empty (liquid gas)?
Burner goes off during operation. Audible signal continues to sound although all control knobs have been turned to 0.	Protection against overheating	Turn all control knobs to 0. Wait until the appliance has cooled down and the audible signal goes off.
Burner goes off during operation.	Power failure	Turn all control knobs to 0. Check the power supply. The burners do not reignite automatically after a power failure.
Turn the control knob to 0. The appliance tries to reignite and an audible signal sounds.	Technical defect	Notify Gaggenau customer service.
Burners go off during operation. An audible signal sounds.	Safety shut-off: appliance has not been operated in the past six hours.	Turn the control knob to 0 and then switch on again, if necessary.
There is a smell of gas in the kitchen.	Potential leak on connection of gas cylinder.	Check gas cylinder connection for leaks.
The corners of the appliance curve upwards slightly during operation.	The heat causes the cooktop's metal to expand.	This is normal. No curving is visible after cooling down.

After-sales service

In the event of repairs please contact our after-sales service. We are committed to find the best solution also in order to avoid an unnecessary call-out.

Please quote the E number (product number) and the FD number (production number) of your appliance when contacting the after-sales service. The rating plate bearing these numbers can be found on the bottom of the appliance. For future reference you can note the data of your appliance and the telephone number of our after-sales service below.

E-Nr.

FD-Nr.

After-sales service

Please note that calling out an after-sales service technician is not free of charge, even within the warranty period, should the problem result from an operating error.

Risk of electric shock!

Incorrect repairs are dangerous. Repairs may only be carried out by one of our trained after-sales engineers. If the appliance is faulty, unplug the mains plug or switch off the fuse in the fuse box. Contact the after-sales service.

Please find the contact data of all countries in the enclosed customer service list.

To book an engineer visit and product advice

GB 0844 89289988

Calls from a BT landline will be charged at up to 3 pence per minute. A call set-up fee of up to 6 pence may apply.

IE 01450 2655

0.03 € per minute at peak. Off peak 0.0088 € per minute.

AU 1300 727 421

NZ 09 477 0492

Trust the expertise of the manufacturer, and rest assured that the repair will be carried out by trained service technicians using original spare parts for your domestic appliance.

Gaggenau Hausgeräte GmbH
Carl-Wery-Straße 34
D-81739 München
www.gaggenau.com

GAGGENAU



9000709165 en (930709)