

# VG 415 211 AU

Gas wok

---

## Table of contents

---

<b>Intended use</b>	<b>3</b>
<b>Important safety information</b>	<b>4</b>
<b>Causes of damage</b>	<b>6</b>
<b>Environmental protection</b>	<b>6</b>
Saving energy	6
Environmentally-friendly disposal	6
<b>Familiarising yourself with your appliance</b>	<b>7</b>
Gas hob	7
Control knob	7
Visual signals of the luminous disc	7
Special accessories	7
Individual parts of the wok burner	8
<b>Operating the appliance</b>	<b>8</b>
Switching on	9
Simmer setting	9
Electronic flame monitoring and automatic re-ignition	9
Switching off	9
Residual heat indicator	9
Safety shut-off	9
<b>Table of settings and tips</b>	<b>10</b>
Tips for cooking and roasting	10
Tips for using a wok	10
<b>Information and tips regarding cookware</b>	<b>11</b>
Suitable cooking vessels	11
Precautions for use	11
<b>Cleaning and maintenance</b>	<b>12</b>
Cleaning the appliance	12
Burnt-on dirt	12
Burner discolouration	12
<b>Trouble shooting</b>	<b>13</b>
Demo mode	14
<b>After-sales service</b>	<b>15</b>
E number and FD number	15

Additional information on products, accessories, replacement parts and services can be found at [www.gaggenau.com](http://www.gaggenau.com) and in the online shop [www.gaggenau.com/zz/store](http://www.gaggenau.com/zz/store)

## Intended use

Read these instructions carefully. Only then will you be able to operate your appliance safely and correctly. Retain the instruction manual and installation instructions for future use or for subsequent owners.

This appliance is only intended to be fully fitted in a kitchen. Observe the special installation instructions.

This appliance must be installed according to the installation instructions included.

Check the appliance for damage after unpacking it. Do not connect the appliance if it has been damaged in transport.

Only allow a licensed professional to connect the appliance. Damage caused by incorrect connection is not covered under warranty. Call the after-sales service if you want to convert your appliance to a different type of gas.

This appliance is intended for domestic use and the household environment only. This appliance must only be used to prepare food and drinks and must never be used as a heater. Do not leave the appliance unattended during operation. Only use the appliance indoors.

Do not install this appliance on boats or in vehicles.

This appliance is intended for use up to a maximum height of 2000 metres above sea level.

This appliance is not intended for operation with an external clock timer or a remote control.

Do not use covers. These can cause accidents, for example due to overheating, catching fire or materials shattering.

Only use safety devices or child protection grilles approved by ourselves. Unsuitable safety devices or child protection grilles may result in accidents.

This appliance may be used by children over the age of 8 years old and by persons with reduced physical, sensory or mental capabilities or by persons with a lack of experience or knowledge if they are supervised or are instructed by a person responsible for their safety how to use the appliance safely and have understood the associated hazards.

Children must not play with, on, or around the appliance. Children must not clean the appliance or carry out general maintenance unless they are at least 15 years old and are being supervised.

Keep children below the age of 8 years old at a safe distance from the appliance and power cable.

Close the safety valve on the gas supply line if the cooker will not be used for a prolonged period.

## **⚠ Important safety information**

PLEASE READ THIS MANUAL BEFORE INSTALLING AND USING THIS COOKTOP.

This cooker is approved for use with Natural and Propane gases. Leave instructions with the owner.

Do not modify this appliance.

### **⚠ Warning – WHAT TO DO IF YOU SMELL GAS!**

Escaping gas may cause an explosion.

**If you smell gas or notice any faults in the gas installation:**

- Do not light any appliance.
- Do not touch any electrical switch; do not use any phone in the building.
- Immediately call your gas supplier from a neighbour's phone. Follow the gas supplier's instructions.
- If you cannot reach your gas supplier, call the fire department.

### **⚠ Warning – Risk of asphyxiation!**

The use of a gas cooker leads to a build-up of heat, moisture and products of combustion in the room where the appliance is installed. Ensure that the installation room is well ventilated. The natural ventilation openings must be kept open or a mechanical ventilation device must be provided (e.g. an extractor hood). Intensive and persistent use of the appliance may mean that it is necessary to have additional ventilation (e.g. opening a window), or more effective ventilation (e.g. operating the existing mechanical ventilation device at a higher setting).

### **⚠ Warning – Risk of fire!**

- Hot oil and fat can ignite very quickly. Never leave hot fat or oil unattended. Never use water to put out burning oil or fat. Switch off the hotplate. Extinguish flames carefully using a lid, fire blanket or something similar.
- The hotplates become very hot. Never place combustible items on the hob. Never place objects on the hob.
- The appliance becomes very hot and flammable materials could catch fire. Never store or use flammable objects (e.g. spray cans, cleaning agents) under the appliance or in its immediate vicinity. Never place flammable items on or in the appliance.
- When gas hotplates are in operation without any cookware placed on them, they can build up a lot of heat. The appliance and the extractor hood above it may become damaged or be set on fire. Grease residue in the filter of the extractor hood may ignite. Only operate the gas burners with cookware on them.

- If the burner does not ignite after 15 seconds, switch off the control knob and open the door or window in the room. Wait at least 1 minute before igniting the burner again.

### **⚠ Warning – Risk of burns!**

- The appliance becomes hot during operation. Allow the appliance to cool down before cleaning.
- The hotplates and surrounding area (particularly the hob surround, if fitted) become very hot. Never touch the hot surfaces. Keep children at a safe distance.
- The accessible parts become very hot when in operation. Never touch hot parts. Keep children at a safe distance.
- When the appliance cover is closed, heat will accumulate. Only close the appliance cover when the appliance has cooled down. Never switch the appliance on with the appliance cover closed. Do not rest food on the appliance cover or use it to keep food warm.
- Empty cookware becomes extremely hot when set on a gas hotplate that is in operation. Never heat up empty cookware.
- If the liquefied gas bottle is not upright, liquefied propane/butane can enter the appliance. Intense darting flames may therefore escape from the burners. Components may become damaged and start to leak over time so that gas escapes uncontrollably. Both can cause burns. Always use liquefied gas bottles in an upright position.

### **⚠ Warning – Risk of injury!**

- Incorrect repairs are dangerous. Repairs may only be carried out, and damaged power and gas lines replaced, by an after-sales engineer trained by us. If the appliance is faulty, unplug the mains plug or switch off the fuse in the fuse box. Shut off the gas supply. Contact the after-sales service.
- Faults or damage to the appliance are dangerous. Never switch on a faulty appliance. Unplug the appliance from the mains or switch off the circuit breaker in the fuse box. Shut off the gas supply. Contact the after-sales service.
- Unsuitable pan sizes, damaged or incorrectly positioned pans can cause serious injury. Observe the instructions which accompany the cookware.

### **⚠ Warning – Risk of electric shock and serious injury!**

- The cable insulation on electrical appliances may melt when touching hot parts of the appliance. Never bring electrical appliance cables into contact with hot parts of the appliance.
- Do not use any high-pressure cleaners or steam cleaners, which can result in an electric shock.
- A defective appliance may cause electric shock. Never switch on a defective appliance. Unplug the appliance from the mains or switch off the circuit breaker in the fuse box. Contact the after-sales service.
- Incorrect repairs are dangerous. Repairs may only be carried out by one of our trained after-sales engineers. If the appliance is faulty, unplug the mains plug or switch off the fuse in the fuse box. Contact the after-sales service.

---

## Causes of damage

---

### Caution!

- **Risk of heat damage to adjacent appliances or kitchen units:** If the appliance is in operation for an extended period, heat and moisture will be generated. Additional ventilation is required. Open the window or switch on an extractor hood that discharges the extracted air and moisture outside the building.
- **Risk of damage to the appliance due to the build-up of heat:** Do not heat roasters, frying pans or grill stones using more than one burner at a time.
- **Malfunction:** Always turn the control knob to the "Off" position when the appliance is not being used.

---

## Environmental protection

---

The sections below list a number of energy-saving tips and provide information on disposing of your appliance.

### Saving energy

- Choose a burner of roughly the same size as your pan. Place the cookware in the middle.
- Use small saucepans for small quantities. Using a large saucepan with little in it consumes a lot of energy.
- Always place suitable lids on saucepans. Cooking without a lid consumes significantly more energy. Use a glass lid so that you can see into the pan without having to lift the lid.
- Cook with only a little water. This will save energy and preserve the vitamins and minerals in vegetables.
- Switch to a lower heat setting in good time. This will save energy.

### Environmentally-friendly disposal

Dispose of packaging in an environmentally-friendly manner.



This appliance is labelled in accordance with European Directive 2012/19/EU concerning used electrical and electronic appliances (waste electrical and electronic equipment - WEEE). The guideline determines the framework for the return and recycling of used appliances as applicable throughout the EU.

## Familiarising yourself with your appliance

### Gas hob

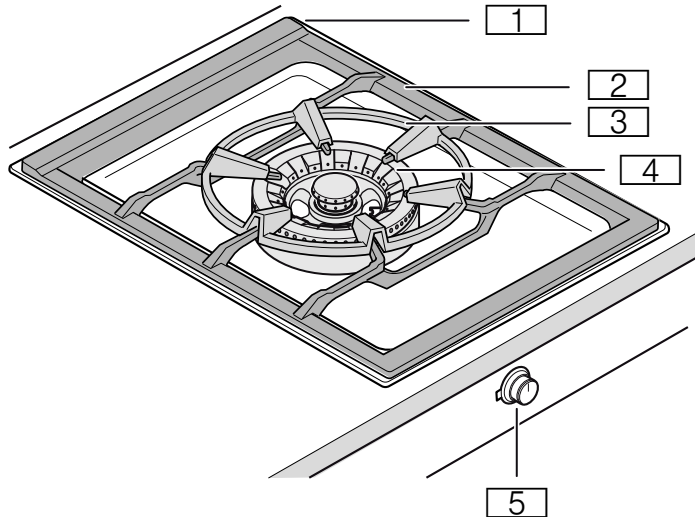

- 1 Ventilation openings (underneath pan support)
- 2 Pan support
- 3 Wok ring
- 4 Wok burner 18 MJ/h (5 kW)
- 5 Wok burner control knob

### Control knob

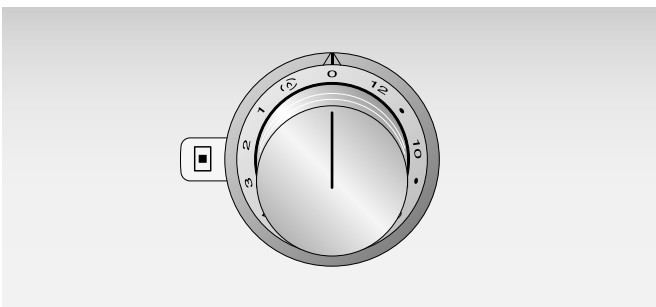

The markings show the setting between level 1 to 12 or simmering (🔥).

### Visual signals of the luminous disc

The control knob is encircled by an illuminated ring that indicates a number of statuses and functions.

Indicator	Meaning
○ Off	Appliance off
● Lit continuously orange	Appliance on
☀ Flashing orange	Appliance off Residual heat indicator
☀ Flashing orange and white alternately	Safety shut-off, power failure
☀ Flashing yellow and magenta alternately	Appliance fault Call the after-sales service.
● Lit green and then yellow for some seconds	Appliance initialising, only after first installation or power failure

### Special accessories

You can order the following special accessories from your specialist dealer:

- WP 400 001 Multi-layer material wok pan, with curved base and handle, Ø 36 cm, 6 litres volume, 10 cm high.

Only use the accessories as specified. The manufacturer accepts no liability if these accessories are used incorrectly.

## Individual parts of the wok burner

Ensure that the individual parts of the wok burner are fitted in the correct position and are straight; otherwise, this may result in ignition problems or problems during operation. Fit the burner head such that the thermocouple is positioned in the corresponding recess on the burner head. The lug on the burner ring must engage in the corresponding recess on the burner head.

**Note:** If the burner parts are fitted at an angle, the appliance will not work.

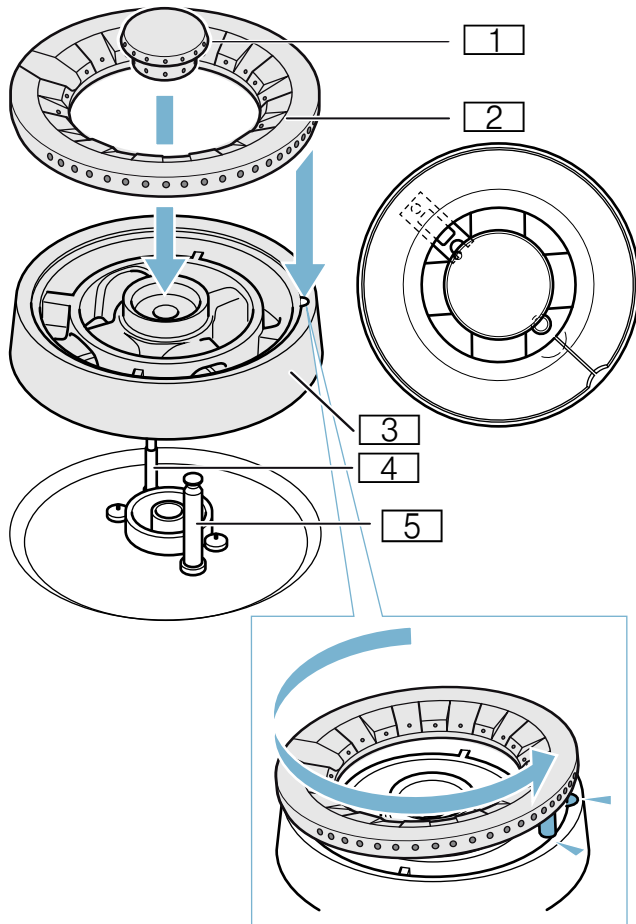

- 1 Burner cap
- 2 Burner ring
- 3 Burner head
- 4 Thermocouple
- 5 Ignition plug

## Operating the appliance

### Notes

- Only use the accessories specified. Do not line the stainless steel recess (e.g. with aluminium foil).
- The burner and ignition plug must be clean and dry.
- Only light the hotplates if the pan supports and all burner parts are correctly fitted.
- Do not touch the ignition plug while the gas appliance is being lit.
- It is important to keep the appliance clean. If the ignition plugs are dirty, this may cause ignition problems. Clean the ignition plugs regularly with a small, non-metallic brush. Take care to prevent the ignition plugs from suffering any heavy knocks.
- When you cook using a wok, place the wok ring onto the pan support over the wok burner. Make sure that the wok is stable on the wok ring when you are cooking.
- When you switch from setting 3 to setting 4 or higher, the burner will briefly switch to its maximum output. This is to optimise ignition between the burner rings.
- Do not cover the ventilation openings on the rear of the gas hob.
- When the gas cooktop is switched on, the electronics open up the gas supply, which produces a short sound. This is normal.
- In the event of a power failure, the appliance will not work. The gas supply is shut off.

### Abnormal operation

Flames are usually blue and sharply defined. If the flames are yellowish or noisy or if the gas does not ignite within the period specified under "switching on" abnormal operation is indicated. Refer to chapter "After-sales service" of this manual for service contact details.



## Switching on

Your gas hob has an automatic quick-ignition function.

- 1 Place a suitable item of cookware on the pan support.
- 2 Push in the control knob and turn it clockwise or anti-clockwise to the heat setting you require.

The burner ignites automatically.

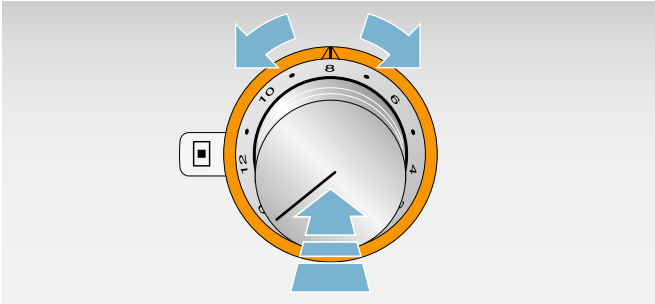

Turn the control knob to set the heat setting.

### **⚠ Warning – Risk of deflagration!**

If the burner does not ignite after 15 seconds, switch off the control knob and open the door or window in the room. Wait at least 1 minute before igniting the burner again.

## Simmer setting

With the simmer setting, the burner switches the gas flame on and off. This allows you to melt chocolate or heat up delicate sauces, for example.

Turn the control knob to (D). It takes 10 - 50 seconds to switch on or off.

## Electronic flame monitoring and automatic re-ignition

For your safety, the hob has an electronic flame monitoring system. If the flame goes out while the hob is in use (e.g. due to a draught), the appliance will automatically re-ignite the burner.

If re-ignition is unsuccessful (e.g. because liquid or food has boiled over and remains on the burner), the appliance will switch off the gas supply. The illuminated ring behind the control knob will flash.

Turn the control knob to 0. Wait until the appliance is cool enough and then check whether all the burner parts are in the correct position. Check whether the burner or the ignition plug are covered in food remnants etc. → "Trouble shooting" on page 13

## Switching off

Turn the control knob to position 0. The appliance electronics will shut off the gas supply.

### **⚠ Warning – Risk of burns!**

When the appliance cover is closed, heat will accumulate. Only close the appliance cover when the appliance has cooled down. Never switch the appliance on with the appliance cover closed. Do not rest food on the appliance cover or use it to keep food warm.

## Residual heat indicator

The luminous disc behind the control knob flashes after switching off, to indicate that the appliance has still not cooled down to such an extent that it can be touched safely.

## Safety shut-off

For your safety, the appliance has a safety shut-off function. The appliance is automatically switched off if it has been in operation for an extended period. How long the appliance waits before switching itself off depends on the setting (setting 12 = 1 hour, setting 1 = 4 hours). The illuminated ring behind the control knob will flash orange and white alternately.

Turn the control knob to 0. You will now be able to start the appliance again as usual.

## Table of settings and tips

Heat setting	Cooking method	Examples
12	Heating	Water, clear soups
	Blanching	Vegetables
10-12	Searing	Meat, wok dishes/pan-fried dishes
	Frying at high temperatures	Meat, potatoes
7-10	Simmering with the lid open	Liquids, dough-based foods
6-8	Baking	Flour-based food
	Frying at medium temperatures	Poultry, fish
4-6	Frying at low temperatures	Fried sausages, onions, egg dishes
	Warming	Vegetables, soups, stews
	Deep-frying	Chips, pastries
	Poaching with the lid open	Dumplings, boiled sausages
3-4	Defrosting	Frozen food
	Braising	Beef olives, joints
	Stewing	Vegetables
2-4	Simmering with the lid on	Soups, vegetables
Simmer setting – up to 3	Soaking	Rice, rice pudding, cereals
Simmer setting	Melting, keeping warm	Chocolate, butter

## Tips for cooking and roasting

The values given in the settings table must be looked upon as recommended values. The heat required depends not only on the type and condition of the food, but also the size and contents of the pot.

Due to the high performance of the cooktop, fat and oil will heat up quickly. Never leave the cooktop unattended, fat can ignite, food can burn.

## Tips for using a wok

**Note:** When you cook using a wok, place the wok ring onto the pan support over the wok burner. Make sure that the wok is stable on the wok ring when you are cooking.

We recommend using woks with a domed base. You can order a high-quality wok as an optional accessory (WP 400 001).

When cooking with the wok, use only cooking oil that is suitable for heating to high temperatures, such as groundnut oil.

Cook the ingredients at a high heat, while stirring constantly. Do not cook them for too long. The vegetables should be al dente.

For stirring the food and for taking it out of the pan, it is best to use a shallow ladle with a long handle made from a heat-resistant material.

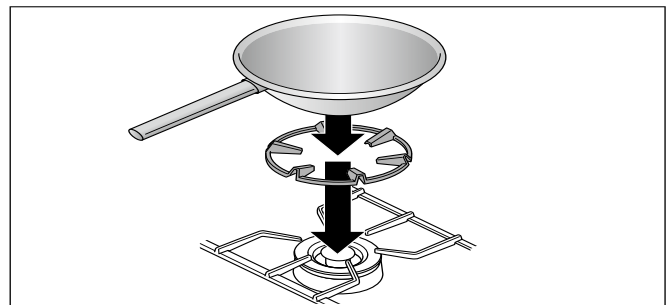

## Information and tips regarding cookware

The following information and tips have been provided to help you save energy and avoid damaging your cookware.

### Suitable cooking vessels

Burner	Recommended pan base diameter	Minimum pan base diameter
Wok burner	240 - 320 mm	160 mm
	Use the wok only on the wok ring.	

Pans with a diameter of less than 160 mm or more than 320 mm should not be used. If you do use larger pans, these should not protrude beyond the edges of the appliance.

## Precautions for use

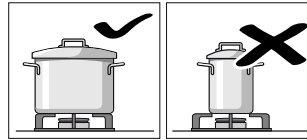

Use pots or pans which are the right size for each burner.

Do not use small pots or pans on large burners. The flame should not touch the sides of the pot.

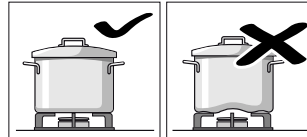

Do not use damaged pots or pans, which do not sit evenly on the cooktop, they may tip over.

Only use pots or pans with a thick, flat base.

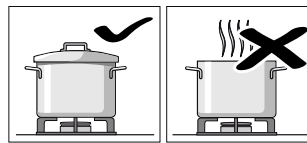

Do not cook without using a lid and make sure the lid is properly fitted. This wastes energy.

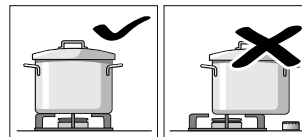

Always centre the pot or pan over the burner, otherwise it could tip over.

Do not place large pots on the burners near the control knobs. These may get damaged by the high temperatures.

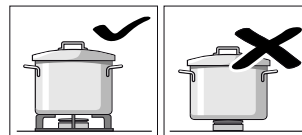

Place the pots or pans on the pan support, never directly on the burner.

Make sure that the pan supports and burner caps are correctly positioned before using the appliance.

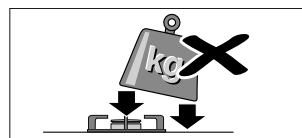

Pots or pans should be placed on the cooktop carefully.

Do not strike the cooktop and do not place excessive weight on it.

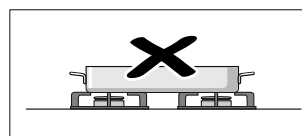

Do not heat a cooking vessel (e.g. roaster, pan, grill stone) on more than one burner at the same time. The resulting heat accumulation will damage the appliance.

## Cleaning and maintenance

### **⚠ Warning – Risk of electric shock!**

Do not use any high-pressure cleaners or steam cleaners, which can result in an electric shock.

### **⚠ Warning – Risk of burns!**

The accessible parts become very hot when in operation. Never touch hot parts. Keep children at a safe distance.

### **Caution!**

#### **Risk of surface damage**

Do not use these cleaners

- harsh or abrasive cleaning agents
- oven cleaners
- corrosive or aggressive cleaners, or those containing chlorine
- cleaning agents with a high alcohol content
- hard and scratchy sponges, brushes or scouring pads

If such an agent comes into contact with the appliance, wash it off immediately with water.

Thoroughly wash out new sponge cloths before using them!

## Cleaning the appliance

Clean the appliance after each use once it has cooled down. Remove spilt liquids immediately and do not allow any food remains to burn on.

Make sure that the ventilation openings under the pan support are always clean. The ventilation openings must not be covered.

Dry the burners thoroughly after cleaning. Only operate the appliance when the burners are dry. Damp burners can cause ignition problems and/or an unstable flame.

During assembly, make sure that the burner parts (catch tappets) are in the correct position. All parts must be straight.

Appliance part/ surface	Recommended cleaning
Stainless steel surfaces	Use soapy water and dry with a soft cloth. Only use a minimal amount of water when cleaning so that no water enters the appliance.  Soak burnt-on remains with a small amount of soapy water; do not scour.  Remove heavy soiling or yellow discolouration caused by heat using our stainless steel cleaning agent (item no. 00311499).
Pan supports, wok ring	Carefully remove them for cleaning. Soak in the sink. Clean using a scrubbing brush and detergent.  Clean the area around the rubber buffers carefully so that they do not become detached.  Rinse with clean water before leaving to dry.  <b>Do not clean them in the dishwasher.</b>
Burner parts	Use soapy water and dry with a soft cloth. Make sure that the openings are not blocked.  Take care that no small parts are lost.  <b>Do not clean them in the dishwasher.</b>
Control knob	The soapy cloth must not be too wet. Dry with a soft cloth.

## Burnt-on dirt

For hard-to-remove, burnt-on dirt, you can order a cleaning gel from our online shop, from your specialist retailer or our after-sales service (item number 00311859). It is suitable for pan supports and the stainless-steel recess. If necessary, let the dirt soak overnight. Follow the instructions on the cleaning agent.

### **Caution!**

#### **Damage to the surface**

Do not use the cleaning gel on the burner parts.

## Burner discolouration

After extended use, the brass burner parts take on a darker colour as a result of the oxidation process that occurs naturally. The discolouration does not affect their serviceability.

## Trouble shooting

Malfunctions often have simple explanations. Please read the following notes before calling the after-sales service.

### Warning – Risk of electric shock!

Incorrect repairs are dangerous. Repairs may only be carried out by one of our trained after-sales engineers. If the appliance is faulty, unplug the mains plug or switch off the fuse in the fuse box. Contact the after-sales service.

Disruption	Possible cause	Solution
The burner will not ignite when it is switched on.	Power supply disconnected.	Turn all control knobs to 0. Check the fuse box to see whether the circuit breaker has tripped.
The burner will not ignite when it is switched on.  The illuminated ring behind the control knob is flashing orange and white alternately.	Burner or gas supply fault.	Turn all control knobs to 0.  <b>Check:</b> <ul style="list-style-type: none"> <li>● Are the burner parts positioned correctly?</li> <li>● Is the main gas tap open?</li> <li>● Is the burner clean and dry?</li> <li>● Is there air in the line following initial connection or a cylinder change (in the case of liquid gas)?</li> <li>● Is the gas cylinder empty (in the case of liquid gas)?</li> </ul>
The burner will not ignite when it is switched on.  All the illuminated rings behind the control knobs are lit white for 10 seconds after switch-on. Then the illuminated ring around the active control knob is lit orange.	Demo mode is activated.	Deactivate demo mode.
The burner will not ignite when it is switched on.  The illuminated ring behind the control knob is flashing yellow and magenta alternately.	Electronics fault	Turn all control knobs to 0 and disconnect the appliance from the mains power supply for one minute (switch off the circuit breaker or pull out the plug).  Reconnect the appliance. The illuminated rings around the control knobs will be lit green for a few seconds and then turn yellow. Wait until the illuminated rings switch off. Then turn any of the control knobs to any of the heat settings and then back to 0.  Switch on the burner. If the illuminated ring starts flashing yellow and magenta again, call our after-sales service.
The burner goes out while the appliance is in operation.  The illuminated ring behind the control knob is flashing orange and white alternately.	Safety switch-off function: No actions have been performed for an extended period.	Turn all control knobs to 0, and then switch them back on if you wish to continue using the appliance.
The burner goes out while the appliance is in operation.  The illuminated ring behind the control knob is flashing orange and white alternately.	Domestic power failure: Following a power failure, the appliance will remain switched off for safety reasons.	Turn all control knobs to 0, and then switch them back on if you wish to continue using the appliance.
There is a smell of gas in the kitchen.	Gas may be leaking out where the gas cylinder is connected.	Check that the gas cylinder connection is not leaking. Open windows and ensure the room is well ventilated.

The appliance panelling becomes slightly raised at the corners when it is in operation.	The metal from which the cooktop is made expands as it heats up.	This is normal. It will contract again once it has cooled down.
---	--	---

### Notes

- Each time the mains power is switched on or following a power failure, a sound is produced when the gas valves are started up. The illuminated rings around the control knobs will be lit green for a few seconds and then turn yellow. Wait until the illuminated rings switch off.
- When the gas cooktop is switched on, the electronics open up the gas supply, which produces a short sound. A sound can also be heard when the setting is changed. This is normal.

### Demo mode

The demo mode is activated if all of the illuminated rings around the control knobs light up white for 10 seconds after switching on the appliance. The burner does not ignite. The illuminated ring around the active control knob lights up orange.

#### You can deactivate the demo mode as follows:

- 1 Turn all of the control knobs to 0. Disconnect the appliance from the mains power supply. Wait at least 30 seconds.
- 2 Reconnect the appliance. The illuminated rings around the control knobs light up green for a few seconds and then turn yellow. Wait until the illuminated rings switch off.
- 3 Then deactivate demo mode within three minutes as follows:  
Turn any of the control knobs anti-clockwise to position 12.
- 4 Turn the control knob clockwise to position 1.
- 5 Turn the control knob anti-clockwise to position 0. Wait until the illuminated ring lights up yellow.
- 6 Turn the control knob clockwise to position 1. The illuminated ring lights up green.  
Wait for five seconds. The illuminated ring now turns yellow.

Demo mode has now been deactivated. **To save the setting, always exit the menu as follows:**

- 7 Turn the control knob to 0. Then turn the control knob anti-clockwise to position 12. Turn the control knob clockwise to position 1. Turn the control knob anti-clockwise to position 0. Wait until the illuminated ring goes out.

---

## After-sales service

---

Our after-sales service is there for you if your appliance needs to be repaired. We will always find an appropriate solution, also in order to avoid after-sales personnel having to make unnecessary visits.

### E number and FD number

When calling us, please quote the full product number (E no.) and the production number (FD no.) so that we can provide you with the correct advice. The rating plate that features these numbers can be found on the underside of the appliance.

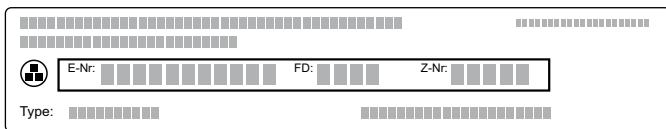

To save time, you can make a note of the numbers for your appliance and the telephone number of the after-sales service in the space below in case you need them.

---

**E no.**

**FD no.**

---



---

### After-sales service

---

Please note that a visit from an after-sales service engineer is not free of charge in the event that the appliance has been misused, even during the warranty period.

Please find the contact data of all countries in the enclosed customer service list.

#### To book an engineer visit and product advice

**GB** 0344 892 8988

Calls charged at local or mobile rate.

**IE** 01450 2655

0.03 € per minute at peak.

Off peak 0.0088 € per minute.

**AU** 1300 368 339

**NZ** 09 477 0492

Trust the expertise of the manufacturer, and rest assured that the repair will be carried out by trained service technicians using original spare parts for your domestic appliance.

**Gaggenau Hausgeräte GmbH**  
Carl-Wery-Straße 34  
81739 München  
GERMANY  
[www.gaggenau.com](http://www.gaggenau.com)

9001154461 (970701)  
en

**GAGGENAU**

