

GAGGENAU

The models and dimensions





The definitive guide to the definitive kitchen

The world of Gaggenau is within your hands.

Our products perform exceptionally, are technologically advanced, built without compromise and designed to be appreciated by both the hand and the eye.

This comprehensive handbook will enable the smooth, we would not say effortless, creation of the kitchen for your client. It is all here, clearly and cleanly presented, easy to find and utterly complete. See for yourself.

The difference is Gaggenau.

The oven EB 333	2		EB 333
The ovens 400 series	8		Ovens 400 series
The ovens 200 series	52		Ovens 200 series
The Vario cooktops	90		Vario cooktops
The cooktops	156		Cooktops
The extractors	226		Extractors
The cooling appliances	304		Cooling appliances
The dishwashers washing machine tumble dryer	376		Dishwashers Washing machine
Energy Label Home Connect The accessories	408		Energy Label Home Connect Accessories



The oven EB 333

EB 333

Accessories | special accessories EB 333

Technical specifications EB 333

4
5
6



EB 333 111
Stainless steel
Width 90 cm



Included in the price

- 1 baking tray, enamelled pyrolysis-safe
- 1 rotisserie spit
- 1 wire rack
- 1 grill tray with wire rack
- 1 plug-in core temperature probe

Special accessories

- BA 018 105**
Pull-out system
Fully extendable telescopic rails and enamelled cast iron frame.
- BA 028 115**
Baking tray, enamelled
30 mm deep.
- BA 038 105**
Wire rack, chromium-plated
Without opening, with feet.
- BA 058 115**
Heating element for baking stone and Gastronorm roaster.
- BA 058 133**
Baking stone.
Incl. baking stone support and pizza paddle (heating element must be ordered separately).
Not in combination with pull-out system.
- BA 090 100**
Black rotary knobs for EB 333, set of 2
Stainless steel knobs with black coating.
- BS 020 002**
Pizza paddle, set of 2.
- GN 340 230**
Gastronorm roaster in cast aluminium.
GN 2/3, height 165 mm, non-stick.

Oven EB 333

- One-piece front-hinged door with 3 mm precision crafted stainless steel front door panel
- Cushioned door opening and closing system
- Diagonally positioned light sources for optimal interior lighting
- Pyrolytic system
- 17 heating methods with core temperature probe, rotisserie spit and baking stone function
- Automatic programmes
- Core temperature probe with estimation of cooking time
- Hot air fan rotates in both directions for ideal heat distribution
- TFT touch display
- Panel-free appliance with control module behind glass
- Electronic temperature control from 30 °C to 300 °C
- Net volume 83 litres

Heating methods

- Hot air.
- Eco hot air.
- Top + bottom heat.
- Top + 1/3 bottom heat.
- Top heat.
- 1/3 top + bottom heat.
- Bottom heat.
- Hot air + bottom heat.
- Hot air + 1/3 bottom heat.
- Full surface grill + circulated air.
- Full surface grill.
- Compact grill.
- Baking stone function.
- Roaster function.
- Dough proofing.
- Defrosting.
- Keeping warm.

Handling

- Rotary knob and TFT touch display operation.
- Clear text display.
- Option to save individual recipes (incl. core temperature probe).
- Personalisation of automatic programmes.
- Information key with use indicators.
- Front-hinged door with 90° door opening angle.

Features

- Three-point core temperature probe with automatic shut-off and estimation of cooking time.
- Automatic programmes.
- Rotisserie spit.
- Baking stone socket.
- Actual temperature display.
- Rapid heating.
- Timer functions: cooking time, cooking time end, timer, stopwatch, long-term timer (certified by Star-K).
- 60 W halogen light on the top.
- 2 x 10 W halogen light on the side.
- Enamelled side shelf supports with 3 tray levels, pyrolysis-safe.

Selected digital services (Home Connect)

- Automatic programmes.
- Remote control and monitoring.
- Recipes.

Please read additional information on Home Connect on page 411.

Safety

- Thermally insulated door with quintuple glazing.
- Child lock.
- Safety shut-off.
- Cooled housing with temperature protection.

Cleaning

- Pyrolytic system.
- Gaggenau enamel.
- Heated catalyser to clean the oven air.

Planning notes

- The door panel surface of the appliance extends 40 mm from the furniture cavity.
- The outer edge of the door handle extends 90 mm from the furniture cavity.
- For installation underneath cooktops: Distance between the underside of the cooktop and the top edge of the oven cavity: min. 15 mm. The planning notes for the cooktops (particularly regarding ventilation, gas/electric connection) must be taken into account.
- To achieve the 550 mm installation depth, the connection cable needs to follow the slanted edge on the corner of the housing.
- The mains socket needs to be planned outside the built-in niche.
- The LAN port can be found at the back on the upper left side.

Connection

- Energy efficiency class A at a range of energy efficiency classes from A+++ to D.
- Total connected load 5.4 kW.
- Plan a connection cable.
- Plan a LAN cable.

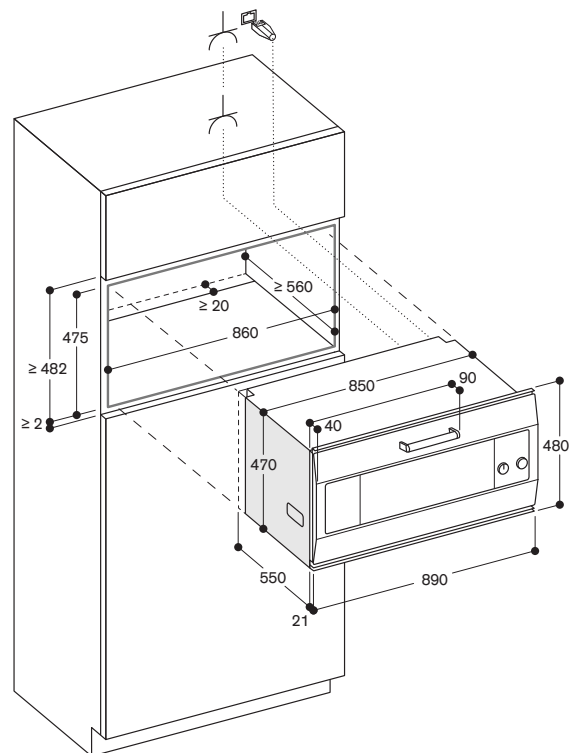
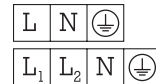

Socket

measurements in mm

*Energy efficiency class: at a range of energy efficiency classes from A+++ to D.

Advice: Not every illustrated accessory fits to every oven. For exact allocation see page 6.

BA 090 100
Stainless steel knobs with black coating.



BA 018 105
Pull-out system
Fully extendable telescopic rails and enamelled cast iron frame.



BA 028 115
Baking tray, enamelled
30 mm deep.



BA 038 105
Wire rack, chromium-plated
Without opening, with feet.



BA 058 115
Heating element for baking stone and
Gastronorm roaster

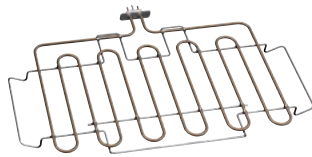

BA 058 133
Baking stone
Incl. baking stone support and pizza
paddle (heating element must be
ordered separately). Not in combina-
tion with pull-out system.



BS 020 002
Pizza paddle, set of 2.



GN 340 230
Gastronorm roaster in cast aluminium
GN 2/3, height 165 mm, non-stick
For roasting in oven with roasting
function.
Lower and upper part can also be
used separately, height 100 and
65 mm.
For ovens with heating element
BA 056 115 or BA 058 115 and
pull-out system BA 016 or BA 018
(both to be ordered separately) and
Combi-steam and steam ovens.



Accessories and special accessories EB 333



EB 333

Black rotary knobs for oven			Oven
BA 090 100	Stainless steel knobs with black coating		◦
Baking tray, enamelled			
BA 028 115	30 mm deep		•/◦
Pull-out rack			
BA 018 105	Pull-out system with fully extendable telescopic pull-out rack and pyrolysis-safe cast frame		◦
Baking stone			
BA 058 133	incl. baking stone support and pizza paddle (heating element must be ordered separately)		◦
Gastronorm roaster, cast aluminium			
GN 340 230	GN 2/3, height 165 mm, non-stick		◦
	For ovens with heating element BA 056 115 or BA 058 115 and pull-out system BA 016 or BA 018 (both to be ordered separately) and for Combi-steam ovens with adapter GN 010 330 and pull-out system BA 010 301 (See also page 412)		
Wire rack, chromium-plated			
BA 038 105	no opening, with feet		•/◦
Part No. 706321	for grill tray ET-Nr. 687055, with opening and feet		•/◦
Grill tray, enamelled			
Part No. 687055	with feet and rotisserie spit attachment, 30 mm deep		•/◦
Heating element			
BA 058 115	Necessary accessory for baking stone BA 058 133		◦
Pizza paddle			
BS 020 002	Set of 2		◦

• Standard.

◦ Special accessory.



Appliance type	Oven	
Stainless steel	EB 333	
Dimensions		
Width	(cm)	90
Appliance dimensions W x H x D ¹	(mm)	890 x 480 x 550
Door panel extension from furniture cavity	(mm)	21
Niche dimensions W x H x D	(mm)	860 x 475 x 560
Net weight	(kg)	79
Volume / energy efficiency (to EU regulations EN 60350-1, 65/2014 and 66/2014)		
Net volume	(l)	83
Number of cooking compartments		1
Interior dimensions W x H x D	(mm)	624 x 315 x 403
Energy efficiency class with eco hot air		A *
Energy Efficiency Index (EEI)		95.6
Energy consumption with top / bottom heat	(kWh)	1.32
Energy consumption with eco hot air	(kWh)	0.86
Heat source		electric
Heating methods		
Temperature range	(°C)	30–300
Hot air / Eco hot air / top + bottom heat		• / • / •
Top heat / bottom heat / hot air + bottom heat		• / • / •
Top + 1/3 bottom heat		•
1/3 top + bottom heat		•
Hot air + 1/3 bottom heat		•
Full surface grill + circulated air		•
Full surface grill		•
Compact grill		•
Baking stone function		•
Roaster function		•
Dough proofing / defrosting / keeping warm		• / • / •
Handling		
TFT touch display		•
Controls at the top / centered / at the bottom		• / - / -
Automatic door opening		-
Clear text display	(No. of languages)	44
Individual recipes		50
Door opening angle	(°)	90
Features		
Electronic temperature control		•
Three-Point core temperature probe		•
Automatic programmes		•
Rotisserie spit		•
Baking stone socket		•
Roasting function		•
Actual temperature display		•
Rapid heating		•
Cooking time, cooking time end, timer, stopwatch		•
Long-term timer		•
Halogen light on the top	(W)	60
Halogen light on the side	(W)	2 x 10
Tray levels	(No.)	3
Digital services (Home Connect) either via LAN or wireless via WiFi. ³		• ³
Accessories		
Enamelled baking tray		1
Size of largest baking tray	(cm ²)	1.780
Wire rack		1
Enamelled grill tray / wire rack for grill tray		1/1
Glass tray		-
Safety		
Thermally insulated door with multiple glazing		5-fold
Child lock / door lock / safety shut-off		• / • / •
Cooled housing with temperature protection		•
Cleaning		
Pyrolytic system		•
Gagggenau enamel		•
Heated air cleaning catalyser		•
Connection		
Total connected load	(kW)	5.38

• Standard. – Not available.

¹ Appliance depth: the immersion depth of the appliance in the niche. ² Special accessory, see page 5–6.

³ The use of the Home Connect functionality depends on the Home Connect services, which are not available in every country.

* Energy efficiency class: at a range of energy efficiency classes from A+++ to D.



The ovens 400 series

Checklist for appliance combinations 400 series	10
Planning notes for ovens and oven combinations	14
Ovens 400 series	16
Combi-steam ovens 400 series	22
Combi-microwave ovens 400 series	28
Fully automatic espresso machine 400 series	30
Vacuuming drawers 400 series	32
Warming drawers 400 series	34
Accessories special accessories 400 series	38
Technical specifications 400 series	44

Checklist for appliance combinations 400 series

This checklist provides the most relevant parameters for the perfect combination and ordering of ovens, Combi-steam ovens, Combi-microwave ovens, fully automatic espresso machine, vacuuming drawers, warming drawers and dishwashers.

In general:

- All appliances shown can be obtained with stainless-steel-backed full glass doors.
- When several appliances are listed (BS/BM and DV/WS), the first appliance is shown.

Vertical combinations

When planning and ordering please note that

- The door hinges of the appliances must be on the same side.
- The door hinge (right-/left-hinged) is not reversible.
- The width of the appliances is identical.
- The control modules of the two appliances should meet each other in the middle of the combination.
- No further appliances may be fitted above the BS.
- Only appliances with controls at the top can be installed above a dishwasher. The niche for appliances that are installed above it must be 56 cm wide. The dishwasher is 60 cm wide. A stainless-steel-backed full glass door can be obtained as a special accessory.

Horizontal combinations

When planning and ordering please note that

- The door hinges need to be placed on the outside in order to use the full available door opening angle.
- The door hinge (right-/left-hinged) is not reversible.
- A minimum clearance of 10 mm between the two doors must be observed.
- Combi-steam ovens, Combi-microwave ovens and fully automatic espresso machine in combination with a vacuuming drawer or a warming drawer (14 cm in height) have the same total height as a 60 cm wide oven.
- The control modules are either all at the top or all at the bottom.

BO Ovens
 BS Combi-steam ovens
 BM Combi-microwave ovens
 CM Fully automatic espresso machine
 DV Vacuuming drawers
 WS Warming drawers
 DF Dishwashers

Vertical combination, 76 cm / 30" wide appliances



- BS 484/BM 484
- BO 480
- WS 482

- BX 480
- WS 482

Combination of 4, 76 cm / 30" wide appliances



- BS 485/BM 485
- BO 481

- BS 484/BM 484
- BO 480

Horizontal combination, 76 cm / 30" wide appliances



- BO 481

- BO 480

Vertical combination, 60 cm wide appliances



- BS 474/BS 454/BM 454
- BO 470/BO 450/BO 420
- WS 462

- BS 454/BS 474/BM 454
- BO 470/BO 450/BO 420
- WS 462

- BS 454/BS 474/BM 454
- BM 450
- DV 461/WS 461

- BM 454/BS 474/BS 454
- CM 450
- WS 461/DV 461



- BO 470/BS 450/BO 420
- DF

- BS 470/BS 450/BM 450
- DF

- CM 450
- DF

Horizontal combination, 60 cm wide appliances



▪ BO 471/BO 451/BO 421 ▪ BO 470/BO 450/BO 420



▪ BO 471/BO 451/BO 421 ▪ BS 470/BS 450/BM 450
▪ DV 461/WS 461



▪ BO 471/BO 451/BO 421 ▪ CM 450
▪ WS 461/DV 461



▪ BS 451/BS 471/BM 451 ▪ BM 450/BS 470/BS 450
▪ WS 461/DV 461 ▪ DV 461/WS 461



▪ BS 471/BS 451/BM 451 ▪ CM 450
▪ DV 461/WS 461 ▪ WS 461/DV 461



▪ BO 471/BO 451/BO 421 ▪ CM 450 ▪ BS 470/BS 450/BM 450
▪ WS 461/DV 461 ▪ DV 461/WS 461



▪ BM 451/BS 471/BS 451 ▪ CM 450 ▪ BS 450/BS 470/BM 450
▪ WS 461/DV 461 ▪ DV 461/WS 461 ▪ WS 461/DV 461

Combination of 4 with warming drawer, 60 cm wide appliances



▪ BS 455/BS 475/BM 455 ▪ BM 454/BS 474/BS 454
▪ BO 471/BO 451/BO 421 ▪ CM 450
▪ DV 461/WS 461

Checklist for appliance combinations 400 series

Vertical combination, 60 cm / 30" wide appliances

This checklist provides the most relevant parameters for the perfect combination and ordering of ovens, Combi-steam ovens, Combi-microwave ovens, fully automatic espresso machine, vacuuming drawers, warming drawers and dishwashers.

In general:

- All appliances shown can be obtained with full glass doors in Gaggenau Anthracite.
- When several appliances are listed (BS/BM), the first appliance is shown.

Vertical combinations

When planning and ordering please note that

- The door hinges of the appliances must be on the same side.
- The door hinge (right-/left-hinged) is not reversible.
- The width of the appliances is identical.
- The control modules of the two appliances should meet each other in the middle of the combination.
- No further appliances may be fitted above the BS.
- Only appliances with controls at the top can be installed above a dishwasher. The niche for appliances that are installed above it must be 56 cm wide. The dishwasher is 60 cm wide.



- BS 474/BS 454/BM 454
- BO 470/BO 420
- WS 462



- BM 454/BS 474
- BO 470/BO 420
- WS 462



- BS 474/BS 454/BM 454
- BM 450
- DV 461/WS 461



- BM 454/BS 474
- CM 450
- WS 461/DV 461



- BO 470/BO 420
- DF



- BS 470/BM 450
- DF



- CM 450
- DF

Horizontal combinations

When planning and ordering please note that

- The door hinges need to be placed on the outside in order to use the full available door opening angle.
- The door hinge (right-/left-hinged) is not reversible.
- A minimum clearance of 10 mm between the two doors must be observed.
- Combi-steam ovens, Combi-microwave ovens and fully automatic espresso machine in combination with a vacuuming drawer or a warming drawer (14 cm in height) have the same total height as a 60 cm wide oven.
- The control modules are either all at the top or all at the bottom.

- BO Ovens
- BS Combi-steam ovens
- BM Combi-microwave ovens
- CM Fully automatic espresso machine
- DV Vacuuming drawers
- WS Warming drawers
- DF Dishwashers

Horizontal combination, 60 cm wide appliances



▪ BO 471/BO 421 ▪ BO 470/BO 420



▪ BO 471/BO 421 ▪ BS 470/BM 450
▪ DV 461/WS 461



▪ BO 471/BO 421 ▪ CM 450
▪ WS 461/DV 461



▪ BS 471/BM 451 ▪ BM 450/BS 470
▪ DV 461/WS 461 ▪ WS 461/DV 461



▪ BS 471/BM 451 ▪ CM 450
▪ DV 461/WS 461 ▪ WS 461/DV 461



▪ BO 471/BO 421 ▪ CM 450 ▪ BS 470/BM 450
▪ WS 461/DV 461 ▪ DV 461/WS 461



▪ BM 451/BS 471 ▪ CM 450 ▪ BS 470/BM 450
▪ WS 461/DV 461 ▪ WS 461/DV 461 ▪ DV 461/WS 461

Combination of 4 with warming drawer, 60 cm wide appliances



▪ BS 475/BM 455 ▪ BM 454/BS 474
▪ BO 471/BO 421 ▪ CM 450
▪ DV 461/WS 461

Planning notes for the installation of ovens and oven combinations 400 and 200 series

General notes

Installation behind kitchen furniture doors

Appliance in operation only with open doors. Appropriate measures must be taken to prevent these types of doors from closing when the appliance is heating or while it is cooling down (fan operation).

Installation side by side

When appliances are installed side by side, the clearance between the appliances must be at least 10 mm (corresponds to the standard outside measurement of the furniture cavity of 600 or 762 mm). The door hinges need to be placed outside in order to use the full available door opening angle.

Combination of ovens and Vario cooling 400 series appliances

Please check the planning notes in the information for Vario cooling 400 series appliances in order to prevent the refrigerator door from colliding with the oven.

Necessary air cross section at the door edges

Gaggenau ovens are cooled with fresh air at the top edge and side edges of the door. Hot air is blown out at the door bottom edge. Combi-steam ovens and Combi-microwave ovens have the air inlet at the side edges of the door and the hot air and steam outlets at the top edge of the door. In order to prevent appliances from overheating and to ensure that they cool down as required after operation, appropriate minimum cross sections of free space must be maintained from kitchen furniture edges.

The measurements given in the drawing apply to all appliances. The following must also be observed:

The area above the appliances

BS:

No other electrical appliances should be installed above the BS. It is recommended that a horizontal handle is not fitted on furniture above the BS.

Where the edge of a kitchen unit protrudes more than 20 mm from the front edge of the furniture cavity, the edge of the kitchen furniture panel must be steam resistant as is the case above a dishwasher. Steam may possibly penetrate into the compartment.

The area below the appliances

DV / WS:

It must be ensured that there is sufficient access to the lower edge of the vacuuming drawer and warming drawer, if the thickness of the kitchen furniture door is greater than 20 mm in front of the furniture cavity.

When installed next to each other

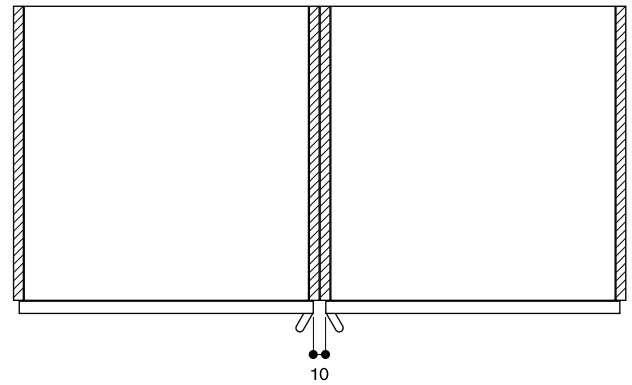

Cross section of the top/bottom door edge gaps

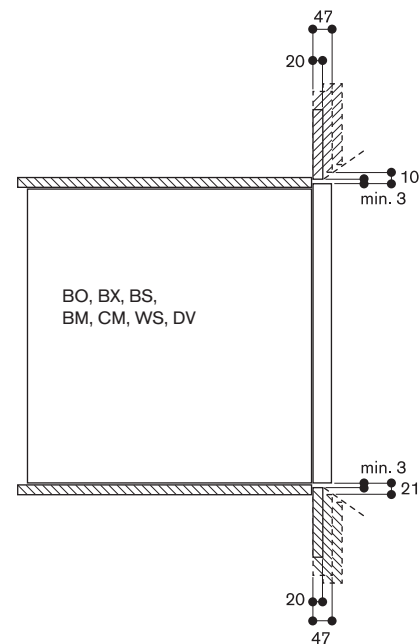

At the sides

In cases where kitchen furniture door thicknesses are greater or where sidewalls protrude up to 34 mm from front of the edge of the furniture cavity, the minimum distance on the hinge side is sufficient for the air supply and a door opening angle of 120°. Above that, a distance of 10 mm or even more is required.

The handle side may, if required, be covered by a side panel provided that the minimum distance is maintained.

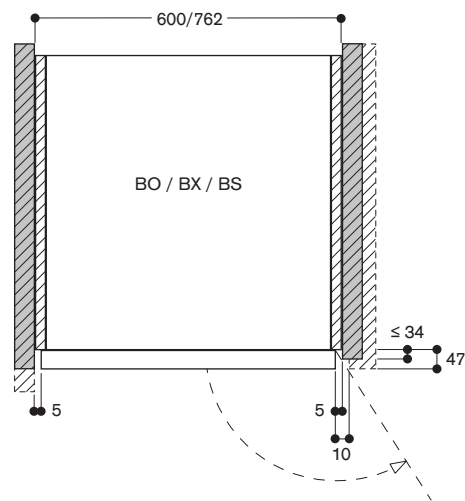
Air inlet cross section at the door edges

Measurements in mm



Controls centered

Right-hinged

BX 480 112

Stainless steel-backed full glass door
Width 76 cm

Left-hinged

BX 481 112

Stainless steel-backed full glass door
Width 76 cm



Included in the price

- 2 baking trays, enamelled pyrolysis-safe
- 1 rotisserie spit
- 2 wire racks
- 2 grill trays with wire rack
- 1 plug-in core temperature probe

Special accessories

BA 018 105

Pull-out system
Fully extendable telescopic rails and enamelled cast iron frame.

BA 028 115

Baking tray, enamelled
30 mm deep.

BA 038 105

Wire rack, chromium-plated
Without opening, with feet.

BA 058 115

Heating element for baking stone and
Gastronorm roaster.

BA 058 133

Baking stone.
Incl. baking stone support and pizza
paddle (heating element must be
ordered separately).

Not in combination with pull-out system.

BS 020 002

Pizza paddle, set of 2.

GN 340 230

Gastronorm roaster in cast aluminium.
GN 2/3, height 165 mm, non-stick.

Double oven 400 series

BX 480/BX 481

- Pyrolytic system
- 17 heating methods with core temperature probe, rotisserie spit and baking stone function
- Core temperature probe with estimation of cooking time
- TFT touch display
- Electronic temperature control from 30 °C to 300 °C
- 2x 110 litres net volume

Heating methods

Hot air.
Eco hot air.
Top + bottom heat.
Top + 1/3 bottom heat.
Top heat.
1/3 top + bottom heat.
Bottom heat.
Hot air + bottom heat.
Hot air + 1/3 bottom heat.
Full surface grill + circulated air.
Full surface grill.
Compact grill.
Baking stone function.
Roaster function.
Dough proofing.
Defrosting.
Keeping warm.

Handling

Rotary knob and TFT touch display operation.
Clear text display.
Information key with use indicators.
Side-opening door opens up to 180° angle.

Features

Three-point core temperature probe with automatic shut-off and estimation of cooking time.
Rotisserie spit (lower oven).
Baking stone socket.
Actual temperature display.
Rapid heating.
Timer functions: cooking time, cooking time end, timer, stopwatch, long-term timer (certified by Star-K).
60 W halogen light on the top.
10 W halogen light on the side.
Enamelled side shelf supports with 5 tray levels, pyrolysis-safe.

Safety

Thermally insulated door with quadruple glazing.
Child lock.
Safety shut-off.
Cooled housing with temperature protection.

Cleaning

Pyrolytic system.
Gaggenau enamel.
Heated catalyser to clean the oven air.

Planning notes

Door hinge not reversible.
The facade of the appliance extends 47 mm from the furniture cavity.
Consider the overhang when planning to open drawers next to the appliance. When planning a corner solution, pay attention to the side-opening door and the minimum required distance to the wall.
To achieve the 550 mm installation depth, the connection cable needs to follow the slanted edge on the lower right hand corner of the housing. The mains socket needs to be planned outside the built-in niche.

Please read the installation details regarding oven combination on page 14 – 15.

Connection

Energy efficiency class A at a range of energy efficiency classes from A+++ to D.
Total connected load 9.2 kW.
Plan a connection cable.

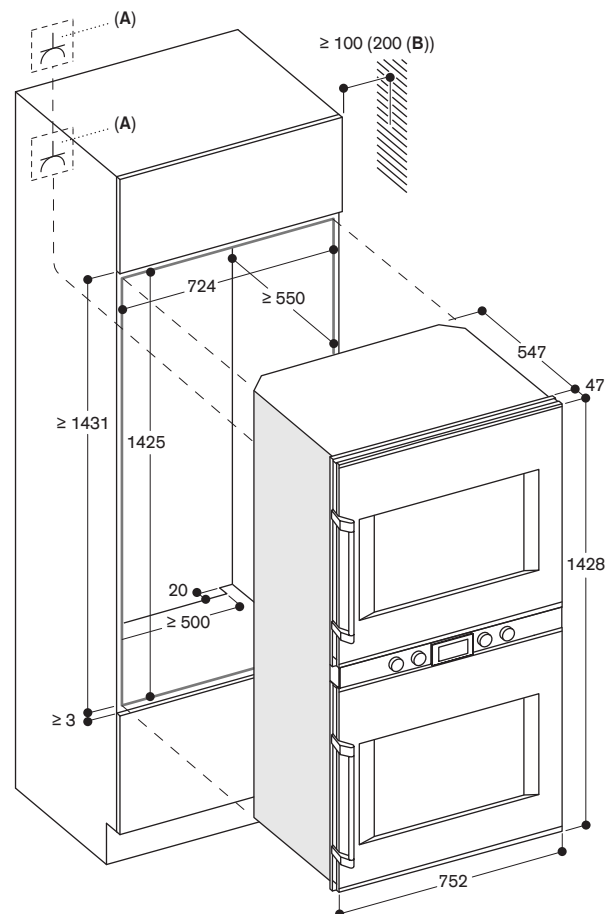
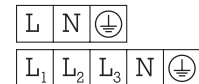

A: Electrical connection
B: 200 mm in conjunction with BA 018

Measurements in mm

*Energy efficiency class: at a range of energy efficiency classes from A+++ to D.



Controls at the top

Right-hinged

BO 480 112

Stainless steel-backed full glass door
Width 76 cm

Left-hinged

BO 481 112

Stainless steel-backed full glass door
Width 76 cm



Included in the price

- 1 baking tray, enamelled pyrolysis-safe
- 1 rotisserie spit
- 1 wire rack
- 1 grill tray with wire rack
- 1 plug-in core temperature probe

Special accessories

BA 018 105

Pull-out system

Fully extendable telescopic rails and enamelled cast iron frame.

BA 028 115

Baking tray, enamelled
30 mm deep.

BA 038 105

Wire rack, chromium-plated
Without opening, with feet.

BA 058 115

Heating element for baking stone and Gastronorm roaster.

BA 058 133

Baking stone.

Incl. baking stone support and pizza paddle (heating element must be ordered separately).

Not in combination with pull-out system.

BS 020 002

Pizza paddle, set of 2.

GN 340 230

Gastronorm roaster in cast aluminium.
GN 2/3, height 165 mm, non-stick.

Oven 400 series

BO 480/BO 481

- Handleless door / automatic door opening / door opening via voice assistant possible
- Pyrolytic system
- 17 heating methods with core temperature probe, rotisserie spit and baking stone function
- Automatic programmes
- Core temperature probe with estimation of cooking time
- TFT touch display
- Panel-free appliance with surface control module
- Electronic temperature control from 30 °C to 300 °C
- Net volume 110 litres

Heating methods

Hot air.

Eco hot air.

Top + bottom heat.

Top + 1/3 bottom heat.

Top heat.

1/3 top + bottom heat.

Bottom heat.

Hot air + bottom heat.

Hot air + 1/3 bottom heat.

Full surface grill + circulated air.

Full surface grill.

Compact grill.

Baking stone function.

Roaster function.

Dough proofing.

Defrosting.

Keeping warm.

Handling

Automatic door opening.

Rotary knob and TFT touch display operation.

Clear text display.

Option to save individual recipes (incl. core temperature probe).

Personalisation of automatic programmes.

Information key with use indicators.

Side-opening door opens up to 180° angle.

Features

Three-point core temperature probe with automatic shut-off and estimation of cooking time.

Automatic programmes.

Rotisserie spit.

Baking stone socket.

Actual temperature display.

Rapid heating.

Timer functions: cooking time, cooking time end, timer, stopwatch, long-term timer (certified by Star-K).

60 W halogen light on the top.

2 x 10 W halogen light on the side.

Enamelled side shelf supports with 5 tray levels, pyrolysis-safe.

Selected digital services (Home Connect)

Door opening via voice assistant.

Automatic programmes.

Remote monitoring and control.

Recipes.

Please read additional information on Home Connect on page 411.

Safety

Thermally insulated door with quadruple glazing.

Child lock.

Safety shut-off.

Cooled housing with temperature protection.

Cleaning

Pyrolytic system.

Gaggenau enamel.

Heated catalyser to clean the oven air.

Planning notes

Door hinge not reversible.

The facade of the appliance extends 47 mm from the furniture cavity.

Consider the overhang when planning to open drawers next to the appliance.

When planning a corner solution, pay attention to the side-opening door and the minimum required distance to the wall.

To achieve the 550 mm installation depth, the connection cable needs to follow the slanted edge on the lower right hand corner of the housing.

The mains socket needs to be planned outside the built-in niche. The LAN port can be found at the back on the upper right side.

The LAN port can be found at the back on the upper right side.

Please read the installation details regarding oven combination on page 14 – 15.

Connection

Energy efficiency class A at a range of energy efficiency classes from A+++ to D.

Total connected load 5.5 kW.

Plan a connection cable.

Plan a LAN cable.

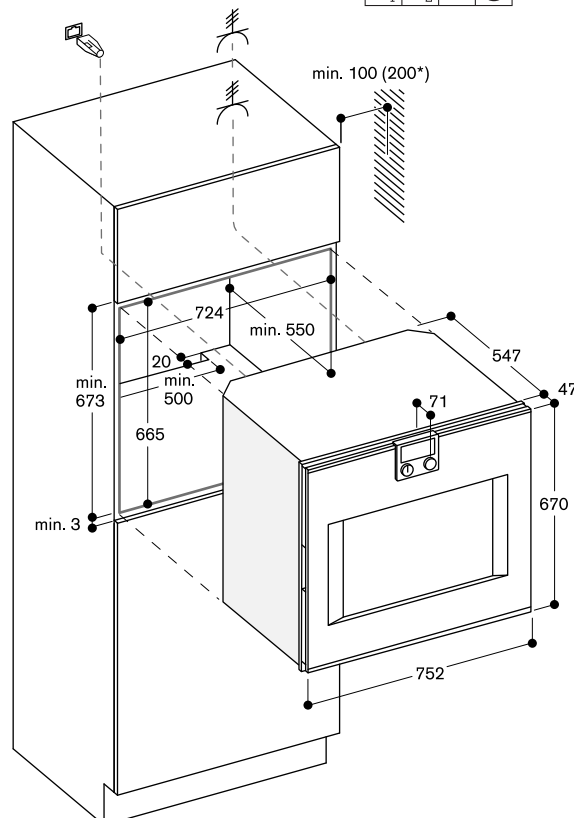
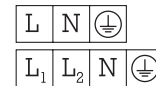

* 200 mm in conjunction with BA 018



Controls at the top

Right-hinged

BO 470 112

Stainless steel-backed full glass door

Width 60 cm

BO 470 102

Full glass door in Gaggenau Anthracite

Width 60 cm

Left-hinged

BO 471 112

Stainless steel-backed full glass door

Width 60 cm

BO 471 102

Full glass door in Gaggenau Anthracite

Width 60 cm



Included in the price

2 baking trays, enamelled pyrolysis-safe

1 rotisserie spit

1 glass tray

1 wire rack

1 grill tray with wire rack

1 plug-in core temperature probe

Special accessories

BA 016 105

Pull-out system

Fully extendable telescopic rails and enamelled cast iron frame.

BA 026 105

Grill tray, enamelled

30 mm deep.

BA 026 115

Baking tray, enamelled

15 mm deep.

BA 036 105

Wire rack, chromium-plated

Without opening, with feet.

BA 046 117

Glass tray

24 mm deep.

BA 056 115

Heating element for baking stone and Gastronorm roaster.

BA 056 133

Baking stone.

Incl. baking stone support and pizza paddle (heating element must be ordered separately).

Not in combination with pull-out system.

BS 020 002

Pizza paddle, set of 2.

GN 340 230

Gastronorm roaster in cast aluminium.

GN 2/3, height 165 mm, non-stick.

Oven 400 series

BO 470/BO 471

- Handleless door / automatic door opening / door opening via voice assistant possible
- Pyrolytic system
- 17 heating methods with core temperature probe, rotisserie spit and baking stone function
- Automatic programmes
- Core temperature probe with estimation of cooking time
- TFT touch display
- Panel-free appliance with surface control module
- Electronic temperature control from 30 °C to 300 °C
- Net volume 76 litres

Heating methods

Hot air.

Eco hot air.

Top + bottom heat.

Top + 1/3 bottom heat.

Top heat.

1/3 top + bottom heat.

Bottom heat.

Hot air + bottom heat.

Hot air + 1/3 bottom heat.

Full surface grill + circulated air.

Full surface grill.

Compact grill.

Baking stone function.

Roaster function.

Dough proofing.

Defrosting.

Keeping warm.

Handling

Automatic door opening.

Rotary knob and TFT touch display operation.

Clear text display.

Option to save individual recipes

(incl. core temperature probe).

Personalisation of automatic programmes.

Information key with use indicators.

Side-opening door opens up to

180° angle.

Features

Three-point core temperature probe with automatic shut-off and estimation of cooking time.

Automatic programmes.

Rotisserie spit.

Baking stone socket.

Actual temperature display.

Rapid heating.

Timer functions: cooking time, cooking

time end, timer, stopwatch, long-term

timer (certified by Star-K).

60 W halogen light on the top.

2 x 10 W halogen light on the side.

Enamelled side shelf supports with

4 tray levels, pyrolysis-safe.

Selected digital services

(Home Connect)

Door opening via voice assistant.

Automatic programmes.

Remote monitoring and control.

Recipes.

Please read additional information on Home Connect on page 411.

Safety

Thermally insulated door with quadruple glazing.

Child lock.

Safety shut-off.

Cooled housing with temperature protection.

Cleaning

Pyrolytic system.

Gaggenau enamel.

Heated catalyser to clean the oven air.

Planning notes

Door hinge not reversible.

The facade of the appliance extends 47 mm from the furniture cavity.

Consider the overhang when planning to open drawers next to the appliance.

When planning a corner solution, pay

attention to the side-opening door

and the minimum required distance

to the wall.

To achieve the 550 mm installation

depth, the connection cable needs to

follow the slanted edge on the lower

right hand corner of the housing.

The mains socket needs to be planned

outside the built-in niche.

The LAN port can be found at the back

on the upper right side.

Connection

Energy efficiency class A at a range of energy efficiency classes from A+++ to D.

Total connected load 3.7 kW.

Plan a connection cable.

Plan a LAN cable.

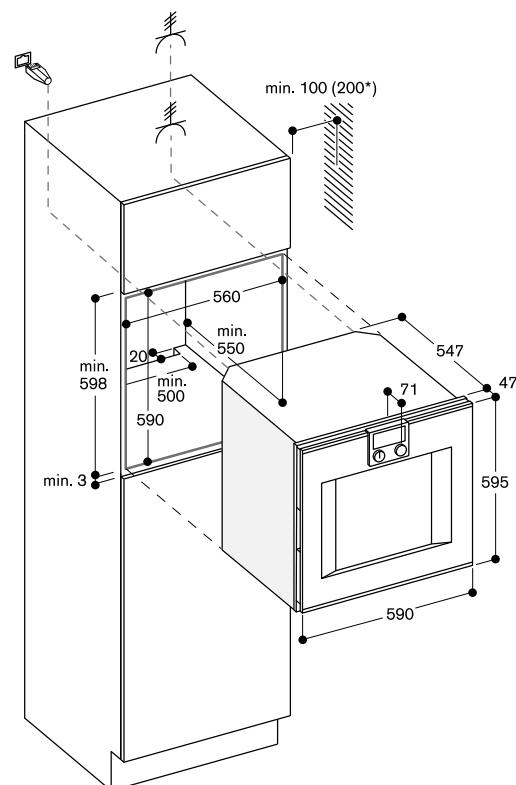

* 200 mm in conjunction with BA 016



Controls at the top

Right-hinged

BO 450 112

Stainless steel-backed full glass door
Width 60 cm

Left-hinged

BO 451 112

Stainless steel-backed full glass door
Width 60 cm

A

Included in the price

- 1 baking tray, enamelled pyrolysis-safe
- 1 glass tray
- 1 wire rack
- 1 plug-in core temperature probe

Special accessories

BA 016 105

Pull-out system
Fully extendable telescopic rails and enamelled cast iron frame.

BA 026 115

Baking tray, enamelled
15 mm deep.

BA 036 105

Wire rack, chromium-plated
Without opening, with feet.

BA 046 117

Glass tray
24 mm deep.

BA 056 115

Heating element for baking stone and Gastronorm roaster.

BA 056 133

Baking stone.
Incl. baking stone support and pizza paddle (heating element must be ordered separately).
Not in combination with pull-out system.

BA 226 105

Grill tray, enamelled
30 mm deep.

BS 020 002

Pizza paddle, set of 2.

GN 340 230

Gastronorm roaster in cast aluminium.
GN 2/3, height 165 mm, non-stick.

Oven 400 series

BO 450/BO 451

- Handleless door / automatic door opening / door opening via voice assistant possible
- Pyrolytic system
- 13 heating methods with core temperature probe and baking stone function
- Automatic programmes
- Core temperature probe with estimation of cooking time
- TFT touch display
- Panel-free appliance with surface control module
- Electronic temperature control from 30 °C to 300 °C
- Net volume 76 litres

Heating methods

Hot air.
Eco hot air.
Top + bottom heat.
Top heat.
Bottom heat.
Hot air + bottom heat.
Full surface grill + circulated air.
Full surface grill.
Compact grill.
Baking stone function.
Roaster function.
Dough proofing.
Defrosting.

Handling

Automatic door opening.
Rotary knob and TFT touch display operation.
Clear text display.
Option to save individual recipes (incl. core temperature probe).
Personalisation of automatic programmes.
Information key with use indicators.
Side-opening door opens up to 180° angle.

Features

Three-point core temperature probe with automatic shut-off and estimation of cooking time.
Automatic programmes.
Baking stone socket.
Actual temperature display.
Rapid heating.
Timer functions: cooking time, cooking time end, timer, stopwatch, long-term timer (certified by Star-K).
60 W halogen light on the top.
10 W halogen light on the side.
Enamelled side shelf supports with 4 tray levels, pyrolysis-safe.

Selected digital services

(Home Connect)

Door opening via voice assistant.
Automatic programmes.
Remote monitoring and control.
Recipes.

Please read additional information on Home Connect on page 411.

Safety

Thermally insulated door with quadruple glazing.
Child lock.
Safety shut-off.
Cooled housing with temperature protection.

Cleaning

Pyrolytic system.
Gaggenau enamel.
Heated catalyser to clean the oven air.

Planning notes

Door hinge not reversible.
The facade of the appliance extends 47 mm from the furniture cavity.
Consider the overhang when planning to open drawers next to the appliance.
When planning a corner solution, pay attention to the side-opening door and the minimum required distance to the wall.
To achieve the 550 mm installation depth, the connection cable needs to follow the slanted edge on the lower right hand corner of the housing.
The mains socket needs to be planned outside the built-in niche.
The LAN port can be found at the back on the upper right side.

Please read the installation details regarding oven combination on page 14 – 15.

Connection

Energy efficiency class A at a range of energy efficiency classes from A+++ to D.
Total connected load 3.7 kW.
Plan a connection cable.
Plan a LAN cable.

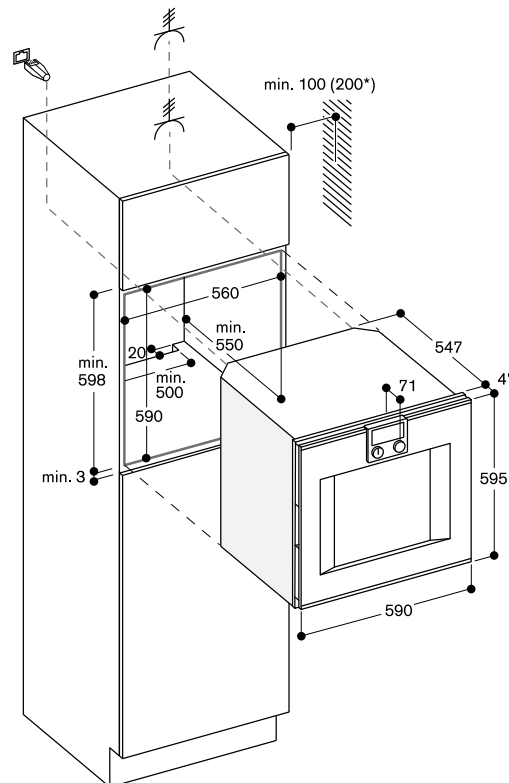

* 200 mm in conjunction with BA 016



Controls at the top

Right-hinged

BO 420 112

Stainless steel-backed full glass door
Width 60 cm

BO 420 102

Full glass door in Gaggenau Anthracite
Width 60 cm

Left-hinged

BO 421 112

Stainless steel-backed full glass door
Width 60 cm

BO 421 102

Full glass door in Gaggenau Anthracite
Width 60 cm



Included in the price

- 1 baking tray, enamelled pyrolysis-safe
- 1 glass tray
- 1 wire rack

Special accessories

BA 016 105

Pull-out system
Fully extendable telescopic rails and
enamelled cast iron frame.

BA 026 115

Baking tray, enamelled
15 mm deep.

BA 036 105

Wire rack, chromium-plated
Without opening, with feet.

BA 046 117

Glass tray
24 mm deep.

BA 056 115

Heating element for baking stone and
Gastronorm roaster.

BA 056 133

Baking stone.
Incl. baking stone support and pizza
paddle (heating element must be
ordered separately).
Not in combination with pull-out system.

BA 226 105

Grill tray, enamelled
30 mm deep.

BS 020 002

Pizza paddle, set of 2.

GN 340 230

Gastronorm roaster in cast aluminium.
GN2/3, height 165 mm, non-stick.

Oven 400 series

BO 420/BO 421

- Handleless door / automatic door opening
- Pyrolytic system
- 9 heating methods, with baking stone function
- TFT touch display
- Panel-free appliance with surface control module
- Electronic temperature control from 50 °C to 300 °C
- Net volume 76 litres

Heating methods

Hot air.
Eco hot air.
Top + bottom heat.
Top heat.
Bottom heat.
Hot air + bottom heat.
Full surface grill + circulated air.
Full surface grill.
Baking stone function.

Handling

Automatic door opening.
Rotary knob and TFT touch display operation.
Clear text display.
Option to save individual recipes.
Information key with use indicators.
Side-opening door opens up to 180° angle.

Features

Baking stone socket.
Actual temperature display.
Rapid heating.
Timer functions: cooking time, cooking time end, timer, stopwatch, long-term timer (certified by Star-K).
60 W halogen light on the top.
Enamelled side shelf supports with 4 tray levels, pyrolysis-safe.

Selected digital services (Home Connect)

Remote monitoring and control.
Recipes.

Please read additional information on Home Connect on page 411.

Safety

Thermally insulated door with quadruple glazing.
Child lock.
Safety shut-off.
Cooled housing with temperature protection.

Cleaning

Pyrolytic system.
Gaggenau enamel.
Heated catalyser to clean the oven air.

Planning notes

Door hinge not reversible.
The façade of the appliance extends 47 mm from the furniture cavity.
Consider the overhang, incl. the door handle where applicable, when planning to open drawers next to the appliance.
When planning a corner solution, pay attention to the side-opening door and the minimum required distance to the wall.

To achieve the 550 mm installation depth, the connection cable needs to follow the slanted edge on the lower right hand corner of the housing. The mains socket needs to be planned outside the built-in niche. The LAN port can be found at the back on the upper right side.

Please read the installation details regarding oven combination on page 14 – 15.

Connection

Energy efficiency class A at a range of energy efficiency classes from A+++ to D.
Total connected load 3.7 kW.
Plan a connection cable.
Plan a LAN cable.



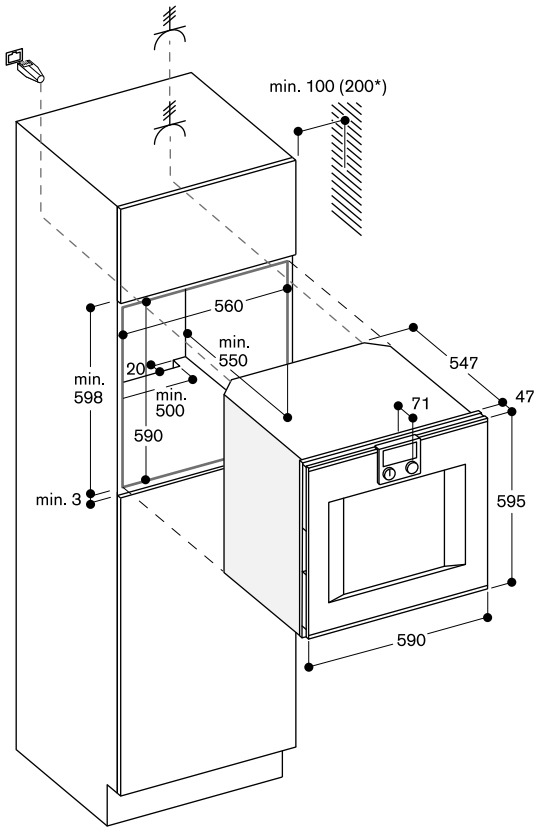

* 200 mm in conjunction with BA 016



Controls at the bottom

Right-hinged

BS 484 112

Stainless steel-backed full glass door
Width 76 cm

Left-hinged

BS 485 112

Stainless steel-backed full glass door
Width 76 cm



Included in the price

- 1 cooking container, stainless steel, perforated
- 1 cooking container, stainless steel, unperforated
- 1 wire rack
- 1 plug-in core temperature probe
- 1 outlet hose (3 m long)
- 1 water inlet hose (3 m long)
- 4 cleaning cartridges

Installation accessories

GF 111 100

Water descaling system

GF 121 110

Filter cartridge

GZ 010 011

Extension for water inlet and outlet
(2 m long)

Special accessories

BA 010 301

Triple telescopic pull-out rack
For combi-steam oven.

BA 020 361

Cooking container, stainless steel, unperforated, 46 mm deep, 5.4l.

BA 020 370

Cooking container, stainless steel, perforated, 40 mm deep, 5l.

BA 020 381

Cooking container, non-stick, unperforated, 46 mm deep, 5.4l.

BA 020 390

Cooking container, non-stick, perforated, 40 mm deep, 5l.

BA 046 117

Glass tray
24 mm deep.

CL S10 040

Cleaning cartridges, set of 4
For combi-steam ovens.

GN 010 330

Adapter for gastronorm insert and roaster.

GN 114 130

Gastronorm insert, stainless steel,
GN 1/3

Unperforated, 40 mm deep, 1.5l.

GN 114 230

Gastronorm insert, stainless steel,
GN 2/3

Unperforated, 40 mm deep, 3l.

GN 124 130

Gastronorm insert, stainless steel,
GN 1/3

Perforated, 40 mm deep, 1.5l.

Combi-steam oven 400 series

BS 484/BS 485

- Handleless door / automatic door opening / door opening via voice assistant possible
- Fixed inlet and outlet water connection
- Cleaning system, fully automatic
- Large cavity
- 2 LED light sources
- External steam generation
- Steaming without pressure
- Hot air 30 °C to 230 °C can be combined with chosen humidity level of 0%, 30%, 60%, 80% or 100%
- Sous-vide cooking with accurate temperature regulation
- Full surface grill behind glass ceramic, combinable with circulated air up to 230 °C and steam
- Automatic programmes
- Core temperature probe with estimation of cooking time
- Hot air fan rotates in both directions for ideal heat distribution
- TFT touch display
- Panel-free appliance with surface control module
- Electronic temperature control from 30 °C bis 230 °C
- Net volume 50 litres

Heating methods

Hot air + 100 % humidity.

Hot air + 80 % humidity.

Hot air + 60 % humidity.

Hot air + 30 % humidity.

Hot air + 0 % humidity.

Low temperature cooking.

Sous-vide cooking.

Full surface grill level 1 + humidity.

Full surface grill level 2 + humidity.

Full surface grill + circulated air.

Dough proofing.

Defrosting.

Regenerating.

Handling

Automatic door opening.

Rotary knob and TFT touch display operation.

Clear text display.

Option to save individual recipes

(incl. core temperature probe).

Personalisation of automatic programmes.

Information key with use indicators.

Side-opening door opens up to

180° angle.

Features

Full surface grill 2 kW behind glass ceramic.

Steam removal.

Misting.

Three-point core temperature probe with automatic shut-off and estimation of cooking time.

Automatic programmes.

Actual temperature display.

Timer functions: cooking time, cooking

time end, timer, stopwatch, long-term

timer (certified by Star-K).

Automatic boiling point detection.

2 x LED light on the side.

Hygienic stainless steel cooking interior.

3 tray levels.

GN 124 230

Gastronorm insert, stainless steel,
GN 2/3

Perforated, 40 mm deep, 3l.

GN 340 230

Gastronorm roaster in cast aluminium.

GN 2/3, height 165 mm, non-stick.

Selected digital services

(Home Connect)

Door opening via voice assistant.

Automatic programmes.

Remote control and monitoring.

Recipes.

Please read additional information on Home Connect on page 411.

Safety

Child lock.

Safety shut-off.

Cooled housing with temperature protection.

Cleaning

Cleaning programme, fully automatic.

Descaling programme for the steam generator.

Drying programme.

Automatic drying of the cavity at the end of the cooking process.

Strainer filter, removable.

Demo cleaning programme.

Planning notes

Door hinge not reversible.

No other electrical appliances should be installed above the BS.

At no point may the outlet hose be positioned higher than the bottom edge of the appliance. The outlet hose must also be at least 100 mm lower than the appliance outlet (see drawing "drainage connection").

Inlet hose can be extended once.

The outlet hose must not be longer than a maximum of 5 m.

The water connection (1) for the inlet hose must always be accessible and not located directly behind the appliance.

The connection of the outlet hose to the siphon (2) must not be directly behind the appliance and should be accessible.

The descaling system GF 111 100 (3) may be installed when connecting the appliance if the water hardness

exceeds 7° dH.

The facade of the appliance extends 47 mm from the furniture cavity.

Consider the overhang when planning to open drawers next to the appliance.

When planning a corner solution, pay attention to the side-opening door

and the minimum required distance to the wall.

The mains socket needs to be planned outside the built-in niche.

Special accessories (order as spare parts):

Part No. 17002490 Descaling tablets

Please read the installation details regarding oven combination on

page 14 – 15.

Connection

Energy efficiency class A at a range of energy efficiency classes from

A+++ to D.

Total connected load 3.15 kW.

Connecting cable 1.8 m with plug.

Plan a LAN cable.

Inlet hose 3,0 m with connection pipe thread

ISO228-G 3/4" (Ø 26,4 mm) extendable.

Outlet hose (Ø 25 mm) 3,0 m (HT-Hose).



*Energy efficiency class: at a range of energy efficiency classes from A+++ to D.

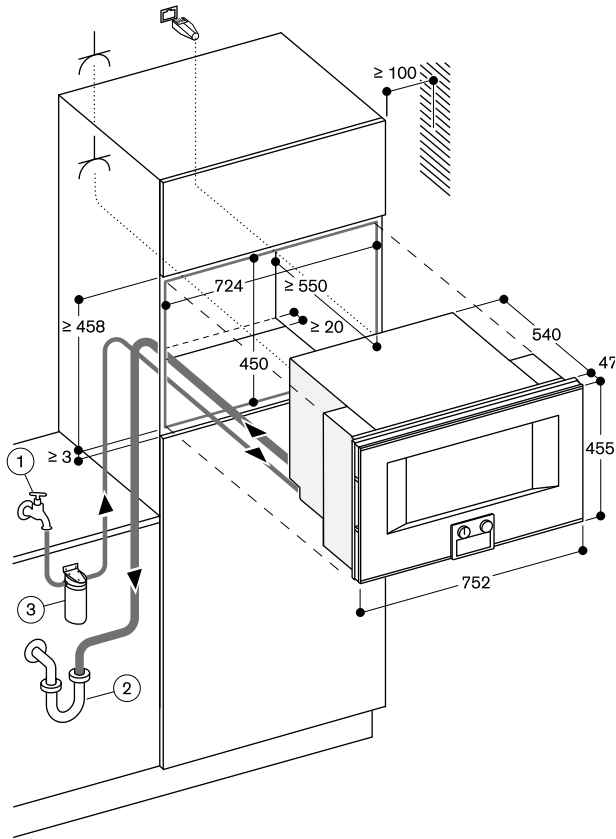

Socket

measurements in mm

Side view of BS 484/485 above BO

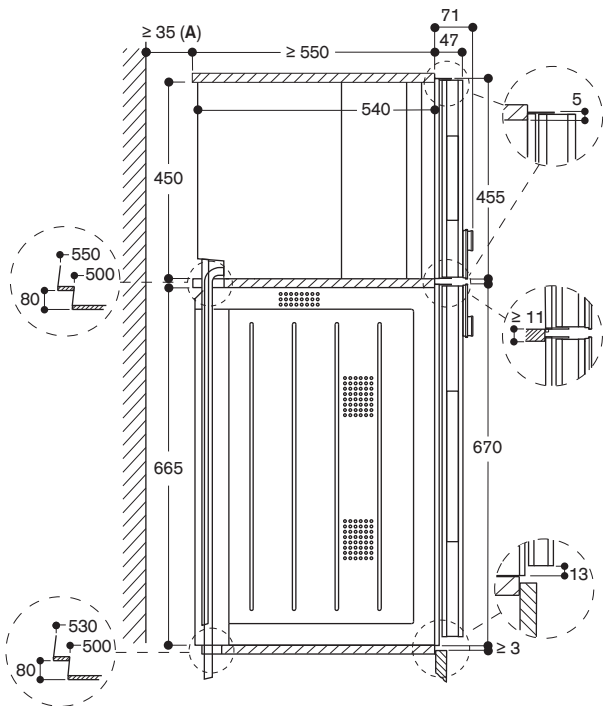

A: Only required if the water hoses for the BS steam oven cannot be accommodated in the corner recesses of the appliances.

measurements in mm

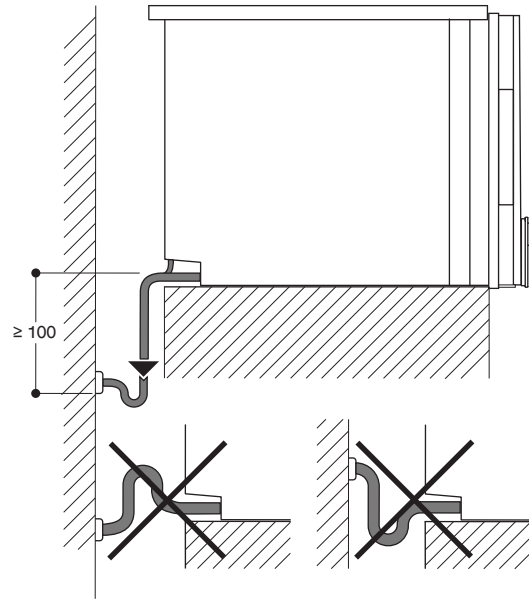

measurements in mm

View from rear

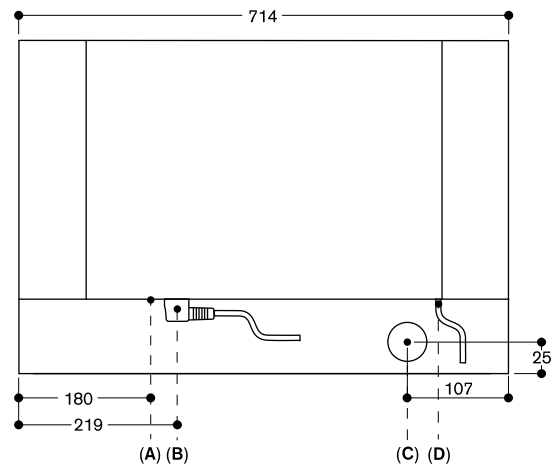

- A: LAN connection
- B: Electric terminal box
- C: Water outlet
- D: Cold water inlet

measurements in mm



Controls at the top

Right-hinged

BS 470 112

Stainless steel-backed full glass door
Width 60 cm

BS 470 102

Full glass door in Gaggenau Anthracite
Width 60 cm

Left-hinged

BS 471 112

Stainless steel-backed full glass door
Width 60 cm

BS 471 102

Full glass door in Gaggenau Anthracite
Width 60 cm

Controls at the bottom

Right-hinged

BS 474 112

Stainless steel-backed full glass door
Width 60 cm

BS 474 102

Full glass door in Gaggenau Anthracite
Width 60 cm

Left-hinged

BS 475 112

Stainless steel-backed full glass door
Width 60 cm

BS 475 102

Full glass door in Gaggenau Anthracite
Width 60 cm



Included in the price

- 1 cooking container, stainless steel, perforated
- 1 cooking container, stainless steel, unperforated
- 1 wire rack
- 1 plug-in core temperature probe
- 1 outlet hose (3 m long)
- 1 water inlet hose (3 m long)
- 4 cleaning cartridges

Installation accessories

GF 111 100

Water descaling system

GF 121 110

Filter cartridge

GZ 010 011

Extension for water inlet and outlet
(2 m long)

Special accessories

BA 010 301

Triple telescopic pull-out rack
For combi-steam oven.

BA 020 361

Cooking container, stainless steel,
unperforated, 46 mm deep, 5.4 l.

BA 020 370

Cooking container, stainless steel,
perforated, 40 mm deep, 5 l.

BA 020 381

Cooking container, non-stick,
unperforated, 46 mm deep, 5.4 l.

Combi-steam oven 400 series

BS 470/BS 471/BS 474/BS 475

- Handleless door / automatic door opening / door opening via voice assistant possible
- Fixed inlet and outlet water connection
- Cleaning system, fully automatic
- Large cavity
- 2 LED light sources
- External steam generation
- Steaming without pressure
- Hot air 30 °C to 230 °C can be combined with chosen humidity level of 0%, 30%, 60%, 80% or 100%
- Sous-vide cooking with accurate temperature regulation
- Full surface grill behind glass ceramic, combinable with circulated air up to 230 °C and steam
- Automatic programmes
- Core temperature probe with estimation of cooking time
- Hot air fan rotates in both directions for ideal heat distribution
- TFT touch display
- Panel-free appliance with surface control module
- Electronic temperature control from 30 °C bis 230 °C
- Net volume 50 litres

Heating methods

- Hot air + 100 % humidity.
- Hot air + 80 % humidity.
- Hot air + 60 % humidity.
- Hot air + 30 % humidity.
- Hot air + 0 % humidity.
- Low temperature cooking.
- Sous-vide cooking.
- Full surface grill level 1 + humidity.
- Full surface grill level 2 + humidity.
- Full surface grill + circulated air.
- Dough proofing.
- Defrosting.
- Regenerating.

Handling

- Automatic door opening.
- Rotary knob and TFT touch display operation.
- Clear text display.
- Option to save individual recipes (incl. core temperature probe).
- Personalisation of automatic programmes.
- Information key with use indicators.
- Side-opening door opens up to 180° angle.

Features

- Full surface grill 2 kW behind glass ceramic.
- Steam removal.
- Misting.
- Three-point core temperature probe with automatic shut-off and estimation of cooking time.
- Automatic programmes.
- Actual temperature display.
- Timer functions: cooking time, cooking time end, timer, stopwatch, long-term timer (certified by Star-K).
- Automatic boiling point detection.
- 2 x LED light on the side.
- Hygienic stainless steel cooking interior.
- 3 tray levels.

BA 020 390

Cooking container, non-stick,
perforated, 40 mm deep, 5 l.

BA 046 117

Glass tray

24 mm deep.

CL S10 040

Cleaning cartridges, set of 4
For combi-steam ovens.

GN 010 330

Adapter for gastronorm insert and roaster.

GN 114 130

Gastronorm insert, stainless steel,
GN 1/3

Unperforated, 40 mm deep, 1.5 l.

GN 114 230

Gastronorm insert, stainless steel,
GN 2/3

Unperforated, 40 mm deep, 3 l.

GN 124 130

Gastronorm insert, stainless steel,
GN 1/3

Perforated, 40 mm deep, 1.5 l.

GN 124 230

Gastronorm insert, stainless steel,
GN 2/3

Perforated, 40 mm deep, 3 l.

GN 340 230

Gastronorm roaster in cast aluminium.
GN 2/3, height 165 mm, non-stick.

Selected digital services

(Home Connect)

- Door opening via voice assistant.
- Automatic programmes.
- Remote control and monitoring.
- Recipes.

Please read additional information on Home Connect on page 411.

Safety

- Child lock.
- Safety shut-off.
- Cooled housing with temperature protection.

Cleaning

- Cleaning programme, fully automatic.
- Descaling programme for the steam generator.
- Drying programme.
- Automatic drying of the cavity at the end of the cooking process.
- Strainer filter, removable.
- Demo cleaning programme.

Planning notes

- Door hinge not reversible.
- No other electrical appliances should be installed above the BS.
- At no point may the outlet hose be positioned higher than the bottom edge of the appliance. The outlet hose must also be at least 100 mm lower than the appliance outlet (see drawing "drainage connection").
- Inlet hose can be extended once.
- The outlet hose must not be longer than a maximum of 5 m.
- The water connection (1) for the inlet hose must always be accessible and not located directly behind the appliance.
- The connection of the outlet hose to the siphon (2) must not be directly behind the appliance and should be accessible.
- The descaling system GF 111 100 (3) may be installed when connecting the appliance if the water hardness exceeds 7° dH.
- The facade of the appliance extends 47 mm from the furniture cavity.
- Consider the overhang when planning to open drawers next to the appliance.
- When planning a corner solution, pay attention to the side-opening door and the minimum required distance to the wall.
- The mains socket needs to be planned outside the built-in niche.

Special accessories (order as spare parts):
Part No. 17002490 Descaling tablets

Please read the installation details regarding oven combination on page 14 – 15.

Connection

- Energy efficiency class A at a range of energy efficiency classes from A+++ to D.
- Total connected load 3.15 kW.
- Connecting cable 1.8 m with plug.
- Plan a LAN cable.
- Inlet hose 3,0 m with connection pipe thread ISO228-G 3/4" (Ø 26,4 mm) extendable.
- Outlet hose (Ø 25 mm) 3,0 m (HT-Hose).



*Energy efficiency class: at a range of energy efficiency classes from A+++ to D.

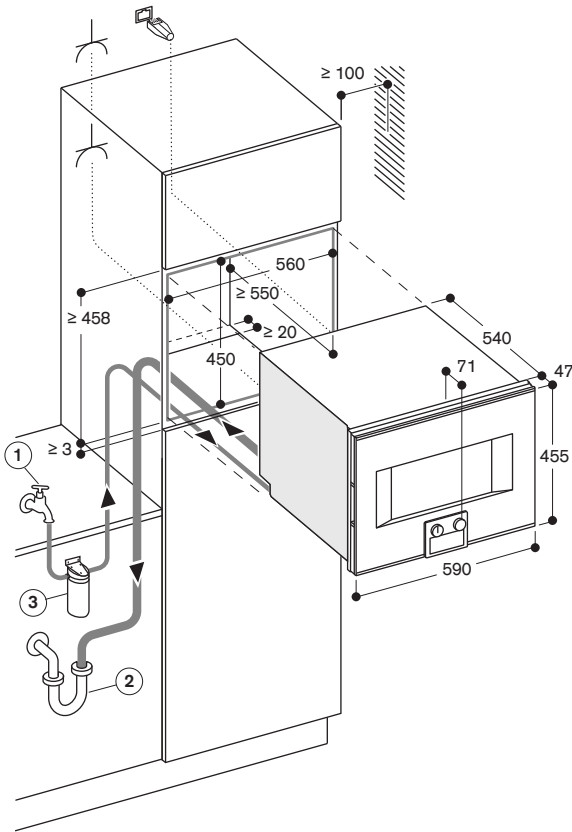

Socket

measurements in mm

Side view of BS 474/475 above BO

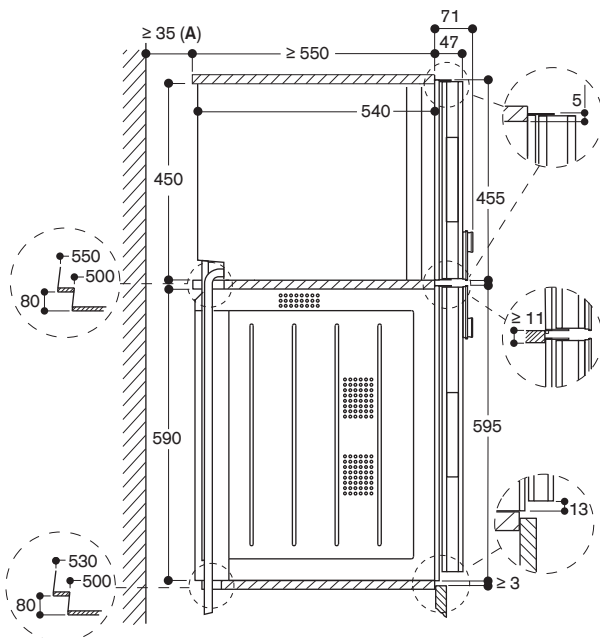

A: Only required if the water hoses for the BS steam oven cannot be accommodated in the corner recesses of the appliances.

measurements in mm

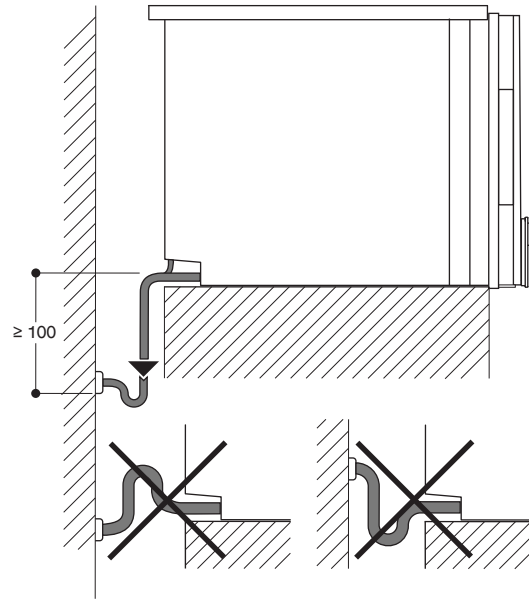

measurements in mm

View from rear

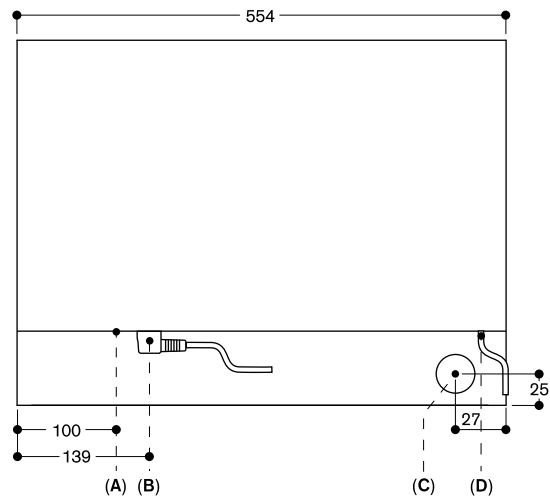

- A: LAN connection
- B: Electric terminal box
- C: Water outlet
- D: Cold water inlet

measurements in mm



Controls at the top

Right-hinged

BS 450 111

Stainless steel-backed full glass door
Width 60 cm

BS 450 101

Full glass door in Gaggenau Anthracite
Width 60 cm

Left-hinged

BS 451 111

Stainless steel-backed full glass door
Width 60 cm

BS 451 101

Full glass door in Gaggenau Anthracite
Width 60 cm

Controls at the bottom

Right-hinged

BS 454 111

Stainless steel-backed full glass door
Width 60 cm

BS 454 101

Full glass door in Gaggenau Anthracite
Width 60 cm

Left-hinged

BS 455 111

Stainless steel-backed full glass door
Width 60 cm

BS 455 101

Full glass door in Gaggenau Anthracite
Width 60 cm



Included in the price

- 1 cooking container, stainless steel, perforated
- 1 cooking container, stainless steel, unperforated
- 1 wire rack
- 1 plug-in core temperature probe
- 4 cleaning cartridges

Special accessories

BA 010 301

Triple telescopic pull-out rack
For combi-steam oven.

BA 020 361

Cooking container, stainless steel, unperforated, 46 mm deep, 5.4 l.

BA 020 370

Cooking container, stainless steel, perforated, 40 mm deep, 5 l.

BA 020 381

Cooking container, non-stick, unperforated, 46 mm deep, 5.4 l.

BA 020 390

Cooking container, non-stick, perforated, 40 mm deep, 5 l.

BA 046 117

Glass tray
24 mm deep.

CL S10 040

Cleaning cartridges, set of 4
For combi-steam ovens.

Combi-steam oven 400 series

BS 450/BS 451/BS 454/BS 455

- Handleless door / automatic door opening / door opening via voice assistant possible
- Water tank for fresh and waste water
- Cleaning system, fully automatic
- Large cavity
- 2 LED light sources
- External steam generation
- Steaming without pressure
- Hot air 30 °C to 230 °C can be combined with chosen humidity level of 0%, 30%, 60%, 80% or 100%
- Sous-vide cooking with accurate temperature regulation
- Full surface grill behind glass ceramic, combinable with circulated air up to 230 °C and steam
- Automatic programmes
- Core temperature probe with estimation of cooking time
- Hot air fan rotates in both directions for ideal heat distribution
- TFT touch display
- Panel-free appliance with surface control module
- Electronic temperature control from 30 °C bis 230 °C
- Net volume 50 litres

Heating methods

Hot air + 100 % humidity.

Hot air + 80 % humidity.

Hot air + 60 % humidity.

Hot air + 30 % humidity.

Hot air + 0 % humidity.

Low temperature cooking.

Sous-vide cooking.

Full surface grill level 1 + humidity.

Full surface grill level 2 + humidity.

Full surface grill + circulated air.

Dough proofing.

Defrosting.

Regenerating.

Handling

Automatic door opening.

Rotary knob and TFT touch display operation.

Clear text display.

Option to save individual recipes

(incl. core temperature probe).

Personalisation of automatic programmes.

Information key with use indicators.

Side-opening door opens up to

180° angle.

Features

Full surface grill 2 kW behind glass ceramic.

2 removable 1.7 litre water tanks.

Misting.

Water level warning.

Three-point core temperature probe with automatic shut-off and estimation of cooking time.

Automatic programmes.

Actual temperature display.

Timer functions: cooking time, cooking

time end, timer, stopwatch, long-term

timer (certified by Star-K).

Automatic boiling point detection.

2 x LED light on the side.

Hygienic stainless steel cooking interior.

3 tray levels.

GN 010 330

Adapter for gastronorm insert and roaster.

GN 114 130

Gastronorm insert, stainless steel, GN 1/3

Unperforated, 40 mm deep, 1.5 l.

GN 114 230

Gastronorm insert, stainless steel, GN 2/3

Unperforated, 40 mm deep, 3 l.

GN 124 130

Gastronorm insert, stainless steel, GN 1/3

Perforated, 40 mm deep, 1.5 l.

GN 124 230

Gastronorm insert, stainless steel, GN 2/3

Perforated, 40 mm deep, 3 l.

GN 340 230

Gastronorm roaster in cast aluminium. GN 2/3, height 165 mm, non-stick.

Selected digital services

(Home Connect)

Door opening via voice assistant.

Automatic programmes.

Remote control and monitoring.

Recipes.

Please read additional information on Home Connect on page 411.

Safety

Child lock.

Safety shut-off.

Cooled housing with temperature protection.

Cleaning

Cleaning programme, fully automatic.

Descaling programme for the steam generator.

Drying programme.

Automatic drying of the cavity at the end of the cooking process.

Strainer filter, removable.

Water tank, dishwasher-safe.

Demo cleaning programme.

Planning notes

Door hinge not reversible.

No other electrical appliances should be installed above the BS.

The facade of the appliance extends 47 mm from the furniture cavity.

Consider the overhang when planning to open drawers next to the appliance.

When planning a corner solution, pay attention to the side-opening door and the minimum required distance to the wall.

The mains socket needs to be planned outside the built-in niche.

The LAN port can be found at the back on the lower left side.

Special accessories (order as spare parts):

Part No. 17002490 Descaling tablets

Please read the installation details regarding oven combination on page 14 – 15.

Connection

Energy efficiency class A at a range of energy efficiency classes from A+++ to D.

Total connected load 3.15 kW.

Connecting cable 1.8 m with plug.

Plan a LAN cable.



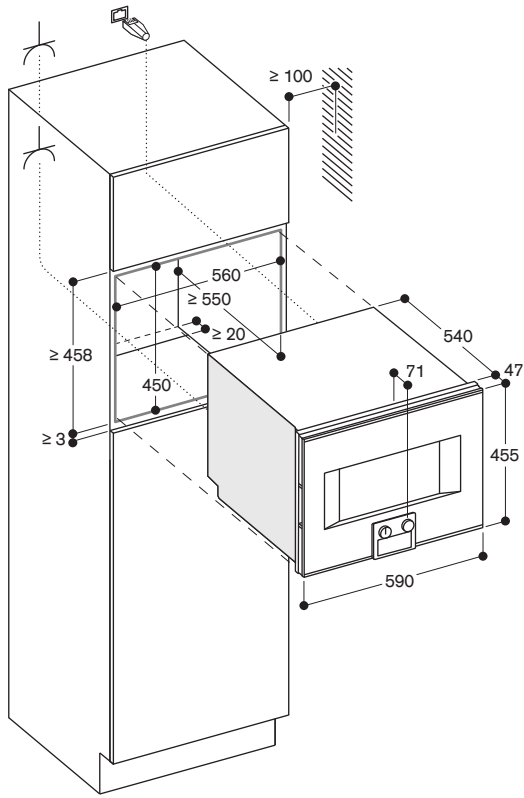

Socket

measurements in mm

Side view of BS 454/455 above BO

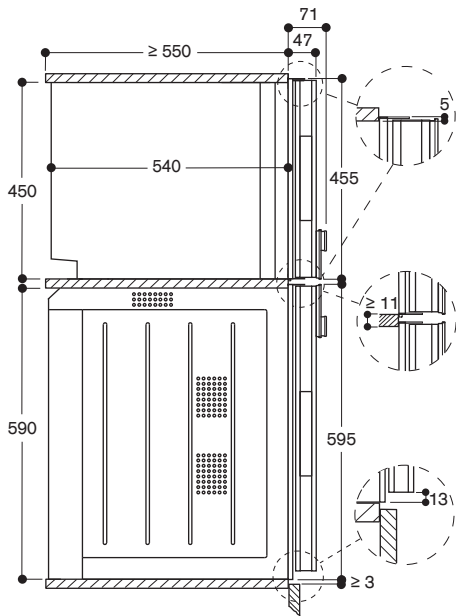

measurements in mm



Controls at the bottom

Right-hinged

BM 484 110

Stainless steel-backed full glass door
Width 76 cm

Left-hinged

BM 485 110

Stainless steel-backed full glass door
Width 76 cm

Included in the price

- 1 combination wire rack
- 1 glass tray

Combi-microwave oven 400 series
BM 484/BM 485

- Handleless door / automatic door opening
- Single operation and combination of microwave, grill and oven
- Sequential operation of up to 5 modes incl. programming of combined operation and rest time
- TFT touch display
- Panel-free appliance with surface control module
- Electronic temperature control
- Interior volume 36 litres

Programmes

Microwave operation with 5 output levels: 1000, 600, 360, 180, 90 W.
Oven operation with 4 heating methods: Hot air 40 °C and from 100 °C to 250 °C, Full surface grill + hot air from 100 °C to 250 °C, Full surface grill + circulated air from 100 °C to 250 °C, Full surface grill with 3 levels of intensity, maximum output 2000 W. Heating methods with microwave output levels 600, 360, 180 and 90 W freely combinable.
15 automatic programmes with weight indication, customisable:
4 defrosting programmes
4 cooking programmes
7 combination programmes
Option to save individual recipes.

Handling

Automatic door opening.
Rotary knob and TFT touch display operation.
Clear text display.
Information key with use indicators.
Side-opening door opens up to 180° angle.

Features

Innowave.
Rapid heating.
4 tray levels.
Actual temperature display.
60 W halogen light on the side.
Timer functions: cooking time, cooking time end, timer, stopwatch, long-term timer (certified by Star-K).

Safety

Thermally insulated door with triple glazing.
Triple door lock.
Child lock.
Safety shut-off.
Cooled housing with temperature protection.

Cleaning

Hygienic stainless steel interior with glass ceramic base.
Interior back wall with catalytic coating.

Planning notes

Door hinge not reversible.
The door panel surface of the appliance extends 47 mm from the furniture cavity.
Consider the overhang, incl. the door handle where applicable, when planning to open drawers next to the appliance.

When planning a corner solution, pay attention to the side-opening door and the minimum required distance to the wall.
The mains socket needs to be planned outside of the built-in niche.

Please read the installation details regarding oven combination on page 14 – 15.

Connection

Total connected load 3.1 kW.
Connection cable 1.5 m without plug.

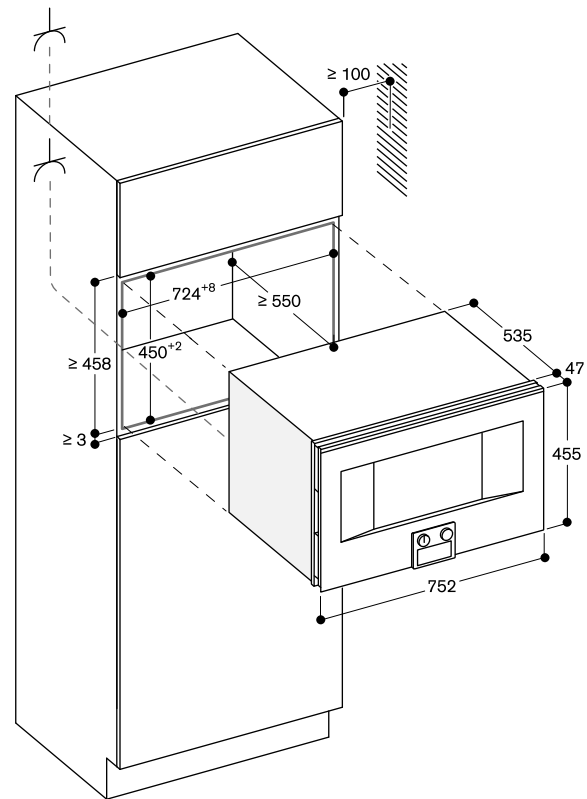

Socket

measurements in inches (mm)

Side view of BM 484/485 above BO

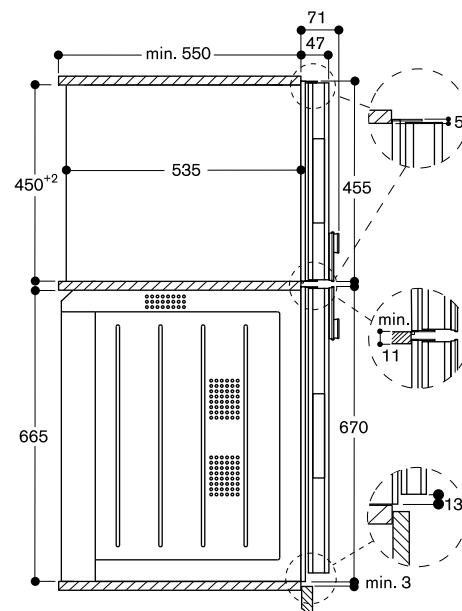



Controls at the top

Right-hinged

BM 450 110

Stainless steel-backed full glass door
Width 60 cm

BM 450 100

Full glass door in Gaggenau Anthracite
Width 60 cm

Left-hinged

BM 451 110

Stainless steel-backed full glass door
Width 60 cm

BM 451 100

Full glass door in Gaggenau Anthracite
Width 60 cm

Controls at the bottom

Right-hinged

BM 454 110

Stainless steel-backed full glass door
Width 60 cm

BM 454 100

Full glass door in Gaggenau Anthracite
Width 60 cm

Left-hinged

BM 455 110

Stainless steel-backed full glass door
Width 60 cm

BM 455 100

Full glass door in Gaggenau Anthracite
Width 60 cm

Included in the price

- 1 combination wire rack
- 1 glass tray

Combi-microwave oven 400 series BM 450/BM 451/BM 454/BM 455

- Handleless door / automatic door opening
- Single operation and combination of microwave, grill and oven
- Sequential operation of up to 5 modes incl. programming of combined operation and rest time
- TFT touch display
- Panel-free appliance with surface control module
- Electronic temperature control
- Interior volume 36 litres

Programmes

Microwave operation with 5 output levels: 1000, 600, 360, 180, 90 W.
Oven operation with 4 heating methods: Hot air 40 °C and from 100 °C to 250 °C, Full surface grill + hot air from 100 °C to 250 °C, Full surface grill + circulated air from 100 °C to 250 °C, Full surface grill with 3 levels of intensity, maximum output 2000 W.
Heating methods with microwave output levels 600, 360, 180 and 90 W freely combinable.
15 automatic programmes with weight indication, customisable:
4 defrosting programmes
4 cooking programmes
7 combination programmes
Option to save individual recipes.

Handling

Automatic door opening.
Rotary knob and TFT touch display operation.
Clear text display.
Information key with use indicators.
Side-opening door opens up to 180° angle.

Features

Innowave.
Rapid heating.
4 tray levels.
Actual temperature display.
60 W halogen light on the side.
Timer functions: cooking time, cooking time end, timer, stopwatch, long-term timer (certified by Star-K).

Safety

Thermally insulated door with triple glazing.
Triple door lock.
Child lock.
Safety shut-off.
Cooled housing with temperature protection.

Cleaning

Hygienic stainless steel interior with glass ceramic base.
Interior back wall with catalytic coating.

Planning notes

Door hinge not reversible.
Plan the niche without back wall.
The door panel surface of the appliance extends 47 mm from the furniture cavity.
Consider the overhang, incl. the door handle where applicable, when planning to open drawers next to the appliance.

When planning a corner solution, pay attention to the side-opening door and the minimum required distance to the wall.

The mains socket needs to be planned outside of the built-in niche.

Please read the installation details regarding oven combination on page 14 – 15.

Connection

Total connected load 3.1 kW.

Connection cable 1.5 m without plug.

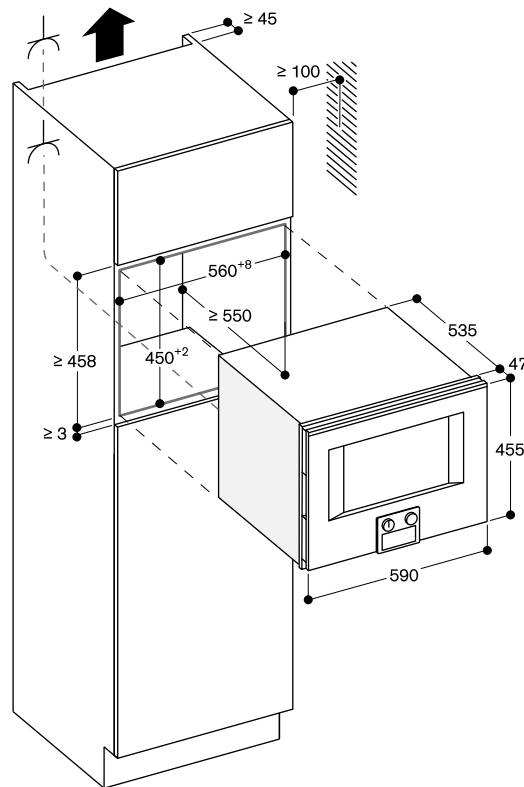

⚡ Socket

measurements in mm

Side view of BM 454/455 above BO

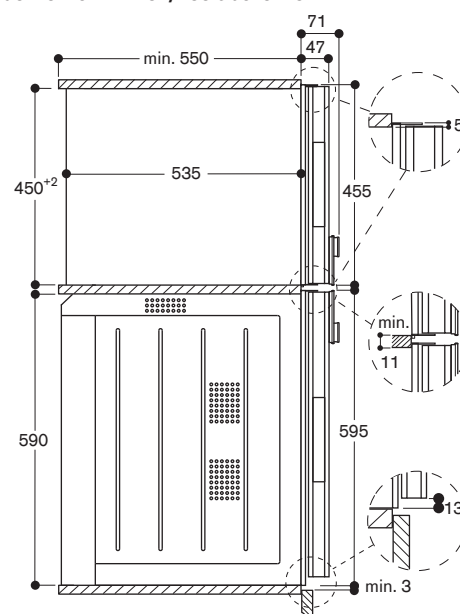



Controls at the top

Left-hinged

CM 450 112

Stainless steel-backed full glass door

Width 60 cm

CM 450 102

Full glass door in Gaggenau Anthracite

Width 60 cm

Included in the price

- 1 assembly screws
- 1 scoop
- 1 test strip
- 1 milk container (insulated)
- 1 connection hose for milk frother
- 1 milk pipe

Fully automatic espresso machine

400 series

CM 450

- Handleless door / automatic door opening
- Continuous flow heater means no waiting time and constant brewing temperature
- Aroma brewing technology for a full aroma
- Single portion cleaning
- TFT touch display
- Panel-free appliance with surface control module
- One-touch operation
- Personalisation function
- 7 light settings
- Electronic fill level control for milk, water and coffee to ensure a perfect result

Type of beverage

Ristretto / 2 x Ristretto.
 Espresso / 2 x Espresso.
 Espresso Macchiato / 2 x Espresso Macchiato.
 Coffee / 2 x Coffee.
 Americano / 2 x Americano.
 Caffè Latte / 2 x Caffè Latte.
 Latte Macchiato / 2 x Latte Macchiato.
 Cappuccino / 2 x Cappuccino.
 Flat White / 2 x Flat White.
 Milk froth / 2 x Milk froth.
 Warm milk / 2 x Warm milk.
 Hot water / 2 x Hot water.

Handling

Automatic door opening.
 Rotary knob and TFT touch display operation.
 Clear text display.
 Personalisation function, option to save 8 individualised beverages.
 4 beverage size settings, volume can be individually adjusted to match the size of the cup.
 8 coffee strength levels from very mild to extra strong.
 3 coffee temperature levels.
 10 hot water temperature levels.
 4 coffee-milk ratio levels.
 Adjustable grinding level.
 Height-adjustable coffee dispenser 7 cm to 15 cm.
 Easy access to water tank, milk and coffee bean container behind the door.

Features

Maintenance-free grinding unit with ceramic discs.
 Separate drawer for second ground coffee type.
 Water pump with 19 bar pressure.
 Double grinding and brewing cycles for extra intensity for single beverage order.
 For double beverage order, two grinding and brewing cycles.
 Beverage dispenser with integrated milk system.
 Insulated stainless steel milk container for up to 0.5 litres.
 Integrated lighting with LEDs.
 Removable bean container with aroma protecting lid for 500 g allows for an effortless exchange of different types of coffee beans.
 Automatic adjustment of ground coffee quantity.
 Removable 2.4 litre water tank.
 Electronic water filter exchange indicator.

Electronic fill level control for drip tray and container for coffee residue.
 Hint: for energy-saving, the appliance switches to standby mode automatically after about 30 minutes. This timespan can be changed in the basic settings.

Selected digital services (Home Connect)

Coffee world: extended choice of coffee specialities from all over the world.
 Remote control and monitoring.

Please read additional information on Home Connect on page 411.

Safety

Child lock.

Cleaning

Fully automatic rinse programme when machine is turned on/off.
 Automatic steam cleaning of the milk system after every beverage.
 Automatic cleaning and descaling programme.
 Emptying programme to prepare the appliance for holiday or transportation.
 Empty-grinding function to remove coffee residues from the system when switching bean types.
 Removable brewing unit.
 Dishwasher-safe coffee residue container and drip tray.
 Dishwasher-safe beverage dispenser.

Planning notes

Ideal installation height 95 cm to 145 cm (top edge of niche bottom).
 The door panel surface of the appliance extends 47 mm from the furniture cavity.
 When installing in a corner a side clearance is required.
 Door opening angle appr. 110° (delivery status) - mounting distance to the wall has to be at least 350 mm.
 Door opening angle appr. 155° - mounting distance to the wall has to be at least 650 mm.
 Door opening angle appr. 92° - mounting distance to the wall has to be at least 100 mm (spare part No. 00636455).
 Installation directly above 14 cm high warming drawer in 59 cm standardised niche.
 The LAN port can be found at the back on the lower right side.

Special accessories (order as spare parts - see also page 42 - 43):
 Part No. 17000705 Water filter
 Part No. region-specific Descaling tablets
 Part No. region-specific Cleaning tablets
 Part No. 00636455 Door hinge restrictor (92° opening angle)
 Part No. 11015223 Bean container with lid

Please read the installation details regarding oven combination on page 14 - 15.

Connection

Total connected load 1.6 kW.
 Connection cable 1.7 m with plug.
 Plan a LAN cable.

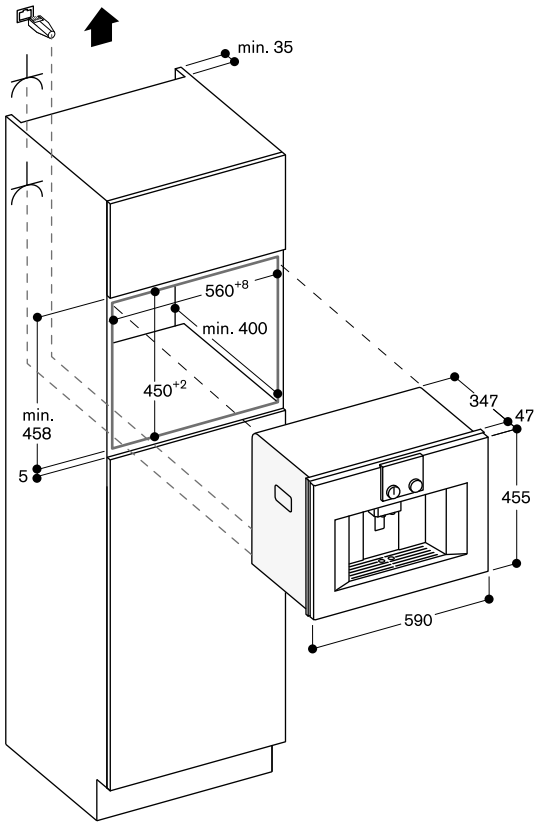



DV 461 110

Stainless steel-backed glass front
Width 60 cm, Height 14 cm

DV 461 100

Glass front in Gaggenau Anthracite
Width 60 cm, Height 14 cm

Included in the price

- 50 vacuuming bags, small
- 50 vacuuming bags, big
- 1 raised vacuuming platform
- 1 adaptor f. vacuuming outside the chamber
- 1 vacuuming hose
- 1 adaptor for bottle plugs
- 3 plugs for vacuuming of bottles

Vacuating drawer 400 series

DV 461

- Integrable in 14 cm high niche
- Hygienic stainless steel vacuuming chamber, applicable height up to 80 mm
- 3 vacuuming levels for vacuuming in the chamber, max. 99%
- 3 vacuuming levels for vacuuming outside the chamber, max. 90%
- Automatic connection recognition for vacuuming outside the chamber
- Handleless drawer
- Cushioned closing system

Application

Vacuating for sous-vide cooking.
Vacuuing for fast marinating and flavouring.
Vacuuing for extended storage.
Vacuuing of vacuuming containers outside the chamber.
Vacuuing of liquids in bottles outside the chamber.

Handling

Touch key operation.
Recessed grip at the front bottom of the drawer.

Features

Net volume 7 litres.
Capacity load max. 10 kg.
Maximum size of vacuuming bags
W 240 mm x L 350 mm.
3 heat-sealing levels for different strengths of bag material.
Sealing bar, non-stick coating, removable.
Safety glass cover, opens automatically after vacuuming.
Raised vacuuming platform, 44 mm, deployable.
Utility space in vacuuming chamber, W 210 mm x L 275 mm.
Membrane for avoiding reflow of liquids during vacuuming outside the chamber.
Drying programme for vacuuming pump.
Warning function.

Planning notes

The panel surface of the appliance extends 47 mm from the furniture cavity.
Installation of BS/BM/CM directly above DV in 59 cm niche without intermediate floor.
Built-in under worktop or in single niche.
The socket can be planned behind the appliance.

Special accessories
(order as spare parts):
Part No. 00578813
vacuuming bags, small
Part No. 00578814
vacuuming bags, big

Please read the installation details regarding oven combination on page 14 – 15.

Connection

Total connected load 0.32 kW.
Connection cable 1.5 m, pluggable.

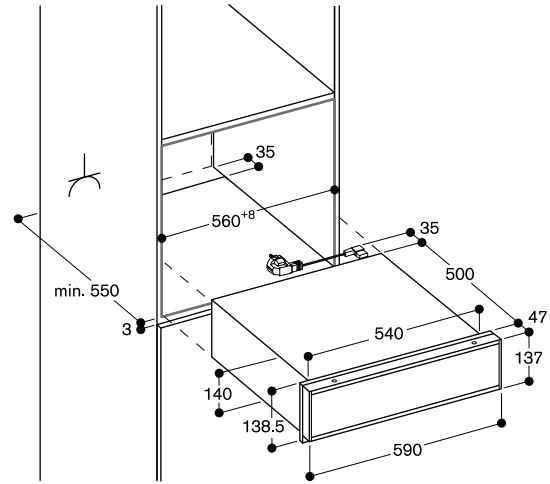

Side view of DV 461 below BS, BM, CM

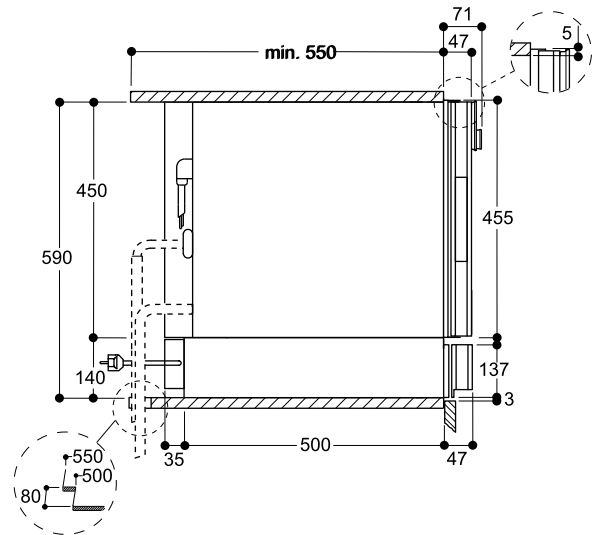

**DV 061 100***

Fully integrated
Width 60 cm, Height 14 cm

* Suitable for 400 and 200 series

Included in the price

50 vacuuming bags, small
50 vacuuming bags, big
1 raised vacuuming platform
1 adaptor f. vacuuming outside the chamber
1 vacuuming hose
1 adaptor for bottle plugs
3 plugs for vacuuming of bottles

Vacuating drawer 400 series**DV 061**

- Integrable in 14 cm high niche
- Hygienic stainless steel vacuuming chamber, applicable height up to 80 mm
- 3 vacuuming levels for vacuuming in the chamber, max. 99%
- 3 vacuuming levels for vacuuming outside the chamber, max. 90%
- Automatic connection recognition for vacuuming outside the chamber
- Cushioned closing system

Application

Vacuating for sous-vide cooking.
Vacuating for fast marinating and flavouring.
Vacuating for extended storage.
Vacuating of vacuuming containers outside the chamber.
Vacuating of liquids in bottles outside the chamber.

Handling

Touch key operation.

Features

Net volume 7 litres.
Capacity load max. 10 kg.
Maximum size of vacuuming bags
W 240 mm x L 350 mm.
3 heat-sealing levels for different strengths of bag material.
Sealing bar, non-stick coating, removable.
Safety glass cover, opens automatically after vacuuming.
Raised vacuuming platform, 44 mm, deployable.
Utility space in vacuuming chamber, W 210 mm x L 275 mm.
Membrane for avoiding reflow of liquids during vacuuming outside the chamber.
Drying programme for vacuuming pump.
Warning function.

Planning notes

Attention: To open the fully integrated variant, a handle or a recessed grip is required.
Front weight up to 3kg.
Installation of BS/BM/CM directly above DV in 59 cm niche without intermediate floor.
Built-in under worktop or in single niche.
The socket can be planned behind the appliance.

Special accessories

(order as spare parts):
Part No. 00578813
vacuuming bags, small
Part No. 00578814
vacuuming bags, big

Please read the installation details regarding oven combination on page 14 – 15.

Connection

Total connected load 0.32 kW.
Connection cable 1.5 m, pluggable.

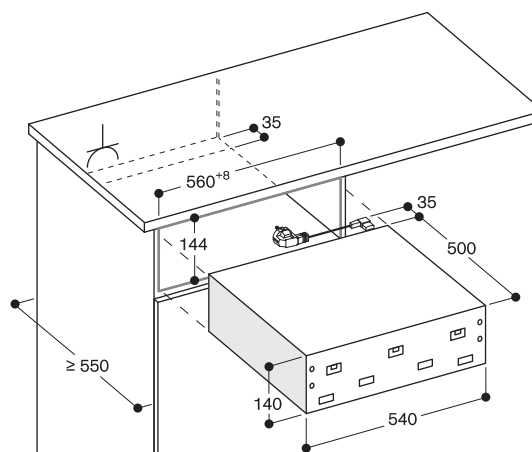

⚡ Socket

measurements in mm



WS 482 110

Stainless steel-backed glass front
Width 76 cm, Height 21 cm

Warming drawer 400 series WS 482

- Handleless drawer
- Bright interior light
- Cushioned closing system
- Hygienic stainless steel interior with glass bottom
- 4 power levels in the temperature range 40 °C to 80 °C (glass surface)
- Also for preparing and cooking meals, and for keeping meals warm

Heating methods

Defrosting of meals/proving of yeast dough.
Preheating of small beverage containers.
Keeping meals warm/slow cooking meals.
Warming ovenware.

Handling

Rotary knob operation.
Recessed grip at the front bottom of the drawer.

Features

Net volume 38 litres.
Volume capacity: Dinner service for 10 people including ø24 cm plates and soup bowls, additional bowls and a serving dish depending on size.
Max. load 25 kg.
Usable interior dimensions W 606 x H 132 x D 480 mm.
Heating under glass bottom for easy cleaning.
Fan for even heat distribution for fast warming ovenware.
Status display, visible in the glass front.
Glass bottom made of safety glass.

Planning notes

The panel surface of the appliance extends 47 mm from the furniture cavity.
Installation of BO/BS above WS with dimensionally stable intermediate shelf.
Installation of BS above WS in 66.5 cm niche with intermediate floor (gap of 7 mm between WS and BS).
The socket can be planned behind the appliance.

Please read the installation details regarding oven combination on page 14 – 15.

Connection

Total connected load 0.81 kW.
Connection cable 1.5 m, pluggable.

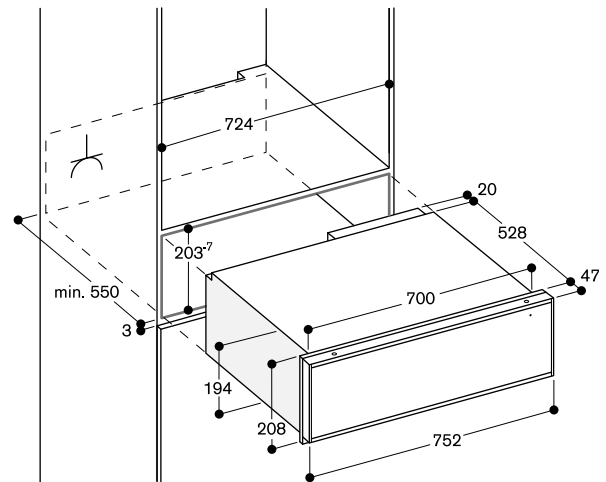

Side view of WS 482 below BO 480

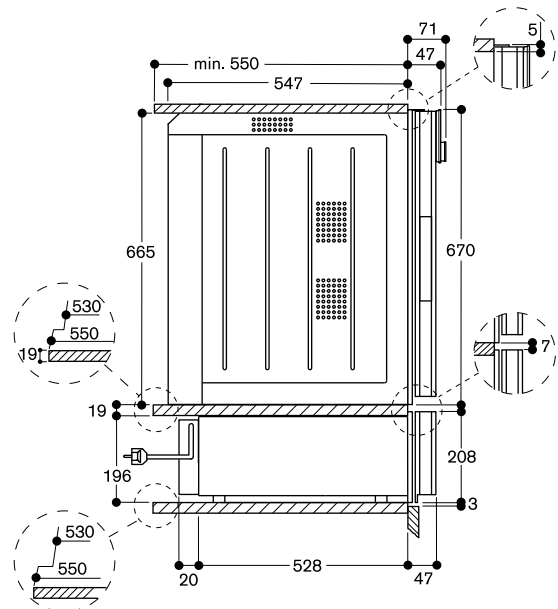

Side view of WS 482 below BS 484/485

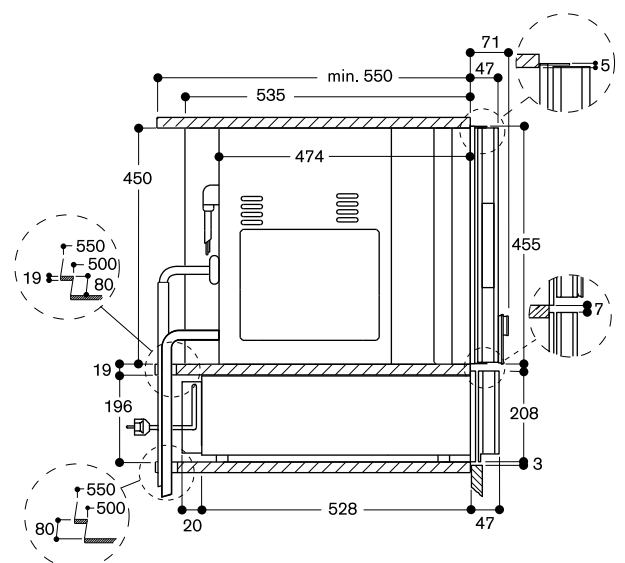

**WS 461 112**

Stainless steel-backed glass front
Width 60 cm, Height 14 cm

WS 461 102

Glass front in Gaggenau Anthracite
Width 60 cm, Height 14 cm

Culinary warming drawer 400 series WS 461

- Handleless drawer
- Cushioned closing system
- Hygienic stainless steel interior with glass bottom
- Direct temperature selection in the range 30 °C to 80 °C
- For slow cooking, dough proofing, herbs and fruits drying, chocolate melting and defrosting

Heating methods

Slow cooking.
Keeping meals warm.
Warming ovenware.
Cups and plates warming.
Direct temperature control.
Personalisation function via Home Connect.
16 additional programs via Home Connect.

Handling

Touch key operation.
Recessed grip at the front bottom of the drawer.

Features

Net volume 20 litres.
Volume capacity: Dinner service for 6 people including ø27 cm plates and soup bowls, additional bowls and a serving dish depending on size.
Capacity load max. 25 kg.
Usable interior dimensions W547 mm x H 91 mm x D 410 mm.
Heating system for even heat distribution and stable cavity temperature.
Status display, visible in the glass front.
Glass bottom made of safety glass.

Selected digital services (Home Connect)

Additional programmes and recipes.
Remote control and monitoring.
Timing function.

Please read additional information on Home Connect on page 411.

Planning notes

The panel surface of the appliance extends 47 mm from the furniture cavity.
Installation of BS/BM/CM directly above WS in 59 cm niche without intermediate floor.
The socket can be planned behind the appliance.

Please read the installation details regarding oven combination on page 14 – 15.

Connection

Total connected load 0.82 kW.
Connection cable 1.8m, pluggable.

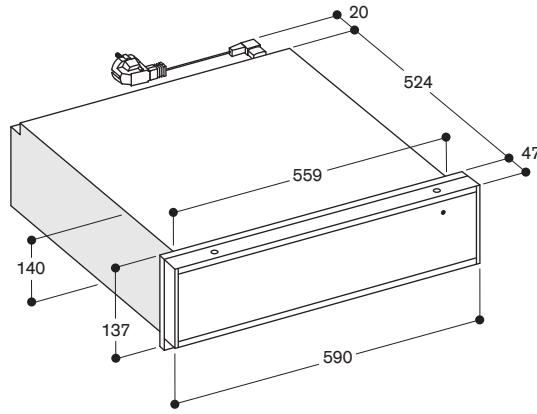

Measurements in mm

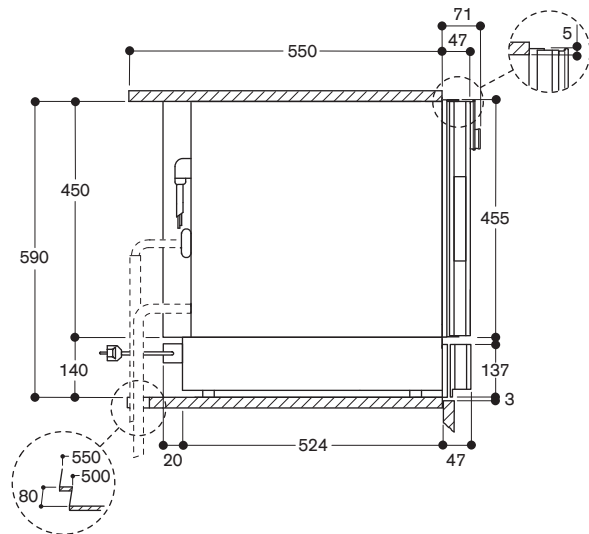
Side view of WS 461 below BS, BM, CM

Measurements in mm



WS 462 112

Stainless steel-backed glass front
Width 60 cm, Height 29 cm

WS 462 102

Glass front in Gaggenau Anthracite
Width 60 cm, Height 29 cm

Culinary warming drawer 400 series

WS 462

- Handleless drawer
- Cushioned closing system
- Hygienic stainless steel interior with glass bottom
- Direct temperature selection in the range 30 °C to 80 °C
- For slow cooking, dough proofing, herbs and fruits drying, chocolate melting and defrosting

Heating methods

Slow cooking.
Keeping meals warm.
Warming ovenware.
Cups and plates warming.
Direct temperature control.
Personalisation function via Home Connect.
16 additional programs via Home Connect.

Handling

Touch key operation.
Recessed grip at the front bottom of the drawer.

Features

Net volume 54 litres.
Volume capacity: Dinner service for 12 people including ø 27 cm plates and soup bowls, additional bowls and a serving dish depending on size.
Capacity load max. 25 kg.
Usable interior dimensions W 547 mm x H 241 mm x D 410 mm.
Heating system for even heat distribution and stable cavity temperature.
Status display, visible in the glass front.
Glass bottom made of safety glass.

Selected digital services

(Home Connect)

Additional programmes and recipes.
Remote control and monitoring.
Timing function.

Please read additional information on Home Connect on page 411.

Planning notes

The panel surface of the appliance extends 47 mm from the furniture cavity.
Installation of BS/BM/CM directly above WS in 59 cm niche without intermediate floor.
The socket can be planned behind the appliance.

Please read the installation details regarding oven combination on page 14 – 15.

Connection

Total connected load 0.82 kW.
Connection cable 1.8 m, pluggable.

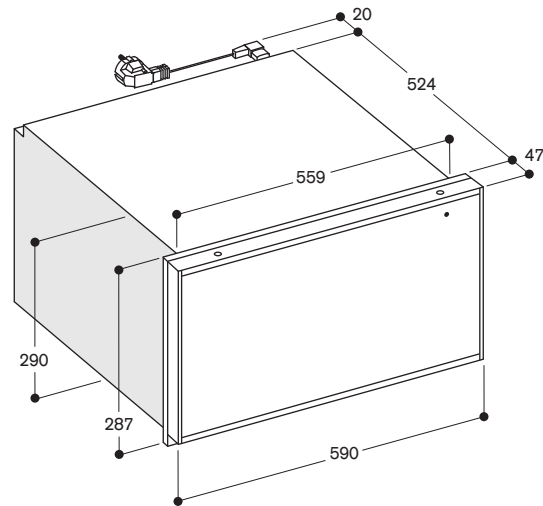

Side view of WS 462 below BO

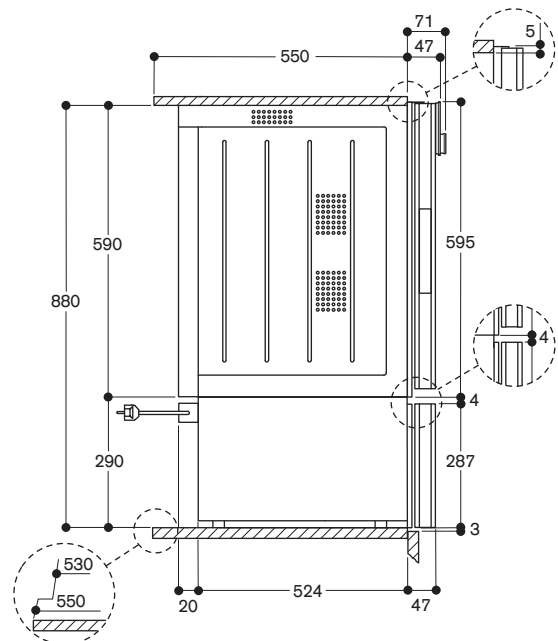

Measurements in mm

**WS 061 102***

Fully integrated
Hygienic stainless steel interior with
glass bottom
Width 60 cm, Height 14 cm

* Suitable for 400 and 200 series

Culinary warming drawer 400 series WS 061

- Direct temperature selection in the range 30 °C to 80 °C
- For slow cooking, dough proofing, herbs and fruits drying, chocolate melting and defrosting

Heating methods

Slow cooking.
Keeping meals warm.
Warming ovenware.
Cups and plates warming.
Direct temperature control.
Personalisation function via Home Connect.
16 additional programs via Home Connect.

Handling

Touch key operation.

Features

Net volume 20 litres.
Volume capacity: Dinner service for 6 people including ø 27 cm plates and soup bowls, additional bowls and a serving dish depending on size.
Capacity load max. 25 kg.
Usable interior dimensions
W 547 mm x H 91 mm x D 410 mm.
Heating system for even heat distribution and stable cavity temperature.
Status display, visible in the glass front.
Glass bottom made of safety glass.

**Selected digital services
(Home Connect)**

Additional programmes and recipes.
Remote control and monitoring.
Timing function.

Please read additional information on Home Connect on page 411.

Planning notes

Attention: To open the fully integrated variant, a handle or a recessed grip is necessary.
Front weight up to 3 kg.
The socket can be planned behind the appliance.

Please read the installation details regarding oven combination on page 14 – 15.

Connection

Total connected load 0.82 KW.
Connection cable 1.8 m, pluggable.

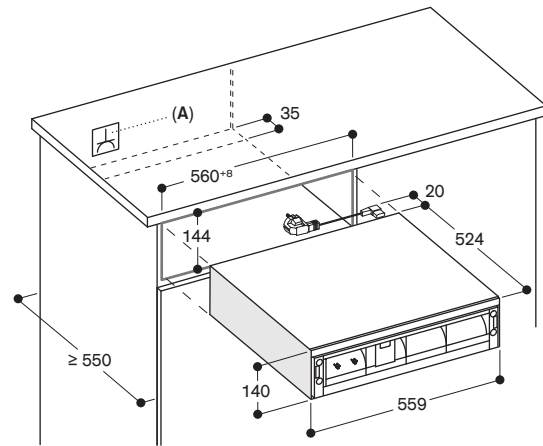

A: Socket

Measurements in mm

Accessories and special accessories 400 series

Advice: Not every illustrated accessory fits to every oven. For exact allocation see page 40 – 43.

BA 010 301

Triple telescopic pull-out rack
For combi-steam oven.

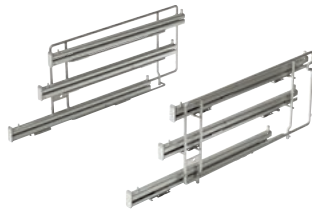

BA 016 105

Pull-out system
Fully extendable telescopic rails and
enamelled cast iron frame.



BA 018 105

Pull-out system
Fully extendable telescopic rails and
enamelled cast iron frame.

BA 020 361

Cooking container, stainless steel,
unperforated, 46 mm deep, 5.4l.



BA 020 370

Cooking container, stainless steel,
perforated, 40 mm deep, 5l.



BA 020 381

Cooking container, non-stick,
unperforated, 46 mm deep, 5.4l.



BA 020 390

Cooking container, non-stick,
perforated, 40 mm deep, 5l.

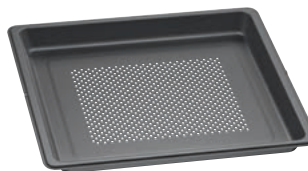

BA 026 115

Baking tray, enamelled
15 mm deep.

BA 028 115

Baking tray, enamelled
30 mm deep.



BA 036 105

Wire rack, chromium-plated
Without opening, with feet.

BA 038 105

Wire rack, chromium-plated
Without opening, with feet.

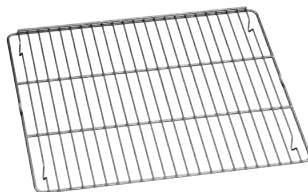

BA 046 117

Glass tray
24 mm deep.



BA 226 105

Grill tray, enamelled
30 mm deep.



BA 056 115

Heating element for baking stone and
Gastronorm roaster

BA 058 115

Heating element for baking stone and
Gastronorm roaster

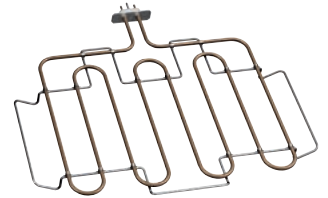

BA 056 133

Baking stone
Incl. baking stone support and pizza
paddle (heating element must be
ordered separately).
Not in combination with pull-out system.

BA 058 133

Baking stone
Incl. baking stone support and pizza
paddle (heating element must be
ordered separately).
Not in combination with pull-out system.



BS 020 002

Pizza paddle, set of 2



GN 010 330

Adapter for gastronorm insert and
roaster.

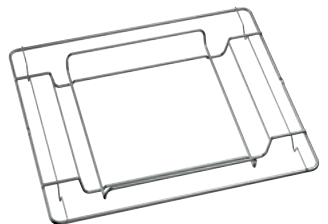

GN 114 130

Gastronorm insert, stainless steel,
GN 1/3
Unperforated, 40 mm deep, 1.5l.

**GN 114 230**

Gastronorm insert, stainless steel,
GN 2/3
Unperforated, 40 mm deep, 3l.

**GN 124 130**

Gastronorm insert, stainless steel,
GN 1/3
Perforated, 40 mm deep, 1.5l.

**GN 124 230**

Gastronorm insert, stainless steel,
GN 2/3
Perforated, 40 mm deep, 3l.

**GN 340 230**

Gastronorm roaster in cast aluminium
GN 2/3, height 165 mm, non-stick.
For roasting in oven with roasting
function.
Lower and upper part can also be
used as separate ovenproof dishes,
height 100 and 65 mm.
For ovens with heating element
BA 056 115 or BA 058 115 and
pull-out system BA 016 or BA 018
(both to be ordered separately) and
for Combi-steam ovens with adapter
GN 010 330 and pull-out system
BA 010 301 (both to be ordered
separately).

**CL S10 040**

Cleaning cartridges, set of 4.
For Combi-steam oven.

**GF 111 100**

Descaling and neutralising filter,
for first installation.
Descaling system, recommended to be
installed if water hardness exceeds
7 °dH or carbon hardness 5 °dH.
Filter head with integrated non-return
valve and filter.
Width 130 mm, Height 265 mm,
Depth 121 mm.
Water inlet 1.5 m with 3/4" connection.

**GF 121 110**

Filter cartridge

**GZ 010 011**

Extension for water inlet and outlet
(2 m long).



Accessories and special accessories 400 series



BX 480/BX 481

Baking tray, enamelled		Double oven
BA 026 115	15 mm deep	
BA 028 115	30 mm deep	• (2x)/°
Pull-out rack		
BA 016 105	Pull-out system with fully extendable telescopic pull-out rack and pyrolysis-safe cast frame	
BA 018 105	Pull-out system with fully extendable telescopic pull-out rack and pyrolysis-safe cast frame	°
BA 010 301	Triple telescopic pull-out rack for combi-steam oven	
Baking stone		
BA 056 133	incl. baking stone support and pizza paddle (heating element must be ordered separately)	
BA 058 133	incl. baking stone support and pizza paddle (heating element must be ordered separately)	°
Cooking container, steam oven		
BA 020 361	Cooking container, stainless steel, unperforated, 46 mm deep, 5.4 l	
BA 020 370	Cooking container, stainless steel, perforated, 40 mm deep, 5 l	
BA 020 381	Cooking container, non-stick, unperforated, 46 mm deep, 5.4 l	
BA 020 390	Cooking container, non-stick, perforated, 40 mm deep, 5 l	
GN 114 130	GN 1/3, unperforated, 40 mm deep, 1.5 l	
GN 114 230	GN 2/3, unperforated, 40 mm deep, 3 l	
GN 124 130	GN 1/3, perforated, 40 mm deep, 1.5 l	
GN 124 230	GN 2/3, perforated, 40 mm deep, 3 l	
Gastronorm roaster, cast aluminium		
GN 340 230	GN 2/3, height 165 mm, non-stick For ovens with heating element BA 056 115 or BA 058 115 and pull-out system BA 016 or BA 018 (both to be ordered separately) and for Combi-steam ovens with adapter GN 010 330 and pull-out system BA 010 301 (See also page 412)	°
GN-Adapter		
GN 010 330	Adapter for gastronorm insert	
Glass tray		
BA 046 117	24 mm deep	
Wire rack		
BA 036 105	no opening, with feet	
BA 038 105	no opening, with feet	• (2x)/°
Part No. 672921	for grill trays BA 226 105, with opening, and feet	
Part No. 706321	for grill tray ET-Nr. 687055, with opening and feet	• (2x)/°
Grill tray, enamelled		
BA 226 105	30 mm deep	
Part No. 687055	with feet and rotisserie spit attachment, 30 mm deep	• (2x)/°
Heating element		
BA 056 115	Necessary accessory for baking stone BA 056 133	
BA 058 115	Necessary accessory for baking stone BA 058 133	°
Pizza paddle		
BS 020 002	Set of 2	°
Bean container		
Part No. 11015223	Bean container with lid	
Cleaning and care		
CL S10 040	Cleaning cartridges, set of 4	
Part No. 17002490	Descaling tablets, for combi steam ovens, set of 4	
Part No. 17000705	Water filter cartridge	
Part No. 17000706	Water filter cartridge, set of 3	
Part No. is region-specific	Descaling tablets available via customer service	
Part No. is region-specific	Cleaning tablets available via customer service	
Water connection		
GF 111 100	Descaling and neutralising filter, for first installation	
GF 121 110	Filter cartridge for GF 111 100	
GZ 010 011	Extension for water inlet and outlet hose	
Vacuuming bags		
Part No. 00578813	Vacuuming bags, small	
Part No. 00578814	Vacuuming bags, big	

• Standard.

° Special accessory.

Accessories and special accessories 400 series



BM 484/BM 485

Combi-microwave oven

Baking tray, enamelled	
BA 026 115	15 mm deep
BA 028 115	30 mm deep
Pull-out rack	
BA 016 105	Pull-out system with fully extendable telescopic pull-out rack and pyrolysis-safe cast frame
BA 018 105	Pull-out system with fully extendable telescopic pull-out rack and pyrolysis-safe cast frame
BA 010 301	Triple telescopic pull-out rack for combi-steam oven
Baking stone	
BA 056 133	incl. baking stone support and pizza paddle (heating element must be ordered separately)
BA 058 133	incl. baking stone support and pizza paddle (heating element must be ordered separately)
Cooking container, steam oven	
BA 020 361	Cooking container, stainless steel, unperforated, 46 mm deep, 5.4 l
BA 020 370	Cooking container, stainless steel, perforated, 40 mm deep, 5 l
BA 020 381	Cooking container, non-stick, unperforated, 46 mm deep, 5.4 l
BA 020 390	Cooking container, non-stick, perforated, 40 mm deep, 5 l
GN 114 130	GN 1/3, unperforated, 40 mm deep, 1.5 l
GN 114 230	GN 2/3, unperforated, 40 mm deep, 3 l
GN 124 130	GN 1/3, perforated, 40 mm deep, 1.5 l
GN 124 230	GN 2/3, perforated, 40 mm deep, 3 l
Gastronorm roaster, cast aluminium	
GN 340 230	GN 2/3, height 165 mm, non-stick For ovens with heating element BA 056 115 or BA 058 115 and pull-out system BA 016 or BA 018 (both to be ordered separately) and for Combi-steam ovens with adapter GN 010 330 and pull-out system BA 010 301 (See also page 412)
GN-Adapter	
GN 010 330	Adapter for gastronorm insert
Glass tray	
BA 046 117	24 mm deep
Wire rack	
BA 036 105	no opening, with feet
BA 038 105	no opening, with feet
Part No. 672921	for grill trays BA 226 105, with opening, and feet
Part No. 706321	for grill tray ET-Nr. 687055, with opening and feet
Grill tray, enamelled	
BA 226 105	30 mm deep
Part No. 687055	with feet and rotisserie spit attachment, 30 mm deep
Heating element	
BA 056 115	Necessary accessory for baking stone BA 056 133
BA 058 115	Necessary accessory for baking stone BA 058 133
Pizza paddle	
BS 020 002	Set of 2
Bean container	
Part No. 11015223	Bean container with lid
Cleaning and care	
CL S10 040	Cleaning cartridges, set of 4
Part No. 17002490	Descaling tablets, for combi steam ovens, set of 4
Part No. 17000705	Water filter cartridge
Part No. 17000706	Water filter cartridge, set of 3
Part No. is region-specific	Descaling tablets available via customer service
Part No. is region-specific	Cleaning tablets available via customer service
Water connection	
GF 111 100	Descaling and neutralising filter, for first installation
GF 121 110	Filter cartridge for GF 111 100
GZ 010 011	Extension for water inlet and outlet hose
Vacuuming bags	
Part No. 00578813	Vacuuming bags, small
Part No. 00578814	Vacuuming bags, big

• Standard.

◦ Special accessory.



BM 450/BM 451
BM 454/BM 455

Combi-microwave oven



CM450

Fully automatic
espresso machine



DV 461
DV 061

Vacuuming drawer



WS 482

Warming drawer



WS 461

Culinary warming
drawer



WS 462

Culinary warming
drawer

•/°

-
-
-
-

- /°
- /°

Ovens 400 series



Appliance type		Double oven	Oven
Side-opening door right-hinged / left-hinged		BX 480/BX 481	BO 480/BO 481
Stainless steel-backed full glass door		BX 480/481 112	BO 480/481 112
Full glass door in Gaggenau Anthracite			
Dimensions			
Width	(cm)	76	76
Appliance dimensions W x H x D ¹	(mm)	752 x 1.428 x 547	752 x 670 x 547
Door panel extension from furniture cavity	(mm)	47	47
Niche dimensions W x H x D	(mm)	724 x 1.425 x 550	724 x 665 x 550
Net weight	(kg)	152	77
Volume / energy efficiency (to EU regulations EN 60350-1, 65/2014 and 66/2014)			
Net volume	(l)	110 per cooking compartment	110
Number of cooking compartments		2	1
Interior dimensions W x H x D	(mm)	624 x 435 x 403	624 x 435 x 403
Energy efficiency class with eco hot air		A * per cooking compartment	A *
Energy Efficiency Index (EEI)		96 above, 121 below	96
Energy consumption with top / bottom heat	(kWh)	1.53 per cooking compartment	1.53
Energy consumption with eco hot air	(kWh)	0.97 above, 1.22 below	0.97
Heat source		electric	electric
Heating methods			
Temperature range	(°C)	30–300	30–300
Hot air / Eco hot air / top + bottom heat		•/•/•	•/•/•
Top heat / bottom heat / hot air + bottom heat		•/•/•	•/•/•
Top + 1/3 bottom heat		•	•
1/3 top + bottom heat		•	•
Hot air + 1/3 bottom heat		•	•
Full surface grill + circulated air		•	•
Full surface grill		•	•
Compact grill		•	•
Baking stone function		•	•
Roaster function		•	•
Dough proofing / defrosting / keeping warm		•/•/•	•/•/•
Handling			
TFT touch display		•	•
Controls at the top / centered / at the bottom		- / • / -	• / - / -
Automatic door opening		-	•
Clear text display	(No. of languages)	25	44
Individual recipes		-	50
Door opening angle	(°)	180	180
Features			
Electronic temperature control		•	•
Three-Point core temperature probe		• (bottom only)	•
Automatic programmes		-	•
Rotisserie spit		• (bottom only)	•
Baking stone socket		•	•
Roasting function		•	•
Actual temperature display		•	•
Rapid heating		•	•
Cooking time, cooking time end, timer, stopwatch		•	•
Long-term timer		•	•
Halogen light on the top	(W)	60 per cooking compartment	60
Halogen light on the side	(W)	10 per cooking compartment	2 x 10
Tray levels	(No.)	5	5
Digital services (Home Connect) either via LAN or wireless via WiFi ³		-	• ³
Accessories			
Enamelled baking tray		1 per cooking compartment	1
Size of largest baking tray	(cm ²)	1.780	1.780
Wire rack		1 per cooking compartment	1
Enamelled grill tray / wire rack for grill tray		1/1 per cooking compartment	1/1
Glass tray		-	-
Safety			
Thermally insulated door with multiple glazing		4-fold	4-fold
Child lock / door lock / safety shut-off		• / - / •	• / • / •
Cooled housing with temperature protection		•	•
Cleaning			
Pyrolytic system		•	•
Gaggenau enamel		•	•
Heated air cleaning catalyser		•	•
Connection			
Total connected load	(kW)	9.2	5.52

• Standard. – Not available.

¹ Appliance depth: the immersion depth of the appliance in the niche. ² Special accessory, see pages 38–43.

³ The use of the Home Connect functionality depends on the Home Connect services, which are not available in every country.

* Energy efficiency class: at a range of energy efficiency classes from A+++ to D.



Oven	Oven	Oven
BO 470/BO 471	BO 450/BO 451	BO 420/BO 421
BO 470/471 112	BO 450/451 112	BO 420/421 112
BO 470/471 102	BO 420/421 102	
60	60	60
590 x 595 x 547	590 x 595 x 547	590 x 595 x 547
47	47	47
560 x 590 x 550	560 x 590 x 550	560 x 590 x 550
64	56	56
76	76	76
1	1	1
475 x 383 x 414	475 x 383 x 414	475 x 383 x 414
A	A	A
96	96	96
1.25	1.25	1.25
0.83	0.83	0.83
electric	electric	electric
30-300	30-300	50 - 300
•/•/•	•/•/•	•/•/•
•/•/•	•/•/•	•/•/•
•	-	-
•	-	-
•	-	-
•	•	•
•	•	-
•	•	•
•	•	-
•/•/•	•/•/-	-/-/-
•	•	•
•/-/-	•/-/-	•/-/-
•	•	•
44	44	44
50	50	50
180	180	180
•	•	•
•	•	-
•	•	-
•	-	-
•	•	•
•	•	-
•	•	•
•	•	•
•	•	•
•	•	•
60	60	60
2 x 10	10	-
4	4	4
• ³	• ³	• ³
2	1	1
1.200	1.200	1.200
1	1	1
1/1	BA 226 105 ² /672 921 ²	BA 226 105 ² /672 921 ²
1	1	1
4-fold	4-fold	4-fold
•/•/•	•/•/•	•/•/•
•	•	•
•	•	•
•	•	•
3.7	3.7	3.7

Combi-steam ovens 400 series



Appliance type	Combi-steam oven	Combi-steam oven
Side-opening door right-hinged / left-hinged	BS 484/BS 485	BS 470/BS 471
Stainless steel-backed full glass door	BS 484/BS 485 112	BS 470/BS 471 112
Full glass door in Gaggenau Anthracite		BS 470/BS 471 102
Dimensions		
Width	(cm) 76	60
Appliance dimensions W x H x D ¹	(mm) 752 x 455 x 540	590 x 455 x 540
Door panel extension from furniture cavity	(mm) 47	47
Niche dimensions W x H x D	(mm) 724 x 450 x 550	560 x 450 x 550
Net weight	(kg) 53	47
Volume / energy efficiency (to EU regulations EN 60350-1, 65/2014 and 66/2014)		
Net volume	(l) 50	50
Number of cooking compartments	1	1
Interior dimensions W x H x D	(mm) 501 x 246 x 406	501 x 246 x 406
Energy efficiency class with hot air + 30 % humidity	A *	A *
Energy Efficiency Index (EEI)	94.7	94.7
Energy consumption with hot air + 30 % humidity	(kWh) 0.72	0.72
Heat source	(min) electric	electric
Heating methods		
Temperature range	(°C) 30–230	30–230
Hot air + 100 % humidity	•	•
Hot air + 80 % humidity	•	•
Hot air + 60 % humidity	•	•
Hot air + 30 % humidity	•	•
Hot air + 0 % humidity	•	•
Low temperature cooking	•	•
Sous-vide cooking	•	•
Full surface grill level 1 + humidity	•	•
Full surface grill level 2 + humidity	•	•
Full surface grill + circulated air	•	•
Dough proofing	•	•
Defrosting	•	•
Regenerating	•	•
Handling		
TFT touch display	•	•
Controls at the top / at the bottom	- / •	• / -
Automatic door opening	•	•
Clear text display	(No. of languages) 44	44
Individual recipes	50	50
Door opening angle	(°) 180°	180°
Features		
Steaming without pressure	•	•
Electronic temperature control	•	•
Full surface grill behind glass ceramic	(W) 2,000	2,000
Steam removal / misting	• / •	• / •
Three-Point core temperature probe	•	•
Automatic programmes	•	•
Actual temperature display	•	•
Cooking time, cooking time end, timer, stopwatch	•	•
Long-term timer	•	•
Automatic boiling point detection	•	•
Capacity display for filter cartridge	•	•
Water tank capacity / water level warning	(l) - / -	- / -
LED light on the side	(W) 2 x 10	2 x 10
Tray levels / stainless steel cooking interior	(No.) 3 / •	3 / •
Digital services (Home Connect) either via LAN or wireless via WiFi. ³	•	•
Accessories		
Size of largest baking tray	(cm ²) 810	810
Wire rack	1	1
Cooking container, stainless steel, 40 mm, perforated / unperforated	1/1	1/1
Cleaning cartridge	4	4
Descaling tablets	Part No. 17002490	Part No. 17002490
Safety		
Thermally insulated door with multiple glazing	3-fold	3-fold
Child lock / door lock / safety shut-off	• / • / •	• / • / •
Cooled housing with temperature protection	•	•
Cleaning		
Cleaning programme	•	•
Descaling programme / drying programme	• / •	• / •
Automatic drying of the cavity at the end of the cooking process.	•	•
Connection		
Total connected load	(kW) 3.15	3.15
Fixed inlet and outlet water connection	•	•

• Standard. – Not available.

¹ Appliance depth: the immersion depth of the appliance in the niche. ² Special accessory, see pages 38 – 43.

³ The use of the Home Connect functionality depends on the Home Connect services, which are not available in every country.

* Energy efficiency class: at a range of energy efficiency classes from A+++ to D.



Combi-steam oven

Combi-steam oven

Combi-steam oven

BS 474/BS 475
BS 474/BS 475 112
BS 474/BS 475 102

BS 450/BS 451
BS 450/BS 451 111
BS 450/BS 451 101

BS 454/BS 455
BS 454/BS 455 111
BS 454/BS 455 101

60
590 x 455 x 540
47
560 x 450 x 550
47

60
590 x 455 x 540
47
560 x 450 x 550
47

60
590 x 455 x 540
47
560 x 450 x 550
47

50
1
501 x 246 x 406

50
1
501 x 246 x 406

50
1
501 x 246 x 406



94.7
0.72
electric

94.7
0.60
electric

94.7
0.60
electric

30-230
•
•
•
•
•
•
•
•
•
•
•
•
•
•
•
•
•
•
•
•

30-230
•
•
•
•
•
•
•
•
•
•
•
•
•
•
•
•
•
•
•
•
•

30-230
•
•
•
•
•
•
•
•
•
•
•
•
•
•
•
•
•
•
•
•
•

•
- / •
•
44
50
180°

•
• / -
•
44
50
180°

•
- / •
•
44
50
180°

•
•
2.000
• / •
•
•
•
•
•
•
•
- / -
2 x 10
3 / •
•

•
•
-
- / •
•
•
•
•
•
•
-
1.7 / •
2 x 10
3 / •
•

•
•
-
- / •
•
•
•
•
•
•
-
1.7 / •
2 x 10
3 / •
•

810
1
1/1
4
Part No. 17002490

810
1
1/1
4
Part No. 17002490

810
1
1/1
4
Part No. 17002490

3-fold
• / • / •
•

3-fold
• / • / •
•

3-fold
• / • / •
•

•
• / •
•

•
• / •
•

•
• / •
•

3.15
•

3.15
-

3.15
-

Combi-microwave ovens 400 series



Appliance type		Combi-microwave oven	Combi-microwave oven	Combi-microwave oven
Side-opening door right-hinged / left-hinged		BM 484/BM 485	BM 450/BM 451	BM 454/BM 455
Stainless steel-backed full glass door		BM 484/485 110	BM 450/451 110	BM 454/455 110
Full glass door in Gaggenau Anthracite			BM 450/451 100	BM 454/455 100
Dimensions				
Width	(cm)	76	60	60
Appliance dimensions W x H x D ¹	(mm)	752 x 455 x 535	590 x 455 x 535	590 x 455 x 535
Door panel extension from furniture cavity	(mm)	47	47	47
Niche dimensions W x H x D	(mm)	724 x 450 x 550	560 x 450 x 550	560 x 450 x 550
Net weight	(kg)	50	46	46
Volumen				
Capacity	(l)	36	36	36
Interior dimensions W x H x D	(mm)	445 x 236 x 348	445 x 236 x 348	445 x 236 x 348
Heating methods / Programmes				
Maximum microwave output	(W)	1.000	1.000	1.000
Microwave output levels	(No.)	5	5	5
Hot air with temperature range	(°C)	40, 100–250	40, 100–250	40, 100–250
Full surface grill + hot air with temperature range	(°C)	100–250	100–250	100–250
Full surface grill + circulated air with temperature range	(°C)	100–250	100–250	100–250
Full surface grill as quartz grill with levels of intensity	(No.)	3	3	3
Maximum grill output	(W)	2.000	2.000	2.000
Maximum Hot air output	(W)	1.950	1.950	1.950
Maximum microwave output for combination with grill and oven	(W)	600	600	600
Sequential operation of up to 5 modes incl. programming of combined operation and rest time		•	•	•
Automatic weight feature	(No.)	15	15	15
Handling				
TFT touch display		•	•	•
Controls at the top / at the bottom		•/–	•/–	–/•
Automatic door opening		•	•	•
Clear text display	(No. of languages)	25	25	25
Individual recipes		50	50	50
Door opening angle		180°	180°	180°
Features				
Electronic temperature control		•	•	•
Actual temperature display		•	•	•
Rapid heating		•	•	•
Innowave		•	•	•
Cooking time, switch-off time, short-term timer, stop watch		•/•/•/•	•/•/•/•	•/•/•/•
Long-term timer		•	•	•
Interior lighting, side	(W)	60	60	60
Rack levels	(No.)	4	4	4
Accessories				
Glass tray		•	•	•
Wire rack		•	•	•
Glass rod		•	•	•
Safety				
Thermally insulated door with multiple glazing		•	•	•
Child lock / safety shut-off		•/•	•/•	•/•
Triple door lock		•	•	•
Cooled housing with temperature protection		•	•	•
Cleaning				
Catalytic special enamelling at interior back wall		•	•	•
Stainless steel interior with ceramic base.		•	•	•
Connection				
Total connected load	(kW)	3.1	3.1	3.1

• Standard. – Not available.

¹ Appliance depth: the immersion depth of the appliance in the niche.



Appliance type		Fully automatic espresso machine
Stainless steel-backed glass front		CM 450 112
Full glass door in Gaggenau Anthracite		CM 450 102
Dimensions		
Width	(cm)	60
Appliance dimensions W x H x D ¹	(mm)	590 x 455 x 444
Door panel extension from furniture cavity	(mm)	47
Niche dimensions W x H x D	(mm)	560 x 450 x 550
Net weight	(kg)	22
Typ of beverage		
		Ristretto / 2 x Ristretto
		Espresso / 2 x Espresso
		Espresso Macchiato / 2 x Espresso Macchiato
		Coffee / 2 x coffee
		Americano / 2 x Americano
		Caffe Latte / 2 x Caffe Latte
		Latte Macchiato / 2 x Latte Macchiato
		Cappuccino / 2 x Cappuccino
		Flat White / 2 x Flat White
		Milk froth / 2 x Milk froth
		Warm milk / 2 x Warm milk
		Hot water / 2 x Hot water
Handling		
TFT touch display		•
Controls at the top		•
Automatic door opening		•
Clear text display	(No. of languages)	25
Beverages can be personalised and memorised	(No.)	8
Beverage size settings	(No.)	3
Coffee strength levels	(No.)	8
Coffee temperature levels	(No.)	3
Hot water temperature levels	(°C)	10
Coffee-milk ratio levels		•
Height adjustable coffee dispenser up to	(cm)	15
Programmable basic settings		
- Lighting scenarios	(No.)	7
- Capacity unit	(ml/fl.oz.)	•
- Adjustability of dispensing per type and size of beverage to match the cup size		•
- Standby after	(min, h)	5 min to 12 h
- Water hardness	(No. of levels)	4, water-softening system
- Water filter		•
Features		
Aroma brewing technology		•
Grinding unit with ceramic discs		•
Automatic adjustment of ground coffee quantity		•
Continuous flow heater		•
Pump pressure	(bar)	19
Integrated milk system		•
Insulated milk container	(l)	0.5
Bean container	(g)	500
Separate container for second ground coffee type		•
Grinding level control		•
Volume of adjustable brewing chamber	(g)	8 to 12
Double grinding and brewing cycles for extra intensity for one beverage		•
Double grinding and brewing cycles for two beverages		•
Removable water tank	(l)	2.4
Water filter cartridge for water tank		1
Single portion cleaning		•
Electronic water filter exchange indicator		•
Electronic fill level control for milk, water and coffee beans		•
Electronic fill level control for drip tray and coffee residues container		•
Integrated LED lighting		•
Safety		
Child lock		•
Cleaning		
Fully automatic rinse programme when switching on/off		•/•
Automatic quick rinsing of milk system		•
Automatic cleaning and descaling programme		•
Automatic cleaning programme		•
Automatic descaling programme		•
Removable brewing unit		•
Coffee residue container and drip tray removable and dishwasher-safe		•
Beverage dispenser removable and dishwasher-safe		•
Emptying programme to prepare the appliance for holiday or transportation		•
Empty-grinding function, if using a new type of beans		•
Connection		
Total connected load	(kW)	1.6

• Standard. – Not available.

¹ Appliance depth: the immersion depth of the appliance in the niche.

Vacuuming drawer 400 series



Appliance type		Vacuuming drawer
Stainless steel-backed glass front		DV 461 110
Glass front in Gaggenau Anthracite		DV 461 100
Fully integrated		DV 061 100
Dimensions		
Width	(cm)	60
Appliance dimensions W x H x D ¹	(mm)	590 x 140 x 532
Door panel extension from furniture cavity	(mm)	47
Niche dimensions W x H x D	(mm)	560 x 140 x 550
Net weight	(kg)	31
Volume		
Net volume	(l)	7
Interior dimensions W x H x D	(mm)	210 x 95 x 275
Maximum size of vacuuming bags W x L	(mm)	240 x 350
Usage		
Vacuuming levels		3, max. 99 %
Heat-sealing levels		3
Vacuuming of bags and containers		•
Vacuuming of vacuuming containers and bottles		•
Vacuuming of liquids		•
Drying program for vacuuming pump		•
Warming function		•
Handling		
Sensor Control		•
Handleless drawer		•
Recessed grip		•
Push-to-open system		–
Cushioned closing system		•
Features		
Stainless steel vacuuming chamber		•
Maximum load	(kg)	10
Applicable height	(mm)	80
Safety glass cover		•
Sealing bar, non-stick, removable		•
Raised vacuuming platform		•
Connection with tube for vacuuming outside the chamber		•
Utility space in vacuuming chamber, W x L	(mm)	210 x 275
Membrane avoiding reflow of liquids during external vacuuming		•
Vacuuming bags, small, 180 mm x 280 mm	(pcs.)	50
Vacuuming bags, large, 240 mm x 350 mm	(pcs.)	50
Plug for vacuuming bottles	(pcs.)	3
Adaptor for bottle plugs		•
Connection		
Total connected load	(kW)	0.32

• Standard. – Not available.

¹ Appliance depth: the immersion depth of the appliance in the niche.



Appliance type		Warming drawer	Culinary warming drawer	Culinary warming drawer	Culinary warming drawer
Stainless steel-backed glass front		WS 482 110	WS 461 112	WS 462 112	
Glass front in Gaggenau Anthracite			WS 461 102	WS 462 102	
Fully integrated					WS 061 102
Dimensions					
Width	(cm)	76	60	60	60
Appliance dimensions W x H x D ¹	(mm)	752 x 208 x 548	590 x 140 x 524	590 x 290 x 524	590 x 140 x 524
Door panel extension from furniture cavity	(mm)	47	47	47	47
Niche dimensions W x H x D	(mm)	724 x 203 x 550	560 x 140 x 550	560 x 290 x 550	560 x 140 x 550
Net weight	(kg)	29	18	23	17
Volume					
Net volume	(l)	38	20	54	20
Interior dimensions W x H x D	(mm)	606 x 132 x 480	547 x 91 x 410	547 x 241 x 410	547 x 91 x 410
Number of table settings	(No.)	10	6	12	6
Heating methods					
Defrosting of meals / proving of yeast dough		•	•	•	•
Preheating of small beverage containers		•	•	•	•
Keeping meals warm / slow cooking meals		•	•	•	•
Warming ovenware		•	•	•	•
Low temperature cooking		•	•	•	•
Temperature range 30°C to 80°C	(temperature levels)	40 - 80°C	6	6	6
Further heating methods via App		–	•	•	•
Handling					
Touch key operation		–	•	•	•
Status display, visible in the glass front		•	•	•	•
Time setting via App		–	•	•	•
Handleless drawer		•	•	•	•
Recessed grip		•	•	•	•
Cushioned closing system		•	•	•	•
Home Connect		–	•	•	•
Features					
Interior light		•	–	–	–
Maximum load	(kg)	25	25	25	25
Stainless steel interior with glass bottom		•	•	•	•
Fan for even heat distribution		•	•	•	•
Connection					
Total connected load	(kW)	0.81	0.82	0.82	0.82

• Standard. – Not available.

¹ Appliance depth: the immersion depth of the appliance in the niche.



The ovens 200 series

Checklist for appliance combinations 200 series	54
Ovens 200 series	56
Combi-steam ovens 200 series	60
Steam ovens 200 series	66
Combi-microwave ovens 200 series	68
Microwave ovens 200 series	70
Fully automatic espresso machines 200 series	72
Vacuuming drawers 200 series	74
Warming drawers 200 series	75
Accessories special accessories 200 series	78
Technical specifications 200 series	82

Checklist for appliance combinations 200 series

This checklist provides the most relevant parameters for the perfect combination and ordering of ovens, Combi-steam ovens, steam ovens, Combi-microwave ovens, microwaves, fully automatic espresso machines, warming drawers and dishwashers.

When several appliances are listed (BSP/BMP), the first appliance is shown.

Vertical combinations

When planning and ordering please note that

- The door hinges of the appliances must be on the same side.
- The door hinge (right-/left-hinged) is not reversible.
- No further appliances may be fitted above the BSP.
- Only appliances with controls at the top can be installed above a dishwasher. The niche for appliances that are installed above it must be 56 cm wide. The dishwasher is 60 cm wide.

Horizontal combinations

When planning and ordering please note that

- The door hinges can be located on either the inside or outside, without the full door opening angle being restricted.
- The door hinge (right-/left-hinged) cannot be reversed retrospectively.
- A minimum clearance of 10 mm between the two doors must be observed.
- Combi-steam ovens, steam ovens, Combi-microwave ovens, microwaves and fully automatic espresso machines in combination with a warming drawer (14 cm in height) have the same total height as a 60 cm wide ovens.

BOP Ovens
 BSP Combi-steam ovens/steam ovens
 BMP Combi-microwave ovens/
 microwaves
 CMP Fully automatic espresso
 machine
 WSP Warming drawers
 DF Dishwashers

Please read additional planning notes on page 14 – 15.

All appliances shown can be obtained in these appliance colors:



Gaggenau Anthracite



Gaggenau Metallic



Gaggenau Silver

Vertical combination, 60 cm wide appliances



• BSP 2.0/BMP 250
 • BOP 2.0
 • WSP 222



• BMP 224
 • BOP 2.0
 • WSP 222



• BSP 2.0/BMP 250
 • BMP 250
 • WSP 221



• BMP 250/BSP 2.0
 • CMP 250
 • WSP 221



• BMP 224
 • CMP 250
 • WSP 221



• BOP 2.0
 • DF



• BSP 2.0/BMP 250
 • DF



• CMP 250
 • DF

Horizontal combination, 60 cm wide appliances



• BOP 2.1 • BOP 2.0



• BOP 2.1 • BSP 2.0/BMP 250
• DVP 221/WSP 221



• BOP 251 • CMP 250
• WSP 221/DVP 221



• BMP 251/BSP 2.1 • BMP 250/BSP 2.0
• WSP 221/DVP 221 • DVP 221/WSP 221



• BMP 251/BSP 2.1 • CMP 250
• DVP 221/WSP 221 • WSP 221/DVP 221



• BOP 251 • CMP 250 • BMP 250/BSP 2.0
• WSP 221/DVP 221 • DVP 221/WSP 221



• BMP 251/BSP 2.1 • CMP 250 • BMP 250/BSP 2.0
• WSP 221/DVP 221 • DVP 221/WSP 221 • WSP 221/DVP 221

Combination of 4 with warming drawer, 60 cm wide appliances



• BOP 2.1 • BMP 250/BSP 2.0 • BMP 250/BSP 2.0
• DVP 221/WSP 221 • WSP 221/DVP 221



• BMP 251/BSP 2.1 • BMP 250/BSP 2.0
• BOP 2.1 • CMP 250
• WSP 221/DVP 221



Controls at the top

Right-hinged

BOP 250 102

Full glass door in Gaggenau Anthracite
Width 60 cm

BOP 250 112

Full glass door in Gaggenau Metallic
Width 60 cm

BOP 250 132

Full glass door in Gaggenau Silver
Width 60 cm

Left-hinged

BOP 251 102

Full glass door in Gaggenau Anthracite
Width 60 cm

BOP 251 112

Full glass door in Gaggenau Metallic
Width 60 cm

BOP 251 132

Full glass door in Gaggenau Silver
Width 60 cm



Included in the price

- 1 baking tray, enamelled pyrolysis-safe
- 1 glass tray
- 1 wire rack
- 1 plug-in core temperature probe

Special accessories

BA 016 105

Pull-out system
Fully extendable telescopic rails and enamelled cast iron frame.

BA 026 115

Baking tray, enamelled
15 mm deep.

BA 036 105

Wire rack, chromium-plated
Without opening, with feet.

BA 046 117

Glass tray
24 mm deep.

BA 056 115

Heating element for baking stone and
Gastronorm roaster.

BA 056 133

Baking stone.
Incl. baking stone support and pizza
paddle (heating element must be
ordered separately).

Not in combination with pull-out
system.

BA 226 105

Grill tray, enamelled
30 mm deep.

BS 020 002

Pizza paddle, set of 2.

GN 340 230

Gastronorm roaster in cast aluminium.
GN2/3, height 165 mm, non-stick.

Oven 200 series

BOP 250/BOP 251

- Flush installation
- Pyrolytic system
- 13 heating methods with core temperature probe and baking stone function
- Automatic programmes
- Core temperature probe with estimation of cooking time
- TFT touch display
- Panel-free appliance with surface control module
- Electronic temperature control from 30 °C to 300 °C
- Net volume 76 litres

Heating methods

Hot air.
Eco hot air.
Top + bottom heat.
Top heat.
Bottom heat.
Hot air + bottom heat.
Full surface grill + circulated air.
Full surface grill.
Compact grill.
Baking stone function.
Roaster function.
Dough proofing.
Defrosting.

Handling

Rotary knob and TFT touch display operation.
Clear text display.
Option to save individual recipes (incl. core temperature probe).
Personalisation of automatic programmes.
Information key with use indicators.
Side-opening door opens up to 110° angle.

Features

Three-point core temperature probe with automatic shut-off and estimation of cooking time.
Automatic programmes.
Baking stone socket.
Actual temperature display.
Rapid heating.
Timer functions: cooking time, cooking time end, timer, stopwatch, long-term timer (certified by Star-K).
60 W halogen light on the top.
Enamelled side shelf supports with 4 tray levels, pyrolysis-safe.

Selected digital services (Home Connect)

Automatic programmes.
Remote monitoring and control.
Recipes.

Please read additional information on Home Connect on page 411.

Safety

Thermally insulated door with quintuple glazing.
Child lock.
Safety shut-off.
Cooled housing with temperature protection.

Cleaning

Pyrolytic system.
Gaggenau enamel.
Heated catalyser to clean the oven air.

Planning notes

Door hinge not reversible.
The door panel surface of the appliance extends 21 mm from the furniture cavity. The outer edge of the door handle extends 72 mm from the furniture cavity. Necessary lateral gap between appliance door and furniture panel of min. 5 mm.
Consider the overhang, incl. the door handle, when planning to open drawers next to the appliance.
When planning a corner solution, pay attention to the side-opening door and the minimum required distance to the wall.
For installation underneath cooktops: Distance between the underside of the cooktop and the top edge of the oven cavity: min. 15 mm. The planning notes for the cooktops (particularly regarding ventilation, gas/electric connection) must be taken into account.
To achieve the 550 mm installation depth, the connection cable needs to follow the slanted edge on the corner of the housing.
The mains socket needs to be planned outside the built-in niche.
The LAN port can be found at the back on the upper right side.

Please read the installation details regarding oven combination on page 14 – 15.

Connection

Energy efficiency class A at a range of energy efficiency classes from A+++ to D.
Total connected load 3.7 kW.
Plan a connection cable.
Plan a LAN cable.

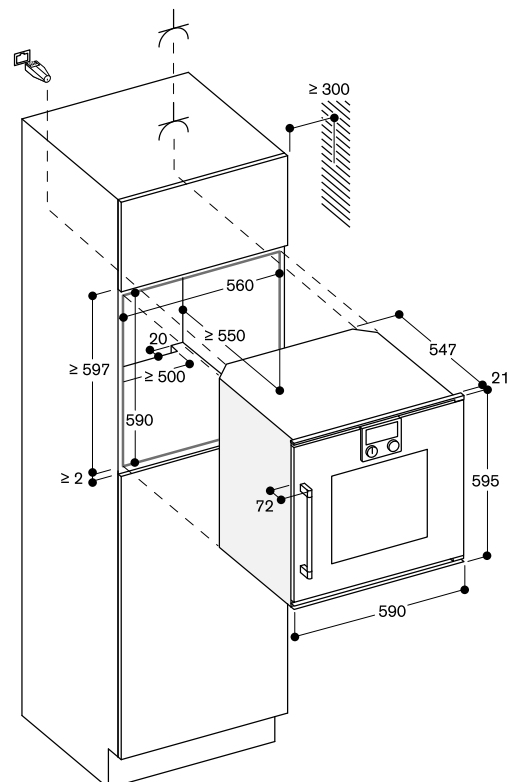

measurements in mm

*Energy efficiency class: at a range of energy efficiency classes from A+++ to D.



Controls at the top

Right-hinged

BOP 210 102

Full glass door in Gaggenau Anthracite
Width 60 cm

BOP 210 112

Full glass door in Gaggenau Metallic
Width 60 cm

BOP 210 132

Full glass door in Gaggenau Silver
Width 60 cm

Left-hinged

BOP 211 102

Full glass door in Gaggenau Anthracite
Width 60 cm

BOP 211 112

Full glass door in Gaggenau Metallic
Width 60 cm

BOP 211 132

Full glass door in Gaggenau Silver
Width 60 cm



Included in the price

- 1 baking tray, enamelled pyrolysis-safe
- 1 wire rack
- 1 enamelled tray

Special accessories

BA 036 102

Wire rack, chromium-plated
Without opening, with feet.

BA 046 117

Glass tray
24 mm deep.

BA 056 115

Heating element for baking stone and
Gastronorm roaster.

BA 056 130

Baking stone.
Incl. baking stone support and pizza
paddle (heating element must be
ordered separately).

Not in combination with pull-out system.

BA 216 102

Quadruple telescopic pull-out rack
For oven BOP 210/BOP 211.

BA 226 102

Grill tray, enamelled
37 mm deep.

BA 226 112

Baking tray, enamelled
24 mm deep.

BS 020 002

Pizza paddle, set of 2.

Oven 200 series

BOP 210/BOP 211

- Flush installation
- 9 heating methods, with baking stone function
- TFT touch display
- Panel-free appliance with surface control module
- Electronic temperature control from 50 °C to 300 °C
- Net volume 76 litres

Heating methods

Hot air.

Eco hot air.

Top + bottom heat.

Top heat.

Bottom heat.

Hot air + bottom heat.

Full surface grill + circulated air.

Full surface grill.

Baking stone function.

Handling

Rotary knob and TFT touch display operation.

Clear text display.

Option to save individual recipes.

Information key with use indicators.

Side-opening door opens up to 110° angle.

Features

Baking stone socket.

Actual temperature display.

Rapid heating.

Timer functions: cooking time, cooking time end, timer, stopwatch, long-term timer (certified by Star-K).

60 W halogen light on the top.

Chromium-plated wire racks on the side with 4 rack levels.

Selected digital services

(Home Connect)

Remote control and monitoring.

Recipes.

Please read additional information on

Home Connect on page 411.

Safety

Thermally insulated door with triple glazing.

Child lock.

Safety shut-off.

Cooled housing with temperature protection.

Cleaning

Gaggenau enamel.

Heated catalyser to clean the oven air.

Planning notes

Door hinge not reversible.

The door panel surface of the appliance extends 21 mm from the furniture cavity.

The outer edge of the door handle extends 72 mm from the furniture cavity.

Necessary lateral gap between appliance door and furniture panel of min. 5 mm.

Consider the overhang, incl. the door handle, when planning to open drawers next to the appliance.

When planning a corner solution, pay attention to the side-opening door and the minimum required distance to the wall.

For installation underneath cooktops: Distance between the underside of the cooktop and the top edge of the oven cavity: min. 15 mm.

The planning notes for the cooktops (particularly regarding ventilation, gas/electric connection) must be taken into account.

To achieve the 550 mm installation depth, the connection cable needs to follow the slanted edge on the corner of the housing.

The mains socket needs to be planned outside the built-in niche.

The LAN port can be found at the back on the upper right side.

Please read the installation details regarding oven combination on page 14 – 15.

Connection

Energy efficiency class A at a range of energy efficiency classes from A+++ to D.

Total connected load 3.7 kW.

Plan a connection cable.

Plan a LAN cable.



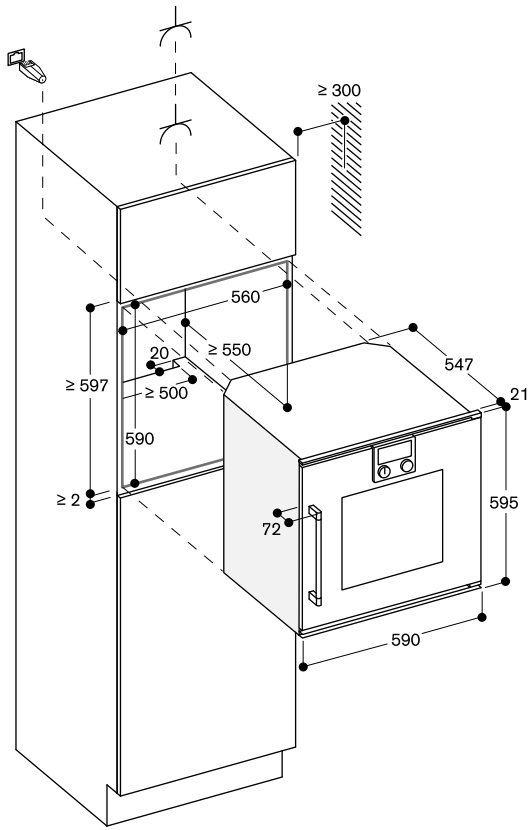

measurements in mm



Controls at the top

Right-hinged

BSP 270 101

Full glass door in Gaggenau Anthracite
Width 60 cm

BSP 270 111

Full glass door in Gaggenau Metallic
Width 60 cm

BSP 270 131

Full glass door in Gaggenau Silver
Width 60 cm

Left-hinged

BSP 271 101

Full glass door in Gaggenau Anthracite
Width 60 cm

BSP 271 111

Full glass door in Gaggenau Metallic
Width 60 cm

BSP 271 131

Full glass door in Gaggenau Silver
Width 60 cm



Included in the price

- 1 cooking container, stainless steel, perforated
- 1 cooking container, stainless steel, unperforated
- 1 wire rack
- 1 plug-in core temperature probe
- 1 outlet hose (3 m long)
- 1 water inlet hose (3 m long)
- 4 cleaning cartridges

Installation accessories

GF 111 100

Water descaling system

GF 121 110

Filter cartridge

GZ 010 011

Extension for water inlet and outlet
(2 m long)

Special accessories

BA 010 301

Triple telescopic pull-out rack
For combi-steam oven.

BA 020 361

Cooking container, stainless steel, unperforated, 46 mm deep, 5.4 l.

BA 020 370

Cooking container, stainless steel, perforated, 40 mm deep, 5 l.

BA 020 381

Cooking container, non-stick, unperforated, 46 mm deep, 5.4 l.

BA 020 390

Insert, non-stick, perforated, 40 mm deep, 5 l.

BA 046 117

Glass tray
24 mm deep.

CL S10 040

Cleaning cartridges, set of 4
For combi-steam ovens.

Combi-steam oven 200 series

BSP 270/BSP 271

- Flush installation
- Fixed inlet and outlet water connection
- Cleaning system, fully automatic
- Large cavity
- LED light source
- External steam generation
- Steaming without pressure
- Hot air 30 °C to 230 °C can be combined with chosen humidity level of 0%, 30%, 60%, 80% or 100%
- Sous-vide cooking with accurate temperature regulation
- Full surface grill combinable with circulated air up to 230 °C and steam
- Automatic programmes
- Core temperature probe with estimation of cooking time
- Hot air fan rotates in both directions for ideal heat distribution
- TFT touch display
- Panel-free appliance with surface control module
- Electronic temperature control from 30 °C bis 230 °C
- Net volume 50 litres

Heating methods

Hot air + 100 % humidity.

Hot air + 80 % humidity.

Hot air + 60 % humidity.

Hot air + 30 % humidity.

Hot air + 0 % humidity.

Low temperature cooking.

Sous-vide cooking.

Full surface grill level 1 + humidity.

Full surface grill level 2 + humidity.

Full surface grill + circulated air.

Dough proofing.

Defrosting.

Regenerating.

Handling

Rotary knob and TFT touch display operation.

Clear text display.

Option to save individual recipes (incl. core temperature probe).

Personalisation of automatic programmes.

Information key with use indicators.

Side-opening door opens up to 110° angle.

Features

Full surface grill 2 kW.

Steam removal.

Misting.

Three-point core temperature probe with automatic shut-off and estimation of cooking time.

Automatic programmes.

Actual temperature display.

Timer functions: cooking time, cooking time end, timer, stopwatch, long-term timer (certified by Star-K).

Automatic boiling point detection.

LED light on the side.

Hygienic stainless steel cooking interior.

3 tray levels.

Selected digital services

(Home Connect)

Automatic programmes.

Remote control and monitoring.

Recipes.

Please read additional information on Home Connect on page 411.

GN 010 330

Adapter for gastronorm insert and roaster.

GN 114 130

Gastronorm insert, stainless steel, GN 1/3

Unperforated, 40 mm deep, 1.5 l.

GN 114 230

Gastronorm insert, stainless steel, GN 2/3

Unperforated, 40 mm deep, 3 l.

GN 124 130

Gastronorm insert, stainless steel, GN 1/3

Perforated, 40 mm deep, 1.5 l.

GN 124 230

Gastronorm insert, stainless steel, GN 2/3

Perforated, 40 mm deep, 3 l.

GN 340 230

Gastronorm roaster in cast aluminium. GN 2/3, height 165 mm, non-stick.

Safety

Child lock.

Safety shut-off.

Cooled housing with temperature protection.

Cleaning

Cleaning programme, fully automatic. Descaling programme for the steam generator.

Drying function.

Automatic drying of the cavity at the end of the cooking process.

Strainer filter, removable.

Demo cleaning programme.

Planning notes

Door hinge not reversible.

No other electrical appliances should be installed above the BS.

At no point may the outlet hose be positioned higher than the bottom edge of the appliance. The outlet hose must also be at least 100 mm lower than the appliance outlet (see drawing "drainage connection").

Inlet hose can be extended once.

The outlet hose must not be longer than a maximum of 5 m.

The water connection (1) for the inlet hose must always be accessible and not located directly behind the appliance.

The connection of the outlet hose to the siphon (2) must not be directly behind the appliance and should be accessible.

The descaling system GF 111 100 (3) may be installed when connecting the appliance if the water hardness exceeds 7° dH.

The door panel surface of the appliance extends 21 mm from the furniture cavity. The outer edge of the door handle extends 72 mm from the furniture cavity. Necessary lateral gap between appliance door and furniture panel of min. 5 mm.

Consider the overhang, incl. the door handle, when planning to open drawers next to the appliance.

When planning a corner solution, pay attention to the side-opening door and the minimum required distance to the wall.

The mains socket needs to be planned outside the built-in niche.

Special accessories (order as spare parts):

Part No. 17002490 Descaling tablets

Please read the installation details regarding oven combination on page 14 – 15.

Connection

Energy efficiency class A at a range of energy efficiency classes from A+++ to D.

Total connected load 3.15 kW.

Connecting cable 1.8 m with plug.

Plan a LAN cable.

Inlet hose 3,0 m with connection pipe thread ISO228-G 3/4" (Ø 26,4 mm) extendable.

Outlet hose (Ø 25 mm) 3,0 m (HT-Hose).



*Energy efficiency class: at a range of energy efficiency classes from A+++ to D.

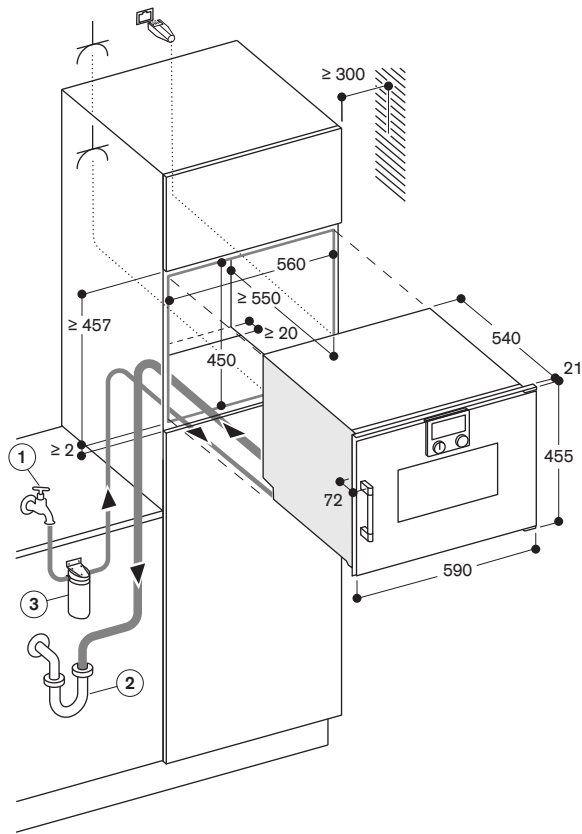

Socket

measurements in mm

Side view of BSP 260/270 above BOP

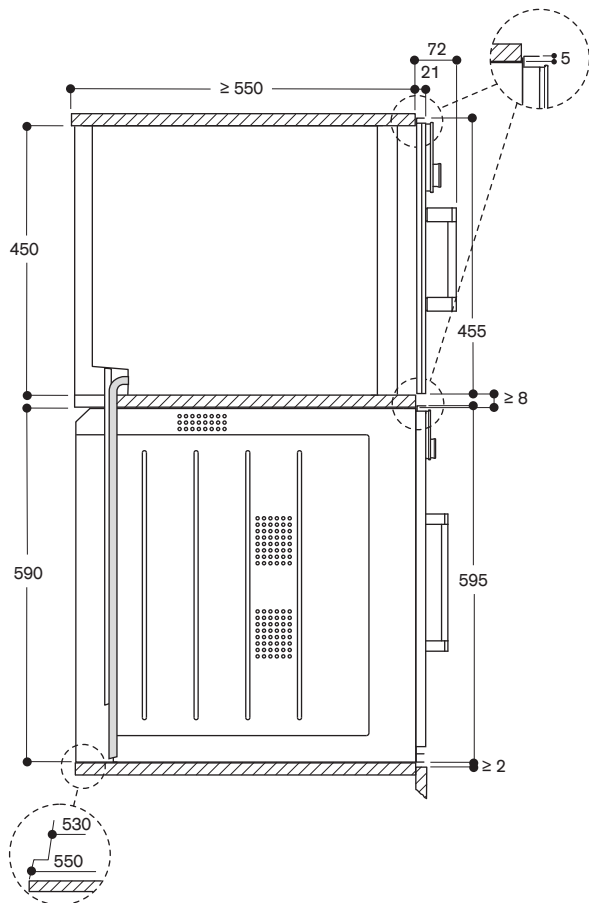

measurements in mm

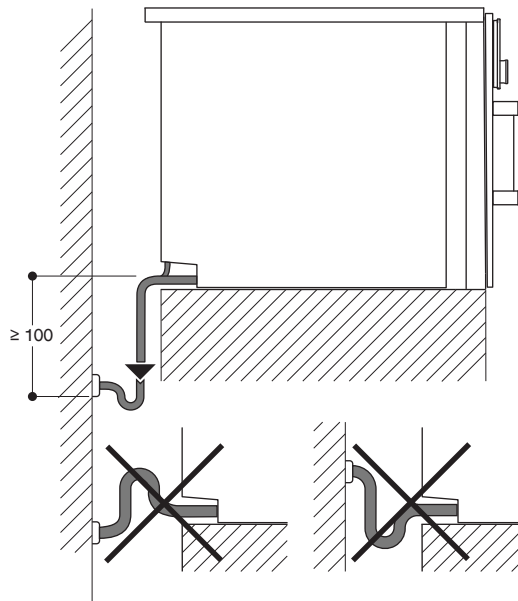

measurements in mm

View from rear

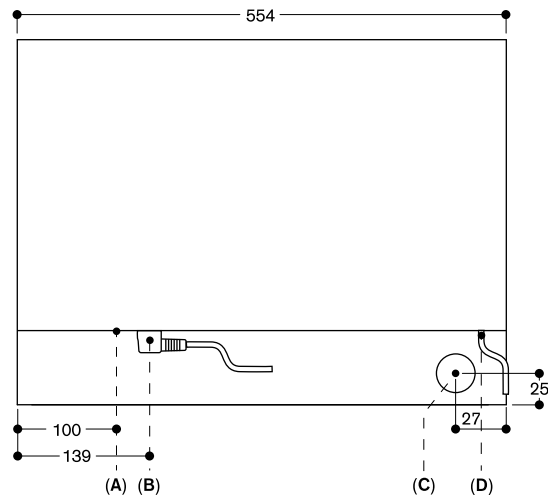

- A: LAN connection
- B: Electric terminal box
- C: Water outlet
- D: Cold water inlet

measurements in mm



Controls at the top

Right-hinged

BSP 260 101

Full glass door in Gaggenau Anthracite
Width 60 cm

BSP 260 111

Full glass door in Gaggenau Metallic
Width 60 cm

BSP 260 131

Full glass door in Gaggenau Silver
Width 60 cm

Left-hinged

BSP 261 101

Full glass door in Gaggenau Anthracite
Width 60 cm

BSP 261 111

Full glass door in Gaggenau Metallic
Width 60 cm

BSP 261 131

Full glass door in Gaggenau Silver
Width 60 cm



Included in the price

- 1 cooking container, stainless steel, perforated
- 1 cooking container, stainless steel, unperforated
- 1 wire rack
- 1 plug-in core temperature probe
- 1 outlet hose (3 m long)
- 1 water inlet hose (3 m long)

Installation accessories

GF 111 100

Water descaling system

GF 121 110

Filter cartridge

GZ 010 011

Extension for water inlet and outlet
(2 m long)

Special accessories

BA 010 301

Triple telescopic pull-out rack
For combi-steam oven.

BA 020 361

Cooking container, stainless steel, unperforated, 46 mm deep, 5.4 l.

BA 020 370

Cooking container, stainless steel, perforated, 40 mm deep, 5 l.

BA 020 381

Cooking container, non-stick, unperforated, 46 mm deep, 5.4 l.

BA 020 390

Insert, non-stick, perforated, 40 mm deep, 5 l.

BA 046 117

Glass tray
24 mm deep.

GN 010 330

Adapter for gastronorm insert and roaster.

Combi-steam oven 200 series

BSP 260/BSP 261

- Flush installation
- Fixed inlet and outlet water connection
- Large cavity
- LED light source
- External steam generation
- Steaming without pressure
- Hot air 30 °C to 230 °C can be combined with chosen humidity level of 0%, 30%, 60%, 80% or 100%
- Sous-vide cooking with accurate temperature regulation
- Full surface grill combinable with circulated air up to 230 °C and steam
- Automatic programmes
- Core temperature probe with estimation of cooking time
- Hot air fan rotates in both directions for ideal heat distribution
- TFT touch display
- Panel-free appliance with surface control module
- Electronic temperature control from 30 °C bis 230 °C
- Net volume 50 litres

Heating methods

Hot air + 100 % humidity.

Hot air + 80 % humidity.

Hot air + 60 % humidity.

Hot air + 30 % humidity.

Hot air + 0 % humidity.

Low temperature cooking.

Sous-vide cooking.

Full surface grill level 1 + humidity.

Full surface grill level 2 + humidity.

Full surface grill + circulated air.

Dough proofing.

Defrosting.

Regenerating.

Handling

Rotary knob and TFT touch display operation.

Clear text display.

Option to save individual recipes (incl. core temperature probe).

Personalisation of automatic programmes.

Information key with use indicators.

Side-opening door opens up to 110° angle.

Features

Full surface grill 2 kW.

Steam removal.

Misting.

Three-point core temperature probe with automatic shut-off and estimation of cooking time.

Automatic programmes.

Actual temperature display.

Timer functions: cooking time, cooking time end, timer, stopwatch, long-term timer (certified by Star-K).

Automatic boiling point detection.

LED light on the side.

Hygienic stainless steel cooking interior.

3 tray levels.

Selected digital services

(Home Connect)

Automatic programmes.

Remote control and monitoring.

Recipes.

Please read additional information on Home Connect on page 411.

GN 114 130

Gastronorm insert, stainless steel, GN 1/3

Unperforated, 40 mm deep, 1.5 l.

GN 114 230

Gastronorm insert, stainless steel, GN 2/3

Unperforated, 40 mm deep, 3 l.

GN 124 130

Gastronorm insert, stainless steel, GN 1/3

Perforated, 40 mm deep, 1.5 l.

GN 124 230

Gastronorm insert, stainless steel, GN 2/3

Perforated, 40 mm deep, 3 l.

GN 340 230

Gastronorm roaster in cast aluminium.

GN 2/3, height 165 mm, non-stick.

Safety

Child lock.

Safety shut-off.

Cooled housing with temperature protection.

Cleaning

Cleaning aid.

Descaling programme for the steam generator.

Drying function.

Automatic drying of the cavity at the end of the cooking process.

Grease filter, dishwasher-safe.

Strainer filter, removable.

Planning notes

Door hinge not reversible.

No other electrical appliances should be installed above the BS.

At no point may the outlet hose be positioned higher than the bottom edge of the appliance. The outlet hose must also be at least 100 mm lower than the appliance outlet (see drawing "drainage connection").

Inlet hose can be extended once.

The outlet hose must not be longer than a maximum of 5 m.

The water connection (1) for the inlet hose must always be accessible and not located directly behind the appliance.

The connection of the outlet hose to the siphon (2) must not be directly behind the appliance and should be accessible.

The descaling system GF 111 100 (3) may be installed when connecting the appliance if the water hardness exceeds 7° dH.

The door panel surface of the appliance extends 21 mm from the furniture cavity.

The outer edge of the door handle extends 72 mm from the furniture cavity. Necessary lateral gap between appliance door and furniture panel of min. 5 mm.

Consider the overhang, incl. the door handle, when planning to open drawers next to the appliance.

When planning a corner solution, pay attention to the side-opening door and the minimum required distance to the wall.

The mains socket needs to be planned outside the built-in niche.

Special accessories (order as spare parts):

Part No. 17002490 Descaling tablets

Please read the installation details regarding oven combination on page 14 – 15.

Connection

Energy efficiency class A at a range of energy efficiency classes from A+++ to D.

Total connected load 3.15 kW.

Connecting cable 1.8 m with plug.

Plan a LAN cable.

Inlet hose 3,0 m with connection pipe thread ISO228-G 3/4" (Ø 26,4 mm) extendable.

Outlet hose (Ø 25 mm) 3,0 m (HT-Hose).



*Energy efficiency class: at a range of energy efficiency classes from A+++ to D.

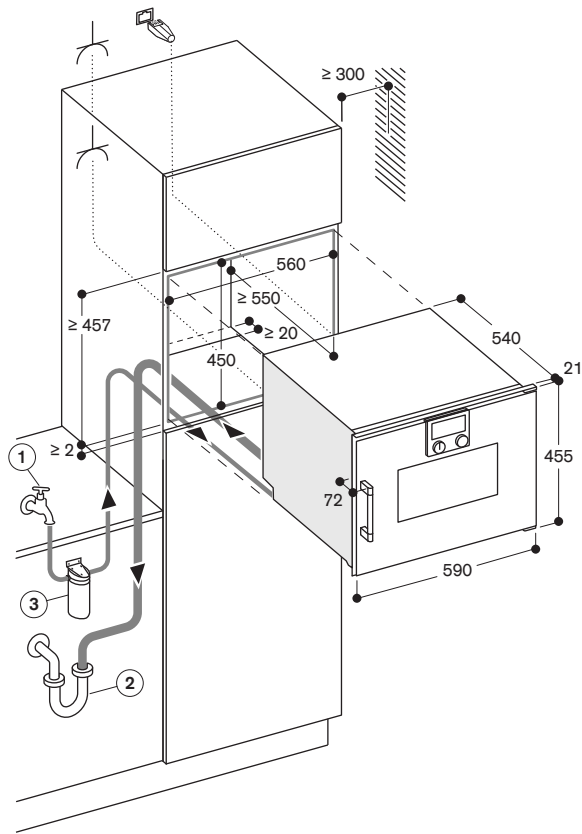

Socket

measurements in mm

Side view of BSP 260/270 above BOP

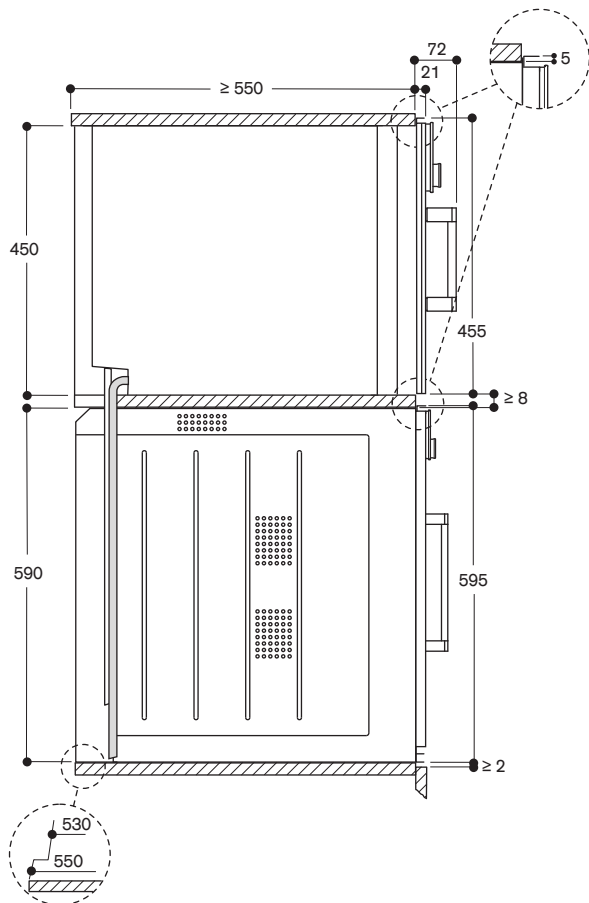

measurements in mm

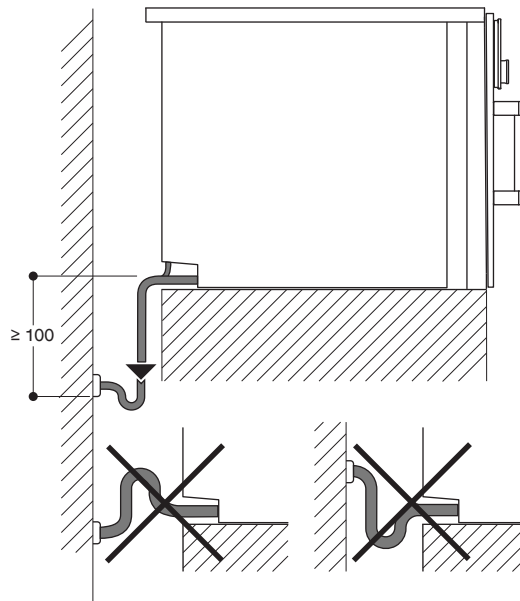

measurements in mm

View from rear

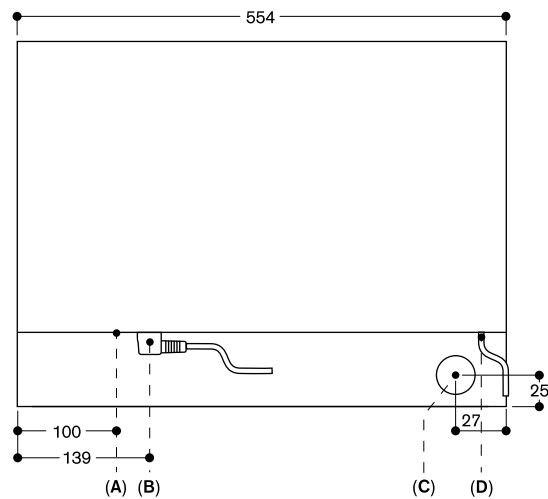

- A: LAN connection
- B: Electric terminal box
- C: Water outlet
- D: Cold water inlet

measurements in mm



Controls at the top

Right-hinged

BSP 250 101

Full glass door in Gaggenau Anthracite
Width 60 cm

BSP 250 111

Full glass door in Gaggenau Metallic
Width 60 cm

BSP 250 131

Full glass door in Gaggenau Silver
Width 60 cm

Left-hinged

BSP 251 101

Full glass door in Gaggenau Anthracite
Width 60 cm

BSP 251 111

Full glass door in Gaggenau Metallic
Width 60 cm

BSP 251 131

Full glass door in Gaggenau Silver
Width 60 cm



Included in the price

- 1 cooking container, stainless steel, perforated
- 1 cooking container, stainless steel, unperforated
- 1 wire rack
- 1 plug-in core temperature probe

Special accessories

BA 010 301

Triple telescopic pull-out rack
For combi-steam oven.

BA 020 361

Cooking container, stainless steel, unperforated, 46 mm deep, 5.4l.

BA 020 370

Cooking container, stainless steel, perforated, 40 mm deep, 5l.

BA 020 381

Cooking container, non-stick, unperforated, 46 mm deep, 5.4l.

BA 020 390

Insert, non-stick, perforated, 40 mm deep, 5l.

BA 046 117

Glass tray
24 mm deep.

GN 010 330

Adapter for gastronorm insert and roaster.

GN 114 130

Gastronorm insert, stainless steel, GN 1/3

Unperforated, 40 mm deep, 1.5l.

GN 114 230

Gastronorm insert, stainless steel, GN 2/3

Unperforated, 40 mm deep, 3l.

GN 124 130

Gastronorm insert, stainless steel, GN 1/3

Perforated, 40 mm deep, 1.5l.

Combi-steam oven 200 series

BSP 250/BSP 251

- Flush installation
- Water tank for fresh and waste water
- Large cavity
- LED light source
- External steam generation
- Steaming without pressure
- Hot air 30 °C to 230 °C can be combined with chosen humidity level of 0%, 30%, 60%, 80% or 100%
- Sous-vide cooking with accurate temperature regulation
- Full surface grill combinable with circulated air up to 230 °C and steam
- Automatic programmes
- Core temperature probe with estimation of cooking time
- Hot air fan rotates in both directions for ideal heat distribution
- TFT touch display
- Panel-free appliance with surface control module
- Electronic temperature control from 30 °C bis 230 °C
- Net volume 50 litres

Heating methods

Hot air + 100 % humidity.

Hot air + 80 % humidity.

Hot air + 60 % humidity.

Hot air + 30 % humidity.

Hot air + 0 % humidity.

Low temperature cooking.

Sous-vide cooking.

Full surface grill level 1 + humidity.

Full surface grill level 2 + humidity.

Full surface grill + circulated air.

Dough proofing.

Defrosting.

Regenerating.

Handling

Rotary knob and TFT touch display operation.

Clear text display.

Option to save individual recipes (incl. core temperature probe).

Personalisation of automatic programmes.

Information key with use indicators.

Side-opening door opens up to 110° angle.

Features

Full surface grill 2 kW.

2 removable 1.7 litre water tanks.

Water level warning.

Three-point core temperature probe with automatic shut-off and estimation of cooking time.

Automatic programmes.

Actual temperature display.

Timer functions: cooking time, cooking time end, timer, stopwatch, long-term timer (certified by Star-K).

Automatic boiling point detection.

LED light on the side.

Hygienic stainless steel cooking interior.

3 tray levels.

Selected digital services

(Home Connect)

Automatic programmes.

Remote control and monitoring.

Recipes.

Please read additional information on Home Connect on page 411.

GN 124 230

Gastronorm insert, stainless steel, GN 2/3

Perforated, 40 mm deep, 3l.

GN 340 230

Gastronorm roaster in cast aluminium.

GN 2/3, height 165 mm, non-stick.

Safety

Child lock.

Safety shut-off.

Cooled housing with temperature protection.

Cleaning

Cleaning aid.

Descaling programme for the steam generator.

Drying function.

Automatic drying of the cavity at the end of the cooking process.

Water tank, dishwasher-safe.

Grease filter, dishwasher-safe.

Strainer filter, removable.

Planning notes

Door hinge not reversible.

No other electrical appliances should be installed above the BS.

The door panel surface of the appliance extends 21 mm from the furniture cavity.

The outer edge of the door handle extends 72 mm from the furniture cavity.

Necessary lateral gap between appliance door and furniture panel of min. 5 mm.

Consider the overhang, incl. the door handle, when planning to open drawers next to the appliance.

When planning a corner solution, pay attention to the side-opening door and the minimum required distance to the wall.

The mains socket needs to be planned outside the built-in niche.

The LAN port can be found at the back on the lower left side.

Special accessories (order as spare parts):

Part No. 17002490 Descaling tablets

Please read the installation details regarding oven combination on page 14 – 15.

Connection

Energy efficiency class A at a range of energy efficiency classes from A+++ to D.

Total connected load 3.15 kW.

Connecting cable 1.8 m with plug.

Plan a LAN cable.



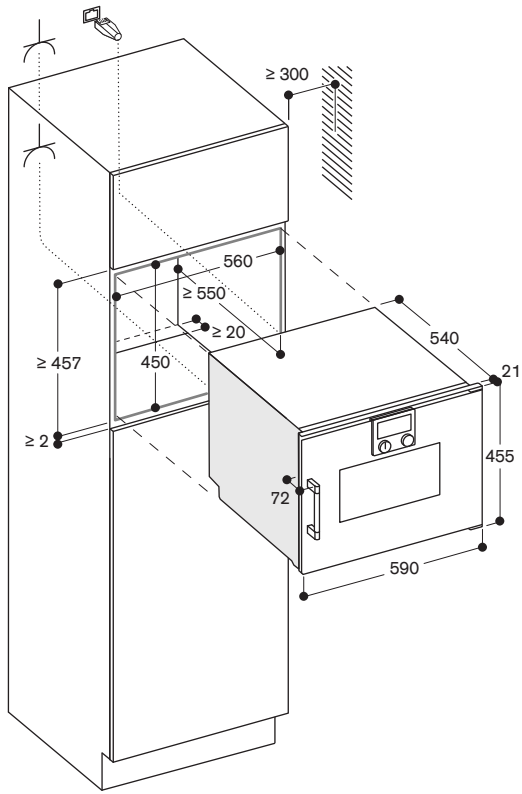

Socket
measurements in mm

Side view of BSP 220/250 above BOP

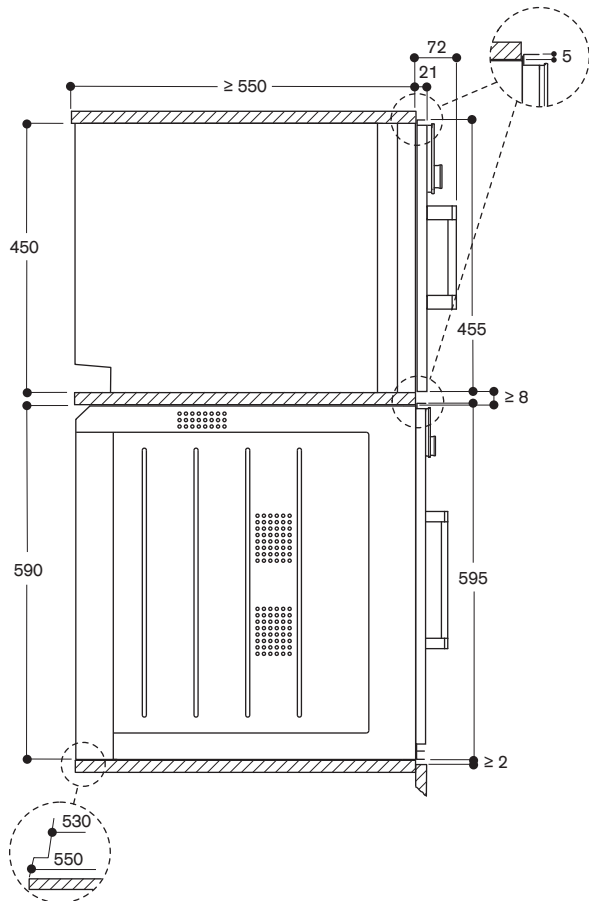

measurements in mm



Controls at the top

Right-hinged

BSP 220 101

Full glass door in Gaggenau Anthracite
Width 60 cm

BSP 220 111

Full glass door in Gaggenau Metallic
Width 60 cm

BSP 220 131

Full glass door in Gaggenau Silver
Width 60 cm

Left-hinged

BSP 221 101

Full glass door in Gaggenau Anthracite
Width 60 cm

BSP 221 111

Full glass door in Gaggenau Metallic
Width 60 cm

BSP 221 131

Full glass door in Gaggenau Silver
Width 60 cm

Included in the price

- 1 cooking container, stainless steel, perforated
- 1 cooking container, stainless steel, unperforated
- 1 wire rack

Special accessories

BA 220 360

Cooking container, stainless steel, unperforated, 35 mm deep, 5l.

BA 220 370

Cooking container, stainless steel, perforated, 35 mm deep, 5l.

BA 046 117

Glass tray
24 mm deep.

CL S30 040

Descaling tablets, set of 4.

For combi-steam ovens and steam ovens.

GN 114 130

Gastronorm insert, stainless steel, GN 1/3
Unperforated, 40 mm deep, 1.5l.

GN 114 230

Gastronorm insert, stainless steel, GN 2/3
Unperforated, 40 mm deep, 3l.

GN 124 130

Gastronorm insert, stainless steel, GN 1/3
Perforated, 40 mm deep, 1.5l.

GN 124 230

Gastronorm insert, stainless steel, GN 2/3
Perforated, 40 mm deep, 3l.

Steam oven 200 Series

BSP 220/BSP 221

- Flush installation
- Water tank
- Large cavity
- LED light source
- External steam generation
- Steaming without pressure with 100% humidity from 30 °C to 100 °C
- Sous-vide cooking with accurate temperature regulation
- TFT touch display
- Panel-free appliance with surface control module
- Electronic temperature control from 30 °C bis 100 °C
- Net volume 59 litres

Heating methods

100 % humidity.

Sous-vide cooking.

Dough proofing.

Defrosting.

Regenerating.

Low temperature steaming.

Handling

Rotary knob and TFT touch display operation.

Clear text display.

Information key with use indicators.

Side-opening door opens up to 110° angle.

Features

Removable 1.7 litre water tank.

Water level warning.

Actual temperature display.

Timer functions: cooking time, cooking time end, timer, stopwatch, long-term timer (certified by Star-K).

Automatic boiling point detection.

LED light on the side.

Hygienic stainless steel cooking interior.
3 tray levels.

Selected digital services

(Home Connect)

Remote control and monitoring.

Recipes.

Please read additional information on Home Connect on page 411.

Safety

Child lock.

Safety shut-off.

Cooled housing with temperature protection.

Cleaning

Cleaning aid.

Descaling programme for the steam generator.

Planning notes

Door hinge not reversible.

No other electrical appliances should be installed above the BS.

The door panel surface of the appliance extends 21 mm from the furniture cavity.

The outer edge of the door handle extends 72 mm from the furniture cavity.

Necessary lateral gap between appliance door and furniture panel of min. 5 mm.

Consider the overhang, incl. the door handle, when planning to open drawers next to the appliance.

When planning a corner solution, pay attention to the side-opening door and the minimum required distance to the wall.

The mains socket needs to be planned outside the built-in niche.

The LAN port can be found at the back on the lower left side.

Special accessories (order as spare parts):

Part No. 17002490 Descaling tablets

Please read the installation details regarding oven combination on page 14 – 15.

Connection

Total connected load 2.75 kW.

Connecting cable 1.8 m with plug.

Plan a LAN cable.



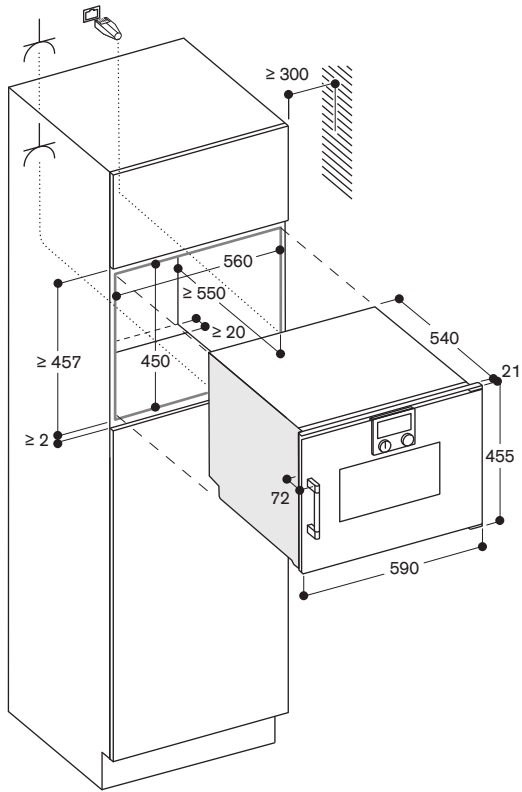

Socket
 measurements in mm

Side view of BSP 220/250 above BOP

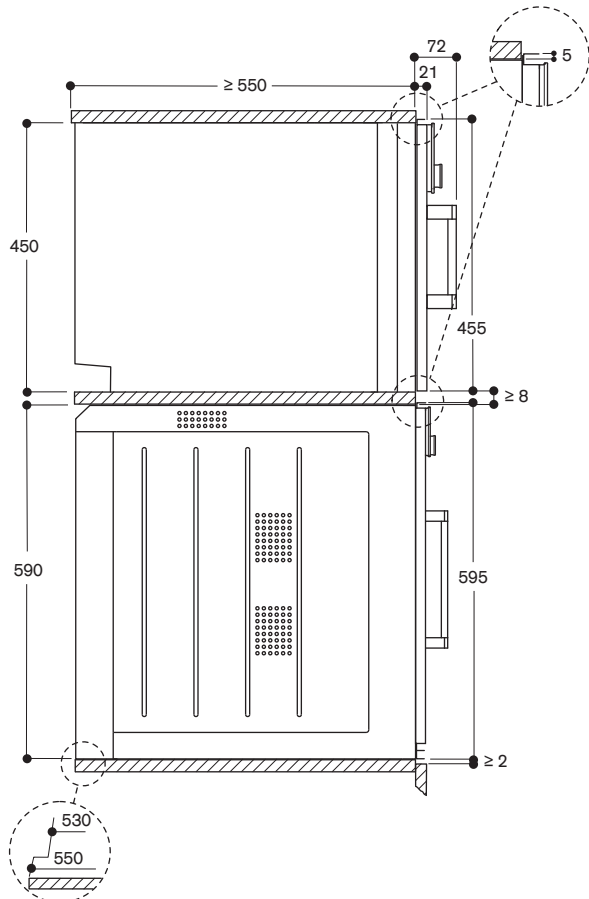

measurements in mm



Controls at the top

Right-hinged

BMP 250 100

Full glass door in Gaggenau Anthracite
Width 60 cm

BMP 250 110

Full glass door in Gaggenau Metallic
Width 60 cm

BMP 250 130

Full glass door in Gaggenau Silver
Width 60 cm

Left-hinged

BMP 251 100

Full glass door in Gaggenau Anthracite
Width 60 cm

BMP 251 110

Full glass door in Gaggenau Metallic
Width 60 cm

BMP 251 130

Full glass door in Gaggenau Silver
Width 60 cm

Included in the price

- 1 combination wire rack
- 1 glass tray

Combi-microwave oven 200 series

BMP 250/BMP 251

- Flush installation
- Single operation and combination of microwave, grill and oven
- Sequential operation of up to 5 modes incl. programming of combined operation and rest time
- TFT touch display
- Panel-free appliance with surface control module
- Electronic temperature control
- Interior volume 36 litres

Programmes

Microwave operation with 5 output levels: 1000, 600, 360, 180, 90 W.

Oven operation with 4 heating methods: Hot air 40 °C and from 100 °C to 250 °C, Full surface grill + hot air from 100 °C to 250 °C,

Full surface grill + circulated air from 100 °C to 250 °C,

Full surface grill with 3 levels of intensity, maximum output 2000 W.

Heating methods with microwave output levels 600, 360, 180 and 90 W freely combinable.

15 automatic programmes with weight indication, customisable:

4 defrosting programmes

4 cooking programmes

7 combination programmes

Option to save individual recipes.

Handling

Rotary knob and TFT touch display operation.

Clear text display.

Information key with use indicators.

Side-opening door opens up to 110° angle.

Features

Innowave.

Rapid heating.

4 tray levels.

Actual temperature display.

60 W halogen light on the side.

Timer functions: cooking time, cooking time end, timer, stopwatch, long-term timer (certified by Star-K).

Safety

Thermally insulated door with triple glazing.

Triple door lock.

Child lock.

Safety shut-off.

Cooled housing with temperature protection.

Cleaning

Hygienic stainless steel interior with glass ceramic base.

Interior back wall with catalytic coating.

Planning notes

Door hinge not reversible.

Plan the niche without back wall.

Necessary lateral gap between appliance door and furniture panel of min. 5 mm.

The door panel surface of the appliance extends 21 mm from the furniture cavity.

The outer edge of the door handle extends 72 mm from the furniture cavity.

Consider the overhang, incl. the door handle, when planning to open drawers next to the appliance.

When planning a corner solution, pay attention to the side-opening door and the minimum required distance to the wall.

The mains socket needs to be planned outside of the built-in niche.

Please read the installation details regarding oven combination on page 14 – 15.

Connection

Total connected load 3.1 kW.

Connection cable 1.5 m without plug.



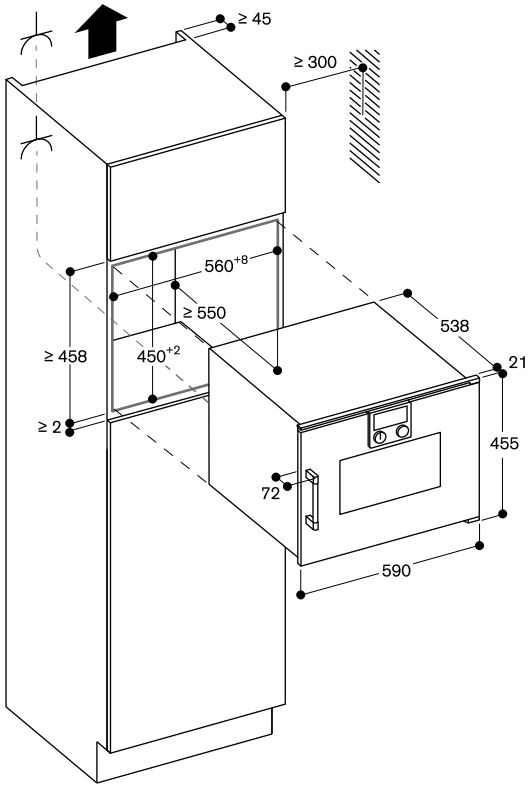

∇ Socket

measurements in mm

Side view of BMP over BOP

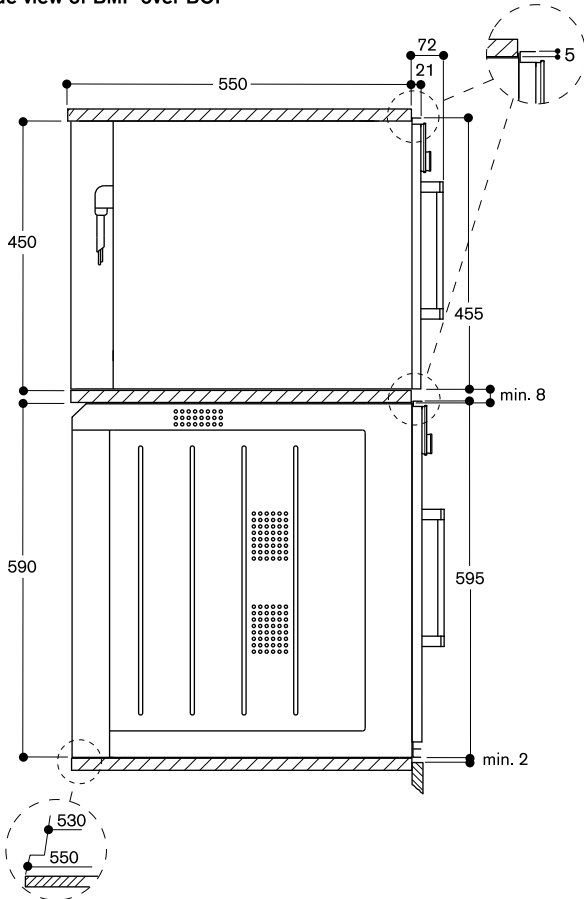



Controls at the bottom

Right-hinged

BMP 224 100

Full glass door in Gaggenau Anthracite
Width 60 cm

BMP 224 110

Full glass door in Gaggenau Metallic
Width 60 cm

BMP 224 130

Full glass door in Gaggenau Silver
Width 60 cm

Left-hinged

BMP 225 100

Full glass door in Gaggenau Anthracite
Width 60 cm

BMP 225 110

Full glass door in Gaggenau Metallic
Width 60 cm

BMP 225 130

Full glass door in Gaggenau Silver
Width 60 cm

Included in the price

- 1 glass tray
- 1 wire rack

Microwave oven 200 series

BMP 224/BMP 225

- Flush installation
- Handleless door / automatic door opening
- Single operation and combination of microwave and grill
- Sequential operation of up to 5 modes incl. programming of combined operation and rest time
- TFT touch display
- Electronic temperature control
- Interior volume 21 litres

Programmes

Microwave operation with 5 output levels: 900, 600, 360, 180, 90 W.

Full surface grill with 3 levels of intensity, maximum output 1300 W.

Full surface grill with microwave output levels 360, 180 and 90 W combinable. 10 automatic programmes with weight indication:

3 defrosting programmes

4 cooking programmes

3 combination programmes

Option to save individual recipes.

Handling

Automatic door opening.

Rotary knob and TFT touch display operation.

Clear text display.

Information key with use indicators.

Side-opening door opens up to 110° angle.

Features

Innowave.

Actual temperature display.

25 W interior light.

Hygienic stainless steel interior with glass ceramic base.

Safety

Thermally insulated door with double glazing.

Triple door lock.

Child lock.

Safety shut-off.

Cooled housing with temperature protection.

Planning notes

Door hinge not reversible.

Minimum installation height 85 cm (top edge of niche bottom).

Height-adjustable feet.

Installation of BMP above BOP with intermediate shelf.

Necessary lateral gap between appliance door and furniture panel of min. 5 mm.

The door panel surface of the appliance extends 21 mm from the furniture cavity.

When planning a corner solution, pay attention to the side-opening door and the minimum required distance to the wall.

Please read the installation details regarding oven combination on page 14 – 15.

Connection

Total connected load 2.0 kW.

Connection cable 1.7 m, pluggable.



Installation in a tall cupboard

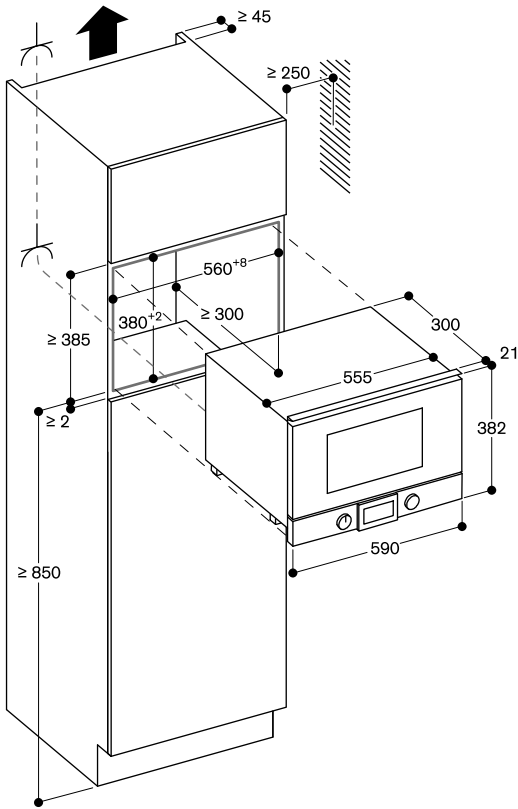

Socket
measurements in mm

Installation in a wall-hanging cupboard

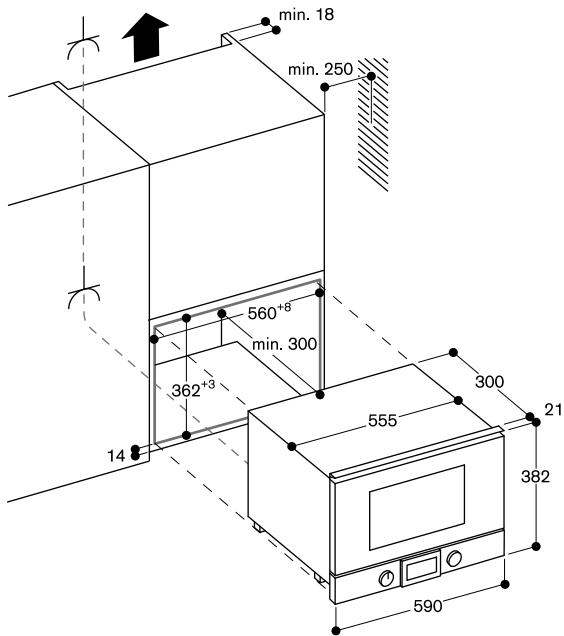

Side view of BMP 224/225 over BOP

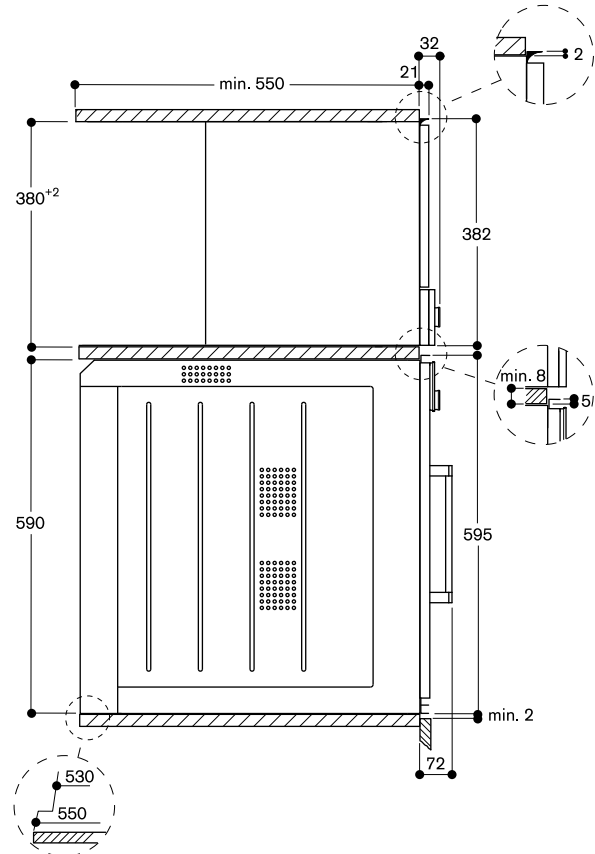



Controls at the top

Left-hinged

CMP 250 102

Full glass door in Gaggenau Anthracite
Width 60 cm

CMP 250 112

Full glass door in Gaggenau Metallic
Width 60 cm

CMP 250 132

Full glass door in Gaggenau Silver
Width 60 cm

Included in the price

- 1 assembly screws
- 1 scoop
- 1 test strip
- 1 milk container (insulated)
- 1 connection hose for milk frother
- 1 milk pipe

Fully automatic espresso machine 200 series

CMP 250

- Handless door / cushioned door closing system
- Continuous flow heater means no waiting time and constant brewing temperature
- Aroma brewing technology for a full aroma
- Single portion cleaning
- TFT touch display
- Panel-free appliance with surface control module
- One-touch operation
- Personalisation function
- 7 light settings
- Electronic fill level control for milk, water and coffee to ensure a perfect result

Type of beverage

Ristretto / 2 x Ristretto.
Espresso / 2 x Espresso.
Espresso Macchiato / 2 x Espresso Macchiato.
Coffee / 2 x Coffee.
Americano / 2 x Americano.
Caffe Latte / 2 x Caffe Latte.
Latte Macchiato / 2 x Latte Macchiato.
Cappuccino / 2 x Cappuccino.
Flat White / 2 x Flat White.
Milk froth / 2 x Milk froth.
Warm milk / 2 x Warm milk.
Hot water / 2 x Hot water.

Handling

Door with cushioned door closing system.
Rotary knob and TFT touch display operation.
Clear text display.
Personalisation function, option to save 8 individualised beverages.
4 beverage size settings, volume can be individually adjusted to match the size of the cup.
8 coffee strength levels from very mild to extra strong.
3 coffee temperature levels.
10 hot water temperature levels.
4 coffee-milk ratio levels.
Adjustable grinding level.
Height-adjustable coffee dispenser 7 cm to 15 cm.
Easy access to water tank, milk and coffee bean container behind the door.

Features

Maintenance-free grinding unit with ceramic discs.
Separate drawer for second ground coffee type.
Water pump with 19 bar pressure.
Double grinding and brewing cycles for extra intensity for single beverage order.
For double beverage order, two grinding and brewing cycles.
Beverage dispenser with integrated milk system.
Insulated stainless steel milk container for up to 0.5 litres.
Integrated lightning with LEDs.
Removable bean container with aroma protecting lid for 500 g allows for an effortless exchange of different types of coffee beans.
Automatic adjustment of ground coffee quantity.
Removable 2.4 litre water tank.

Electronic water filter exchange indicator.
Electronic fill level control for drip tray and container for coffee residue.
Hint: for energy-saving, the appliance switches to standby mode automatically after about 30 minutes. This timespan can be changed in the basic settings.

Selected digital services (Home Connect)

Coffee world: extended choice of coffee specialities from all over the world.
Remote control and monitoring.

Please read additional information on Home Connect on page 411.

Safety

Child lock.

Cleaning

Fully automatic rinse programme when machine is turned on/off.
Automatic steam cleaning of the milk system after every beverage.
Automatic cleaning and descaling programme.
Emptying programme to prepare the appliance for holiday or transportation.
Empty-grinding function to remove coffee residues from the system when switching bean types.
Removable brewing unit.
Dishwasher-safe coffee residue container and drip tray.
Dishwasher-safe beverage dispenser.

Planning notes

Ideal installation height 95 cm to 145 cm (top edge of niche bottom).
Necessary lateral gap between appliance front and furniture panel of min. 5 mm.
The door panel surface of the appliance extends 21 mm from the furniture cavity.
When installing in a corner a side clearance is required.
Door opening angle appr. 110° (delivery status) - mounting distance to the wall has to be at least 350 mm.
Door opening angle appr. 155° - mounting distance to the wall has to be at least 650 mm.
Door opening angle appr. 92° - mounting distance to the wall has to be at least 100 mm (spare part No. 00636455).
Installation directly above 14 cm high warming drawer in 59 cm standardised niche.
The LAN port can be found at the back on the lower right side.

Special accessories (order as spare parts - see also page 80 - 81):
Part No. 17000705 Water filter
Part No. region-specific Descaling tablets
Part No. region-specific Cleaning tablets
Part No. 00636455 Door hinge restrictor (92° opening angle)
Part No. 11015223 Bean container with lid

Please read the installation details regarding oven combination on page 14 - 15.

Connection

Total connected load 1.6 kW.
Connection cable 1.7 m with plug.
Plan a LAN cable.

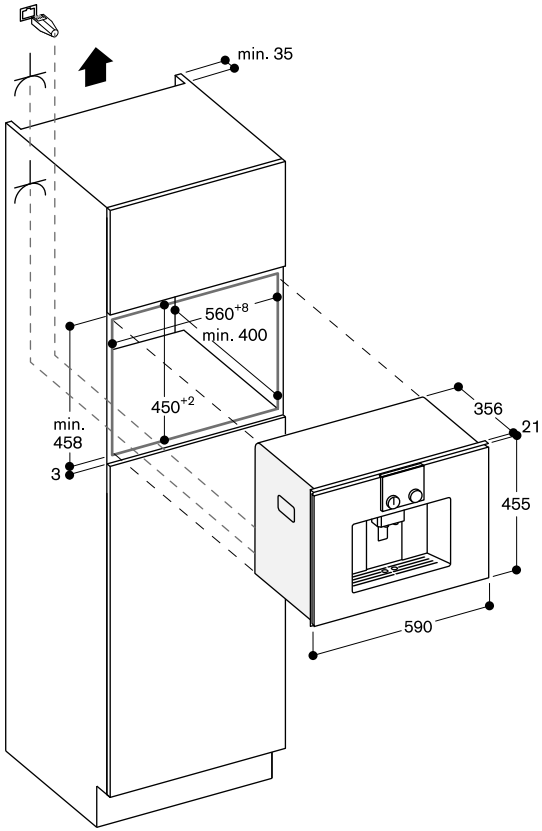



DVP 221 100

Glass front in Gaggenau Anthracite
Width 60 cm, Height 14 cm

DVP 221 110

Glass front in Gaggenau Metallic
Width 60 cm, Height 14 cm

DVP 221 130

Glass front in Gaggenau Silver
Width 60 cm, Height 14 cm

Included in the price

- 50 vacuuming bags, small
- 50 vacuuming bags, big
- 1 raised vacuuming platform
- 1 adaptor f. vacuuming outside the chamber
- 1 vacuuming hose
- 1 adaptor for bottle plugs
- 3 plugs for vacuuming of bottles

Vacuating drawer 200 series

DVP 221

- Integrable in 14 cm high niche
- Hygienic stainless steel vacuuming chamber, applicable height up to 80 mm
- 3 vacuuming levels for vacuuming in the chamber, max. 99%
- 3 vacuuming levels for vacuuming outside the chamber, max. 90%
- Automatic connection recognition for vacuuming outside the chamber
- Flush installation
- Handleless drawer
- Push-to-open system

Application

Vacuating for sous-vide cooking.
Vacuating for fast marinating and flavouring.
Vacuating for extended storage.
Vacuating of vacuuming containers outside the chamber.
Vacuating of liquids in bottles outside the chamber.

Handling

Touch key operation.

Features

Net volume 7 litres.
Capacity load max. 10 kg.
Maximum size of vacuuming bags W 240 mm x L 350 mm.
3 heat-sealing levels for different strengths of bag material.
Sealing bar, non-stick coating, removable.
Safety glass cover, opens automatically after vacuuming.
Raised vacuuming platform, 44 mm, deployable.
Utility space in vacuuming chamber, W 210 mm x L 275 mm.
Membrane for avoiding reflow of liquids during vacuuming outside the chamber.
Drying programme for vacuuming pump.
Warning function.

Planning notes

Necessary lateral gap between appliance front and furniture panel of min. 5 mm.
The panel surface of the appliance extends 21 mm from the furniture cavity.
Installation of BS/BM/CM directly above DV in 59 cm niche without intermediate floor.
Built-in under worktop or in single niche.
The socket can be planned behind the appliance.

Special accessories (order as spare parts):
Part No. 00578813 vacuuming bags, small
Part No. 00578814 vacuuming bags, big

Please read the installation details regarding oven combination on page 14 – 15.

Connection

Total connected load 0.32 kW.
Connection cable 1.5 m, pluggable.

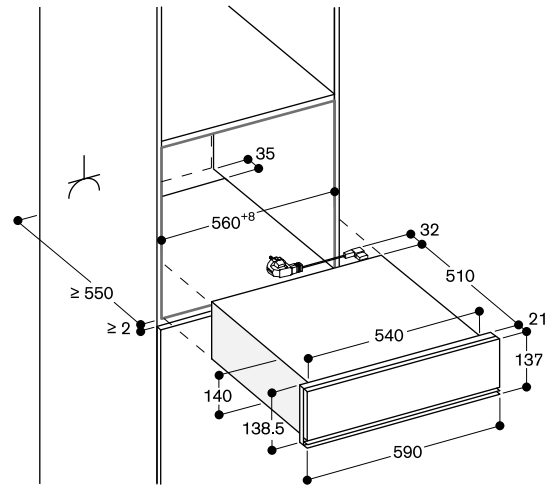

Socket

measurements in mm

Side view DVP 221 below BSP, BMP, CMP

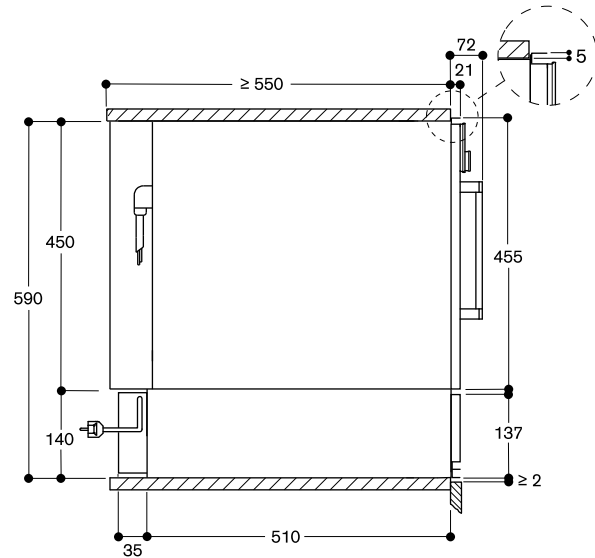

measurements in mm

**WSP 221 102**

Glass front in Gaggenau Anthracite
Width 60 cm, Height 14 cm

WSP 221 112

Glass front in Gaggenau Metallic
Width 60 cm, Height 14 cm

WSP 221 132

Glass front in Gaggenau Silver
Width 60 cm, Height 14 cm

Culinary warming drawer 200 series**WSP 221**

- Flush installation
- Handleless drawer
- Push-to-open system
- Hygienic stainless steel interior with glass bottom
- Direct temperature selection in the range 30 °C to 80 °C
- For slow cooking, dough proofing, herbs and fruits drying, chocolate melting and defrosting

Heating methods

Slow cooking.
Keeping meals warm.
Warming ovenware.
Cups and plates warming.
Direct temperature control.
Personalisation function via Home Connect.
16 additional programs via Home Connect.

Handling

Touch key operation.

Features

Net volume 20 litres.
Volume capacity: Dinner service for 6 people including ø27 cm plates and soup bowls, additional bowls and a serving dish depending on size.
Capacity load max. 25 kg.
Usable interior dimensions W547 mm x H 91 mm x D 410 mm.
Heating system for even heat distribution and stable cavity temperature.
Status display, visible in the glass front.
Glass bottom made of safety glass.

Selected digital services (Home Connect)

Additional programmes and recipes.
Remote control and monitoring.
Timing function.

Please read additional information on Home Connect on page 411.

Planning notes

Necessary lateral gap between appliance front and furniture panel of min. 5 mm.
The door panel surface of the appliance extends 21 mm from the furniture cavity.
Installation of BSP/BMP/CMP directly above WSP in 59 cm niche without intermediate floor.
The socket can be planned behind the appliance.

Please read the installation details regarding oven combination on page 14 – 15.

Connection

Total connected load 0.82 kW.
Connection cable 1.8m, pluggable.

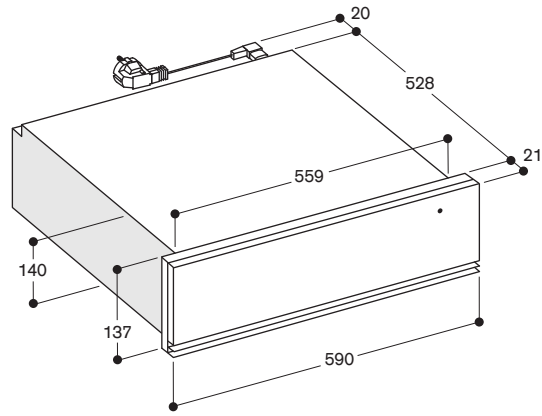

Measurements in mm

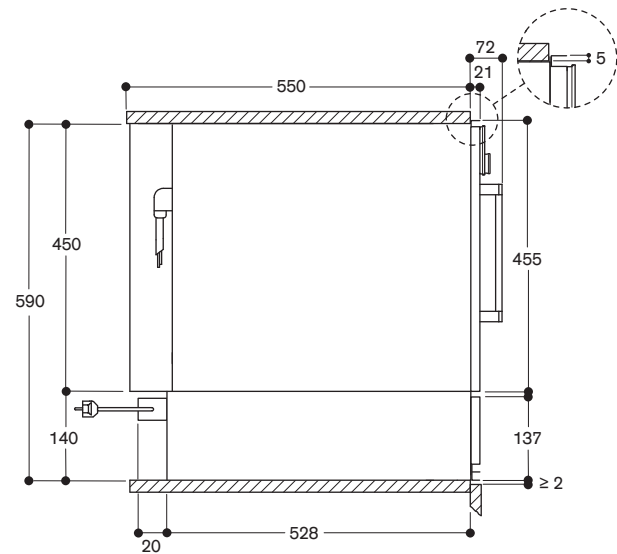
WSP 221 below BSP, BMP, CMP

Measurements in mm



WSP 222 102

Glass front in Gaggenau Anthracite
Width 60 cm, Height 29 cm

WSP 222 112

Glass front in Gaggenau Metallic
Width 60 cm, Height 29 cm

WSP 222 132

Glass front in Gaggenau Silver
Width 60 cm, Height 29 cm

Culinary warming drawer 200 series
WSP 222

- Flush installation
- Handleless drawer
- Push-to-open system
- Hygienic stainless steel interior with glass bottom
- Direct temperature selection in the range 30 °C to 80 °C
- For slow cooking, dough proofing, herbs and fruits drying, chocolate melting and defrosting

Heating methods

Slow cooking.
Keeping meals warm.
Warming ovenware.
Cups and plates warming.
Direct temperature control.
Personalisation function via Home Connect.
16 additional programs via Home Connect.

Handling

Touch key operation.

Features

Net volume 54 litres.
Volume capacity: Dinner service for 12 people including ø 27 cm plates and soup bowls, additional bowls and a serving dish depending on size.
Capacity load max. 25 kg.
Usable interior dimensions W547 mm x H 241 mm x D 410 mm.
Heating system for even heat distribution and stable cavity temperature.
Status display, visible in the glass front.
Glass bottom made of safety glass.

Selected digital services (Home Connect)

Additional programmes and recipes.
Remote control and monitoring.
Timing function.

Please read additional information on Home Connect on page 411.

Planning notes

Necessary lateral gap between appliance front and furniture panel of min. 5 mm.
The door panel surface of the appliance extends 21 mm from the furniture cavity.
The socket can be planned behind the appliance.

Please read the installation details regarding oven combination on page 14 – 15.

Connection

Total connected load 0.82 kW.
Connection cable 1.8 m, pluggable.

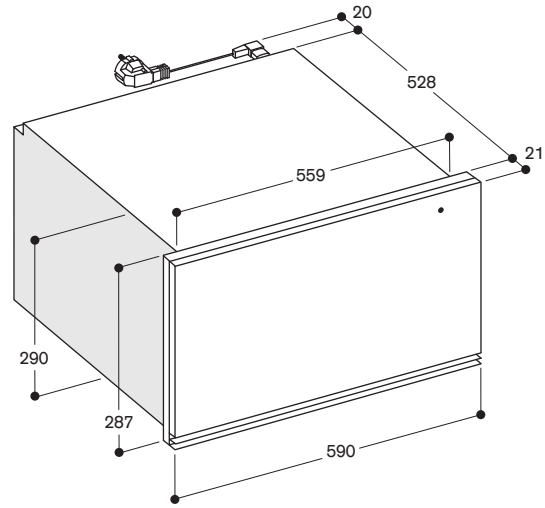

WSP 222 below BOP

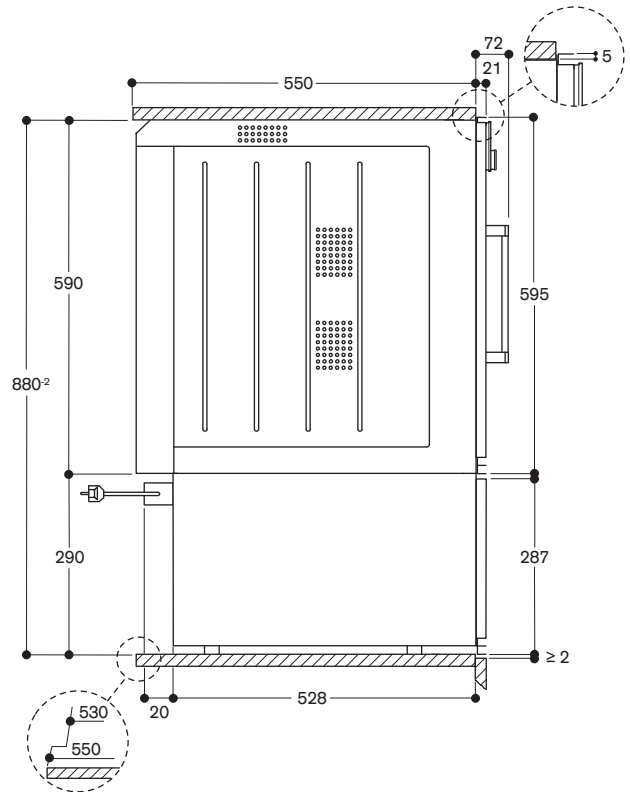

Measurements in mm

Accessories and special accessories 200 series

Advice: Not every illustrated accessory fits to every oven. For exact allocation see page 80 – 81.

BA 010 301
Triple telescopic pull-out rack
For combi-steam oven.



BA 016 105
Pull-out system
Fully extendable telescopic rails and enamelled cast iron frame.



BA 020 361
Cooking container, stainless steel,
unperforated, 46 mm deep, 5.4l.



BA 020 370
Cooking container, stainless steel,
perforated, 40 mm deep, 5l.



BA 020 381
Cooking container, non-stick,
unperforated, 46 mm deep, 5.4l.



BA 020 390
Cooking container, non-stick,
perforated, 40 mm deep, 5l.

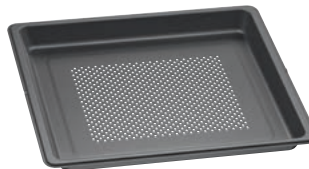

BA 026 115
Baking tray, enamelled
15 mm deep.



BA 036 105
Wire rack, chromium-plated
Without opening, with feet.

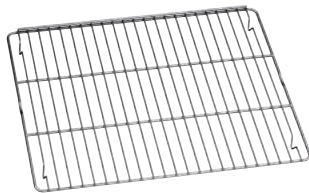

BA 046 117
Glass tray
24 mm deep.



BA 226 105
Grill tray, enamelled
30 mm deep.



BA 216 102
Quadruple telescopic pull-out rack
For ovens BOP 210/BOP 211.

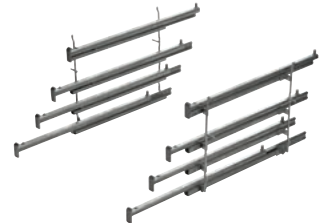

BA 056 115
Heating element for baking stone and
Gastronorm roaster.

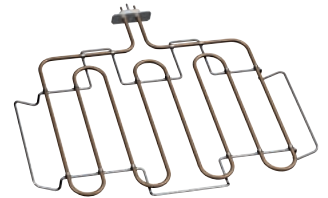

BA 056 130
Baking stone
Incl. baking stone support and pizza
paddle (heating element must be
ordered separately).
Not in combination with pull-out
system.



BA 056 133
Baking stone
Incl. baking stone support and pizza
paddle (heating element must be
ordered separately).
Not in combination with pull-out
system.

BA 220 360
Cooking container, stainless steel,
unperforated, 35 mm deep, 5l.



BA 220 370
Cooking container, stainless steel,
perforated, 35 mm deep, 5l.



BS 020 002
Pizza paddle, set of 2



GN 010 330

Adapter for gastronorm insert and roaster.

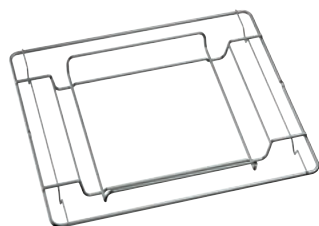
**GN 114 130**

Gastronorm insert, stainless steel, GN 1/3
Unperforated, 40 mm deep, 1.5l.

**GN 114 230**

Gastronorm insert, stainless steel, GN 2/3
Unperforated, 40 mm deep, 3l.

**GN 124 130**

Gastronorm insert, stainless steel, GN 1/3
Perforated, 40 mm deep, 1.5l.

**GN 124 230**

Gastronorm insert, stainless steel, GN 2/3
Perforated, 40 mm deep, 3l.

**GN 340 230**

Gastronorm roaster in cast aluminium GN 2/3, height 165 mm, non-stick.
For roasting in oven with roasting function.

Lower and upper part can also be used as separate ovenproof dishes, height 100 and 65 mm.

For ovens with heating element BA 056 115 or BA 058 115 and pull-out system BA 016 or BA 018 (both to be ordered separately) and for Combi-steam ovens with adapter GN 010 330 and pull-out system BA 010 301 (both to be ordered separately).

**CL S10 040**

Cleaning cartridges, set of 4.
For Combi-steam oven.

**GF 111 100**

Descaling and neutralising filter, for first installation.
Descaling system, recommended to be installed if water hardness exceeds 7 °dH or carbon hardness 5 °dH.
Filter head with integrated non-return valve and filter.
Width 130 mm, Height 265 mm, Depth 121 mm.
Water inlet 1.5 m with 3/4" connection.

**GF 121 110**

Filter cartridge

**GZ 010 011**

Extension for water inlet and outlet (2 m long).



Accessories and special accessories 200 series



BOP 250/BOP 251



BOP 220/BOP 221

			Oven	Oven
Baking tray, enamelled				
	BA 026 115	15 mm deep	•/°	•/°
Pull-out rack				
	BA 016 105	Pull-out system with fully extendable telescopic pull-out rack and pyrolysis-safe cast frame	°	°
	BA 216 102	Quadruple fully extendable telescopic pull-out rack. For oven BOP 210/BOP 211.		
	BA 010 301	Triple telescopic pull-out rack for combi-steam oven		
Oven surfaces with catalytic special enamelling				
	Part No. 664048	Oven ceiling, for retrofitting		
	Part No. 664248	Oven back wall, for retrofitting		
Baking stone				
	BA 056 130	incl. baking stone support and pizza paddle (heating element must be ordered separately)		
	BA 056 133	incl. baking stone support and pizza paddle (heating element must be ordered separately)	°	°
Cooking container, steam oven				
	BA 020 361	Cooking container, stainless steel, unperforated, 46 mm deep, 5.4 l		
	BA 020 370	Cooking container, stainless steel, perforated, 40 mm deep, 5 l		
	BA 020 381	Cooking container, non-stick, unperforated, 46 mm deep, 5.4 l		
	BA 020 390	Cooking container, non-stick, perforated, 40 mm deep, 5 l		
	BA 220 360	Cooking container, stainless steel, unperforated, 37.5 deep, 5 l		
	BA 220 370	Cooking container, stainless steel, perforated, 37.5 deep, 5 l		
	GN 114 130	GN 1/3, unperforated, 40 mm deep, 1.5 l		
	GN 114 230	GN 2/3, unperforated, 40 mm deep, 3 l		
	GN 124 130	GN 1/3, perforated, 40 mm deep, 1.5 l		
	GN 124 230	GN 2/3, perforated, 40 mm deep, 3 l		
Gastronorm roaster, cast aluminium				
	GN 340 230	GN 2/3, height 165 mm, non-stick For ovens with heating element BA 056 115 or BA 058 115 and pull-out system BA 016 or BA 018 (both to be ordered separately) and for Combi-steam ovens with adapter GN 010 330 and pull-out system BA 010 301 (See also page 412).	°	° (without roaster function)
GN-Adapter				
	GN 010 330	Adapter for gastronorm insert		
Glass tray				
	BA 046 117	24 mm deep	•/°	•/°
Wire rack				
	BA 036 105	no opening, with feet	•/°	•/°
	Part No. 435794	for grill tray BA 226 102, angled, no opening		
	Part No. 672921	for grill tray BA 226 105, with opening, and feet	°	°
Grill tray, enamelled				
	BA 226 105	30 mm deep	°	°
Heating element				
	BA 056 115	Necessary accessory for baking stone BA 056 133	°	°
Pizza paddle				
	BS 020 002	Set of 2	°	°
Bean container				
	Part No. 11015223	Bean container with lid		
Cleaning and care				
	CL S10 040	Cleaning cartridges, set of 4		
	Part No. 17002490	Descaling tablets, for combi steam ovens, set of 4		
	Part No. 17000705	Water filter cartridge		
	Part No. 17000706	Water filter cartridge, set of 3		
	Part No. is region-specific	Descaling tablets available via customer service		
	Part No. is region-specific	Cleaning tablets available via customer service		
Water connection				
	GF 111 100	Descaling and neutralising filter, for first installation		
	GF 121 110	Filter cartridge for GF 111 100		
	GZ 010 011	Extension for water inlet and outlet hose		
Vacuuming bags				
	Part No. 00578813	Vacuuming bags, small		
	Part No. 00578814	Vacuuming bags, big		

• Standard.

° Special accessory.



BOP 210/BOP 211

Oven



BSP 270/BSP 271

Combi-steam oven



BSP 260/BSP 261

Combi-steam oven



BSP 250/BSP 251

Combi-steam oven



BSP 220/BSP 221

Steam oven



CMP 250

Fully automatic espresso machine



DVP 221

Vacuuming drawer

◦

◦

◦

◦

◦

◦

◦

◦

•/◦

◦

◦

◦

•/◦

◦

◦

◦

•/◦

◦

◦

•/◦

•/◦

◦

◦

◦

◦

◦

◦

◦

◦

◦

◦

◦

◦

◦

◦

◦

◦

◦

◦

◦

◦

◦

◦

◦

◦

◦

◦

◦

◦

◦

◦

◦

•/◦

•/◦

◦

◦

◦

◦

◦

◦

◦

◦

◦

◦

◦

◦

◦

•/◦

•/◦

Ovens 200 series



Appliance type		Oven	Oven
Side-opening door right-hinged / left-hinged		BOP 250/BOP 251	BOP 220/BOP 221
Full glass door in Gaggenau Anthracite		BOP 250/251 102	BOP 220/221 102
Full glass door in Gaggenau Metallic		BOP 250/251 112	BOP 220/221 112
Full glass door in Gaggenau Silver		BOP 250/251 132	BOP 220/221 132
Dimensions			
Width	(cm)	60	60
Appliance dimensions W x H x D ¹	(mm)	590 x 595 x 547	590 x 595 x 547
Door panel extension from furniture cavity	(mm)	21	21
Niche dimensions W x H x D	(mm)	560 x 590 x 550	560 x 590 x 550
Net weight	(kg)	57	57
Volume / energy efficiency (to EU regulations EN 60350-1, 65/2014 and 66/2014)			
Net volume	(l)	76	76
Number of cooking compartments		1	1
Interior dimensions W x H x D	(mm)	487 x 383 x 405	487 x 383 x 405
Energy efficiency class with eco hot air		A *	A *
Energy Efficiency Index (EEI)		96	96
Energy consumption with top / bottom heat	(kWh)	1.25	1.25
Energy consumption with eco hot air	(kWh)	0.83	0.83
Heat source		electric	electric
Heating methods			
Temperature range	(°C)	30–300	50–300
Hot air / Eco hot air / top + bottom heat		•/•/•	•/•/•
Top heat / bottom heat / hot air + bottom heat		•/•/•	•/•/•
Full surface grill + circulated air		•	•
Full surface grill		•	•
Compact grill		•	–
Baking stone function		•	•
Roaster function		•	–
Dough proofing / defrosting / keeping warm		•/•/–	–/–/–
Handling			
TFT touch display		•	•
Controls at the top / at the bottom		•/–	•/–
Clear text display	(No. of languages)	44	44
Individual recipes		50	50
Door opening angle		110°	110°
Features			
Electronic temperature control		•	•
Three-point core temperature probe		•	–
Automatic programmes		•	–
Baking stone socket		•	•
Roasting function		•	–
Actual temperature display		•	•
Rapid heating		•	•
Cooking time, cooking time end, timer, stopwatch		•	•
Long-term timer		•	•
Halogen light on the top	(W)	60	60
Tray levels	(No.)	4	4
Digital services (Home Connect) either via LAN or wireless via WiFi.		• ³	• ³
Accessories			
Enamelled baking tray		1	1
Size of largest baking tray	(cm ²)	1.200	1.200
Wire rack		1	1
Enamelled grill tray / wire rack for grill tray		BA 226 105 ² /672 921 ²	BA 226 105 ² /672 921 ²
Glass tray		1	1
Safety			
Thermally insulated door with multiple glazing		5-fold	5-fold
Child lock / safety shut-off		•/•	•/•
Cooled housing with temperature protection		•	•
Cleaning			
Pyrolytic system		•	•
Catalytic coating on back wall / ceiling		–	–
Gaggenau enamel		•	•
Heated air cleaning catalyser		•	•
Grease filter in front of hot air fan		–	–
Connection			
Total connected load	(kW)	3.7	3.7

• Standard. – Not available.

¹ Appliance depth: the immersion depth of the appliance in the niche.

² Special accessory, see pages 78–81.

³ The use of the Home Connect functionality depends on the Home Connect services, which are not available in every country.

* Energy efficiency class: at a range of energy efficiency classes from A+++ to D.



Oven

BOP 210/BOP 211
 BOP 210/211 102
 BOP 210/211 112
 BOP 210/211 132

60
 590 x 595 x 547
 21
 560 x 590 x 550
 53

76
 1
 487 x 383 x 405



96
 1.25
 0.83
 electric

50-300
 •/•/•
 •/•/•
 •
 •
 -
 •
 -
 - / - / -

•
 •/-
 44
 50
 110°

•
 -
 -
 •
 -
 •
 •
 •
 •
 •
 60
 4
 •³

1
 1.350
 1
 1/-
 BA 046 115²

3-fold
 •/•
 •

-
 664 248² / 664 048²
 •
 •
 -

3.7

Combi-steam ovens and steam ovens 200 series



Appliance type		Combi-steam oven	Combi-steam oven
Side-opening door right-hinged / left-hinged		BSP 270/BSP 271	BSP 260/BSP 261
Full glass door in Gaggenau Anthracite		BSP 270/BSP 271 101	BSP 260/BSP 261 101
Full glass door in Gaggenau Metallic		BSP 270/BSP 271 111	BSP 260/BSP 261 111
Full glass door in Gaggenau Silver		BSP 270/BSP 271 131	BSP 260/BSP 261 131
Dimensions			
Width	(cm)		
Appliance dimensions W x H x D ¹	(mm)	590 x 455 x 540	590 x 455 x 540
Door panel extension from furniture cavity	(mm)	21	21
Niche dimensions W x H x D	(mm)	560 x 450 x 550	560 x 450 x 550
Net weight	(kg)	36	34
Volume / energy efficiency (to EU regulations EN 60350-1, 65/2014 and 66/2014)			
Net volume	(l)	50	50
Number of cooking compartments		1	1
Interior dimensions W x H x D	(mm)	501 x 246 x 406	501 x 248 x 406
Energy efficiency class with hot air + 30 % humidity		A *	A *
Energy Efficiency Index (EEI)		94.7	94.7
Energy consumption with hot air + 30 % humidity	(kWh)	0.72	0.72
Heat source		electric	electric
Heating methods			
Temperature range	(°C)	30 – 230	30 – 230
Hot air + 100 % humidity		•	•
Hot air + 80 % humidity		•	•
Hot air + 60 % humidity		•	•
Hot air + 30 % humidity		•	•
Hot air + 0 % humidity		•	•
100 % humidity		–	–
Low temperature cooking		•	•
Low temperature steaming		–	–
Sous-vide cooking		•	•
Full surface grill level 1 + humidity		•	•
Full surface grill level 2 + humidity		•	•
Full surface grill + Umluft		•	•
Dough proofing		•	•
Defrosting		•	•
Regenerating		•	•
Handling			
TFT touch display		•	•
Controls at the top / at the bottom		•/–	•/–
Clear text display	(No. of languages)	44	44
Individual recipes		50	50
Door opening angle		110°	110°
Features			
Steaming without pressure		•	•
Electronic temperature control		•	•
Full surface grill behind glass ceramic		2000	2000
Three-Point core temperature probe		•	•
Automatic programmes		•	•
Actual temperature display		•	•
Cooking time, cooking time end, timer, stopwatch		•	•
Long-term timer		•	•
Electronic boiling point detection		•	•
Water tank capacity / water level warning	(l)	1.7/•	1.7/•
LED light on the side	(W)	10	10
Tray levels / stainless steel cooking interior	(No.)	3 / •	3 / •
Digital services (Home Connect) either via LAN or wireless via WiFi. ³		•	•
Accessories			
Size of largest baking tray	(cm ²)	810	810
Wire rack		1	1
Cooking container, stainless steel, 40 mm, perforated / unperforated		1/1	1/1
Cleaning cartridge		4	–
Descaling tablets		Part No. 17002490	Part No. 17002490
Safety			
Thermally insulated door with multiple glazing		3-fold	3-fold
Child lock / safety shut-off		•/•	•/•
Cooled housing with temperature protection		•	•
Cleaning			
Cleaning aid / drying programme		•/•	•/•
Descaling aid / descaling programme		–/•	–/•
Automatic drying of the cavity at the end of the cooking process.		•	•
Grease filter in front of hot-air fan		–	•
Connection			
Total connected load	(kW)	3.15	3.15

• Standard. – Not available.

¹ Appliance depth: the immersion depth of the appliance in the niche. ² Special accessory, see pages 78 - 81.

³ The use of the Home Connect functionality depends on the Home Connect services, which are not available in every country.

* Energy efficiency class: at a range of energy efficiency classes from A+++ to D.



Combi-steam oven

BSP 250/BSP 251
 BSP 250/BSP 251 101
 BSP 250/BSP 251 111
 BSP 250/BSP 251 131

Steam oven

BSP 220/BSP 221
 BSP 220/BSP 221 101
 BSP 220/BSP 221 111
 BSP 220/BSP 221 131

60
 590 x 455 x 540
 21
 560 x 450 x 550
 36

60
 590 x 455 x 540
 21
 560 x 450 x 550
 34

50
 1
 501 x 248 x 406

59
 1
 473 x 278 x 446

A
 94.7
 0.72
 electric

30 – 230	30 – 100
•	–
•	–
•	–
•	–
•	–
–	•
•	–
–	•
•	•
•	–
•	–
•	–
•	•
•	•

•	•
•/–	•/–
44	44
50	–
110°	110°

•	•
•	•
2000	–
•	–
•	–
•	•
•	•
•	–
•	•
1.7/•	1.7/•
10	10
3/•	3/•
•	•

810	810
1	1
1/1	1/1
–	–
Part No. 17002490	Part No. 17002490

3-fold	3-fold
•/•	•/•
•	•

•/•	•/–
–/•	–/•
•	•
•	–

3.15	2.75
------	------

Combi-microwave ovens and microwaves 200 series



Appliance type		Combi-microwave oven	Microwave
Side-opening door right-hinged / left-hinged		BMP 250/BMP 251	BMP 224/BM 225
Full glass door in Gaggenau Anthracite		BMP 250/251 100	BMP 224/225 100
Full glass door in Gaggenau Metallic		BMP 250/251 110	BMP 224/225 110
Full glass door in Gaggenau Silver		BMP 250/251 130	BMP 224/225 130
Dimensions			
Width	(cm)	60	60
Appliance dimensions W x H x D ¹	(mm)	590 x 455 x 538	590 x 382 x 300
Door panel extension from furniture cavity	(mm)	21	21
Niche dimensions W x H x D	(mm)	560 x 450 x 550	560 x 380 x 320
			560 x 362 x 300 (wall cabinet)
Net weight	(kg)	41	20
Volume			
Capacity	(l)	36	21
Interior dimensions W x H x D	(mm)	445 x 236 x 348	350 x 220 x 270
Heating methods / Programmes			
Maximum microwave output	(W)	1.000	900
Microwave output levels	(No.)	5	5
Hot air with temperature range	(°C)	40, 100–250	–
Full surface grill + hot air with temperature range	(°C)	100–250	–
Full surface grill + circulated air with temperature range	(°C)	100–250	–
Full surface grill as quartz grill with levels of intensity	(No.)	3	3
Maximum grill output	(W)	2.000	1.300
Hot air output	(W)	1.950	–
Maximum microwave output for combination with grill and oven	(W)	600	360
Sequential operation of up to 5 modes incl. programming of combined operation and rest time		•	•
Automatic weight feature	(No.)	15	10
Handling			
TFT touch display		•	•
Controls at the top / at the bottom		•/–	–/•
Automatic door opening		•	•
Clear text display	(No. of languages)	25	25
Individual recipes		50	50
Door opening angle		110°	110°
Features			
Electronic temperature control		•	•
Actual temperature display		•	–
Rapid heating		•	–
Innowave		•	•
Cooking time, switch-off time, short-term timer, stop watch		•/•/•/•	•/–/–/–
Long-term timer		•	–
Interior lighting, side	(W)	60	25
Rack levels	(No.)	4	–
Accessories			
Glass tray		•	•
Wire rack		•	•
Glass rod		•	•
Safety			
Thermally insulated door with multiple glazing		•	•
Child lock / safety shut-off		•/•	–/•
Triple door lock		•	•
Cooled housing with temperature protection		•	•
Cleaning			
Catalytic special enamelling at interior back wall		•	–
Stainless steel interior with ceramic base		•	•
Connection			
Total connected load	(kW)	3.1	1.99

• Standard. – Not available.

¹ Appliance depth: the immersion depth of the appliance in the niche.



Appliance type		Fully automatic espresso machine
Glass front in Gaggenau Anthracite		CMP 250 102
Glass front in Gaggenau Metallic		CMP 250 112
Glass front in Gaggenau Silver		CMP 250 132
Dimensions		
Width	(cm)	60
Appliance dimensions W x H x D ¹	(mm)	590 x 455 x 426
Door panel extension from furniture cavity	(mm)	21
Niche dimensions W x H x D	(mm)	560 x 450 x 550
Net weight	(kg)	20
Typ of beverage		
		Ristretto / 2 x Ristretto
		Espresso / 2 x Espresso
		Espresso Macchiato / 2 x Espresso Macchiato
		Coffee / 2 x coffee
		Americano / 2 x Americano
		Caffe Latte / 2 x Caffe Latte
		Latte Macchiato / 2 x Latte Macchiato
		Cappuccino / 2 x Cappuccino
		Flat White / 2 x Flat White
		Milk froth / 2 x Milk froth
		Warm milk / 2 x Warm milk
		Hot water / 2 x Hot water
Handling		
TFT touch display		•
Controls at the top		•
Automatic door opening		
Clear text display	(No. of languages)	25
Beverages can be personalised and memorised	(No.)	8
Beverage size settings	(No.)	3
Coffee strength levels	(No.)	8
Coffee temperature levels	(No.)	3
Hot water temperature levels	(°C)	
Coffee-milk ratio levels		•
Height adjustable coffee dispenser up to	(cm)	15
Programmable basic settings		
- Lighting scenarios	(No.)	7
- Capacity unit	(ml/fl.oz.)	•
- Adjustability of dispensing per type and size of beverage to match the cup size		•
- Standby after	(min, h)	5 min to 12 h
- Water hardness	(No. of levels)	4, water-softening system
- Water filter		•
Features		
Aroma brewing technology		•
Grinding unit with ceramic discs		•
Automatic adjustment of ground coffee quantity		•
Continuous flow heater		•
Pump pressure	(bar)	19
Integrated milk system		•
Insulated milk container	(l)	0.5
Bean container	(g)	500
Separate container for second ground coffee type		•
Grinding level control		•
Volume of adjustable brewing chamber	(g)	8 to 12
Double grinding and brewing cycles for extra intensity for one beverage		•
Double grinding and brewing cycles for two beverages		•
Removable water tank	(l)	2.4
Water filter cartridge for water tank		1
Single portion cleaning		•
Electronic water filter exchange indicator		•
Electronic fill level control for milk, water and coffee beans		•
Electronic fill level control for drip tray and coffee residues container		•
Integrated LED lighting		•
Safety		
Child lock		•
Cleaning		
Fully automatic rinse programme when switching on/off		•/•
Automatic quick rinsing of milk system		•
Automatic cleaning and descaling programme		•
Automatic cleaning programme		•
Automatic descaling programme		•
Removable brewing unit		•
Coffee residue container and drip tray removable and dishwasher-safe		•
Beverage dispenser removable and dishwasher-safe		•
Emptying programme to prepare the appliance for holiday or transportation		•
Empty-grinding function, if using a new type of beans		•
Connection		
Total connected load	(kW)	1.6

• Standard. – Not available.

¹ Appliance depth: the immersion depth of the appliance in the niche.

Vacuuming drawers 200 series



Appliance type		Vacuuming drawer
Glass front in Gaggenau Anthracite		DVP 221 100
Glass front in Gaggenau Metallic		DVP 221 110
Glass front in Gaggenau Silver		DVP 221 130
Dimensions		
Width	(cm)	60
Appliance dimensions W x H x D ¹	(mm)	590 x 140 x 542
Door panel extension from furniture cavity	(mm)	21
Niche dimensions W x H x D	(mm)	560 x 140 x 550
Net weight	(kg)	30
Volume		
Net volume	(l)	7
Interior dimensions W x H x D	(mm)	210 x 95 x 275
Maximum size of vacuuming bags W x L	(mm)	240 x 350
Usage		
Vacuuming levels		3, max. 99 %
Heat-sealing levels		3
Vacuuming of bags and containers		•
Vacuuming of vacuuming containers and bottles		•
Vacuuming of liquids		•
Drying program for vacuuming pump		•
Warming function		•
Handling		
Sensor Control		•
Handleless drawer		•
Recessed grip		–
Push-to-open system		•
Cushioned closing system		–
Features		
Stainless steel vacuuming chamber		•
Maximum load	(kg)	10
Applicable height	(mm)	80
Safety glass cover		•
Sealing bar, non-stick, removable		•
Raised vacuuming platform		•
Connection with tube for vacuuming outside the chamber		•
Utility space in vacuuming chamber, W x L	(mm)	210 x 275
Membrane avoiding reflow of liquids during external vacuuming		•
Vacuuming bags, small, 180 mm x 280 mm	(pcs.)	50
Vacuuming bags, large, 240 mm x 350 mm	(pcs.)	50
Plug for vacuuming bottles	(pcs.)	3
Adaptor for bottle plugs		•
Connection		
Total connected load	(kW)	0.32

• Standard. – Not available.

¹ Appliance depth: the immersion depth of the appliance in the niche.



Appliance type	Culinary warming drawer	Culinary warming drawer
Glass front in Gaggenau Anthracite	WSP 221 102	WSP 222 102
Glass front in Gaggenau Metallic	WSP 221 112	WSP 222 112
Glass front in Gaggenau Silver	WSP 221 132	WSP 222 132
Dimensions		
Width	(cm) 60	60
Appliance dimensions W x H x D ¹	(mm) 590 x 140 x 528	590 x 290 x 528
Door panel extension from furniture cavity	(mm) 21	21
Niche dimensions W x H x D	(mm) 560 x 140 x 550	560 x 290 x 550
Net weight	(kg) 17	21
Volume		
Net volume	(l) 20	54
Interior dimensions W x H x D	(mm) 547 x 91 x 410	547 x 241 x 410
Number of table settings	(No.) 6	12
Heating methods		
Defrosting of meals / proving of yeast dough	•	•
Preheating of small beverage containers	•	•
Keeping meals warm / slow cooking meals	•	•
Warming ovenware	•	•
Low temperature cooking	•	•
Temperature range 30°C to 80°C (temperature levels)	6	6
Further heating methods via App	•	•
Handling		
Rotary knob	•	•
Status display, visible in the glass front	•	•
Handleless drawer	•	•
Push-to-open system	•	•
Cushioned closing system	-	-
Features		
Interior light	-	-
Maximum load	(kg) 25	25
Stainless steel interior with glass bottom	•	•
Fan for even heat distribution	•	•
Connection		
Total connected load	(kW) 0.82	0.82

• Standard. – Not available.















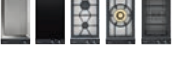

¹ Appliance depth: the immersion depth of the appliance in the niche.















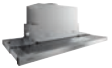

The Vario cooktops

Vario cooktops 400 series	94
Cut-out dimensions for appliance combinations in the 400 series	130
Vario cooktops 200 series	136
Cut-out dimensions for appliance combinations in the 200 series	144
Accessories special accessories	146
Technical specifications	148

Recommended Cooktop Ventilation Combinations

✓ : aesthetically and technically recommended combination — : not recommended  : cooktop based ventilation control possible.								
Product type	Picture	VIB		AC 400 width depends on configuration	AC 250 121 width 120 cm	AW 442 width 120 cm	AW 240 191 width 90 cm	AI 240 191 width 90 cm
	Maximum width for cooktops combinations For integrated induction see dedicated pages.				100 cm 130 cm with fume collector	100 cm	80 cm	80 cm
Vario Teppan Yaki 400 serie Vario gas cooktop 400 series Vario electric grill 400 series		VP 414 / VG4.. / VR 414	40 cm	✓	✓	✓	—	—
Vario induction cooktop 400 series		VI4..	40 cm	✓	✓ 	✓	—	—
Vario induction cooktop 400 series		VI 462	60 cm	✓	✓ 	✓	—	—
Vario induction cooktop 400 series		VI 462	80 cm	✓	✓ 	✓	—	—
Vario induction cooktop 400 series		VI 492	90 cm	✓	✓ 	✓	—	—
Vario gas cooktop 400 series Gas cooktop 400 series		VG 491 / CG 492	90 cm	✓	✓	✓	—	—
Vario Teppan Yaki 200 series Vario flex induction cooktop 200 series Vario gas cooktop 200 series Vario electric grill 200 series		VP2.. / VI2.. / VR2.. / VG2.. / VR 230	30 cm	✓	✓	✓	—	—
Vario flex induction cooktop 200 series		VI 242	40 cm	✓	✓	✓	—	—
Vario flex induction cooktop 200 series Vario gas cooktop 200 series		VI 262 / VG 264	60 cm	✓	✓	✓	—	—
Integrated induction modules 400 series		CU 42..	21 cm 28 cm	✓	✓	—	—	—
Full surface induction cooktop 400 series with frame		CX 482 111	80 cm	✓	✓ 	✓	✓ 	—
Full surface induction cooktop 400 series frameless		CX 482 101	80 cm	✓	✓ 	✓	✓ 	—
Full surface induction cooktop 400 series		CX 492	90 cm	✓	✓ 	✓	—	—
Flex induction cooktop 200 series		CI 261	60 cm	✓	✓	✓	✓	✓
Flex induction cooktop 200 series		CI 262	60 cm	✓	✓ 	✓	✓ 	✓ 
Flex induction cooktop 200 series		CI 272	70 cm	✓	✓ 	✓	✓ 	✓ 
Flex induction cooktop 200 series		CI 282 / CI 283	80 cm	✓	✓ 	✓	✓ 	—
Flex induction cooktop 200 series		CI 292	90 cm	✓	✓ 	✓	—	—
Gas cooktop 200 series		CG 261	60 cm	✓	✓	✓	—	—
Gas cooktop 200 series		CG 291	90 cm	✓	✓	✓	—	—
Gas cooktop 200 series		VG 295	90 cm	✓	✓	✓	—	—
Glass ceramic cooktop 200 series		CE 261	60 cm	✓	✓	✓	✓	✓
Glass ceramic cooktop 200 series		CE 291	90 cm	✓	✓	✓	—	—

										
AL 400 122 width 120 cm	AL 400 192 width 90 cm	AL 200 180 width 80 cm	AL 200 190 width 90 cm	VL 414 width 15,5 cm	VL 200 width 15 cm	AF 210 192 width 90 cm	AF 210 162 width 60 cm	AC 200 191 width 86 cm	AC 200 181 width 70 cm	AC 200 161 width 52 cm
120 cm	90 cm					90 cm	60 cm	90 cm	70 cm	60 cm
✓	✓	-	-	✓	-	✓	✓	✓	✓	✓
✓	✓	-	-	✓ 	-	✓	✓	✓	✓	✓
-	-	-	-	✓	-	✓	✓	✓	✓	✓
✓	-	✓ 	-	✓	-	✓	-	✓	-	-
-	✓	-	✓ 	-	-	✓	-	✓	-	-
-	✓	-	-	-	-	✓	-	✓	-	-
-	-	-	-	-	✓	✓	✓	✓	✓	✓
-	-	-	-	-	✓	✓	✓	✓	✓	✓
-	-	-	-	-	✓	✓	✓	✓	✓	✓
-	-	-	-	-	-	-	-	-	-	-
✓	-	✓ 	-	-	-	✓	-	✓	-	-
-	-	✓ 	-	-	-	✓	-	✓	-	-
-	✓	-	✓ 	-	-	✓	-	✓	-	-
-	-	-	-	-	-	✓	✓	✓	✓	✓
-	-	-	-	-	-	✓	✓	✓	✓	✓
-	-	-	-	-	-	✓	-	✓	✓	-
-	-	✓ 	-	-	-	✓	-	✓	-	-
-	✓	-	✓ 	-	-	✓	-	✓	-	-
-	-	-	-	-	-	✓	✓	✓	✓	✓
-	-	-	-	-	-	✓	-	✓	✓	-
-	-	-	-	-	-	✓	✓	✓	✓	✓
-	-	-	-	-	-	✓	-	✓	-	-
✓	✓	-	-	-	-	✓	✓	✓	✓	✓
✓	✓	-	-	-	-	✓	-	✓	-	-



CX 492 111

Black glass ceramic
Stainless steel frame
Width 90 cm

Included in the price

1 wireless cooking sensor for temperature regulation

Installation accessories

VA 420 004

Connection strip for combination with other Vario appliances of the 400 series for flush mounting

VA 420 010

Connection strip for combination with other Vario appliances of the 400 series for surface mounting

Special accessories

CA 060 300

Cooking sensor for temperature regulation within pots

GN 232 110

Teppan Yaki plate made of multi ply material,
GN 1/1

For full surface induction cooktops.

GN 232 230

Teppan Yaki plate made of multi ply material,
GN 2/3

For full surface induction cooktops.

Full surface induction cooktop 400 series

CX 492

- One single big cooking surface
- Free positioning of cookware
- All sizes and formats of cookware can be used
- TFT touch display for an intuitive control of all functions
- Cooking sensor function for temperature control in pots
- Professional cooking functions
- Max. power output for big cookware of up to 5.5 kW
- Precision crafted 3 mm stainless steel
- For surface mounting with a visible edge or for flush mounting
- Can be combined perfectly with other Vario appliances of the 400 series

Cooking zones

One unique cooking surface of 3200 cm².
Up to 6 items of cookware can be placed simultaneously on the cooktop.

Handling

Easy to use colour graphic TFT touch display with use indications.
Electronic power control in 17 output levels.

Features

Cooking sensor function.
Professional cooking function.
Dynamic cooking function.
Teppan Yaki function.
Booster function for pots.
Booster function for pans.
Keep warm function.
Individual pot detection.
Cooking timer for each cooking position.
Stopwatch.
Short-term timer.
Information key with use indicators.
Power management.

Selected digital services

(Home Connect)

Cooktop-based ventilation control (with suitable hood).
Remote monitoring.
Remote diagnostics.

Please read additional information on Home Connect on page 411.

Safety

Main switch.
Residual heat indication.
Child lock.
Safety shut-off.
Pause function.

Planning notes

Depending on the type of installation (surface-mounted or flush-mounted), the specific definition of the cut-out must be observed.

If combining several Vario appliances of the 400 series, select combinations with or without appliance cover, and a connection strip VA 420 must be placed between the appliances. Depending on the type of installation, the corresponding connection strip must be provided.

The bearing capacity and stability, in the case of thinner worktops in particular, must be supported using suitable substructures. Take into account the appliance weight and additional loads. Additional instructions for flush mounting: Installation is possible in worktops made of stone, synthetics or solid wood. Heat resistance and watertight sealing of the cut edges must be observed. Concerning other materials please consult the worktop manufacturer. The groove must be continuous and even, so that uniform placing of the appliance on the gasket is ensured. Do not use discontinuous lining. The joint width may vary due to size tolerances of the combinations and of the worktop cut-out.

Please read additional planning notes on page 130 and 132.

If installing several appliances in individual cut-outs allow for a division bar of minimum 50 mm between the individual cut-outs.
Operates with magnetic (induction) iron pots and pans only. For an optimal heat distribution, the use of sandwich bottom cookware is recommended. The wok pan WP 400 001 cannot be used with this appliance.
Appliance can be snapped into the worktop from above.
Appliance weight: approx. 31 kg.

Please read the installation details regarding air ducting on page 210.

Connection

Total connected load 7.4 kW.
Connecting cable 1.5 m without plug.
Power consumption standby/display off 0.5 W.
Power consumption standby/network 2.0 W.
Please check the user manual for how to switch off the WiFi module.

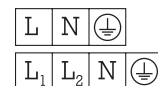

Installation of the cooktop; surface mounting

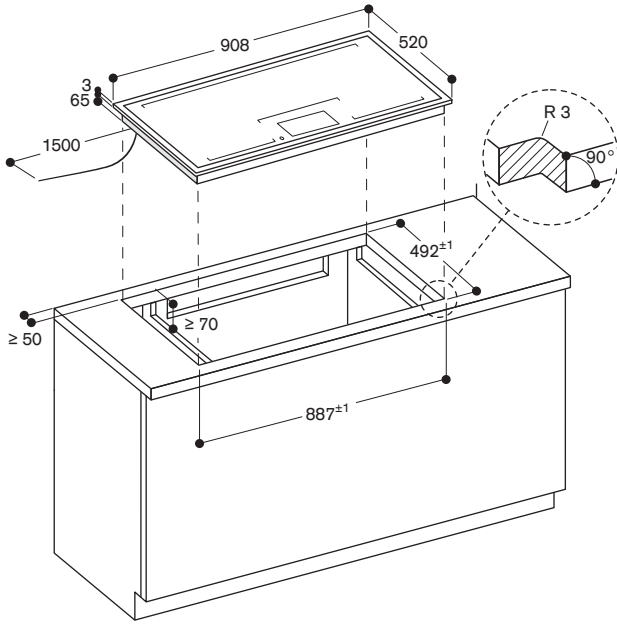

measurements in mm

Installation of the cooktop; flush mounting

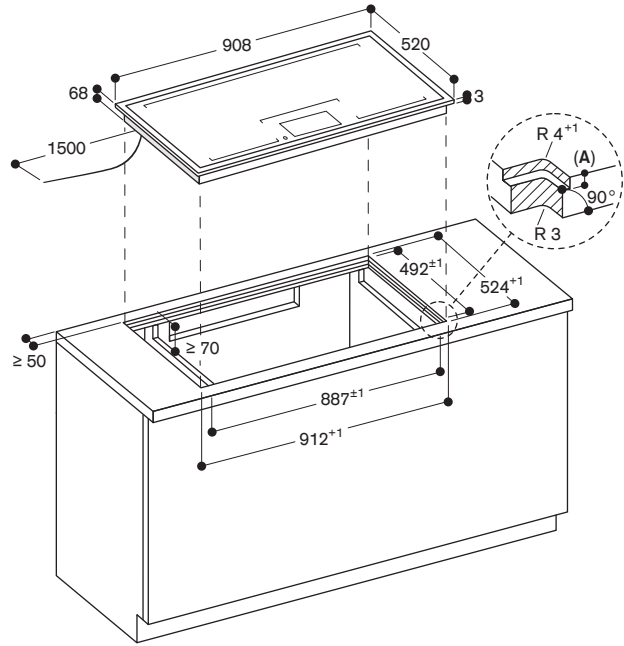

A: 3.5^{±0.5}

measurements in mm

View from above

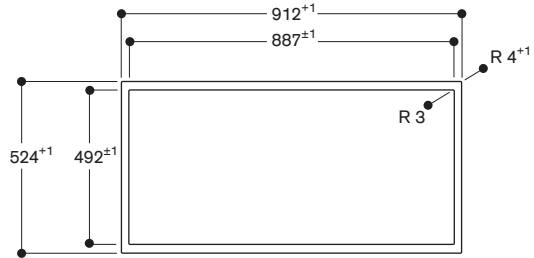

measurements in mm

Longitudinal section

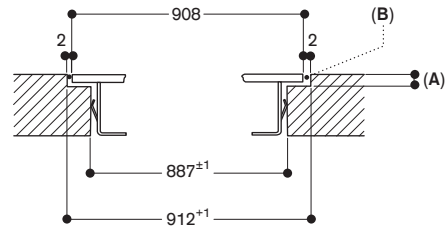

A: 3.5^{±0.5}

B: Fill with silicone

measurements in mm

Cross-section

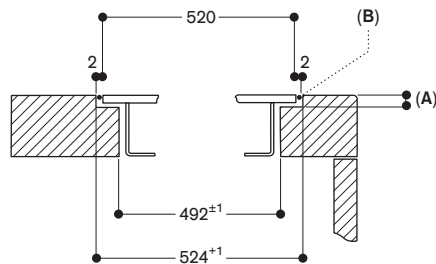

A: 3.5^{±0.5}

B: Fill with silicone

measurements in mm



CX 482 111

Black glass ceramic
Stainless steel frame
Width 80 cm

Included in the price

1 wireless cooking sensor for temperature regulation

Installation accessories

VA 420 004

Connection strip for combination with other Vario appliances of the 400 series for flush mounting

VA 420 010

Connection strip for combination with other Vario appliances of the 400 series for surface mounting

Special accessories

CA 060 300

Cooking sensor for temperature regulation within pots

GN 232 110

Teppan Yaki plate made of multi ply material,
GN 1/1

For full surface induction cooktops.

GN 232 230

Teppan Yaki plate made of multi ply material,
GN 2/3

For full surface induction cooktops.

Full surface induction cooktop 400 series

CX 482

- One single big cooking surface
- Free positioning of cookware
- All sizes and formats of cookware can be used
- TFT touch display for an intuitive control of all functions
- Cooking sensor function for temperature control in pots
- Professional cooking functions
- Max. power output for big cookware of up to 5.5 kW
- Precision crafted 3 mm stainless steel
- For surface mounting with a visible edge or for flush mounting
- Can be combined perfectly with other Vario appliances of the 400 series

Cooking zones

One unique cooking surface of 2750 cm².
Up to 5 items of cookware can be placed simultaneously on the cooktop.

Handling

Easy to use colour graphic TFT touch display with use indications.
Electronic power control in 17 output levels.

Features

Cooking sensor function.
Professional cooking function.
Dynamic cooking function.
Teppan Yaki function.
Booster function for pots.
Booster function for pans.
Keep warm function.
Individual pot detection.
Cooking timer for each cooking position.
Stopwatch.
Short-term timer.
Information key with use indicators.
Power management.

Selected digital services (Home Connect)

Cooktop-based ventilation control (with suitable hood).
Remote monitoring.
Remote diagnostics.

Please read additional information on Home Connect on page 411.

Safety

Main switch.
Residual heat indication.
Child lock.
Safety shut-off.
Pause function.

Planning notes

Depending on the type of installation (surface-mounted or flush-mounted), the specific definition of the cut-out must be observed.
If combining several Vario appliances of the 400 series, select combinations with or without appliance cover, and a connection strip VA 420 must be placed between the appliances.
Depending on the type of installation, the corresponding connection strip must be provided.

The bearing capacity and stability, in the case of thinner worktops in particular, must be supported using suitable substructures. Take into account the appliance weight and additional loads. Additional instructions for flush mounting: Installation is possible in worktops made of stone, synthetics or solid wood. Heat resistance and watertight sealing of the cut edges must be observed. Concerning other materials please consult the worktop manufacturer. The groove must be continuous and even, so that uniform placing of the appliance on the gasket is ensured. Do not use discontinuous lining. The joint width may vary due to size tolerances of the combinations and of the worktop cut-out.

Please read additional planning notes on page 130 and 132.

If installing several appliances in individual cut-outs allow for a division bar of minimum 50 mm between the individual cut-outs.
Operates with magnetic (induction) iron pots and pans only. For an optimal heat distribution, the use of sandwich bottom cookware is recommended. The wok pan WP 400 001 cannot be used with this appliance.
Appliance can be snapped into the worktop from above.
Appliance weight: approx. 27 kg.

Please read the installation details regarding air ducting on page 210.

Connection

Total connected load 7.4 kW.
Connecting cable 1.5 m without plug.
Power consumption standby/display off 0.5 W.
Power consumption standby/network 2.0 W.
Please check the user manual for how to switch off the WiFi module.

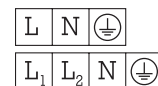

Installation of the cooktop; surface mounting

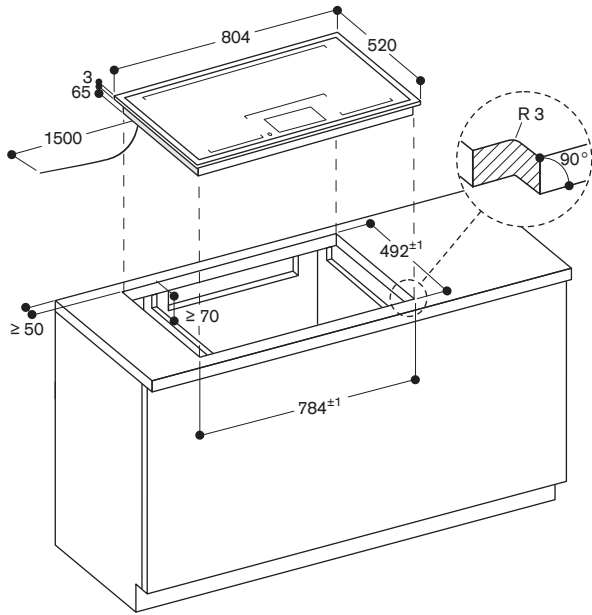

measurements in mm

Installation of the cooktop; flush mounting

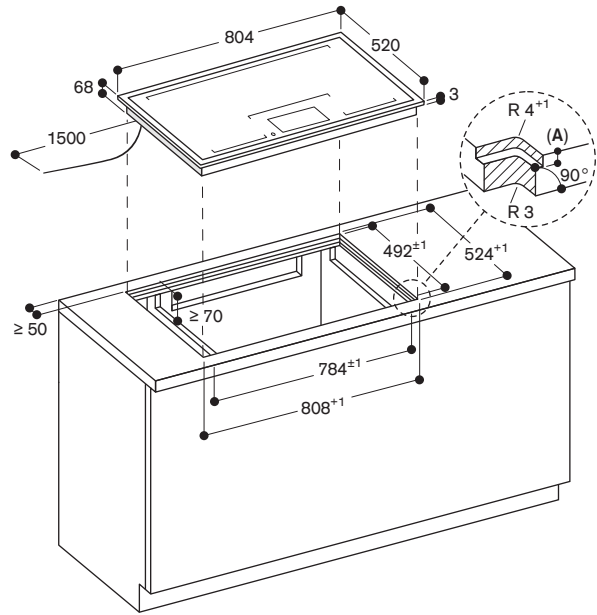

A: 3.5^{0.5}

measurements in mm

View from above

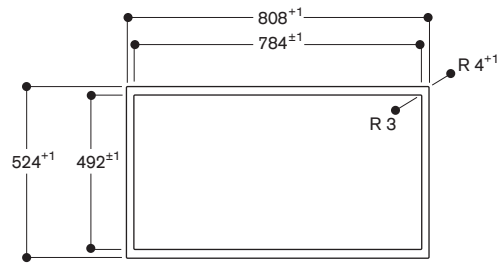

measurements in mm

Longitudinal section

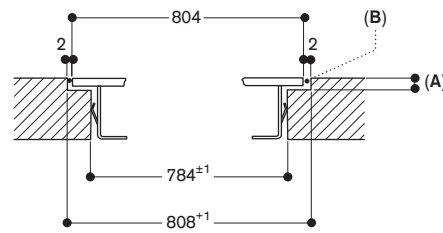

A: 3.5^{0.5}

B: Fill with silicone

measurements in mm

Cross-section

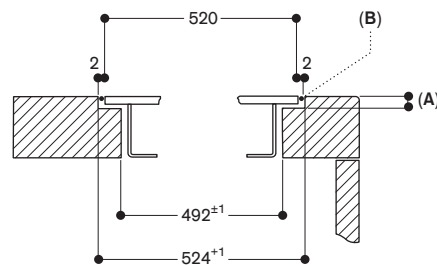

A: 3.5^{0.5}

B: Fill with silicone

measurements in mm



VI 492 105

Frameless

Width 90 cm

Knobs need to be ordered separately

Necessary installation accessories

CKI 450 010

Stainless steel knobs 400 series for VI 492

Electronic control

Set of 5 knobs

CKI 450 000

Black knobs 400 series for VI 492

Electronic control

Set of 5 knobs

Installation accessories

VA 420 004

Connection strip for combination with other Vario appliances of the 400 series for flush mounting

Special accessories

CA 051 301

Teppan Yaki plate made of multi ply material

For flex induction cooktop.

CA 052 300

Griddle plate in cast aluminum

Non-stick.

For flex induction cooktop.

CA 050 300

Flex Pan set, 3 pcs.

Non-stick coating.

For flex induction cooktop.

CA 055 300

Flex Pan large

Non-stick coating.

For flex induction cooktop.

WP 400 001

Wok pan made of multiple-layer material

With round bottom and handle, ø36 cm, 6 litres, height 10 cm.

WZ 400 000

Wok attachment for wok pan

Only for Vario induction cooktops.

Vario flex induction cooktop 400 series

VI 492

- Flex function for combining the rectangular cooking areas
- Free positioning of cookware inside combined cooking areas
- Large cooking zone for pots up to ø32 cm
- Ideal for the original wok pan with round bottom, with wok ring
- Solid stainless steel knob, also selectable with black robust finishing, for precise control and personalisation
- Frameless for flush mounting
- Can be combined perfectly with other Vario appliances of the 400 series

Cooking zones

2 flex induction cooking areas 23x20 cm (2200 W, with booster 3700 W), linked together 23x40 cm (3300 W, with booster 3700 W).

2 flex induction cooking areas 23x20 cm (2200 W, with booster 3700 W), linked together 23x40 cm (3300 W, with booster 3700 W).

1 induction cooking zone ø21 cm (2200 W, with booster 3700 W), automatically switches to ø26 cm (2600 W, with booster 3700 W) and to ø32 cm (3300 W, with booster 3700 W).

Handling

Control knobs with illuminated ring, cooking zone and output level markings. Electronic power control in 12 output levels.

User friendly control with bicoloured display (white / orange).

Features

Flex function for rectangular cooking areas.

Frying sensor function.

Booster function.

Stopwatch.

Short-term timer.

Options menu.

Power management.

Selected digital services (Home Connect)

Cooktop-based ventilation control (with suitable hood).

Remote monitoring.

Remote diagnostics.

Please read additional information on Home Connect on page 411.

Safety

Operation indicator.

Pot detection.

2-stage residual heat indication.

Safety shut-off.

Planning notes

The horizontal positioning of the knobs may be aligned with the specific cooking areas.

The drawing "Installation of the control knob" must be observed if the panel is more than 23 mm thick (there must be a recess at the rear).

The bearing capacity and stability, in the case of thinner worktops in particular, must be supported using suitable substructures. Take into account the appliance weight and additional loads.

Installation is possible in worktops made of stone, synthetics or solid wood. Heat resistance and watertight sealing of the cut edges must be observed. Concerning other materials please consult the worktop manufacturer. The groove must be continuous and even, so that uniform placing of the appliance on the gasket is ensured. Do not use discontinuous lining. The joint width may vary due to size tolerances of the combinations and of the worktop cut-out.

Please read additional planning notes on page 130 and 132.

If installing several appliances in individual cut-outs allow for a division bar of minimum 50 mm between the individual cut-outs.

Operates with magnetic (induction) iron pots and pans only. For an optimal heat distribution, the use of sandwich bottom cookware is recommended.

Special accessories

(please order as spare parts):

Part No. 17006018

Frying sensor pan, ø 20 cm

Part No. 17006184

Frying sensor pan, ø 24 cm

Part No. 17006185

Frying sensor pan, ø 28 cm

Part No. 17006019

Frying sensor pan, ø 32 cm

Appliance can be snapped into the worktop from above.

Appliance weight: approx. 23 kg.

Please read the installation details regarding air ducting on page 210.

Connection

Total connected load 11.1 kW.

Connecting cable 1.5 m without plug.

Connecting cables 0.3 m and 1 m for control knobs.

Power consumption standby/display off 0.5 W.

Power consumption standby/network 1.9 W.

Please check the user manual for how to switch off the WiFi module.

Length of connection cable, water in- and outlet see detailed drawing on page 99.

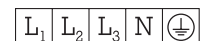

Installation of the cooktop; flush mounting

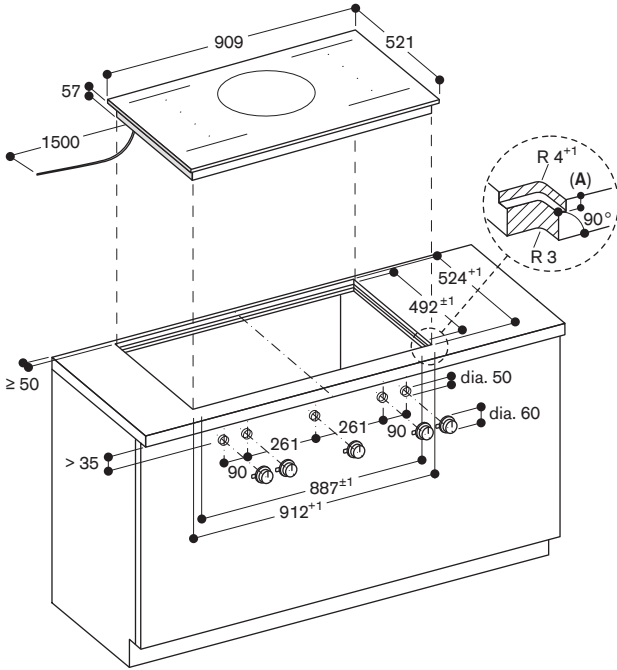

A: 6.5^{+0.5}
 measurements in mm

Installation of the control knob

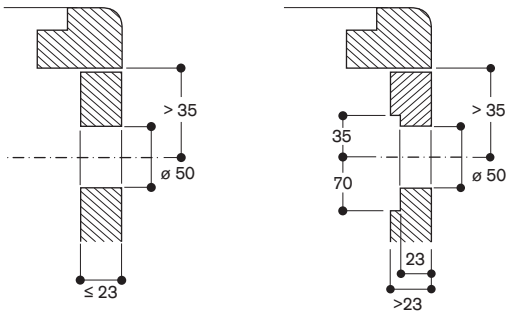

measurements in mm

View from above

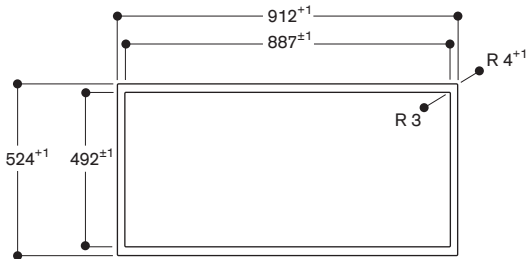

measurements in mm

Longitudinal section

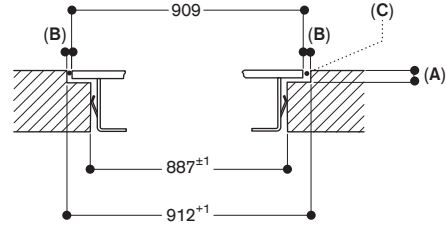

A: 6.5^{+0.5}
 B: 1.5
 C: Fill with silicone

measurements in mm

Cross-section

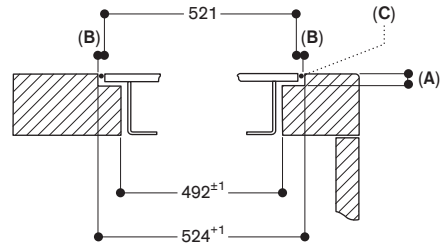

A: 6.5^{+0.5}
 B: 1.5
 C: Fill with silicone

measurements in mm



VI 492 115

Stainless steel frame

Width 90 cm

Knobs need to be ordered separately

Necessary installation accessories

CKI 450 010

Stainless steel knobs 400 series for VI 492

Electronic control

Set of 5 knobs

CKI 450 000

Black knobs 400 series for VI 492

Electronic control

Set of 5 knobs

Installation accessories

VA 420 004

Connection strip for combination with other Vario appliances of the 400 series for flush mounting

VA 420 010

Connection strip for combination with other Vario appliances of the 400 series for surface mounting

Special accessories

CA 051 301

Teppan Yaki plate made of multi ply material

For flex induction cooktop.

CA 052 300

Griddle plate in cast aluminum

Non-stick.

For flex induction cooktop.

CA 050 300

Flex Pan set, 3 pcs.

Non-stick coating.

For flex induction cooktop.

CA 055 300

Flex Pan large

Non-stick coating.

For flex induction cooktop.

WP 400 001

Wok pan made of multiple-layer material

With round bottom and handle, ø 36 cm, 6 litres, height 10 cm.

WZ 400 000

Wok attachment for wok pan

Only for Vario induction cooktops.

Vario flex induction cooktop 400 series VI 492

- Flex function for combining the rectangular cooking areas
- Free positioning of cookware inside combined cooking areas
- Large cooking zone for pots up to ø 32 cm
- Ideal for the original wok pan with round bottom, with wok ring
- Solid stainless steel knob, also selectable with black robust finishing, for precise control and personalisation
- Precision crafted 3 mm stainless steel
- For surface mounting with a visible edge or for flush mounting
- Can be combined perfectly with other Vario appliances of the 400 series

Cooking zones

2 flex induction cooking areas

23x19 cm (2200 W, with booster 3700 W), linked together 23x38 cm (3300 W, with booster 3700 W).

2 flex induction cooking areas

23x19 cm (2200 W, with booster 3700 W), linked together 23x38 cm (3300 W, with booster 3700 W).

1 induction cooking zone ø 21 cm

(2200 W, with booster 3700 W), automatically switches to ø 26 cm (2600 W, with booster 3700 W) and to ø 32 cm (3300 W, with booster 3700 W).

Handling

Control knobs with illuminated ring, cooking zone and output level markings. Electronic power control in 12 output levels.

User friendly control with bicoloured display (white / orange).

Features

Flex function for rectangular cooking areas.

Frying sensor function.

Booster function.

Stopwatch.

Short-term timer.

Options menu.

Power management.

Selected digital services (Home Connect)

Cooktop-based ventilation control (with suitable hood).

Remote monitoring.

Remote diagnostics.

Please read additional information on Home Connect on page 411.

Safety

Operation indicator.

Pot detection.

2-stage residual heat indication.

Safety shut-off.

Planning notes

Depending on the type of installation (surface-mounted or flush-mounted), the specific location of the cut-out and the knob positions may vary.

The horizontal positioning of the knobs may be aligned with the specific cooking areas and zones.

The drawing "Installation of the control knob" must be observed if the panel is more than 23 mm thick (there must be a recess at the rear).

If combining several Vario appliances of the 400 series, select combinations with or without appliance cover, and a connection strip VA 420 must be placed between the appliances.

Depending on the type of installation, the corresponding connection strip must be provided.

The bearing capacity and stability, in the case of thinner worktops in particular, must be supported using suitable substructures. Take into account the appliance weight and additional loads.

Additional instructions for flush mounting: Installation is possible in worktops made of stone, synthetics or solid wood. Heat resistance and watertight sealing of the cut edges must be observed.

Concerning other materials please consult the worktop manufacturer.

The groove must be continuous and even, so that uniform placing of the appliance on the gasket is ensured.

Do not use discontinuous lining.

The joint width may vary due to size tolerances of the combinations and of the worktop cut-out.

Please read additional planning notes on page 130 and 132.

If installing several appliances in individual cut-outs allow for a division bar of minimum 50 mm between the individual cut-outs.

Operates with magnetic (induction) iron pots and pans only. For an optimal heat distribution, the use of sandwich bottom cookware is recommended.

Special accessories

(please order as spare parts):

Part No. 17006018

Frying sensor pan, ø 20 cm

Part No. 17006184

Frying sensor pan, ø 24 cm

Part No. 17006185

Frying sensor pan, ø 28 cm

Part No. 17006019

Frying sensor pan, ø 32 cm

Appliance can be snapped into the worktop from above.

Appliance weight: approx. 24 kg.

Please read the installation details regarding air ducting on page 210.

Connection

Total connected load 11.1 kW.

Connecting cable 1.5 m without plug.

Connecting cables 0.3 m and 1 m for control knobs.

Power consumption standby/display off 0.5 W.

Power consumption standby/network 1.9 W.

Please check the user manual for how to switch off the WiFi module.

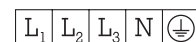

Installation of the cooktop; surface mounting

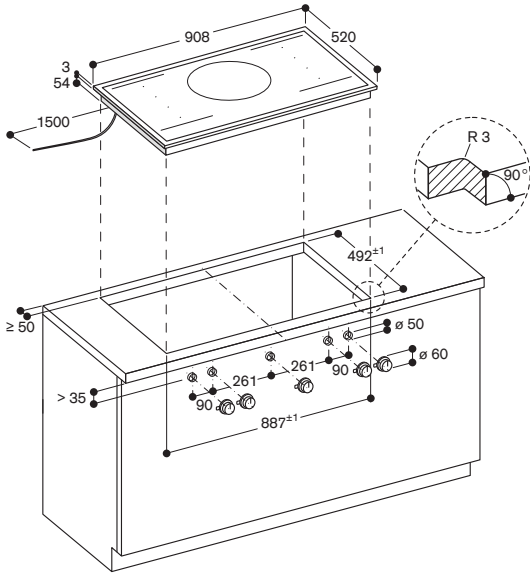

measurements in mm

Installation of the control knob

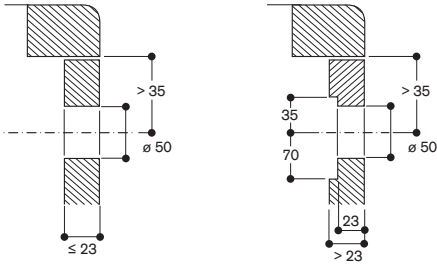

measurements in mm

Installation of the cooktop; flush mounting

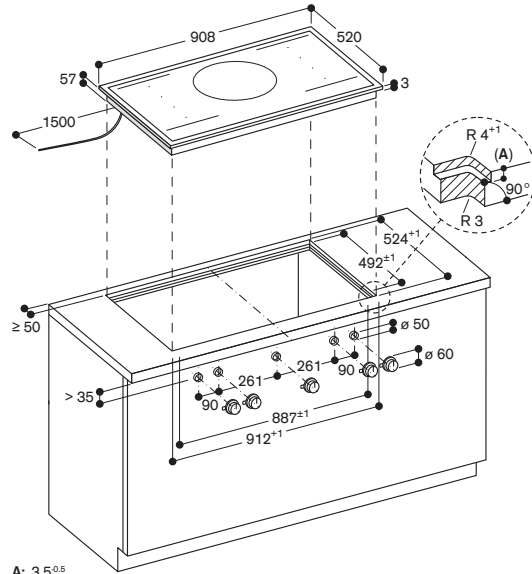

A: 3.5^{±0.5}
measurements in mm

Installation of the control knob

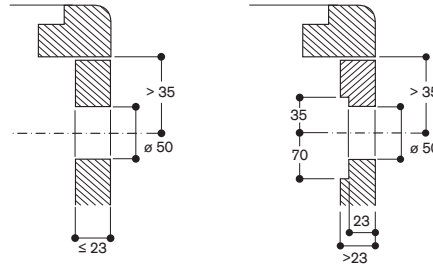

measurements in mm

View from above

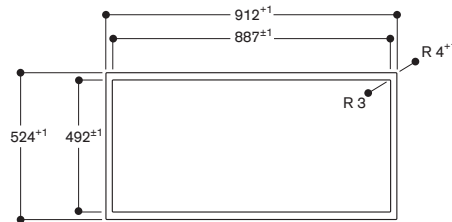

measurements in mm

Longitudinal section

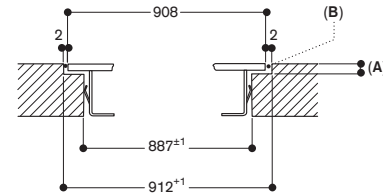

A: 3.5^{±0.5}
B: Fill with silicone

measurements in mm

Cross-section

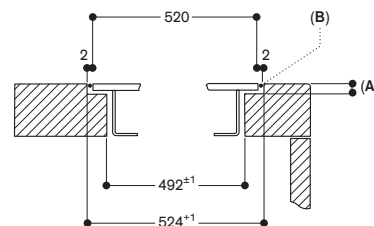

A: 3.5^{±0.5}
B: Fill with silicone

measurements in mm



VI 482 105

Frameless

Width 80 cm

Knobs need to be ordered separately

Necessary installation accessories

CKI 440 010

Stainless steel knobs 400 series for

VI 462, VI 482, CV 482, CV 492

Electronic control

Set of 4 knobs

CKI 440 000

Black knobs 400 series for VI 462,

VI 482, CV 482, CV 492

Electronic control

Set of 4 knobs

Installation accessories

VA 420 004

Connection strip for combination with other Vario appliances of the 400 series for flush mounting

Special accessories

CA 051 301

Teppan Yaki plate made of multi ply material

For flex induction cooktop.

CA 052 300

Griddle plate in cast aluminum

Non-stick.

For flex induction cooktop.

CA 050 300

Flex Pan set, 3 pcs.

Non-stick coating.

For flex induction cooktop.

CA 055 300

Flex Pan large

Non-stick coating.

For flex induction cooktop.

Vario flex induction cooktop 400 series

VI 482

- Flex function for combining the rectangular cooking areas
- Free positioning of cookware inside combined cooking areas with automatic extension up to 30 cm width
- Solid stainless steel knob, also selectable with black robust finishing, for precise control and personalisation
- Frameless for flush mounting
- Can be combined perfectly with other Vario appliances of the 400 series

Cooking zones

2 flex induction cooking areas 23x20 cm (2200 W, with booster 3700 W), linked together 23x40 cm (3300 W, with booster 3700 W), with automatic extension up to 32x30 cm (3300 W, with booster 3700 W).

2 flex induction cooking areas 23x20 cm (2200 W, with booster 3700 W), linked together 23x40 cm (3300 W, with booster 3700 W), with automatic extension up to 32x30 cm (3300 W, with booster 3700 W).

Handling

Control knobs with illuminated ring, cooking zone and output level markings. Electronic power control in 12 output levels.

User friendly control with bicoloured display (white / orange).

Features

Flex function for rectangular cooking areas.

Frying sensor function.

Booster function.

Stopwatch.

Short-term timer.

Options menu.

Power management.

Selected digital services (Home Connect)

Cooktop-based ventilation control (with suitable hood).

Remote monitoring.

Remote diagnostics.

Please read additional information on Home Connect on page 411.

Safety

Operation indicator.

Pot detection.

2-stage residual heat indication.

Safety shut-off.

Planning notes

The horizontal positioning of the knobs may be aligned with the specific cooking areas.

The drawing "Installation of the control knob" must be observed if the panel is more than 23 mm thick (there must be a recess at the rear).

The bearing capacity and stability, in the case of thinner worktops in particular, must be supported using suitable substructures. Take into account the appliance weight and additional loads. Installation is possible in worktops made of stone, synthetics or solid wood. Heat resistance and watertight

sealing of the cut edges must be observed. Concerning other materials please consult the worktop manufacturer. The groove must be continuous and even, so that uniform placing of the appliance on the gasket is ensured. Do not use discontinuous lining. The joint width may vary due to size tolerances of the combinations and of the worktop cut-out.

Please read additional planning notes on page 130 – 133.

If installing several appliances in individual cut-outs allow for a division bar of minimum 50 mm between the individual cut-outs. Operates with magnetic (induction) iron pots and pans only. For an optimal heat distribution, the use of sandwich bottom cookware is recommended.

Special accessories

(please order as spare parts):

Part No. 17006018

Frying sensor pan, ø 20 cm

Part No. 17006184

Frying sensor pan, ø 24 cm

Part No. 17006185

Frying sensor pan, ø 28 cm

The wok pan WP 400 001 cannot be used with this appliance.

Appliance can be snapped into the worktop from above.

Appliance weight: approx. 18 kg.

Please read the installation details regarding air ducting on page 210.

Connection

Total connected load 7.4 kW.

Connecting cable 1.5 m without plug.

Connecting cables 0.3m and 1 m for control knobs.

Power consumption standby/display off 0.5 W.

Power consumption standby/network 1.7 W.

Please check the user manual for how to switch off the WiFi module.

Length of connection cable, water in- and outlet see detailed drawing on page 103.

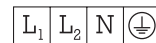

Installation of the cooktop; flush mounting

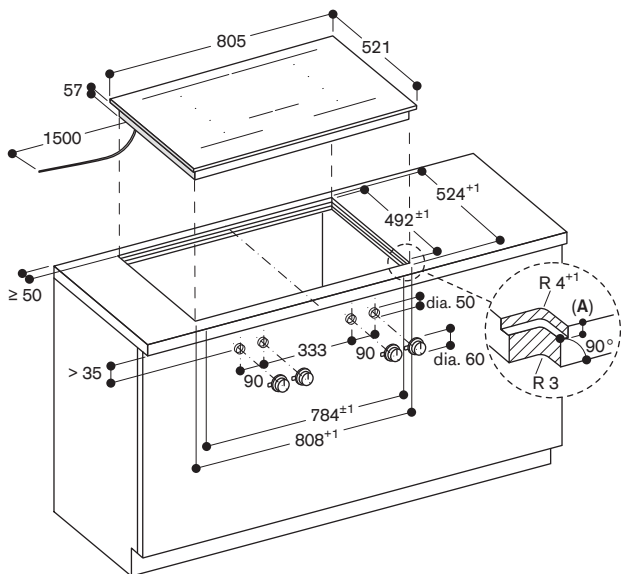

A: $6.5^{+0.5}$
measurements in mm

Installation of the control knob

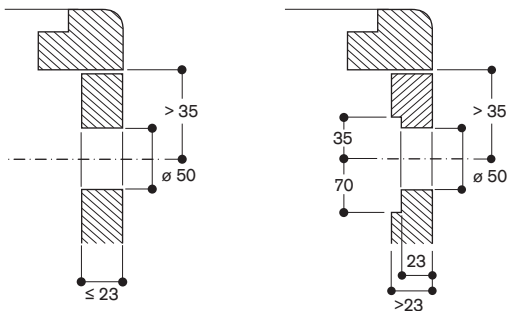

measurements in mm

View from above

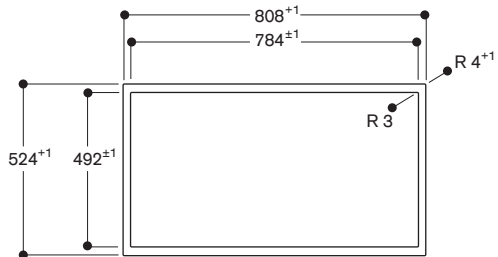

measurements in mm

Longitudinal section

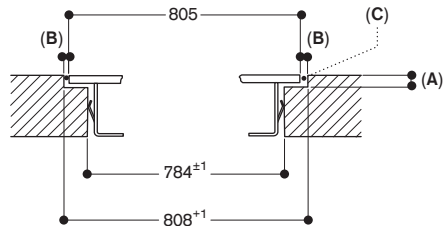

A: $6.5^{+0.5}$
B: 1.5
C: Fill with silicone
measurements in mm

Cross-section

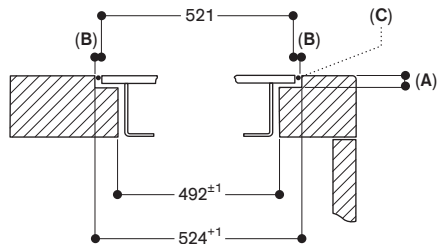

A: $6.5^{+0.5}$
B: 1.5
C: Fill with silicone
measurements in mm



VI 482 115

Stainless steel frame

Width 80 cm

Knobs need to be ordered separately

Necessary installation accessories

CKI 440 010

Stainless steel knobs 400 series for

VI 462, VI 482, CV 482, CV 492

Electronic control

Set of 4 knobs

CKI 440 000

Black knobs 400 series for VI 462,

VI 482, CV 482, CV 492

Electronic control

Set of 4 knobs

Installation accessories

VA 420 004

Connection strip for combination with other Vario appliances of the 400 series for flush mounting

VA 420 010

Connection strip for combination with other Vario appliances of the 400 series for surface mounting

Special accessories

CA 051 301

Teppan Yaki plate made of multi ply material

For flex induction cooktop.

CA 052 300

Griddle plate in cast aluminum

Non-stick.

For flex induction cooktop.

CA 050 300

Flex Pan set, 3 pcs.

Non-stick coating.

For flex induction cooktop.

CA 055 300

Flex Pan large

Non-stick coating.

For flex induction cooktop.

Vario flex induction cooktop 400 series

VI 482

- Flex function for combining the rectangular cooking areas
- Free positioning of cookware inside combined cooking areas with automatic extension up to 32 cm width
- Solid stainless steel knob, also selectable with black robust finishing, for precise control and personalisation
- Precision crafted 3 mm stainless steel
- For surface mounting with a visible edge or for flush mounting
- Can be combined perfectly with other Vario appliances of the 400 series

Cooking zones

2 flex induction cooking areas

23x19 cm (2200 W, with booster 3700 W), linked together 23x38 cm (3300 W, with booster 3700 W), with automatic extension up to 32x30 cm (3300 W, with booster 3700 W).

2 flex induction cooking areas

23x19 cm (2200 W, with booster 3700 W), linked together 23x38 cm (3300 W, with booster 3700 W), with automatic extension up to 32x30 cm (3300 W, with booster 3700 W).

Handling

Control knobs with illuminated ring, cooking zone and output level markings. Electronic power control in 12 output levels.

User friendly control with bicoloured display (white / orange).

Features

Flex function for rectangular cooking areas.

Frying sensor function.

Booster function.

Stopwatch.

Short-term timer.

Options menu.

Power management.

Selected digital services (Home Connect)

Cooktop-based ventilation control (with suitable hood).

Remote monitoring.

Remote diagnostics.

Please read additional information on Home Connect on page 411.

Safety

Operation indicator.

Pot detection.

2-stage residual heat indication.

Safety shut-off.

Planning notes

Depending on the type of installation (surface-mounted or flush-mounted), the specific location of the cut-out and the knob positions may vary. The horizontal positioning of the knobs may be aligned with the specific cooking areas.

The drawing "Installation of the control knob" must be observed if the panel is more than 23 mm thick (there must be a recess at the rear).

If combining several Vario appliances of the 400 series, select combinations with or without appliance cover, and a connection strip VA 420 must be placed between the appliances.

Depending on the type of installation, the corresponding connection strip must be provided.

The bearing capacity and stability, in the case of thinner worktops in particular, must be supported using suitable substructures. Take into account the appliance weight and additional loads. Additional instructions for flush mounting: Installation is possible in worktops made of stone, synthetics or solid wood. Heat resistance and watertight sealing of the cut edges must be observed. Concerning other materials please consult the worktop manufacturer. The groove must be continuous and even, so that uniform placing of the appliance on the gasket is ensured. Do not use discontinuous lining. The joint width may vary due to size tolerances of the combinations and of the worktop cut-out.

Please read additional planning notes on page 130 – 133.

If installing several appliances in individual cut-outs allow for a division bar of minimum 50 mm between the individual cut-outs.

Operates with magnetic (induction) iron pots and pans only. For an optimal heat distribution, the use of sandwich bottom cookware is recommended.

Special accessories

(please order as spare parts):

Part No. 17006018

Frying sensor pan, ø 20 cm

Part No. 17006184

Frying sensor pan, ø 24 cm

Part No. 17006185

Frying sensor pan, ø 28 cm

The wok pan WP 400001 cannot be used with this appliance.

Appliance can be snapped into the worktop from above.

Appliance weight: approx. 20 kg.

Please read the installation details regarding air ducting on page 210.

Connection

Total connected load 7.4 kW.

Connecting cable 1.5 m without plug.

Connecting cables 0.3 m and 1 m for control knobs.

Power consumption standby/display off 0.5 W.

Power consumption standby/network 1.7 W.

Please check the user manual for how to switch off the WiFi module.

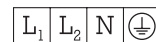

Installation of the cooktop; surface mounting

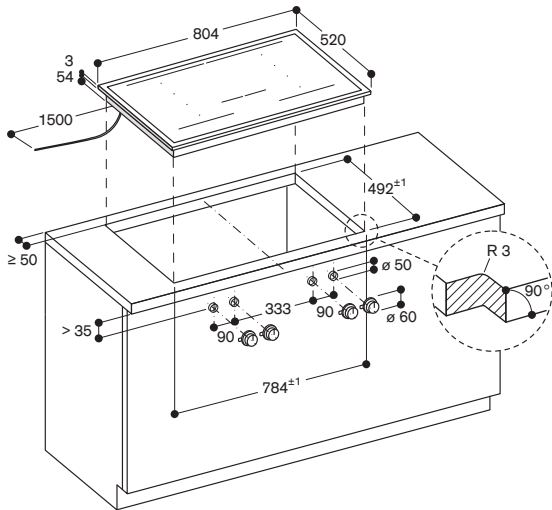

measurements in mm

Installation of the control knob

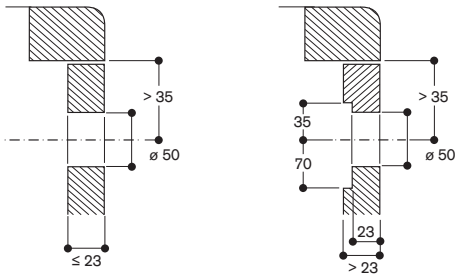

measurements in mm

Installation of the cooktop; flush mounting

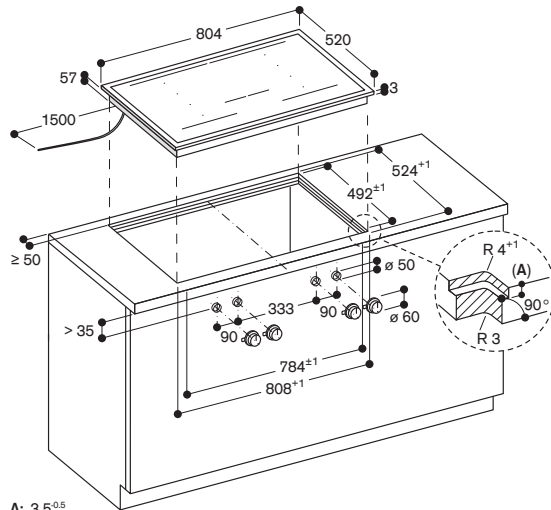

A: 3.5^{±0.5}
measurements in mm

Installation of the control knob

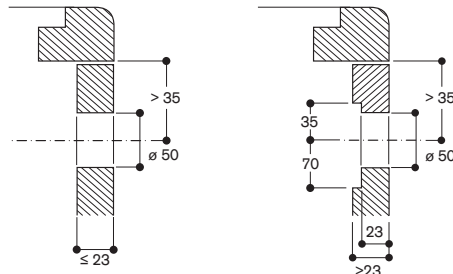

measurements in mm

View from above

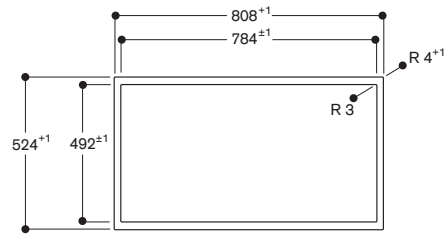

measurements in mm

Longitudinal section

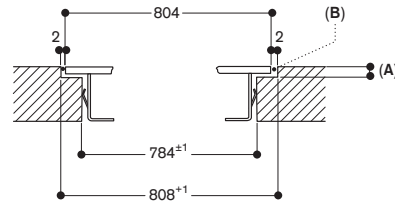

A: 3.5^{±0.5}
B: Fill with silicone
measurements in mm

Cross-section

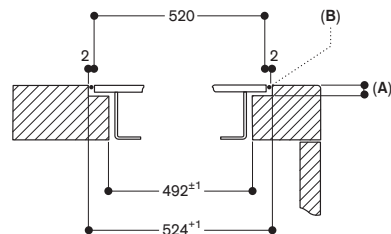

A: 3.5^{±0.5}
B: Fill with silicone
measurements in mm



VI 462 105

Frameless
Width 60 cm
Knobs need to be ordered separately

Necessary installation accessories

CKI 440 010

Stainless steel knobs 400 series for VI 462, VI 482, CV 482, CV 492

Electronic control
Set of 4 knobs

CKI 440 000

Black knobs 400 series for VI 462, VI 482, CV 482, CV 492

Electronic control
Set of 4 knobs

Installation accessories

VA 420 004

Connection strip for combination with other Vario appliances of the 400 series for flush mounting

Special accessories

CA 051 301

Teppan Yaki plate made of multi ply material
For flex induction cooktop.

CA 052 300

Griddle plate in cast aluminum
Non-stick.
For flex induction cooktop.

CA 050 300

Flex Pan set, 3 pcs.
Non-stick coating.
For flex induction cooktop.

CA 055 300

Flex Pan large
Non-stick coating.
For flex induction cooktop.

Vario flex induction cooktop 400 series

VI 462

- Flex function for combining the rectangular cooking areas
- Free positioning of cookware inside combined cooking areas with automatic extension up to 30 cm width
- Solid stainless steel knob, also selectable with black robust finishing, for precise control and personalisation
- Frameless for flush mounting
- Can be combined perfectly with other Vario appliances of the 400 series

Cooking zones

2 flex induction cooking areas 23x20 cm (2200 W, with booster 3700 W), linked together 23x40 cm (3300 W, with booster 3700 W), with automatic extension up to 30x30 cm (3300 W, with booster 3700 W).

2 flex induction cooking areas 23x20 cm (2200 W, with booster 3700 W), linked together 23x40 cm (3300 W, with booster 3700 W).

Handling

Control knobs with illuminated ring, cooking zone and output level markings. Electronic power control in 12 output levels.

User friendly control with bicoloured display (white / orange).

Features

Flex function for rectangular cooking areas.
Frying sensor function.
Booster function.
Stopwatch.
Short-term timer.
Options menu.
Power management.

Selected digital services (Home Connect)

Cooktop-based ventilation control (with suitable hood).
Remote monitoring.
Remote diagnostics.

Please read additional information on Home Connect on page 411.

Safety

Operation indicator.
Pot detection.
2-stage residual heat indication.
Safety shut-off.

Planning notes

The horizontal positioning of the knobs may be aligned with the specific cooking areas.

The drawing "Installation of the control knob" must be observed if the panel is more than 23 mm thick (there must be a recess at the rear).

The bearing capacity and stability, in the case of thinner worktops in particular, must be supported using suitable substructures. Take into account the appliance weight and additional loads. Installation is possible in worktops made of stone, synthetics or solid wood. Heat resistance and watertight sealing of the cut edges must be observed. Concerning other materials please consult the worktop manufacturer.

The groove must be continuous and even, so that uniform placing of the appliance on the gasket is ensured. Do not use discontinuous lining. The joint width may vary due to size tolerances of the combinations and of the worktop cut-out.

Please read additional planning notes on page 130 – 133.

If installing several appliances in individual cut-outs allow for a division bar of minimum 50 mm between the individual cut-outs. Operates with magnetic (induction) iron pots and pans only. For an optimal heat distribution, the use of sandwich bottom cookware is recommended.

Special accessories

(please order as spare parts):
Part No. 17006018
Frying sensor pan, ø 20 cm
Part No. 17006184
Frying sensor pan, ø 24 cm
Part No. 17006185
Frying sensor pan, ø 28 cm

The wok pan WP 400001 cannot be used with this appliance. Appliance can be snapped into the worktop from above. Appliance weight: approx. 17 kg.

Please read the installation details regarding air ducting on page 210.

Connection

Total connected load 7.4 kW.
Connecting cable 1.5 m without plug.
Connecting cables 0.3 m and 1 m for control knobs.
Power consumption standby/display off 0.5 W.
Power consumption standby/network 1.7 W.
Please check the user manual for how to switch off the WiFi module. Length of connection cable, water in- and outlet see detailed drawing on page 107.

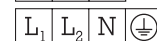

Installation of the cooktop; flush mounting

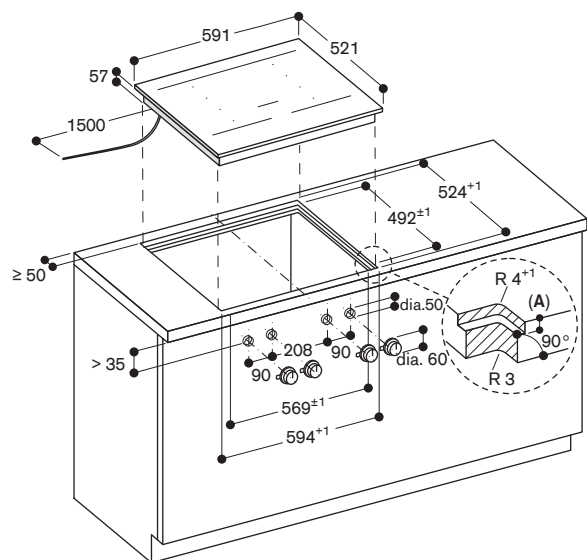

A: 6.5^{+0.5}
 measurements in mm

Installation of the control knob

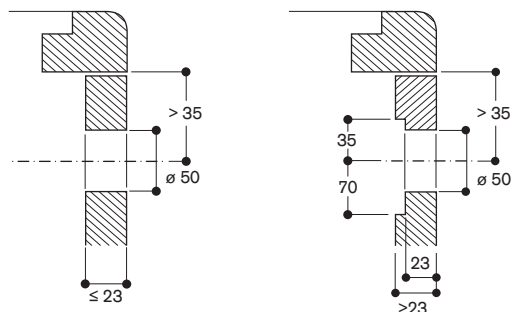

measurements in mm

View from above

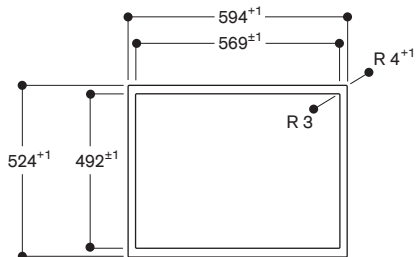

measurements in mm

Longitudinal section

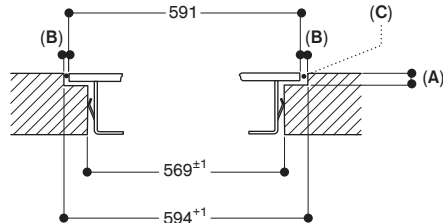

A: 6.5^{+0.5}
 B: 1.5
 C: Fill with silicone
 measurements in mm

Cross-section

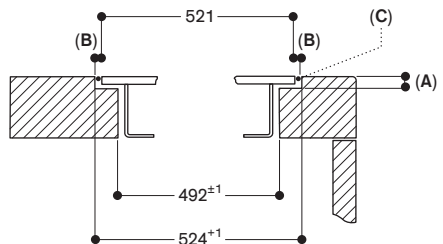

A: 6.5^{+0.5}
 B: 1.5
 C: Fill with silicone
 measurements in mm



VI 462 115

Stainless steel frame
Width 60 cm
Knobs need to be ordered separately

Necessary installation accessories

CKI 440 010

Stainless steel knobs 400 series for VI 462, VI 482, CV 482, CV 492
Electronic control
Set of 4 knobs

CKI 440 000

Black knobs 400 series for VI 462, VI 482, CV 482, CV 492
Electronic control
Set of 4 knobs

Installation accessories

VA 420 004

Connection strip for combination with other Vario appliances of the 400 series for flush mounting

VA 420 010

Connection strip for combination with other Vario appliances of the 400 series for surface mounting

Special accessories

CA 051 301

Teppan Yaki plate made of multi ply material
For flex induction cooktop.

CA 052 300

Griddle plate in cast aluminum
Non-stick.
For flex induction cooktop.

CA 050 300

Flex Pan set, 3 pcs.
Non-stick coating.
For flex induction cooktop.

CA 055 300

Flex Pan large
Non-stick coating.
For flex induction cooktop.

Vario flex induction cooktop 400 series

VI 462

- Flex function for combining the rectangular cooking areas
- Free positioning of cookware inside combined cooking areas with automatic extension up to 30 cm width
- Solid stainless steel knob, also selectable with black robust finishing, for precise control and personalisation
- Precision crafted 3 mm stainless steel
- For surface mounting with a visible edge or for flush mounting
- Can be combined perfectly with other Vario appliances of the 400 series

Cooking zones

2 flex induction cooking areas 23x19 cm (2200 W, with booster 3700 W), linked together 23x38 cm (3300 W, with booster 3700 W), with automatic extension up to 30x30 cm (3300 W, with booster 3700 W).

2 flex induction cooking areas 23x19 cm (2200 W, with booster 3700 W), linked together 23x38 cm (3300 W, with booster 3700 W).

Handling

Control knobs with illuminated ring, cooking zone and output level markings. Electronic power control in 12 output levels. User friendly control with bicoloured display (white / orange).

Features

Flex function for rectangular cooking areas.
Frying sensor function.
Booster function.
Stopwatch.
Short-term timer.
Options menu.
Power management.

Selected digital services

(Home Connect)
Cooktop-based ventilation control (with suitable hood).
Remote monitoring.
Remote diagnostics.

Please read additional information on Home Connect on page 411.

Safety

Operation indicator.
Pot detection.
2-stage residual heat indication.
Safety shut-off.

Planning notes

Depending on the type of installation (surface-mounted or flush-mounted), the specific location of the cut-out and the knob positions may vary. The horizontal positioning of the knobs may be aligned with the specific cooking areas. The drawing "Installation of the control knob" must be observed if the panel is more than 23 mm thick (there must be a recess at the rear).

If combining several Vario appliances of the 400 series, select combinations with or without appliance cover, and a connection strip VA 420 must be placed between the appliances. Depending on the type of installation, the corresponding connection strip must be provided. The bearing capacity and stability, in the case of thinner worktops in particular, must be supported using suitable substructures. Take into account the appliance weight and additional loads. Additional instructions for flush mounting: Installation is possible in worktops made of stone, synthetics or solid wood. Heat resistance and watertight sealing of the cut edges must be observed. Concerning other materials please consult the worktop manufacturer. The groove must be continuous and even, so that uniform placing of the appliance on the gasket is ensured. Do not use discontinuous lining. The joint width may vary due to size tolerances of the combinations and of the worktop cut-out.

Please read additional planning notes on page 130 – 133.

If installing several appliances in individual cut-outs allow for a division bar of minimum 50 mm between the individual cut-outs. Operates with magnetic (induction) iron pots and pans only. For an optimal heat distribution, the use of sandwich bottom cookware is recommended.

Special accessories

(please order as spare parts):
Part No. 17006018
Frying sensor pan, ø 20 cm
Part No. 17006184
Frying sensor pan, ø 24 cm
Part No. 17006185
Frying sensor pan, ø 28 cm

The wok pan WP 400001 cannot be used with this appliance. Appliance can be snapped into the worktop from above. Appliance weight: approx. 17 kg.

Please read the installation details regarding air ducting on page 210.

Connection

Total connected load 7.4 kW.
Connecting cable 1.5 m without plug.
Connecting cables 0.3 m and 1 m for control knobs.
Power consumption standby/display off 0.5 W.
Power consumption standby/network 1.7 W.
Please check the user manual for how to switch off the WiFi module.

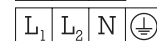

Installation of the cooktop; surface mounting

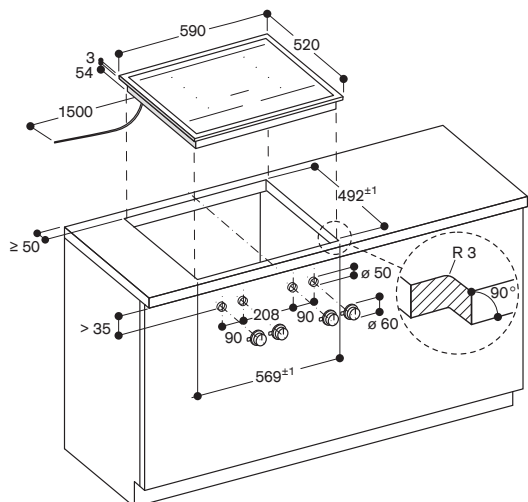

measurements in mm

Installation of the control knob

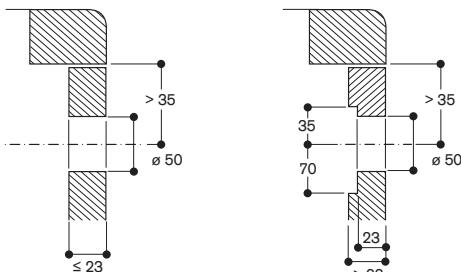

measurements in mm

Installation of the cooktop; flush mounting

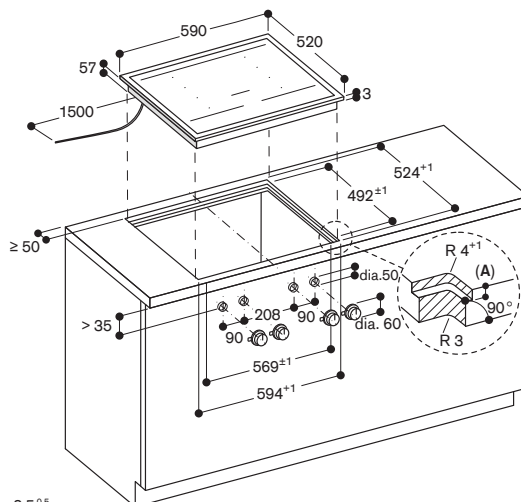

A: 3.5^{0.5}

measurements in mm

Installation of the control knob

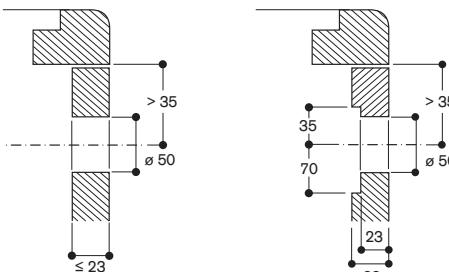

measurements in mm

View from above

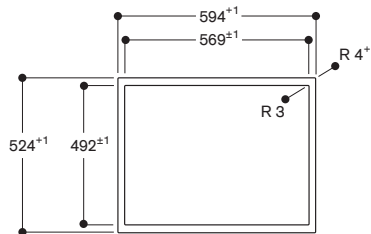

measurements in mm

Longitudinal section

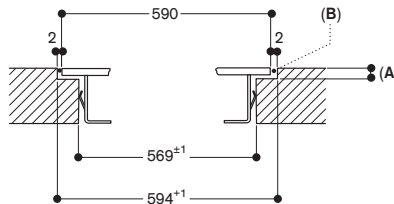

A: 3.5^{0.5}

B: Fill with silicone

measurements in mm

Cross-section

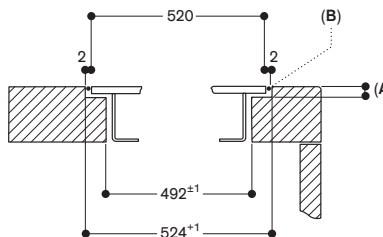

A: 3.5^{0.5}

B: Fill with silicone

measurements in mm



VI 422 105

Frameless
Width 38 cm
Knobs need to be ordered separately

Necessary installation accessories

CKI 420 010

Stainless steel knobs 400 series for VI 422

Electronic control
Set of 2 knobs

CKI 420 000

Black knobs 400 series for VI 422
Electronic control
Set of 2 knobs

Installation accessories

VA 420 004

Connection strip for combination with other Vario appliances of the 400 series for flush mounting

Special accessories

CA 051 301

Teppan Yaki plate made of multi ply material
For flex induction cooktop.

CA 052 300

Griddle plate in cast aluminum
Non-stick.

For flex induction cooktop.

CA 050 300

Flex Pan set, 3 pcs.

Non-stick coating.

For flex induction cooktop.

CA 055 300

Flex Pan large

Non-stick coating.

For flex induction cooktop.

Vario flex induction cooktop 400 series

VI 422

- Flex function for combining the rectangular cooking areas
- Free positioning of cookware inside combined cooking areas
- Solid stainless steel knob, also selectable with black robust finishing, for precise control and personalisation
- Frameless for flush mounting
- Can be combined perfectly with other Vario appliances of the 400 series

Cooking zones

2 flex induction cooking areas 24x20 cm (2200 W, with booster 3700 W), linked together 24x40 cm (3300 W, with booster 3700 W).

Handling

Control knobs with illuminated ring, cooking zone and output level markings. Electronic power control in 12 output levels.

User friendly control with bicoloured display (white / orange).

Features

Flex function for rectangular cooking areas.

Frying sensor function.

Booster function.

Stopwatch.

Short-term timer.

Options menu.

Power management.

Selected digital services

(Home Connect)

Cooktop-based ventilation control

(with suitable hood).

Remote monitoring.

Remote diagnostics.

Please read additional information on Home Connect on page 411.

Safety

Operation indicator.

Pot detection.

2-stage residual heat indication.

Safety shut-off.

Planning notes

The horizontal positioning of the knobs may be aligned with the specific cooking areas.

The drawing "Installation of the control knob" must be observed if the panel is more than 23 mm thick (there must be a recess at the rear).

The bearing capacity and stability, in the case of thinner worktops in particular, must be supported using suitable substructures. Take into account the appliance weight and additional loads. Installation is possible in worktops made of stone, synthetics or solid wood. Heat resistance and watertight sealing of the cut edges must be observed. Concerning other materials please consult the worktop manufacturer. The groove must be continuous and even, so that uniform placing of the appliance on the gasket is ensured. Do not use discontinuous lining.

The joint width may vary due to size tolerances of the combinations and of the worktop cut-out.

If installing several appliances in individual cut-outs allow for a division bar of minimum 50 mm between the individual cut-outs.

Operates with magnetic (induction) iron pots and pans only. For an optimal heat distribution, the use of sandwich bottom cookware is recommended.

Special accessories

(please order as spare parts):

Part No. 17006018

Frying sensor pan, ø 20 cm

Part No. 17006184

Frying sensor pan, ø 24 cm

Appliance can be snapped into the worktop from above.

Appliance weight: approx. 9 kg.

Please read the installation details regarding air ducting on page 210.

Please read additional planning notes on page 130 – 133.

Connection

Total connected load 3.7 kW.

Connecting cable 1.5 m without plug.

Connecting cables 0.3 m and 1 m for control knobs.

Power consumption standby/display off 0.5 W.

Power consumption standby/network 1.4 W.

Please check the user manual for how to switch off the WiFi module.

Length of connection cable, water in- and outlet see detailed drawing on page 111.



Installation of the cooktop; flush mounting

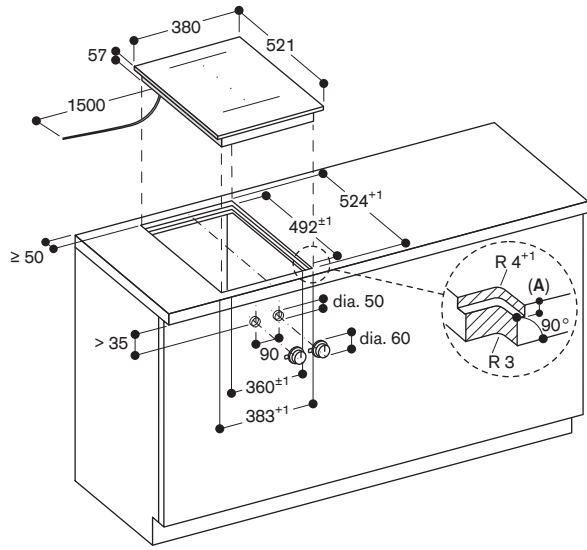

A: $6.5^{+0.5}$
measurements in mm

View from above

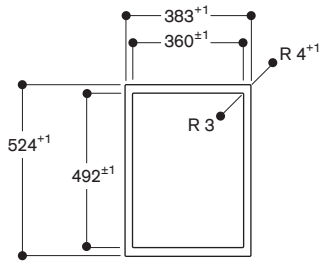

measurements in mm

Installation of the control knob

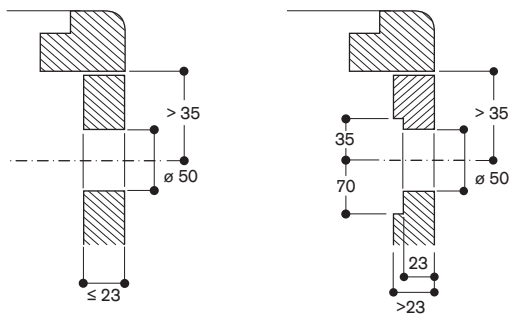

measurements in mm

Longitudinal section

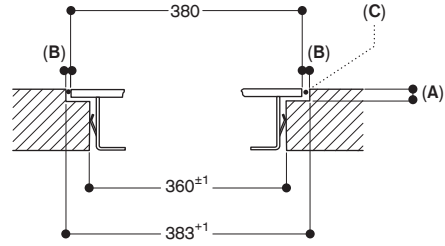

A: $6.5^{+0.5}$
B: 1.5
C: Fill with silicone

measurements in mm

Cross-section

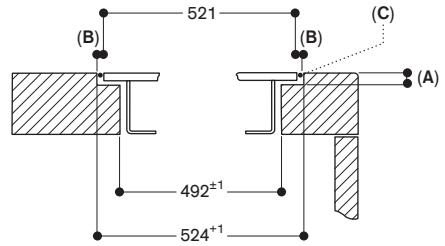

A: $6.5^{+0.5}$
B: 1.5
C: Fill with silicone

measurements in mm



VI 422 115

Stainless steel frame
Width 38 cm
Knobs need to be ordered separately

Necessary installation accessories

CKI 420 010

Stainless steel knobs 400 series for VI 422

Electronic control
Set of 2 knobs

CKI 420 000

Black knobs 400 series for VI 422

Electronic control
Set of 2 knobs

Installation accessories

VA 420 004

Connection strip for combination with other Vario appliances of the 400 series for flush mounting

VA 420 010

Connection strip for combination with other Vario appliances of the 400 series for surface mounting

Special accessories

CA 051 301

Teppan Yaki plate made of multi ply material
For flex induction cooktop.

CA 052 300

Griddle plate in cast aluminum
Non-stick.

For flex induction cooktop.

CA 050 300

Flex Pan set, 3 pcs.

Non-stick coating.

For flex induction cooktop.

CA 055 300

Flex Pan large

Non-stick coating.

For flex induction cooktop.

Vario flex induction cooktop 400 series

VI 422

- Flex function for combining the rectangular cooking areas
- Free positioning of cookware inside combined cooking areas
- Solid stainless steel knob, also selectable with black robust finishing, for precise control and personalisation
- Precision crafted 3 mm stainless steel
- For surface mounting with a visible edge or for flush mounting
- Can be combined perfectly with other Vario appliances of the 400 series

Cooking zones

2 flex induction cooking areas 24x19 cm (2200 W, with booster 3700 W), linked together 24x38 cm (3300 W, with booster 3700 W).

Handling

Control knobs with illuminated ring, cooking zone and output level markings. Electronic power control in 12 output levels.

User friendly control with bicoloured display (white / orange).

Features

Flex function for rectangular cooking areas.

Frying sensor function.

Booster function.

Stopwatch.

Short-term timer.

Options menu.

Power management.

Selected digital services

(Home Connect)

Cooktop-based ventilation control (with suitable hood).

Remote monitoring.

Remote diagnostics.

Please read additional information on Home Connect on page 411.

Safety

Operation indicator.

Pot detection.

2-stage residual heat indication.

Safety shut-off.

Planning notes

Depending on the type of installation (surface-mounted or flush-mounted), the specific location of the cut-out and the knob positions may vary.

The horizontal positioning of the knobs may be aligned with the specific cooking areas.

The drawing "Installation of the control knob" must be observed if the panel is more than 23 mm thick (there must be a recess at the rear).

If combining several Vario appliances of the 400 series, select combinations with or without appliance cover, and a connection strip VA 420 must be placed between the appliances.

Depending on the type of installation, the corresponding connection strip must be provided.

The bearing capacity and stability, in the case of thinner worktops in particular, must be supported using suitable substructures. Take into account the appliance weight and additional loads. Additional instructions for flush mounting: Installation is possible in worktops made of stone, synthetics or solid wood. Heat resistance and watertight sealing of the cut edges must be observed. Concerning other materials please consult the worktop manufacturer. The groove must be continuous and even, so that uniform placing of the appliance on the gasket is ensured. Do not use discontinuous lining. The joint width may vary due to size tolerances of the combinations and of the worktop cut-out.

Please read additional planning notes on page 130 – 133.

If installing several appliances in individual cut-outs allow for a division bar of minimum 50 mm between the individual cut-outs.

Operates with magnetic (induction) iron pots and pans only. For an optimal heat distribution, the use of sandwich bottom cookware is recommended.

Special accessories

(please order as spare parts):

Part No. 17006018

Frying sensor pan, ø 20 cm

Part No. 17006184

Frying sensor pan, ø 24 cm

Appliance can be snapped into the worktop from above.

Appliance weight: approx. 10 kg.

Please read the installation details regarding air ducting on page 210.

Connection

Total connected load 3.7 kW.

Connecting cable 1.5 m without plug.

Connecting cables 0.3m and 1 m for control knobs.

Power consumption standby/display off 0.5 W.

Power consumption standby/network 1.4 W.

Please check the user manual for how to switch off the WiFi module.



Installation of the cooktop; surface mounting

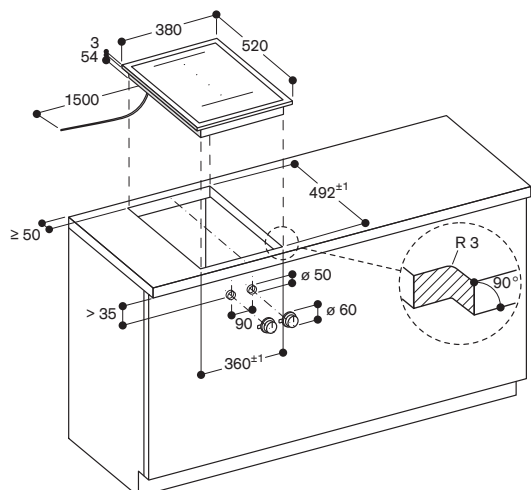

measurements in mm

Installation of the control knob

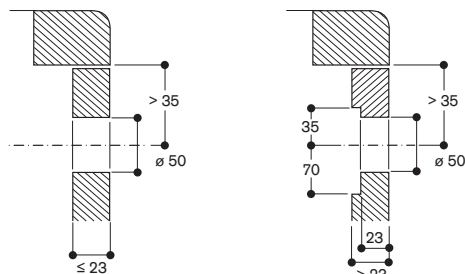

measurements in mm

Installation of the cooktop; flush mounting

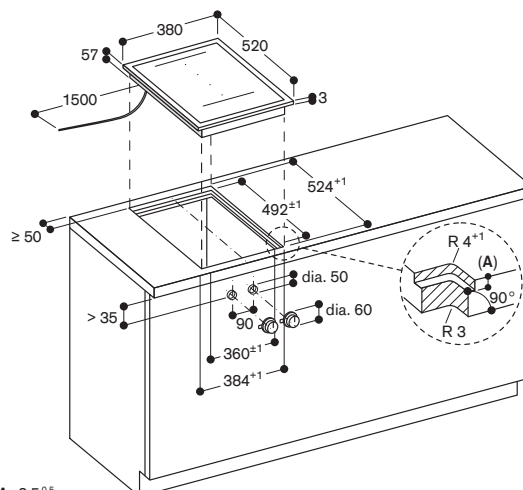

A: 3.5^{0.5}
measurements in mm

Installation of the control knob

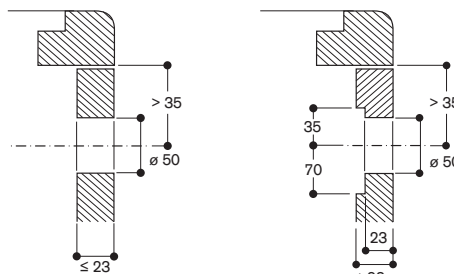

measurements in mm

View from above

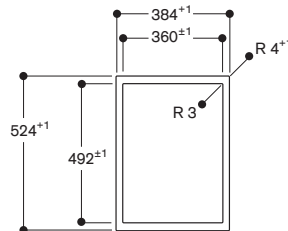

measurements in mm

Longitudinal section

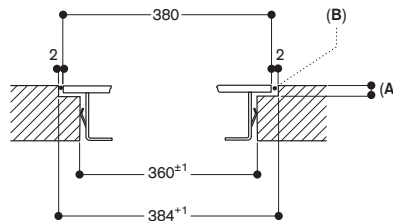

A: 3.5^{0.5}
B: Fill with silicone

measurements in mm

Cross-section

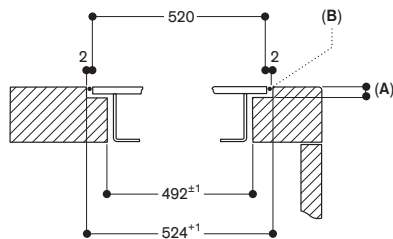

A: 3.5^{0.5}
B: Fill with silicone

measurements in mm



VI 414 105

Frameless

Width 38 cm

Knob needs to be ordered separately

Necessary installation accessories

CKI 410 010

Stainless steel knob 400 series for VI 414

Electronic control

Set of 1 knob

CKI 410 000

Black knob 400 series for VI 414

Electronic control

Set of 1 knob

Installation accessories

VA 420 004

Connection strip for combination with other Vario appliances of the 400 series for flush mounting

Special accessories

WP 400 001

Wok pan made of multiple-layer material With round bottom and handle, ø36 cm, 6 litres, height 10 cm.

WZ 400 000

Wok attachment for wok pan Only for Vario induction cooktops.

Vario induction cooktop 400 series

VI 414

- 32 cm cooking zone with booster function
- Solid stainless steel knob, also selectable with black robust finishing, for precise control and personalisation
- Frameless for flush mounting
- Ideal for the original wok pan with round bottom, with wok ring
- Can be combined perfectly with other Vario appliances of the 400 series

Cooking zones

1 induction cooking zone ø21 cm (2200 W, with booster 3700 W), automatically switches to ø26 cm (2600 W, with booster 3700 W) and to ø32 cm (3300 W, with booster 3700 W).

Handling

Control knobs with illuminated ring, cooking zone and output level markings. Electronic power control in 12 output levels. User friendly control with bicoloured display (white / orange).

Features

Frying sensor function.
Booster function.
Stopwatch.
Short-term timer.
Options menu.
Power management.

Selected digital services

(Home Connect)

Cooktop-based ventilation control (with suitable hood).
Remote monitoring.
Remote diagnostics.

Please read additional information on Home Connect on page 411.

Safety

Operation indicator.
Pot detection.
2-stage residual heat indication.
Safety shut-off.

Planning notes

The drawing "Installation of the control knob" must be observed if the panel is more than 23 mm thick (there must be a recess at the rear).

The bearing capacity and stability, in the case of thinner worktops in particular, must be supported using suitable substructures. Take into account the appliance weight and additional loads. Installation is possible in worktops made of stone, synthetics or solid wood. Heat resistance and watertight sealing of the cut edges must be observed. Concerning other materials please consult the worktop manufacturer. The groove must be continuous and even, so that uniform placing of the appliance on the gasket is ensured. Do not use discontinuous lining. The joint width may vary due to size tolerances of the combinations and of the worktop cut-out.

If installing several appliances in individual cut-outs allow for a division bar of minimum 50 mm between the individual cut-outs.

Operates with magnetic (induction) iron pots and pans only. For an optimal heat distribution, the use of sandwich bottom cookware is recommended.

Special accessories

(please order as spare parts):

Part No. 17006018

Frying sensor pan, ø20 cm

Part No. 17006184

Frying sensor pan, ø24 cm

Part No. 17006185

Frying sensor pan, ø28 cm

Part No. 17006019

Frying sensor pan, ø32 cm

Appliance can be snapped into the worktop from above.

Appliance weight: approx. 9 kg.

Please read the installation details regarding air ducting on page 210.

Please read additional planning notes on page 130 – 133.

Connection

Total connected load 3.7 kW.

Connecting cable 1.5 m without plug.

Connecting cables 0.3 m and 1 m for control knobs.

Power consumption standby/display off 0.5 W.

Power consumption standby/network 1.4 W.

Please check the user manual for how to switch off the WiFi module.

Length of connection cable, water in- and outlet see detailed drawing on page 115.



Installation of the cooktop; flush mounting

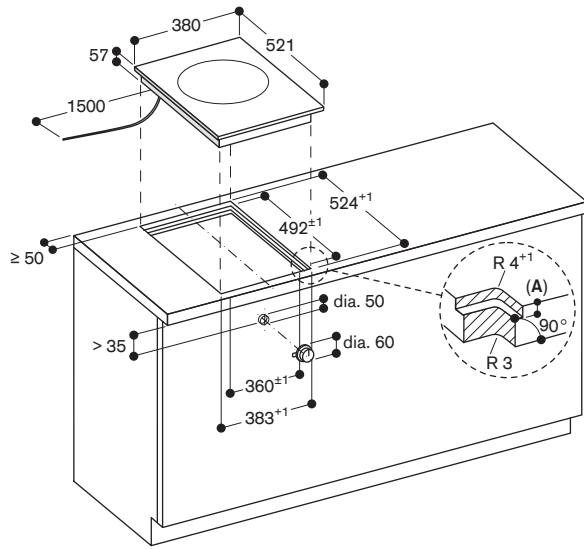

A: 6.5^{+0.5}

measurements in mm

View from above

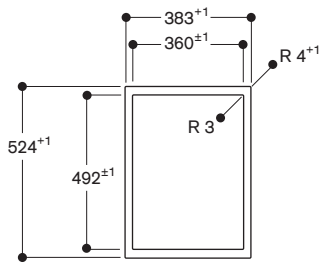

measurements in mm

Installation of the control knob

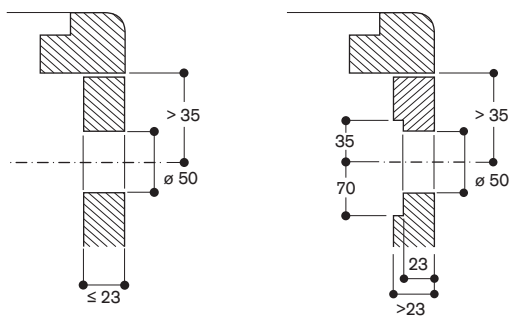

measurements in mm

Longitudinal section

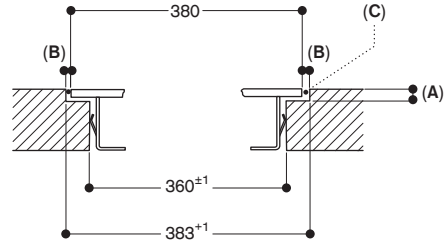

A: 6.5^{+0.5}

B: 1.5

C: Fill with silicone

measurements in mm

Cross-section

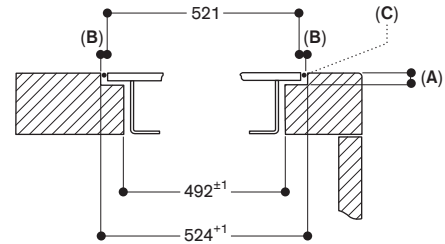

A: 6.5^{+0.5}

B: 1.5

C: Fill with silicone

measurements in mm



VI 414 115

Stainless steel frame

Width 38 cm

Knob needs to be ordered separately

Necessary installation accessories

CKI 410 010

Stainless steel knob 400 series for VI 414

Electronic control

Set of 1 knob

CKI 410 000

Black knob 400 series for VI 414

Electronic control

Set of 1 knob

Installation accessories

VA 420 004

Connection strip for combination with other Vario appliances of the 400 series for flush mounting

VA 420 010

Connection strip for combination with other Vario appliances of the 400 series for surface mounting

Special accessories

WP 400 001

Wok pan made of multiple-layer material With round bottom and handle, ø36 cm, 6 litres, height 10 cm.

WZ 400 000

Wok attachment for wok pan Only for Vario induction cooktops.

Vario induction cooktop 400 series

VI 414

- 32 cm cooking zone with booster function
- Solid stainless steel knob, also selectable with black robust finishing, for precise control and personalisation
- Precision crafted 3 mm stainless steel
- For surface mounting with a visible edge or for flush mounting
- Ideal for the original wok pan with round bottom, with wok ring
- Can be combined perfectly with other Vario appliances of the 400 series

Cooking zones

1 induction cooking zone ø 21 cm (2200 W, with booster 3700 W), automatically switches to ø 26 cm (2600 W, with booster 3700 W) and to ø 32 cm (3300 W, with booster 3700 W).

Handling

Control knobs with illuminated ring, cooking zone and output level markings. Electronic power control in 12 output levels.

User friendly control with bicoloured display (white / orange).

Features

Frying sensor function.

Booster function.

Stopwatch.

Short-term timer.

Options menu.

Power management.

Selected digital services

(Home Connect)

Cooktop-based ventilation control (with suitable hood).

Remote monitoring.

Remote diagnostics.

Please read additional information on Home Connect on page 411.

Safety

Operation indicator.

Pot detection.

2-stage residual heat indication.

Safety shut-off.

Planning notes

Depending on the type of installation (surface-mounted or flush-mounted), the specific location of the cut-out and the knob positions may vary.

The drawing "Installation of the control knob" must be observed if the panel is more than 23 mm thick (there must be a recess at the rear).

If combining several Vario appliances of the 400 series, a connection strip VA 420 must be placed between the appliances. Depending on the type of installation, the corresponding connection strip must be provided. The bearing capacity and stability, in the case of thin worktops in particular, must be supported using suitable substructures. Take into account the appliance weight and additional loads. Additional instructions for flush mounting: Installation is possible in worktops made of stone, synthetics or solid wood. Heat resistance and watertight sealing of the cut edges must be

observed. Concerning other materials please consult the worktop manufacturer. The groove must be continuous and even, so that uniform placing of the appliance on the gasket is ensured. Do not use discontinuous lining. The joint width may vary due to size tolerances of the combinations and of the worktop cut-out.

Please read additional planning notes on page 130 – 133.

If installing several appliances in individual cut-outs allow for a division bar of minimum 50 mm between the individual cut-outs.

Operates with magnetic (induction) iron pots and pans only. For an optimal heat distribution, the use of sandwich bottom cookware is recommended.

Special accessories

(please order as spare parts):

Part No. 17006018

Frying sensor pan, ø 20 cm

Part No. 17006184

Frying sensor pan, ø 24 cm

Part No. 17006185

Frying sensor pan, ø 28 cm

Part No. 17006019

Frying sensor pan, ø 32 cm

Appliance can be snapped into the worktop from above.

Appliance weight: approx. 10 kg.

Please read the installation details regarding air ducting on page 210.

Connection

Total connected load 3.7.

Connecting cable 1.5 without plug. Connecting cables 0.3m and 1 m for control knobs.

Power consumption standby/display off 0.5.

Power consumption standby/network 1.4.

Please check the user manual for how to switch off the WiFi module.



Installation of the cooktop; surface mounting

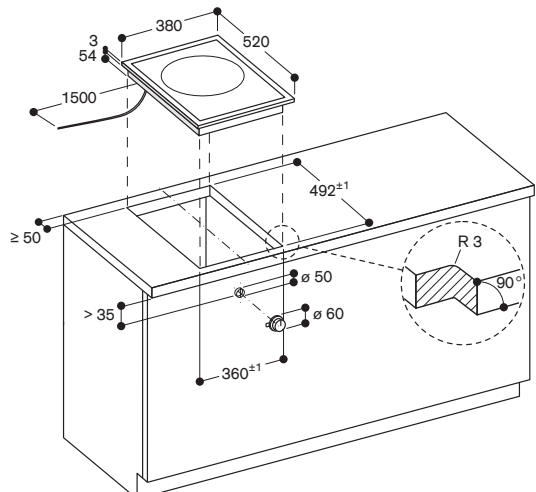

measurements in mm

Installation of the control knob

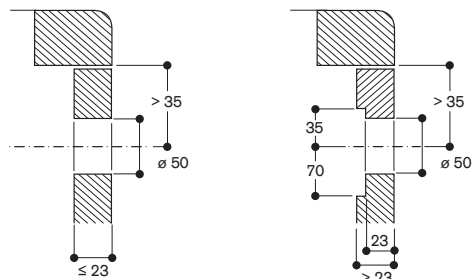

measurements in mm

Installation of the cooktop; flush mounting

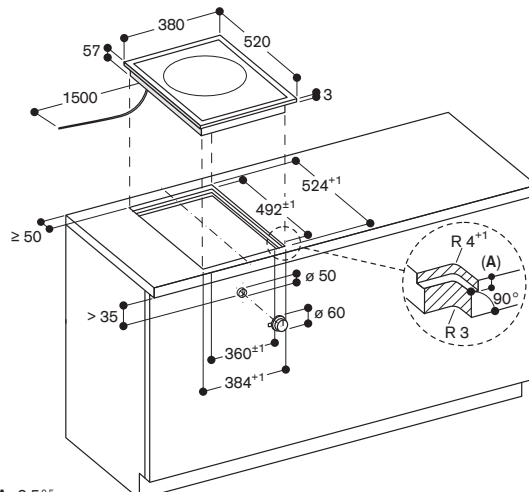

A: 3.5^{0.5}
measurements in mm

Installation of the control knob

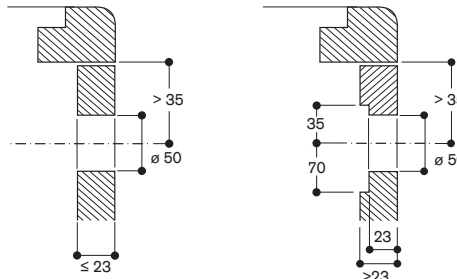

measurements in mm

View from above

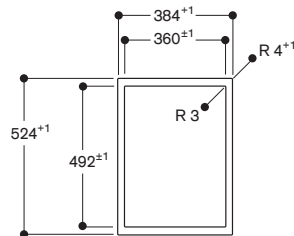

measurements in mm

Longitudinal section

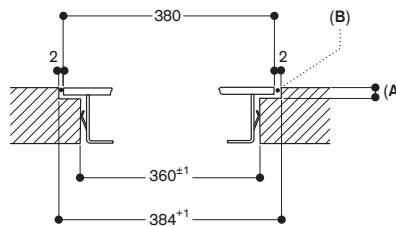

A: 3.5^{0.5}
B: Fill with silicone
measurements in mm

Cross-section

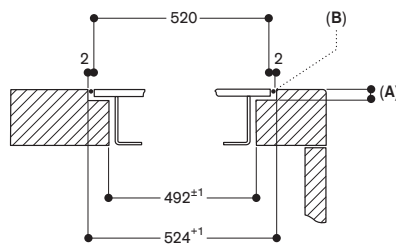

A: 3.5^{0.5}
B: Fill with silicone
measurements in mm



VG 491 115F

Stainless steel
Width 90 cm
Liquid gas 28 – 37 mbar
Knobs need to be ordered separately

VG 491 215

Stainless steel
Width 90 cm
Natural gas 20 mbar
Knobs need to be ordered separately

Included in the price

1 wok attachment ring

Necessary installation accessories

CKG 450 010

Stainless steel knobs 400 series for VG 491
Electronic control
Set of 5 knobs

CKG 450 000

Black knobs 400 series for VG 491
Electronic control
Set of 5 knobs

Installation accessories

VA 420 004

Connection strip for combination with other Vario appliances of the 400 series for flush mounting

VA 420 010

Connection strip for combination with other Vario appliances of the 400 series for surface mounting

Special accessories

WP 400 001

Wok pan made of multiple-layer material
With round bottom and handle,
ø 36 cm, 6 litres, height 10 cm.

Vario gas cooktop 400 series

VG 491

- Five multi-ring burners, up to 18 kW
- Full electronic power level regulation on 12 levels
- Solid stainless steel knob, also selectable with black robust finishing, for precise control and personalisation
- Precision crafted 3 mm stainless steel
- For surface mounting with a visible edge or for flush mounting
- Precise and reproducible flame size
- Automatic fast ignition, electronic flame monitoring with automatic re-ignition
- Simmer function for cooking on a very low output level
- Solid smooth-surface cast iron pan supports
- Can be combined perfectly with other Vario appliances of the 400 series

Cooking zones

VG 491 115F

1 multi-ring wok burner (300 – 5800), suitable for pots up to max. ø 32 cm.
2 two-ring high output burners (165 – 4000), suitable for pots up to max. ø 28 cm.
2 two-ring standard burners (165 – 2000), suitable for pots up to max. ø 24 cm.

VG 491 215

1 multi-ring wok burner (300 – 6000), suitable for pots up to max. ø 32 cm.
2 two-ring high output burners (165 – 4000), suitable for pots up to max. ø 28 cm.
2 two-ring standard burners (165 – 2000), suitable for pots up to max. ø 24 cm.

Handling

Control knobs with illuminated ring, cooking zone and output level markings.
One-handed operation.
Full electronic control in 12 output levels for exact power level regulation plus simmer function.
Automatic fast ignition.

Features

Simmer function.
Three-part cast iron pan support with flat, continuous pot surface.
Brass burner rings.

Safety

Electronic flame monitoring with automatic re-ignition.
Residual heat indication.
Safety shut-off.

Planning notes

Depending on the type of installation (surface-mounted or flush-mounted, with or without an appliance cover), the specific location of the cut-out and the knob positions may vary.
The horizontal positioning of the knobs may be aligned with the specific burners.
The drawing "Installation of the control knob" must be observed if the panel is more than 23 mm thick (there must be a recess at the rear).

If combining several Vario appliances of the 400 series, a connection strip VA 420 must be placed between the appliances. Depending on the type of installation, the corresponding connection strip must be provided. The bearing capacity and stability, in the case of thin worktops in particular, must be supported using suitable substructures. Take into account the appliance weight and additional loads. Additional instructions for flush mounting: Installation is possible in worktops made of stone, synthetics or solid wood. Heat resistance and watertight sealing of the cut edges must be observed. Concerning other materials please consult the worktop manufacturer. The groove must be continuous and even, so that uniform placing of the appliance on the gasket is ensured. Do not use discontinuous lining. The joint width may vary due to size tolerances of the combinations and of the worktop cut-out.

Please read additional planning notes on page 130 – 133.

If installing several appliances in individual cut-outs allow for a division bar of minimum 50 mm between the individual cut-outs.

Special nozzles can be ordered as spare parts.

Plan for an electrical connection (the appliance is not operable without power supply).

Air intake from above.

No intermediate shelf required.

Rear panel and wall trims must be heat-resistant and consist of a non-flammable material.

A minimum lateral clearance of at least 300 mm from adjacent heat-sensitive furniture or contact surfaces must be observed or thermal insulation fitted. Installation in a 90 cm wide lower cabinet is required.

With a total connected load of more than 11 kW local regulations concerning room ventilation, room size and combination of extraction or recirculation hoods must be observed. The minimum distance between the cooktop surface and a cabinet above, out of combustible material, needs to be 76 cm.

The minimum distance to a ventilation above is shown at the planning hints for the individual ventilation product.

The combination with VL 414 is not recommended, since the air extraction from the centre burner cannot be guaranteed due to the distance.

Appliance can be snapped into the worktop from above.

Appliance weight: approx. 31.

Connection

Total connected load gas
17.8/18.0 kW.

Total connected load electric
15.0/15.0 W.

Connecting cable 1.4 m with plug.
Connecting cables 0.3 m and 1 m for control knobs.

Installation of the cooktop; surface mounting

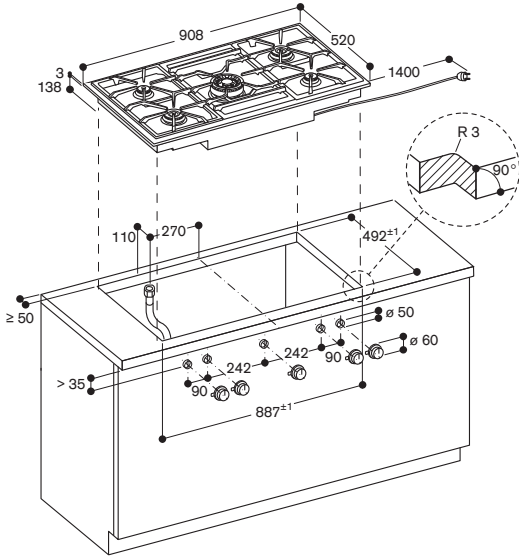

measurements in mm

Installation of the control knob

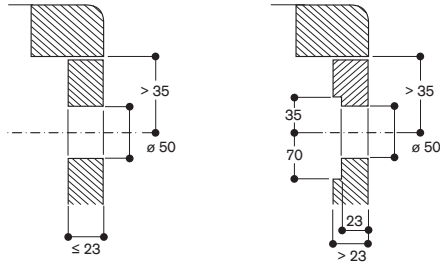

measurements in mm

Installation of the cooktop; flush mounting

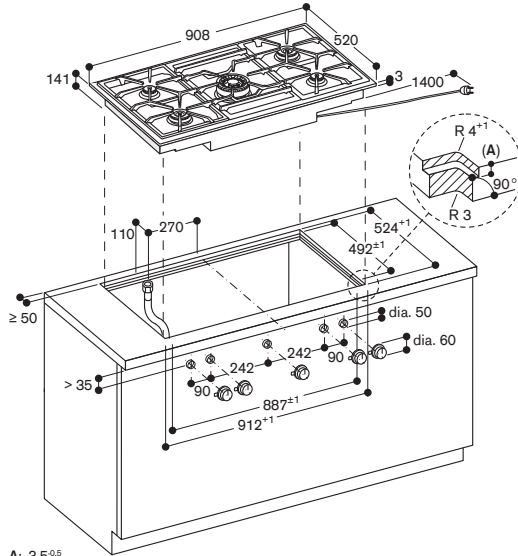

A: 3.5^{±0.5}
6.5^{±0.5} in combinations with frameless induction cooktops
measurements in mm

Installation of the control knob

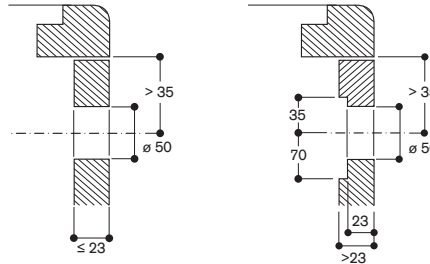

measurements in mm

View from above

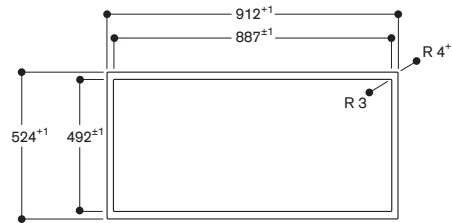

measurements in mm

Longitudinal section

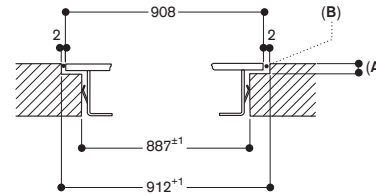

A: 3.5^{±0.5}
6.5^{±0.5} in combinations with frameless induction cooktops
B: Fill with silicone

measurements in mm

Cross-section

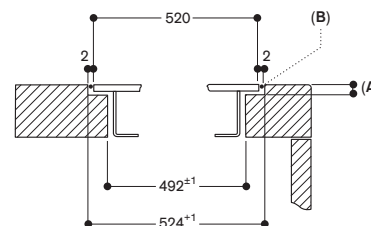

A: 3.5^{±0.5}
6.5^{±0.5} in combinations with frameless induction cooktops
B: Fill with silicone

measurements in mm



VG 415 115F

Stainless steel
Width 38 cm
Liquid gas 28 – 37 mbar
Wok burner with up to 5.8 kW
Knob needs to be ordered separately

VG 415 215

Stainless steel
Width 38 cm
Natural gas 20 mbar
Wok burner with up to 6 kW
Knob needs to be ordered separately

Included in the price

1 wok attachment ring

Necessary installation accessories

CKG 410 010

Stainless steel knob 400 series
for VG 415

Electronic control

Set of 1 knob

CKG 410 000

Black knob 400 series for VG 415

Electronic control

Set of 1 knob

Installation accessories

VA 420 004

Connection strip for combination with
other Vario appliances of the
400 series for flush mounting

VA 420 010

Connection strip for combination with
other Vario appliances of the
400 series for surface mounting

VA 440 010

Stainless steel appliance cover with
mounting strip

Special accessories

WP 400 001

Wok pan made of multiple-layer material
With round bottom and handle,
ø 36 cm, 6 litres, height 10 cm.

Vario gas wok 400 series

VG 415

- Multi-ring burner with up to 6 kW
- Full electronic power level regulation on 12 levels
- Solid stainless steel knob, also selectable with black robust finishing, for precise control and personalisation
- Precision crafted 3 mm stainless steel
- For surface mounting with a visible edge or for flush mounting
- Precise and reproducible flame size
- Automatic fast ignition, electronic flame monitoring with automatic re-ignition
- Simmer function for cooking on a very low output level
- Can be combined perfectly with other Vario appliances of the 400 series

Cooking zones

VG 415 115F

1 multi-ring wok burner
(300 W – 5800 W), suitable for pots
up to max. ø 32 cm.

VG 415 215

1 multi-ring wok burner
(300 W – 6000 W), suitable for pots up
to max. ø 32 cm.

Handling

Control knobs with illuminated ring,
cooking zone and output level markings.
One-handed operation.
Full electronic control in 12 output
levels for exact power level regulation
plus simmer function.
Automatic fast ignition.

Features

Simmer function.
Cast iron pan support with flat,
continuous pot surface.
Brass burner rings.

Safety

Electronic flame monitoring with
automatic re-ignition.
Residual heat indication.
Safety shut-off.

Planning notes

Depending on the type of installation
(surface-mounted or flush-mounted,
with or without an appliance cover), the
specific location of the cut-out and the
knob positions may vary.

The drawing "Installation of the control
knob" must be observed if the panel is
more than 23 mm thick (there must be
a recess at the rear).

If combining several Vario appliances
of the 400 series, a connection strip
VA 420 must be placed between the
appliances. Depending on the type of
installation, the corresponding
connection strip must be provided.
The bearing capacity and stability, in
the case of thin worktops in particular,
must be supported using suitable
substructures. Take into account the
appliance weight and additional loads.
Additional instructions for flush mounting:
Installation is possible in worktops
made of stone, synthetics or solid
wood. Heat resistance and watertight
sealing of the cut edges must be
observed. Concerning other materials
please consult the worktop manufacturer.

The groove must be continuous and
even, so that uniform placing of the
appliance on the gasket is ensured.
Do not use discontinuous lining.
The joint width may vary due to size
tolerances of the combinations and of
the worktop cut-out.

Please read additional planning notes
on page 130 – 133.

If installing several appliances in
individual cut-outs allow for a division
bar of minimum 50 mm between the
individual cut-outs.

Special nozzles can be ordered as
spare parts.

Plan for an electrical connection (the
appliance is not operable without
power supply).

Air intake from above.

No intermediate shelf required.

Rear panel and wall trims must be
heat-resistant and consist of a
non-flammable material.

A minimum clearance of at least
150 mm from adjacent heat-sensitive
furniture or contact surfaces must be
observed or thermal insulation fitted.
If operated next to the downdraft
ventilation VL 414, the ventilation
moulding AA 414 is recommended to
ensure maximum performance of the
cooktop.

With a total connected load of more
than 11 kW local regulations
concerning room ventilation, room size
and combination of extraction or
recirculation hoods must be observed.
The minimum distance between the
cooktop surface and a cabinet above,
out of combustible material, needs to
be 70 cm.

The minimum distance to a ventilation
above is shown at the planning hints
for the individual ventilation product.
Appliance can be snapped into the
worktop from above.

Appliance weight: approx. 15 kg.

Connection

Total connected load gas 5.8/6.0 kW.

Total connected load electric

15.0/15.0 W.

Connecting cable 1.4 m with plug.

Connecting cables 0.3 m and 1 m for
control knobs.

Installation of the cooktop; surface mounting

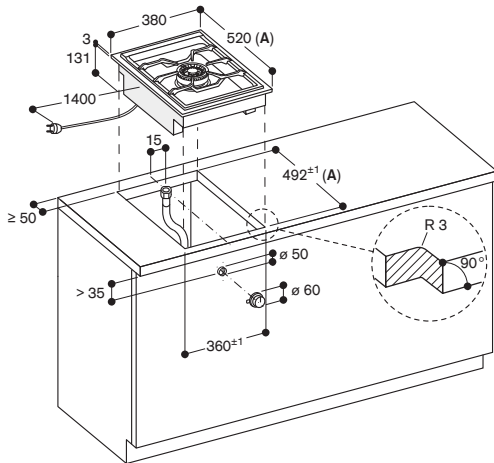

A: When installing with appliance cover, take the deeper cut-out into consideration (observe separate planning notes)

measurements in mm

Installation of the control knob

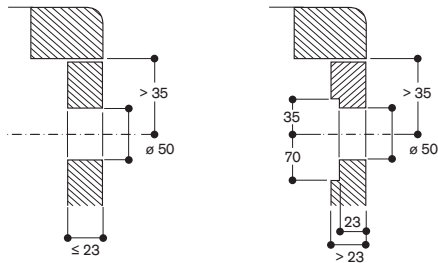

measurements in mm

Installation of the cooktop; flush mounting

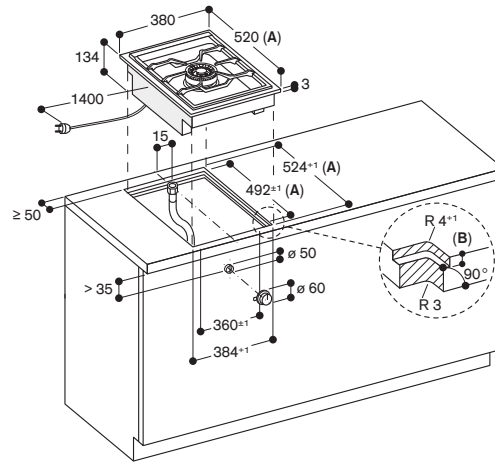

A: When installing with appliance cover consider the deeper cut-out (observe separate planning notes)

B: 3.5^{+0.5} mm
6.5^{+0.5} mm in combinations with frameless induction cooktops

Measurements in mm

Installation of the control knob

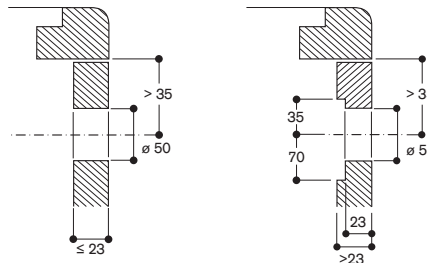

measurements in mm

View from above

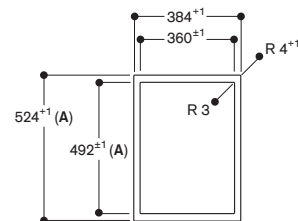

A: When installing with appliance cover, take the deeper cut-out into consideration (observe separate planning notes)

measurements in mm

Longitudinal section

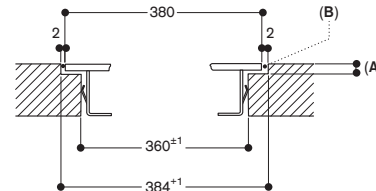

A: 3.5^{+0.5} mm
6.5^{+0.5} mm in combinations with frameless induction cooktops
B: Fill with silicone

measurements in mm

Cross-section

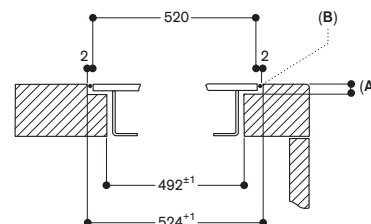

A: 3.5^{+0.5} mm
6.5^{+0.5} mm in combinations with frameless induction cooktops
B: Fill with silicone

When installing with appliance cover, pay attention to the deeper cut-out and the front and rear groove width.

measurements in mm



VG 425 115F

Stainless steel
Width 38 cm
Liquid gas 28 – 37 mbar
Knobs need to be ordered separately

VG 425 215

Stainless steel
Width 38 cm
Natural gas 20 mbar
Knobs need to be ordered separately

Necessary installation accessories

CKG 420 010

Stainless steel knobs 400 series for VG 425
Electronic control
Set of 2 knobs

CKG 420 000

Black knobs 400 series for VG 425
Electronic control
Set of 2 knobs

Installation accessories

VA 420 004

Connection strip for combination with other Vario appliances of the 400 series for flush mounting

VA 420 010

Connection strip for combination with other Vario appliances of the 400 series for surface mounting

VA 440 010

Stainless steel appliance cover with mounting strip

Vario gas cooktop 400 series

VG 425

- Multi-ring burner with up to 4 kW
- Full electronic power level regulation on 12 levels
- Solid stainless steel knob, also selectable with black robust finishing, for precise control and personalisation
- Precision crafted 3 mm stainless steel
- For surface mounting with a visible edge or for flush mounting
- Precise and reproducible flame size
- Automatic fast ignition, electronic flame monitoring with automatic re-ignition
- Simmer function for cooking on a very low output level
- Solid smooth-surface cast iron pan supports
- Can be combined perfectly with other Vario appliances of the 400 series

Cooking zones

VG 425 115F

1 two-ring high output burner (165 W – 4000 W), suitable for pots up to max. ø 28 cm.

1 two-ring standard output burner (165 W – 2000 W), suitable for pots up to max. ø 24 cm.

VG 425 215

1 two-ring high output burner (165 W – 4000 W), suitable for pots up to max. ø 28 cm.

1 two-ring standard output burner (165 W – 2000 W), suitable for pots up to max. ø 24 cm.

Handling

Control knobs with illuminated ring, cooking zone and output level markings. One-handed operation.

Full electronic control in 12 output levels for exact power level regulation plus simmer function. Automatic fast ignition.

Features

Simmer function.
Cast iron pan support with flat, continuous pot surface.
Brass burner rings.

Safety

Electronic flame monitoring with automatic re-ignition.
Residual heat indication.
Safety shut-off.

Planning notes

Depending on the type of installation (surface-mounted or flush-mounted, with or without an appliance cover), the specific location of the cut-out and the knob positions may vary.

The drawing "Installation of the control knob" must be observed if the panel is more than 23 mm thick (there must be a recess at the rear).

If combining several Vario appliances of the 400 series, a connection strip VA 420 must be placed between the appliances. Depending on the type of installation, the corresponding connection strip must be provided. The bearing capacity and stability, in the case of thin worktops in particular, must be supported using suitable substructures. Take into account the appliance weight and additional loads. Additional instructions for flush mounting: Installation is possible in worktops made of stone, synthetics or solid wood. Heat resistance and watertight sealing of the cut edges must be observed. Concerning other materials please consult the worktop manufacturer. The groove must be continuous and even, so that uniform placing of the appliance on the gasket is ensured. Do not use discontinuous lining. The joint width may vary due to size tolerances of the combinations and of the worktop cut-out.

Please read additional planning notes on page 130 – 133.

If installing several appliances in individual cut-outs allow for a division bar of minimum 50 mm between the individual cut-outs.

Special nozzles can be ordered as spare parts.

Plan for an electrical connection (the appliance is not operable without power supply).

Air intake from above.

No intermediate shelf required.

Rear panel and wall trims must be heat-resistant and consist of a non-flammable material.

A minimum clearance of at least 150 mm from adjacent heat-sensitive furniture or contact surfaces must be observed or thermal insulation fitted. If operated next to the downdraft ventilation VL 414, the air baffle AA 414 is recommended to ensure maximum performance of the cooktop.

With a total connected load of more than 11 kW local regulations concerning room ventilation, room size and combination of extraction or recirculation hoods must be observed. The minimum distance between the cooktop surface and a cabinet above, out of combustible material, needs to be 70 cm.

The minimum distance to a ventilation above is shown at the planning hints for the individual ventilation product. Appliance can be snapped into the worktop from above.

Appliance weight: approx. 14 kg.

Connection

Total connected load gas 6.0/6.0 kW.

Total connected load electric 15.0/15.0 W.

Connecting cable 1.4 m with plug.

Connecting cables 0.3 m and 1 m for control knobs.

Installation of the cooktop; surface mounting

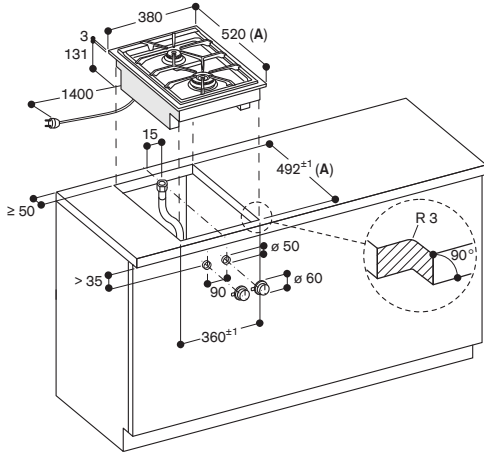

A: When installing with appliance cover, take the deeper cut-out into consideration (observe separate planning notes)

measurements in mm

Installation of the control knob

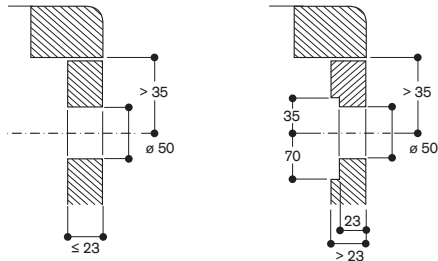

measurements in mm

Installation of the cooktop; flush mounting

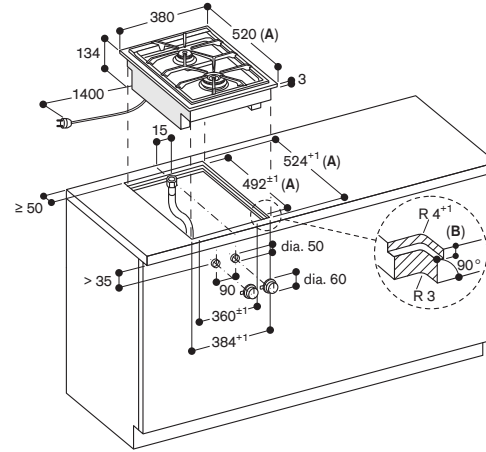

A: When installing with appliance cover consider the deeper cut-out (observe separate planning notes)

B: 3.5^{+0.5} in combinations with frameless induction cooktops

measurements in mm

Installation of the control knob

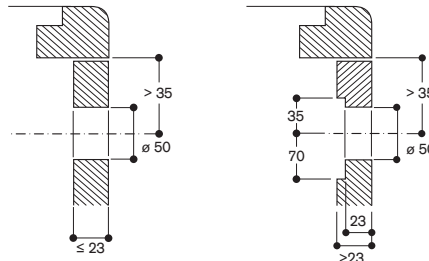

measurements in mm

View from above

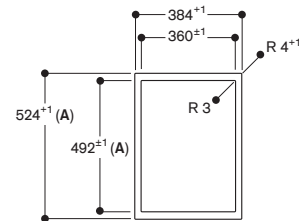

A: When installing with appliance cover, take the deeper cut-out into consideration (observe separate planning notes)

measurements in mm

Longitudinal section

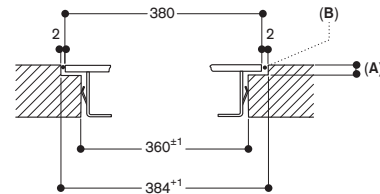

A: 3.5^{+0.5}
6.5^{+0.5} in combinations with frameless induction cooktops

B: Fill with silicone

measurements in mm

Cross-section

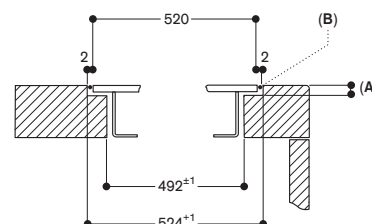

A: 3.5^{+0.5}
6.5^{+0.5} in combinations with frameless induction cooktops

B: Fill with silicone

When installing with appliance cover, pay attention to the deeper cut-out and the front and rear groove width.

measurements in mm



VP 414 115

Stainless steel
Width 38 cm
Knobs need to be ordered separately

Included in the price

2 spatula

Necessary installation accessories

CKP 420 010

Stainless steel knobs 400 series
for VP 414
Electronic control
Set of 2 knobs

CKP 420 000

Black knobs 400 series for VP 414
Electronic control
Set of 2 knobs

Installation accessories

VA 420 004

Connection strip for combination with
other Vario appliances of the
400 series for flush mounting

VA 420 010

Connection strip for combination with
other Vario appliances of the
400 series for surface mounting

VA 440 010

Stainless steel appliance cover with
mounting strip

Vario Teppan Yaki 400 series

VP 414

- Cooking directly on the hard-chromed metal surface, without any pots or pans
- Exact temperature control up to 240 °C
- Optimum heat distribution
- Solid stainless steel knob, also selectable with black robust finishing, for precise control and personalisation
- Precision crafted 3 mm stainless steel
- For surface mounting with a visible edge or for flush mounting
- Can be combined perfectly with other Vario appliances of the 400 series

Cooking zones

Usable area W 31 x D 44 cm.

Handling

Control knobs with illuminated ring, cooking zone and temperature markings.

Electronic temperature control from 120 °C to 240 °C.

Features

Two zones, each 1500 W, can be operated together as a complete surface or each half separately. Keeping warm setting. Cleaning stage. Even with traces of use, always easy to clean like a cast pan.

Safety

Safety shut-off.
Pre-heat and residual heat indicator.

Planning notes

Depending on the type of installation (surface-mounted or flush-mounted, with or without an appliance cover), the specific location of the cut-out and the knob positions may vary.

If combining several Vario appliances of the 400 series, select combinations with or without appliance cover, and a connection strip VA 420 must be placed between the appliances.

Depending on the type of installation, the corresponding connection strip must be provided.

The bearing capacity and stability, in the case of thinner worktops in particular, must be supported using suitable substructures. Take into account the appliance weight and additional loads. Additional instructions for flush mounting: Installation is possible in worktops made of stone, synthetics or solid wood. Heat resistance and watertight sealing of the cut edges must be observed. Concerning other materials please consult the worktop manufacturer. The groove must be continuous and even, so that uniform placing of the appliance on the gasket is ensured. Do not use discontinuous lining.

The joint width may vary due to size tolerances of the combinations and of the worktop cut-out.

Please read additional planning notes on page 130 – 133.

If installing several appliances in individual cut-outs allow for a division bar of minimum 50 mm between the individual cut-outs. A minimum lateral clearance of at least 40 mm from adjacent heat-sensitive furniture or contact surfaces must be observed or thermal insulation fitted. Appliance can be snapped into the worktop from above. Appliance weight: approx. 12 kg.

Connection

Total connected load 3.0 kW.
Connecting cable 1.5 m without plug.
Connecting cables 0.3 m and 1 m for control knobs.



Installation of the cooktop; surface mounting

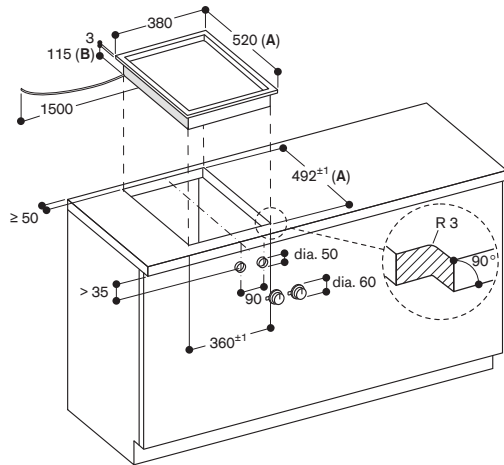

A: When installing with appliance cover, take the deeper cut-out into consideration (observe separate planning notes)
 B: 130 mm in the area of the cable clamp (left, on the rear side)

measurements in mm

Installation of the control knob

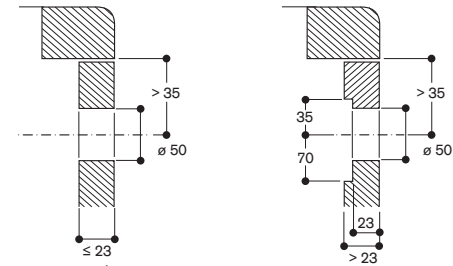

measurements in mm

Installation of the cooktop; flush mounting

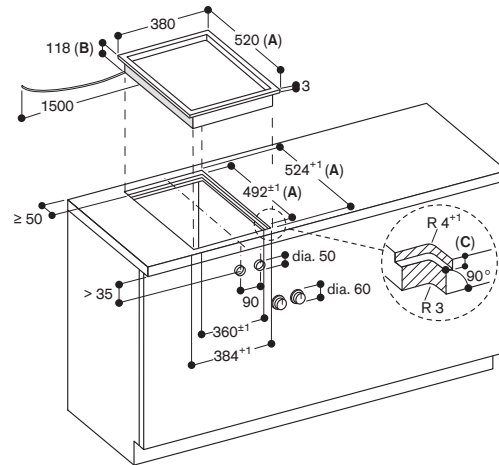

A: When installing with appliance cover consider the deeper cut-out (observe separate planning notes)
 B: 133 mm in the area of the cable clamp (left, on the rear side)
 C: 3.5^{-0.5}

6.5^{-0.5} in combinations with frameless induction cooktops

measurements in mm

Installation of the control knob

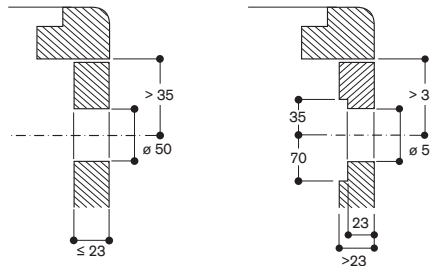

measurements in mm

View from above

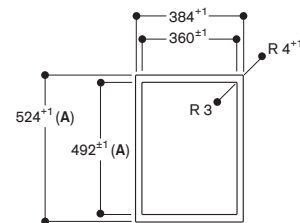

measurements in mm

Longitudinal section

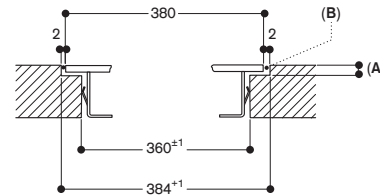

A: 3.5^{-0.5}
 6.5^{-0.5} in combinations with frameless induction cooktops
 B: Fill with silicone

measurements in mm

Cross-section

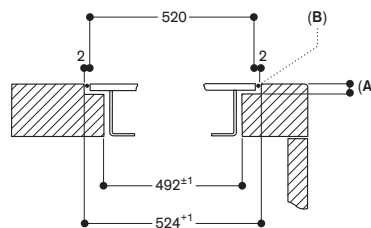

A: 3.5^{-0.5}
 B: Fill with silicone

measurements in mm



VR 414 115

Stainless steel
Width 38 cm
Knobs need to be ordered separately

Included in the price

- 1 cast pan, half size
- 2 cast grills
- 1 lava stone
- 1 cleaning brush

Necessary installation accessories

CKR 420 010

Stainless steel knobs 400 series for VR 414

Electronic control
Set of 2 knobs

CKR 420 000

Black knobs 400 series for VR 414
Electronic control
Set of 2 knobs

Installation accessories

VA 420 004

Connection strip for combination with other Vario appliances of the 400 series for flush mounting

VA 420 010

Connection strip for combination with other Vario appliances of the 400 series for surface mounting

VA 440 010

Stainless steel appliance cover with mounting strip

Special accessories

LV 030 000

Lava stone for refilling

Vario electric grill 400 series

VR 414

- Two zones can be operated together or separately
- Cast pan, half size, for simultaneous frying and grilling on two separate surfaces
- Open cast grill, lava stone
- Solid stainless steel knob, also selectable with black robust finishing, for precise control and personalisation
- Precision crafted 3 mm stainless steel
- For surface mounting with a visible edge or for flush mounting
- Can be combined perfectly with other Vario appliances of the 400 series

Handling

Control knobs with illuminated ring, cooking zone and output level markings. Electronic control in 12 output levels.

Features

Cooktop, lava stone trough and grease collecting insert from stainless steel. Two zones, each 1500 W, can be operated together as a complete surface or each half separately. Two-part cast grill.

Safety

Safety shut-off.
Pre-heat and residual heat indicator.

Planning notes

Depending on the type of installation (surface-mounted or flush-mounted, with or without an appliance cover), the specific location of the cut-out and the knob positions may vary.

If installing with the appliance cover VA 440 take into account the additional space required for the depth.

If combining several Vario appliances of the 400 series, select combinations with or without appliance cover, and a connection strip VA 420 must be placed between the appliances. Depending on the type of installation, the corresponding connection strip must be provided.

The bearing capacity and stability, in the case of thinner worktops in particular, must be supported using suitable substructures. Take into account the appliance weight and additional loads. Additional instructions for flush mounting: Installation is possible in worktops made of stone, synthetics or solid wood. Heat resistance and watertight sealing of the cut edges must be observed. Concerning other materials please consult the worktop manufacturer. The groove must be continuous and even, so that uniform placing of the appliance on the gasket is ensured. Do not use discontinuous lining. The joint width may vary due to size tolerances of the combinations and of the worktop cut-out.

Please read additional planning notes on page 130 – 133.

If installing several appliances in individual cut-outs allow for a division bar of minimum 50 mm between the individual cut-outs.

A minimum lateral clearance of at least 100 mm from adjacent heat-sensitive furniture or from the wall must be observed.

Appliance can be snapped into the worktop from above.

Appliance weight: approx. 26 kg.

Connection

Total connected load 3.0 kW.
Connecting cable 1.5 m without plug.
Connecting cables 0.3 m and 1 m for control knobs.



Installation of the cooktop; surface mounting

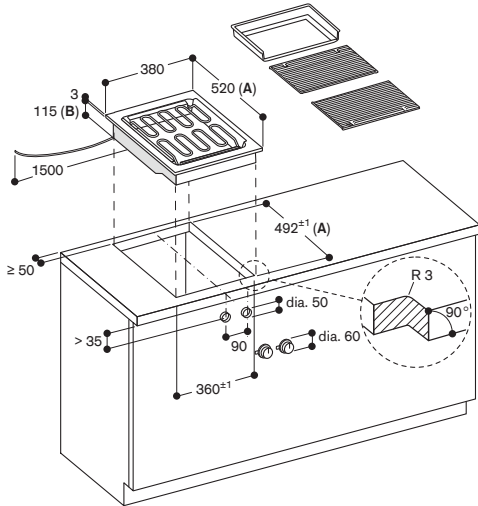

A: When installing with appliance cover, take the deeper cut-out into consideration (observe separate planning notes)
 B: 130 mm in the area of the cable clamp (left, on the rear side)

measurements in mm

Installation of the control knob

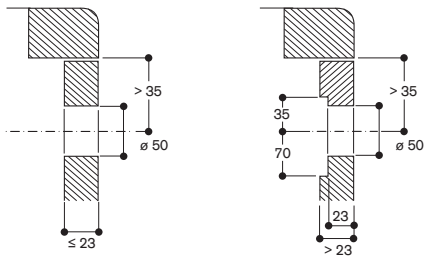

measurements in mm

Installation of the cooktop; flush mounting

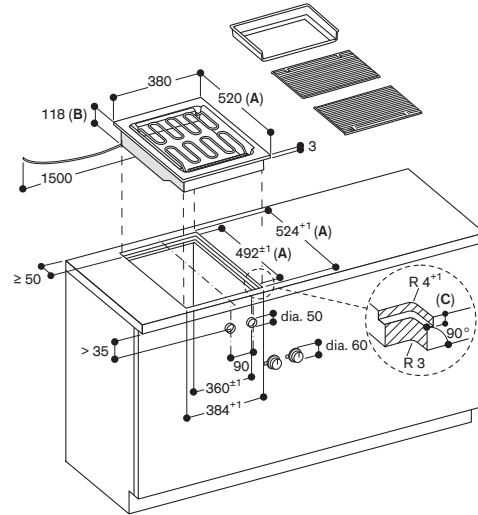

A: When installing with appliance cover consider the deeper cut-out (observe separate planning notes)
 B: 133 mm in the area of the cable clamp (left, on the rear side)
 C: 3.5^{-0.5}

6.5^{+0.5} in combinations with frameless induction cooktops
 measurements in mm

Installation of the control knob

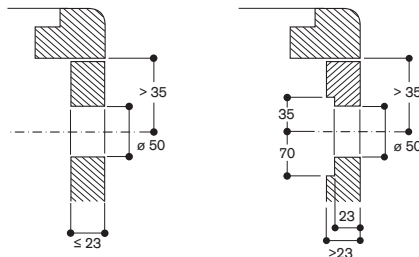

measurements in mm

View from above

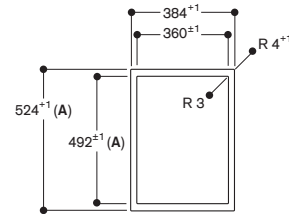

A: When installing with appliance cover take the deeper cut-out into consideration (observe separate planning notes)

measurements in mm

Longitudinal section

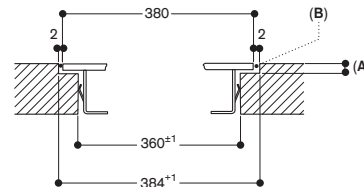

A: 3.5^{-0.5}
 6.5^{+0.5} in combinations with frameless induction cooktops
 B: Fill with silicone

measurements in mm

Cross-section

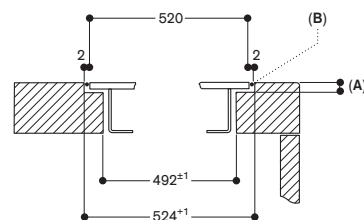

A: 3.5^{-0.5}
 6.5^{+0.5} in combinations with frameless induction cooktops
 B: Fill with silicone

When installing with appliance cover, pay attention to the deeper cut-out and the front and rear groove width.

measurements in mm



VL 414 115
 stainless steel
 Width 15.5 cm
 Air extraction / Air recirculation
 Motorless
 Knob needs to be ordered separately



Necessary installation accessories

CKV 410 010
 Stainless steel knob 400 series
 for VL 414
 Electronic control
 Set of 1 knob

CKV 410 000
 Black knob 400 series for VL 414
 Electronic control
 Set of 1 knob

In combination with remote fan units

AR 400 142
 AR 401 142
 AR 403 122
 AR 413 122
 AR 410 110

Installation accessories

AD 410 040
 Flexibel connecting piece
 DN 150 flat

AD 851 041
 Connecting piece for extension with
 flat duct DN 150 for extra deep worktop

VA 420 004
 Connection strip for combination with
 other Vario appliances of the 400 series
 for flush mounting

VA 420 010
 Connection strip for combination with
 other Vario appliances of the 400 series
 for surface mounting

Special accessories

AA 400 510
 Window contact switch

AA 414 010
 Ventilation moulding for VL 414 next to
 gas appliance.

Installation accessories for air ducting
 you will find at the pages 287 – 293.

Vario downdraft ventilation 400 series VL 414

- Highly efficient, low noise ventilation system especially with remote fan unit AR 410 110
- Function for automatic, sensor-controlled power adjustment depending on the build-up of cooking vapours
- Minimal planning and easy installation
- Solid stainless steel knob, also selectable with black robust finishing, for precise control and personalisation
- Precision crafted 3 mm stainless steel
- For surface mounting with a visible edge or for flush mounting
- Can be combined perfectly with other Vario appliances of the 400 series

Output

Power levels depend on the remote fan unit.

Refer to the "Technical specifications" of the hood for the matching remote fan units for air recirculation or air extraction mode.

Features

Control knob with illuminated ring.
 3 electronically controlled power levels and 1 intensive mode.

Automatic sensor-controlled performance adjustment of the ventilation system.

Automatic sensor controlled or manual run on function.

Large-scale metal grease filter with high grease absorption.

Removable, dishwasher-safe grease filter unit.

Grease filter and activated charcoal filter saturation indicator.

Airflow-optimised interior for efficient air circulation.

Interval ventilation, 6 min.

Enamelled ventilation grille, dishwasher-safe.

Air exhaust bend included in delivery.

Overflow 250 ml capacity.

Selected digital services (Home Connect)

Cooktop-based ventilation control (with suitable cooktop).

Remote control and monitoring

Remote diagnostics

Please read additional information on Home Connect on page 411.

Consumption data

Consumption data is referred to a configuration with the remote fan unit AR 403 122.

Energy efficiency class A+ at a range of energy efficiency classes from A+++ to D.

Energy consumption 40.4 kWh/year.

Ventilation efficiency class A.

Illumination efficiency class -.

Grease filter efficiency class B.

Sound level min. 57 dB / max. 71 dB normal mode.

Planning notes

The equivalent ducting length to ensure good performance is Lmax 26 m. For each VL one remote fan unit is recommended.

Maximum cooktop(s) width between two VL: 80 cm except with the CX 482. Vario cooktops like Vario electric grill and Vario gas wok should be placed between 2 VL.

In case of Vario electric grill, recirculation is not recommended. If operated next to gas appliances, the ventilation moulding AA 414 010 is recommended to ensure maximum performance of the cooktop.

Appliance can be snapped into the worktop from above.

Depending on the type of installation (surface-mounted or flush-mounted), the specific location of the cut-out and the knob positions may vary.

If combining several Vario appliances of the 400 series, a connection strip VA 420 must be placed between the appliances. Depending on the type of installation, the corresponding connection strip must be provided.

The bearing capacity and stability, in the case of thin worktops in particular, must be supported using suitable substructures. Take into account the appliance weight and additional loads.

Additional instructions for flush mounting:

Installation is possible in worktops made of stone, synthetics or solid wood. Heat resistance and watertight sealing of the cut edges must be observed. Concerning other materials please consult the worktop manufacturer. The groove must be continuous and even, so that uniform placing of the appliance on the gasket is ensured. Do not use discontinuous lining.

The joint width may vary due to size tolerances of the combinations and of the worktop cut-out.

When installing a ventilation hood with air extraction mode and a chimney-vented fireplace, the power supply line of the ventilation appliance needs a suitable safety switch.

Please read additional planning notes on page 256 – 259.

Connection

Total connected load 10 W.

Connecting cable 1.75 m, pluggable.

Connecting cables 0.3m and 1 m for control knobs.

Plan a LAN cable.

*Energy efficiency class: at a range of energy efficiency classes from A+++ to D.

**Installation of the downdraft ventilation;
surface mounting**

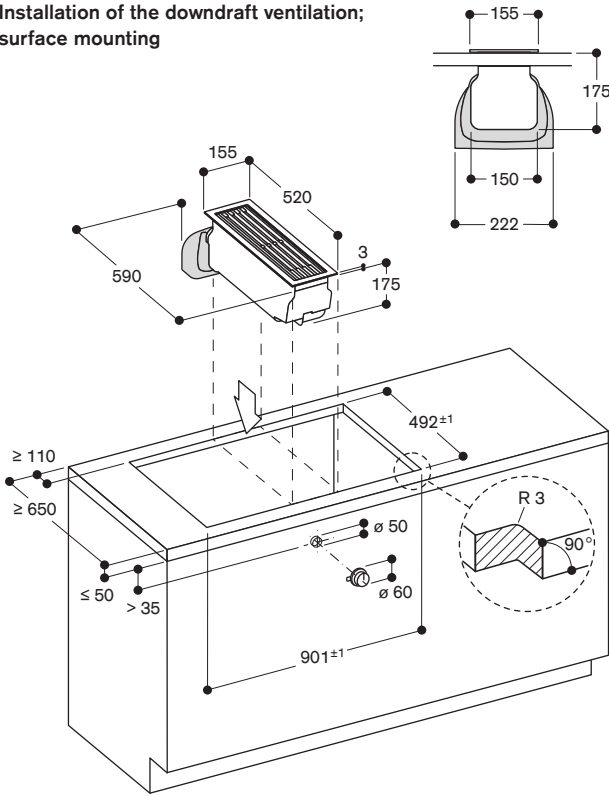

measurements in mm

Installation of the control knob

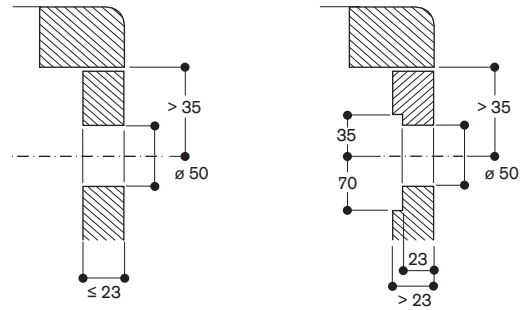

measurements in mm

**Installation of the downdraft ventilation;
flush mounting**

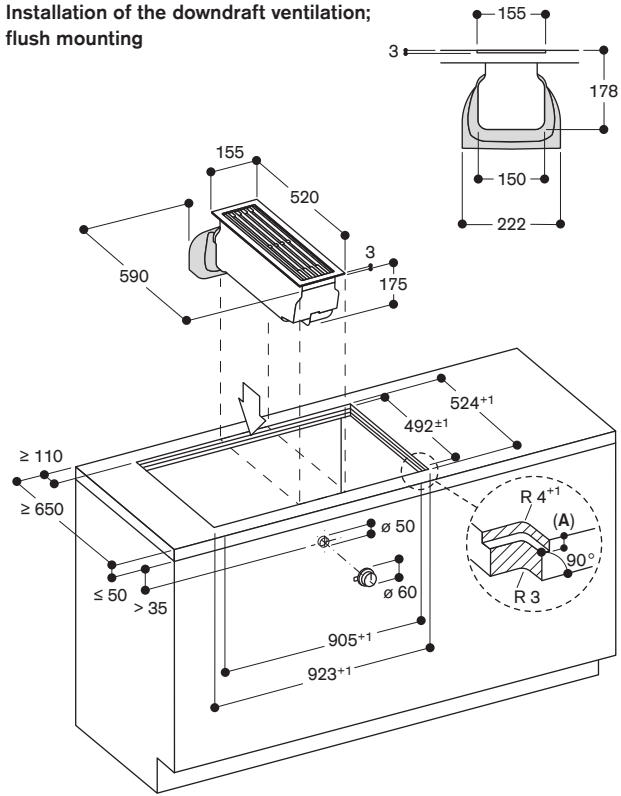

A: 3.5^{+0.5} in combination with at least one framed appliance
6.5^{+0.5} in combination with at least one frameless induction cooktop

measurements in mm

Installation of the control knob

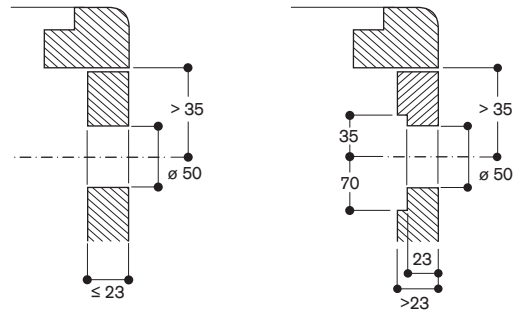

measurements in mm

Installation accessories

AD 410 040 : Flexibel connecting piece, DN 150 flat

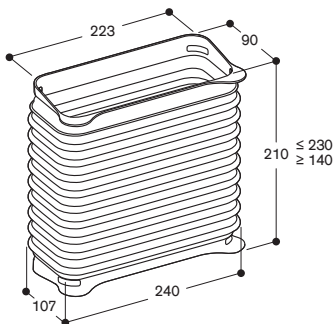

measurements in mm

AD 851 041: Connecting piece VL for extension with flat duct DN150 for extra deep worktop

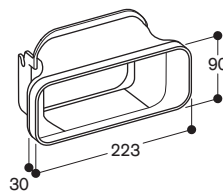

Sample combinations without VL 414 ventilation element for flush mounting.

Cut-out dimensions for appliance combinations in the 400 series for flush mounting. The technician can find the suitable cut-out dimensions for the combinations most frequently used by referring to the previous pages and the drawings below

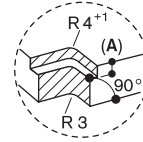
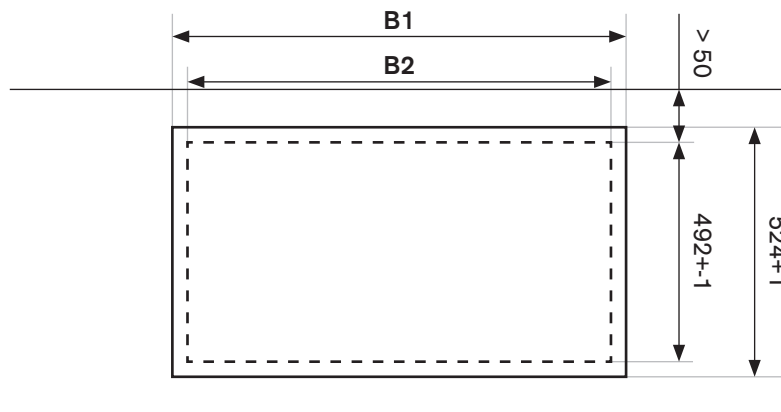

For dimension A:
 3,5 – 0,5 in combinations with only framed appliances
 6,5 +0,5 in combinations with at least one frameless induction cooktops

Cooktops	Appliances size [mm]	Dimension B1 [mm]	Dimension B2 [mm]	# of VA420004
	380 / 380	766 +1	748 +-1	1
	380 / 380 / 380	1148 +1	1130 +-1	2
	380 / 380 / 380 / 380	1530 +1	1512 +-1	3
	591 / 380	977 +1	959 +-1	1
	380 / 591 / 380	1359 +1	1341 +-1	2
	805 / 380	1191 +1	1173 +-1	1
	909 / 380	1295 +1	1277 +-1	1

Cut-out dimensions for appliance combinations in the 400 series for flush mounting. The technician can find the suitable cut-out dimensions for the combinations most frequently used by referring to the previous pages and the drawings below

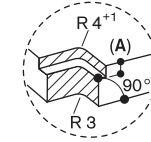
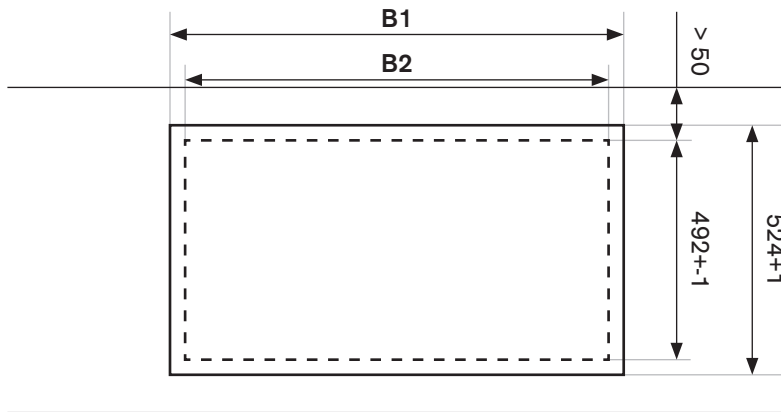

For dimension A:
 3,5 – 0,5 in combinations with only framed appliances
 6,5 +0,5 in combinations with at least one frameless induction cooktops





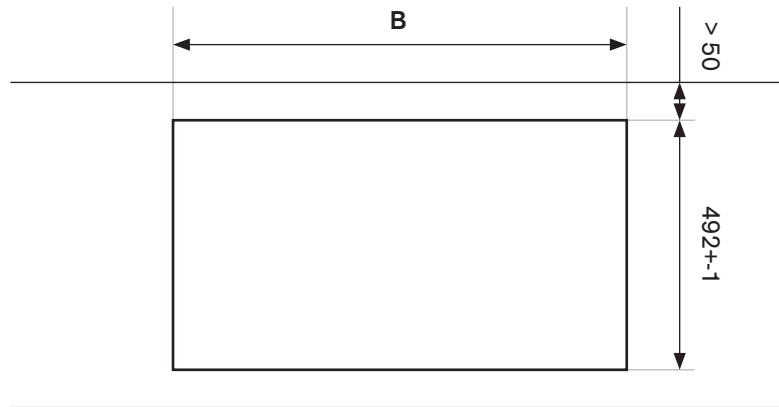

Cooktops	Appliances size [mm]	Dimension B1 [mm]	Dimension B2 [mm]	# of VA420004
	380 / 155 / 380	923 +1	905 +-1	2
	380 / 155 / 380 / 155	1080 +1	1062 +-1	3
	380 / 155 / 380 / 155 / 380	1462 +1	1444 +-1	4
	380 / 155 / 380 / 155 / 380 / 155 / 380	2001 +1	1983 +-1	6
	380 / 155 / 380 / 380 / 155 / 380	1844 +1	1826 +-1	5
	155 / 591 / 155	909 +1	891 +-1	2
	155 / 591 / 155 / 380	1291 +1	1273 +-1	3
	380 / 155 / 591 / 155 / 380	1673 +1	1655 +-1	4
	380 / 155 / 805 / 155 / 380	1887 +1	1869 +-1	4

Recommended position for gas wok and grill

Sample combinations without VL 414 ventilation element for surface mounting.

Cut-out dimensions for appliance combinations in the 400 series for Surface mounting. The technician can find the suitable cut-out dimensions for the combinations most frequently used by referring to the previous pages and the drawings below

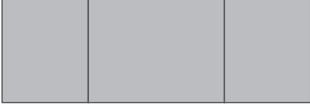

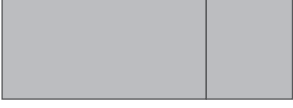
Cooktops	Appliances size [mm]	Dimension B [mm]	# of VA420010
	380 / 380	743 +-1	1
	380 / 380 / 380	1126 +-1	2
	380 / 380 / 380 / 380	1509 +-1	3
	590 / 380	953 +-1	1
	380 / 590 / 380	1336 +-1	2
	804 / 380	1167 +-1	1
	908 / 380	1271 +-1	1

Cut-out dimensions for appliance combinations in the 400 series for Surface mounting. The technician can find the suitable cut-out dimensions for the combinations most frequently used by referring to the previous pages and the drawings below

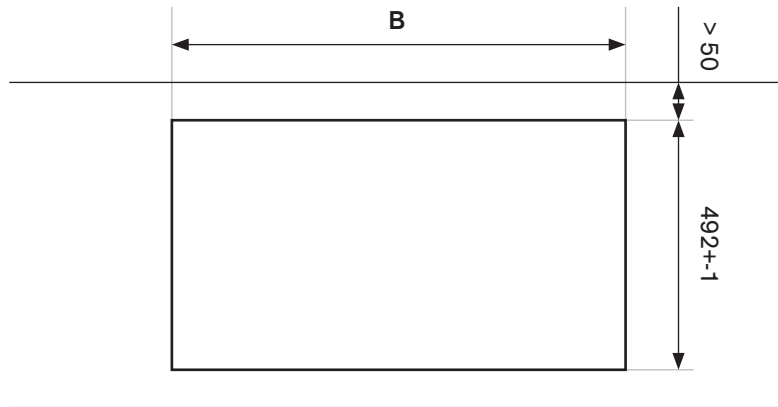

Cooktops	Appliances size [mm]	Dimension B [mm]	# of VA420010
	380 / 155 / 380	901 +1	2
	380 / 155 / 380 / 155	1059 +1	3
	380 / 155 / 380 / 155 / 380	1442 +1	4
	380 / 155 / 380 / 155 / 380 / 155 / 380	1983 +1	6
	380 / 155 / 380 / 380 / 155 / 380	1825 +1	5
	155 / 590 / 155	886 +1	2
	155 / 590 / 155 / 380	1269 +1	3
	380 / 155 / 590 / 155 / 380	1652 +1	4
	380 / 155 / 804 / 155 / 380	1866	4

Recommended position for gas wok and grill

Cut-out dimensions for appliance combinations in the 400 series. Calculator for calculating the width of the cut-out.

Calculation of the width of the cut-out for a surface mounting

Example using a combination of VI 414, VI 422, VP 414 and 2 VL 414.

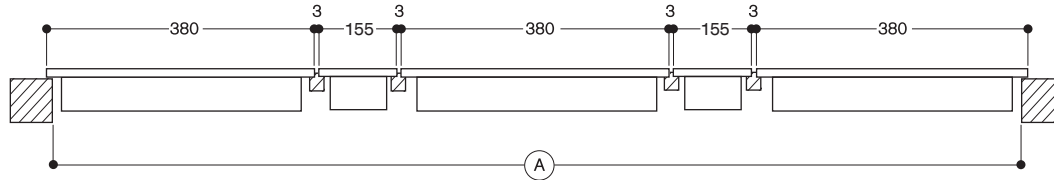

		Example		Your combination
Total width of all appliances	in mm	$(3 \times 380) + (2 \times 155)$	1.450
+ Number of connection strips	x 3 mm	4 x 3	+ 12
- Lateral appliance projection	(10 mm / side)	20	- 20	- 20
(A) Total width of the cut-out	(in mm)		1.442 +/- 1 +/- 1

Calculation of the width of the cut-out for a flush mounting

Example using a combination of VI 414, VI 422, VP 414 and 2 VL 414.

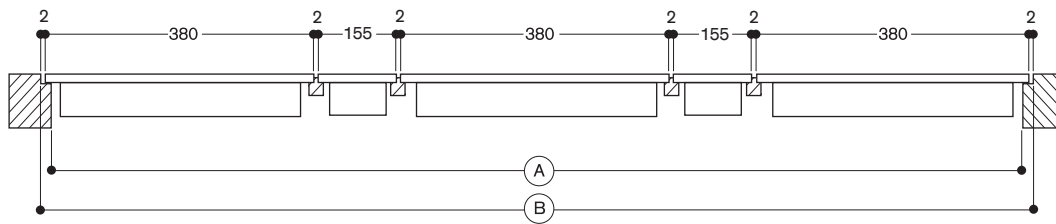

		Example		Your combination
Total width of all appliances	in mm	$(3 \times 380) + (2 \times 155)$	1.450
+ Number of connection strips	x 2 mm	4 x 2	+ 8
- Lateral appliance projection	(7 mm / side)	14	- 14	- 14
(A) Total width of the cut-out	(in mm)		1.444 +/- 1 +/- 1
+ Lateral appliance projection	(7 mm / side)	14	+ 14	+ 14
+ Silicone joint (2 mm circumference)		2 x 2	+ 4	+ 4
(B) Total width with groove	(in mm)		1.462 +/- 1 0/+ 1



VI 262 120

Black aluminium control panel
Width 60 cm

Included in the price

1 glass scraper

Installation accessories

VV 200 010

Stainless steel connection strip for combination with other Vario appliances of the 200 series

VV 200 020

Black connection strip for combination with other Vario appliances of the 200 series

Special accessories

CA 051 301

Teppan Yaki plate made of multi ply material
For flex induction cooktop.

CA 052 300

Griddle plate in cast aluminum
Non-stick.

For flex induction cooktop.

CA 050 300

Flex Pan set, 3 pcs.

Non-stick coating.

For flex induction cooktop.

CA 055 300

Flex Pan large

Non-stick coating.

For flex induction cooktop.

Vario flex induction cooktop 200 series

VI 262

- Can be combined with the cooktops of the Vario 200 series to a harmonic unity
- Control panel for comfortable and secure operation

Cooking zones

2 flex induction cooking areas 23x19 cm (2200 W, with booster 3700 W), linked together 23x38 cm (3300 W, with booster 3700 W).

2 flex induction cooking areas 23x19 cm (2200 W, with booster 3700 W), linked together 23x38 cm (3300 W, with booster 3700 W).

Handling

Control knobs with illuminated ring. Integrated control panel. Electronic power control in 9 output levels.

Features

Cooking area marking.

Flex function for rectangular cooking areas.

Frying sensor function.

Pot detection.

Booster function for each cooking area.

Safety

Residual heat indication.

Operation indicator.

Safety shut-off.

Planning notes

Operates with magnetic (induction) iron pots and pans only. For an optimal heat distribution, the use of sandwich bottom cookware is recommended.

Special accessories

(please order as spare parts):

Part No. 17006018

Frying sensor pan, ø 20 cm

Appliance can be snapped into the worktop from above.

Appliance weight: approx. 17 kg.

Please read the installation details regarding air ducting on page 210.

Please read additional planning notes on page 144 – 145.

Connection

Total connected load 7.4 kW.

Connecting cable 1.5 m without plug.

Installation of the cooktop; surface mounting

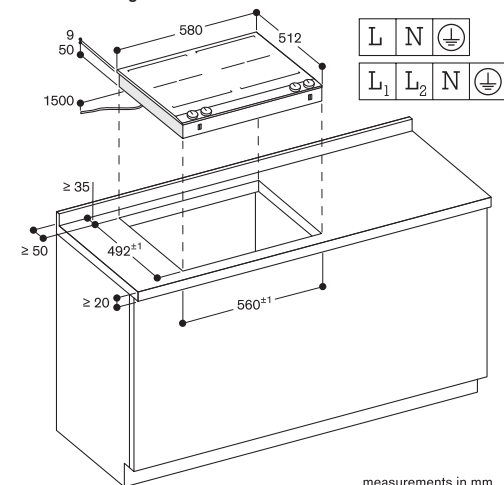

measurements in mm



VI 242 120

Black aluminium control panel
Width 38 cm

Included in the price

1 glass scraper

Installation accessories

VV 200 010

Stainless steel connection strip for combination with other Vario appliances of the 200 series

VV 200 020

Black connection strip for combination with other Vario appliances of the 200 series

Special accessories

CA 051 301

Teppan Yaki plate made of multi ply material
For flex induction cooktop.

CA 052 300

Griddle plate in cast aluminum
Non-stick.

For flex induction cooktop.

CA 050 300

Flex Pan set, 3 pcs.

Non-stick coating.

For flex induction cooktop.

CA 055 300

Flex Pan large

Non-stick coating.

For flex induction cooktop.

Vario flex induction cooktop 200 series

VI 242

- Can be combined with the cooktops of the Vario 200 series to a harmonic unity
- Control panel for comfortable and secure operation

Cooking zones

2 flex induction cooking areas 24x19 cm (2200 W, with booster 3700 W), linked together 24x38 cm (3300 W, with booster 3700 W).

Handling

Control knobs with illuminated ring. Integrated control panel. Electronic power control in 9 output levels.

Features

Cooking area marking.

Flex function for rectangular cooking areas.

Frying sensor function.

Pot detection.

Booster function for both cooking areas.

Safety

Residual heat indication.

Operation indicator.

Safety shut-off.

Planning notes

Operates with magnetic (induction) iron pots and pans only. For an optimal heat distribution, the use of sandwich bottom cookware is recommended.

Special accessories

(please order as spare parts):

Part No. 17006018

Frying sensor pan, ø 20 cm

Part No. 17006184

Frying sensor pan, ø 24 cm

Appliance can be snapped into the worktop from above.

Appliance weight: approx. 9 kg.

Please read the installation details regarding air ducting on page 210.

Please read additional planning notes on page 144 – 145.

Connection

Total connected load 3.7 kW.

Connecting cable 1.5 m without plug.

Installation of the cooktop; surface mounting

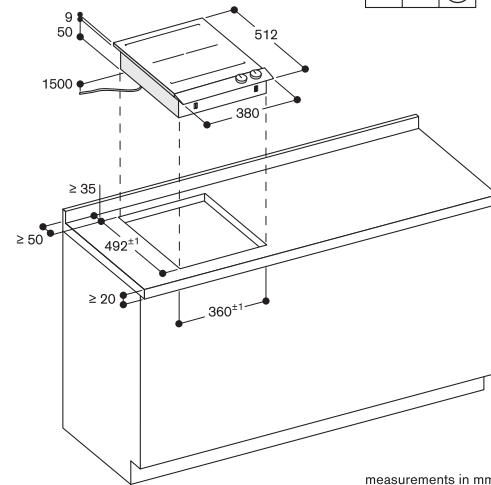

measurements in mm



VI 232 121
Black aluminium control panel
Width 28 cm

Included in the price
1 glass scraper

Installation accessories
VV 200 010
Stainless steel connection strip for combination with other Vario appliances of the 200 series
VV 200 020
Black connection strip for combination with other Vario appliances of the 200 series

Special accessories
CA 051 301
Teppan Yaki plate made of multi ply material
For flex induction cooktop.
CA 052 300
Griddle plate in cast aluminum
Non-stick.
For flex induction cooktop.
CA 050 300
Flex Pan set, 3 pcs.
Non-stick coating.
For flex induction cooktop.
CA 055 300
Flex Pan large
Non-stick coating.
For flex induction cooktop.
VD 200 020
Black appliance cover

Vario flex induction cooktop 200 series
VI 232

- Can be combined with the cooktops of the Vario 200 series to a harmonic unity
- Control panel for comfortable and secure operation

Cooking zones
2 flex induction cooking areas 21x19 cm (2200 W, with booster 3700 W), linked together 21x38 cm (3300 W, with booster 3700 W).

Handling
Control knobs with illuminated ring.
Integrated control panel.
Electronic power control in 9 output levels.

Features
Cooking area marking.
Flex function for rectangular cooking areas.
Frying sensor function.
Pot detection.
Booster function for both cooking areas.

Safety
Residual heat indication.
Operation indicator.
Safety shut-off.

Planning notes
Operates with magnetic (induction) iron pots and pans only. For an optimal heat distribution, the use of sandwich bottom cookware is recommended.

Special accessories
(please order as spare parts):
Part No. 17006018
Frying sensor pan, ø 20 cm

Appliance can be snapped into the worktop from above.
Appliance weight: approx. 9 kg.

Please read the installation details regarding air ducting on page 210.

Please read additional planning notes on page 144 – 145.

Connection
Total connected load 3.7 kW.
Connecting cable 1.5 m without plug.



Installation of the cooktop; surface mounting

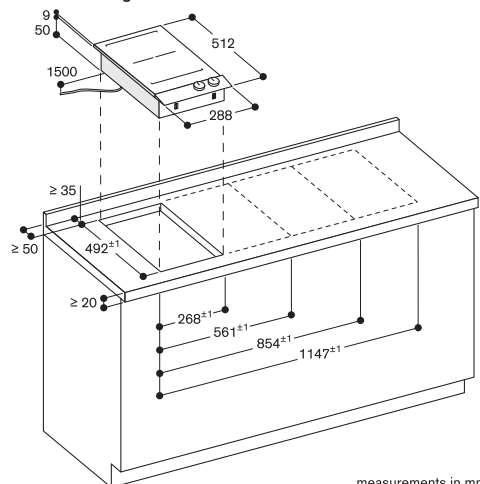



VG 264 120F

Black aluminium control panel
Width 60 cm
Liquid gas 28 – 37 mbar

VG 264 220

Black control panel
Width 60 cm
Natural gas 20 mbar

Installation accessories

VV 200 010

Stainless steel connection strip for combination with other Vario appliances of the 200 series

VV 200 020

Black connection strip for combination with other Vario appliances of the 200 series

Vario gas cooktop 200 series

VG 264

- Can be combined with the cooktops of the Vario 200 series to a harmonic unity
- Control panel for comfortable and secure operation
- Mechanical power level regulation for 9 power levels, with exact setting and reproduction of flame size
- Solid smooth-surface cast pan supports for easy and safe positioning of cookware
- Up to 9.8 KW on 4 burners

Cooking zones

2 high output burner (560 W - 3000 W), suitable for pots up to max. \varnothing 22 cm.
2 standard burners (380 W – 1900 W), suitable for pots up to max. \varnothing 20 cm.

Handling

Control knobs with illuminated ring.
Integrated control panel.
One-handed operation.
Electric ignition.

Features

Two-part cast iron pan support with continuous pot surface.
Enamelled burner cover.

Safety

Thermoelectric safety pilot.
Residual heat indication.
Operation indicator.

Planning notes

VG 264 120F

Special nozzles for natural gas 20 mbar can be ordered as spare parts.

VG 264 220

Special nozzles for liquid gas 28-30/37 mbar can be ordered as spare parts.

No intermediate shelf required.
Appliance can be snapped into the worktop from above.
A minimum lateral clearance of at least 150 mm from adjacent heat-sensitive furniture or contact surfaces must be observed or thermal insulation fitted.
With a total connected load of more than 11 kW local regulations concerning room ventilation, room size and combination of extraction or recirculation hoods must be observed.
The minimum distance between the cooktop surface and a cabinet above, out of combustible material, needs to be 65 cm.
The minimum distance to a ventilation above is shown at the planning hints for the individual ventilation product.
Appliance weight: approx. 15 kg.

Please read additional planning notes on page 144 – 145.

Connection

Total connected load gas 9.8/9.8 kW.
Total connected load electric 10.0/10.0 W.
Connecting cable 1.5 m with plug.

Installation of the cooktop; surface mounting

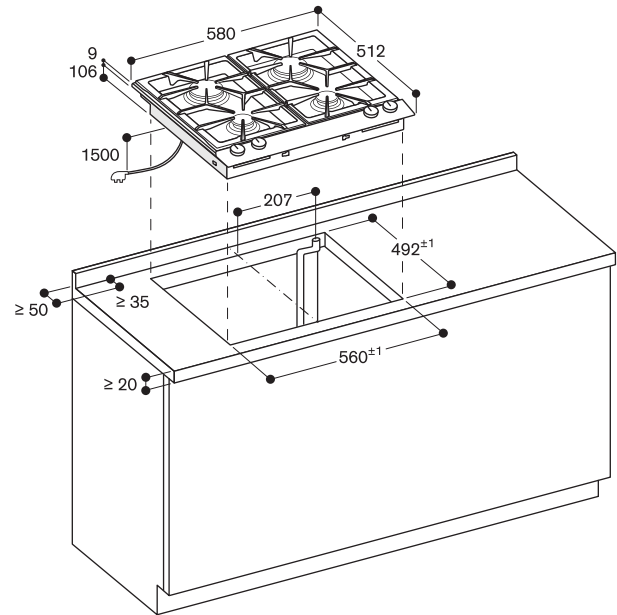

Minimum distance from the appliance cut-out to the side wall 150 mm.

measurements in mm

Gas connection

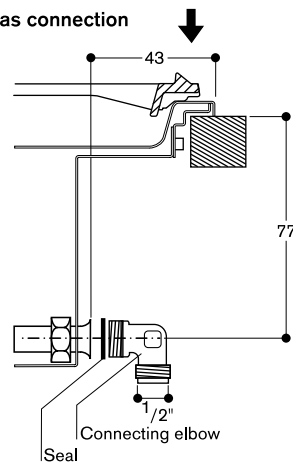



VG 231 120F
 Black aluminium control panel
 Width 28 cm
 Liquid gas 28 – 37 mbar
 Wok burner with up to 5.8 kW

VG 231 220
 Black control panel
 Width 28 cm
 Natural gas 20 mbar
 Wok burner with up to 6 kW

Included in the price
 1 wok attachment ring

Installation accessories
VV 200 010
 Stainless steel connection strip for combination with other Vario appliances of the 200 series

VV 200 020
 Black connection strip for combination with other Vario appliances of the 200 series

Special accessories
VD 200 020
 Black appliance cover

WP 400 001
 Wok pan made of multiple-layer material
 With round bottom and handle,
 ø36 cm, 6 litres, height 10 cm.

Vario gas wok 200 series
VG 231

- Can be combined with the cooktops of the Vario 200 series to a harmonic unity
- Control panel for comfortable and secure operation
- Mechanical power level regulation for 9 power levels, with exact setting and reproduction of flame size
- Multi-ring burner of solid, heat-resistant brass as used in professional kitchen
- Total output up to 6 kW

Cooking zones
VG 231 120F
 1 multi-ring wok burner (300 W – 5800 W), suitable for pots up to max. ø 30 cm.

VG 231 220
 1 multi-ring wok burner (300 W – 6000 W), suitable for pots up to max. ø 30 cm.

Handling
 Control knobs with illuminated ring.
 Integrated control panel.
 One-handed operation.
 Electric ignition.
 To close the cover, the cast iron pan support can be easily reversed.

Features
 Cast iron pan support.
 Brass burner rings.

Safety
 Thermoelectric safety pilot.
 Residual heat indication.
 Operation indicator.

Planning notes
VG 231 120F
 Special nozzles for natural gas 20 mbar can be ordered as spare parts.

VG 231 220
 Special nozzles for liquid gas 28-30/37 mbar can be ordered as spare parts.

Appliance can be snapped into the worktop from above.
 A minimum clearance of at least 150 mm from adjacent heat-sensitive furniture or contact surfaces must be observed or thermal insulation fitted.
 With a total connected load of more than 11 kW local regulations concerning room ventilation, room size and combination of extraction or recirculation hoods must be observed.
 The minimum distance between the cooktop surface and a cabinet above, out of combustible material, needs to be 65 cm.
 The minimum distance to a ventilation above is shown at the planning hints for the individual ventilation product.
 Appliance weight: approx. 11 kg.

Please read additional planning notes on page 144 – 145.

Connection
 Total connected load gas 5.8/6.0 kW.
 Total connected load electric 10.0/10.0 W.
 Connecting cable 1.5 m with plug.

Installation of the cooktop; surface mounting

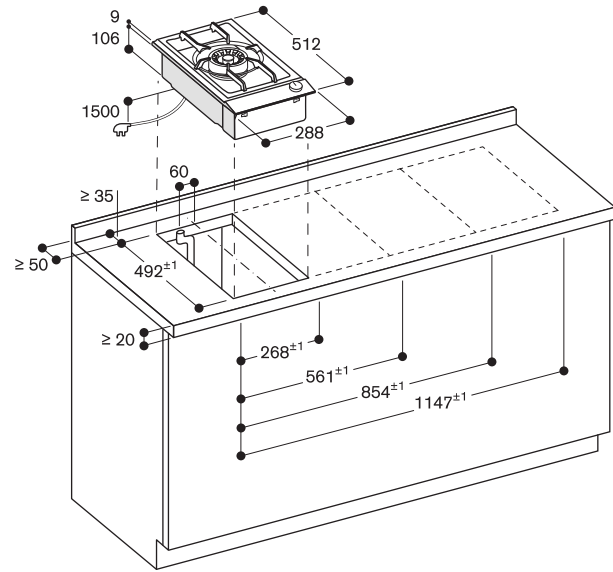

Minimum distance from the appliance cut-out to the side wall 150 mm.
 measurements in mm

Gas connection

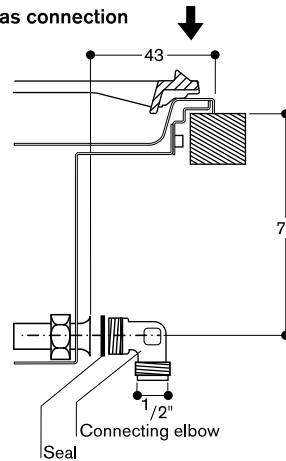



VG 232 120F

Black aluminium control panel
Width 28 cm
Liquid gas 28 – 37 mbar

VG 232 220

Black aluminium control panel
Width 28 cm
Natural gas 20 mbar

Installation accessories

VV 200 010

Stainless steel connection strip for combination with other Vario appliances of the 200 series

VV 200 020

Black connection strip for combination with other Vario appliances of the 200 series

Special accessories

VD 200 020

Black appliance cover

Vario gas cooktop 200 series

VG 232

- Can be combined with the cooktops of the Vario 200 series to a harmonic unity
- Control panel for comfortable and secure operation
- Mechanical power level regulation for 9 power levels, with exact setting and reproduction of flame size
- Solid smooth-surface cast pan supports for easy and safe positioning of cookware

Cooking zones

1 high output burner (560 W - 3000 W), suitable for pots up to max. \varnothing 22 cm.
1 standard burner (380 W - 1900 W), suitable for pots up to max. \varnothing 20 cm.

Handling

Control knobs with illuminated ring.
Integrated control panel.
One-handed operation.
Electric ignition.

Features

Cast pan support with continuous pot surface.
Enamelled burner cover.

Safety

Thermoelectric safety pilot.
Residual heat indication.
Operation indicator.

Planning notes

VG 232 120F
Special nozzles for natural gas 20 mbar can be ordered as spare parts.

VG 232 220

Special nozzles for liquid gas 28-30/37 mbar can be ordered as spare parts.

Appliance can be snapped into the worktop from above.
A minimum clearance of at least 150 mm from adjacent heat-sensitive furniture or contact surfaces must be observed or thermal insulation fitted.
With a total connected load of more than 11 kW local regulations concerning room ventilation, room size and combination of extraction or recirculation hoods must be observed.
The minimum distance between the cooktop surface and a cabinet above, out of combustible material, needs to be 65 cm.
The minimum distance to a ventilation above is shown at the planning hints for the individual ventilation product.
Appliance weight: approx. 9 kg.

Please read additional planning notes on page 144 – 145.

Connection

Total connected load gas 4.9/4.9 kW.
Total connected load electric 10.0/10.0 W.
Connecting cable 1.5 m with plug.

Installation of the cooktop; surface mounting

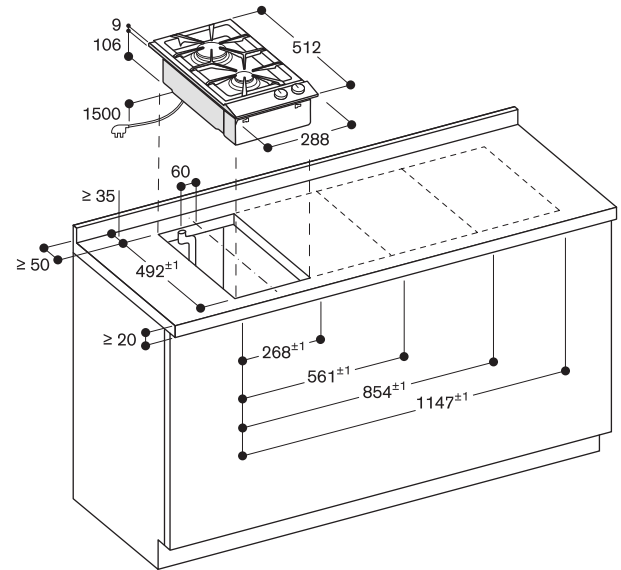

Minimum distance from the appliance cut-out to the side wall 150 mm.

measurements in mm

Gas connection

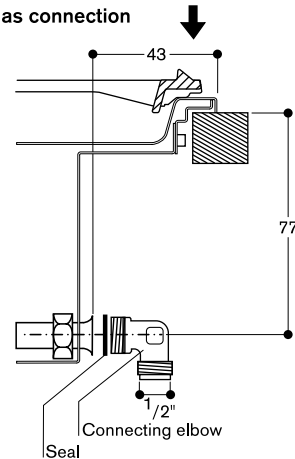



VP 230 120
Black aluminium control panel
Width 28 cm

Included in the price
2 spatula

Installation accessories
VV 200 010
Stainless steel connection strip for combination with other Vario appliances of the 200 series
VV 200 020
Black connection strip for combination with other Vario appliances of the 200 series

Special accessories
VD 200 020
Black appliance cover

Vario Teppan Yaki 200 series
VP 230

- Can be combined with the cooktops of the Vario 200 series to a harmonic unity
- Control panel for comfortable and secure operation
- Cooking directly on the metal surface, without any pots or pans
- Exact temperature control up to 240 °C
- Keeping warm setting

Cooking zones
Useable area: 844 cm².

Handling
Control knobs with illuminated ring.
Integrated control panel.
Electronic temperature control from 140 °C to 240 °C.

Features
Heating element with 1800 W.
Keeping warm setting.
Cleaning stage.
Stainless steel frame seamlessly welded with the stainless steel surface.

Safety
Pre-heat and residual heat indicator.
Operation indicator.
Safety shut-off.

Planning notes
The distance from the upper edge of the work surface to the upper edge of the intermediate shelf must be at least 150 mm.
Appliance can be snapped into the worktop from above.
A minimum lateral clearance of at least 30 mm from adjacent heat-sensitive furniture or contact surfaces must be observed or thermal insulation fitted.
Intermediate shelf required; after installation, this shelf must only be removed using tools to guarantee the touch protection from below.
Appliance weight: approx. 9 kg.

Please read additional planning notes on page 144 – 145.

Connection
Total connected load 1.8 kW.
Connecting cable 1.8 m without plug.



Installation of the cooktop; surface mounting

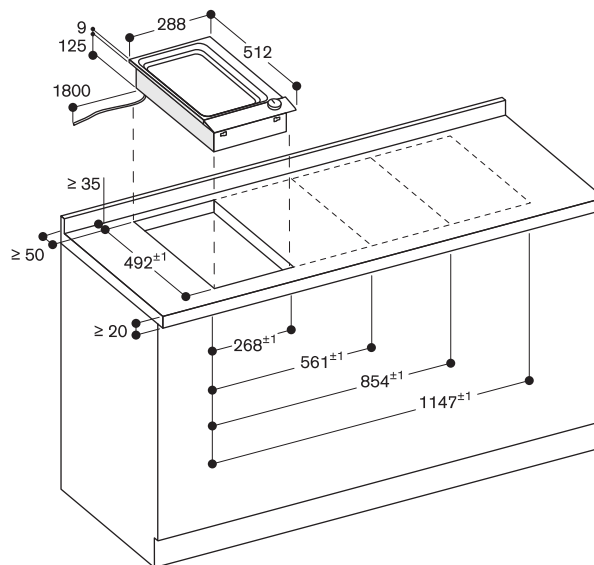

measurements in mm



VR 230 120

Black aluminium control panel
Width 28 cm

Included in the price

- 1 cast grill
- 1 lava stones
- 1 cleaning brush

Installation accessories

VV 200 010

Stainless steel connection strip for combination with other Vario appliances of the 200 series

VV 200 020

Black connection strip for combination with other Vario appliances of the 200 series

Special accessories

LV 030 000

Lava stones for refilling

VD 200 020

Black appliance cover

Vario electric grill 200 series

VR 230

- Can be combined with the cooktops of the Vario 200 series to a harmonic unity
- Control panel for comfortable and secure operation
- 2 zones, separately controlled
- Open cast grill, lava stone

Handling

Control knobs with illuminated ring.
Integrated control panel.
9 switching levels.

Features

2 separately controllable swing-out grilling elements (1500 W).
Join function.
Cast grill.
Stainless steel lavastone container and grease collecting insert, dishwasher-safe.

Safety

Pre-heat and residual heat indicator.
Operation indicator.
Safety shut-off.

Planning notes

Appliance can be snapped into the worktop from above.
A minimum clearance of at least 200 mm from adjacent heat-sensitive furniture or contact surfaces must be observed or thermal insulation fitted.
Appliance weight: approx. 17 kg.

Please read additional planning notes on page 144 – 145.

Connection

Total connected load 3.0 kW.
Connecting cable 1.8 m without plug.



Installation of the cooktop; surface mounting

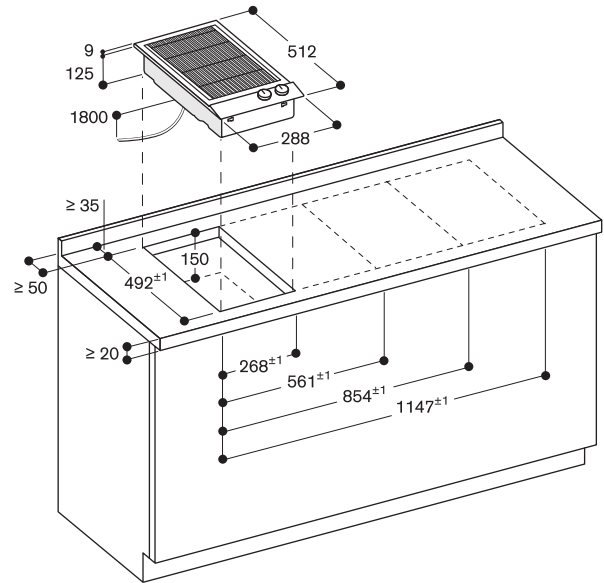

measurements in mm



VL 200 120
 Black aluminium control panel
 Width 15 cm
 Air extraction / Air recirculation
 Motorless



In combination with remote fan units
 AR 400 142
 AR 401 142
 AR 403 122
 AR 413 122
 AR 410 110

Installation accessories
AD 410 040
 Flexibel connecting piece for VL 200 DN 150 flat
AD 851 041
 Connecting piece VL 200 for extension with flat duct DN 150 for extra deep worktop
VV 200 010
 Stainless steel connection strip for combination with other Vario appliances of the 200 series
VV 200 020
 Black connection strip for combination with other appliances of the 200 series

Special accessories
LS 041 001
 Ventilation moulding for VL 200 next to gas appliance
 Stainless steel

Installation accessories for air ducting you will find at the pages 287 – 293.

Vario downdraft ventilation 200 series VL 200

- Can be combined with the cooktops of the Vario 200 series to a harmonic unity
- Highly efficient ventilation system at the cooktop integrated in the worktop
- Function for automatic, sensor-controlled power adjustment depending on the build-up of cooking vapours
- Minimal planning and easy installation
- Low-noise system with the motor AR 410 110
- Air extraction or air recirculation system

Output
 Power levels depend on the remote fan unit.
 Refer to the "Technical specifications" of the hood for the matching remote fan units for air recirculation or air extraction mode.

Features
 Control knobs with illuminated ring.
 3 electronically controlled power levels and 1 intensive mode.
 Automatic sensor-controlled performance adjustment of the ventilation system.
 Automatic sensor controlled or manual run on function.
 Large-scale metal grease filter with high grease absorption.
 Removable, dishwasher-safe grease filter unit.
 Grease filter and activated charcoal filter saturation indicator.
 Airflow-optimised interior for efficient air circulation.
 Interval ventilation, 6 min.
 Enamelled ventilation grille, dishwasher-safe.
 Air exhaust bend included in delivery.
 Overflow 250 ml capacity.

Consumption data
 Consumption data is referred to a configuration with the remote fan unit AR 403 122.
 Energy efficiency class A at a range of energy efficiency classes from A+++ to D.
 Energy consumption 48.3 kWh/year.
 Ventilation efficiency class A.
 Illumination efficiency class -.
 Grease filter efficiency class B.
 Sound level min. 56 dB / max. 71 dB normal mode.

Planning notes
 The equivalent ducting length to ensure good performance is Lmax 26 m.
 Air recirculation mode in combination with remote fan unit with AR 410 110 or AR 413 122.
 Air extraction in combination with remote fan unit AR 400 142, AR 401 142 or AR 403 122.
 For each VL one remote fan unit is recommended.
 Maximum cooktop width between 2 VL: 80 cm.
 Vario cooktops like Vario electric grill and Vario gas wok should be placed between 2 VL.
 In case of Vario electric grill recirculation is not recommended.

If installed next to gas appliances, the ventilation moulding LS 041 001 is recommended to ensure maximum performance of the cooktop.
 When having installed the ventilation moulding LS 041 001 the wok pan WP 400 001 can not be used.
 Air recirculation is not recommended in combination with Vario electric grill.
 When installing a ventilation hood with air extraction mode and a chimney-vented fireplace, the power supply line of the ventilation appliance needs a suitable safety switch.

Please read additional planning notes on page 262 – 265.

Connection
 Connecting cable 1.7 m between VL and remote fan unit.

Installation of the downdraft ventilation; surface mounting

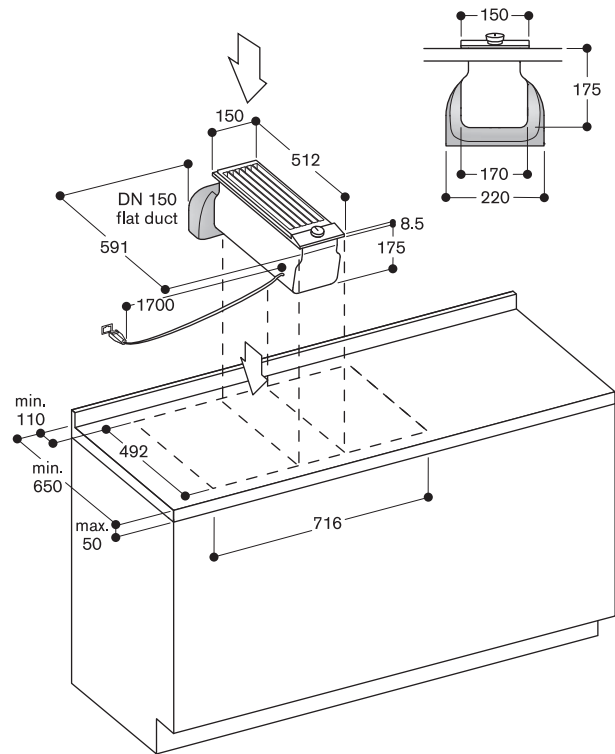

AD 410 040: Flexibel connecting piece for VL, DN 150 flat

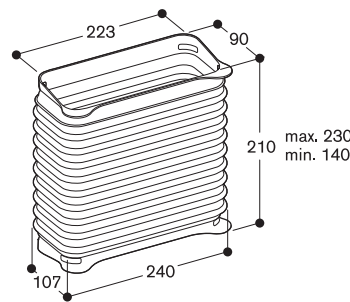

AD 851 041: Connecting piece VL for extension with flat duct DN 150 for extra deep worktop

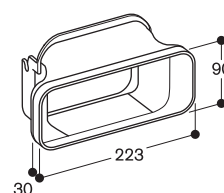



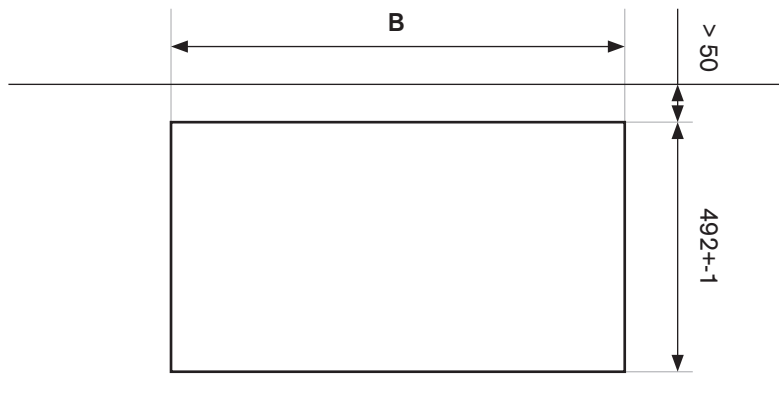

*Energy efficiency class: at a range of energy efficiency classes from A+++ to D.

Sample combinations without ventilation VL 200 element.

Cut-out dimensions for appliance combinations in the 200 series. The technician can find the suitable cut-out dimensions for the combinations most frequently used by referring to the previous pages and the drawings below.



Cooktops	Appliances size [mm]	Dimension B [mm]	# of VV200010 / VV200020
	288	561 +-1	1
	288	854 +-1	2
	288	1147 +-1	3
	380 / 288	653 +-1	1
	580	853 +-1	1

Cut-out dimensions for appliance combinations in the 200 series. The technician can find the suitable cut-out dimensions for the combinations most frequently used by referring to the previous pages and the drawings below.

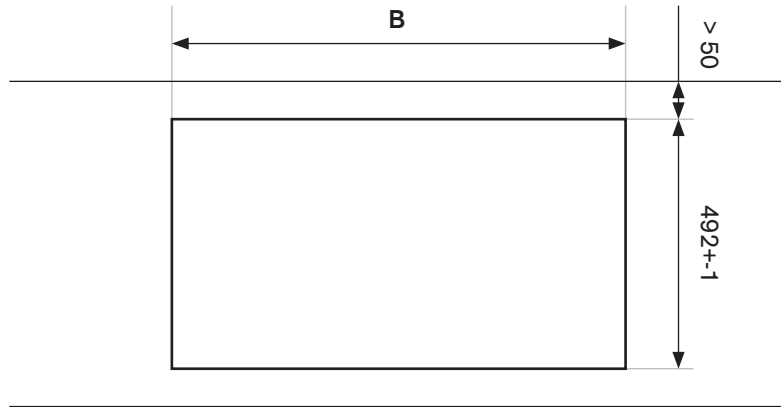

Cooktops	Appliances size [mm]	Dimension B [mm]	# of VV200010 / VV200020
	288 / 150	716 +-1	2
	380 / 150 / 380	900 +-1	3
	288 / 150 / 150	871 +-1	3
	288 / 150 / 150	1164 +-1	4
	288 / 150 / 150	1457 +-1	5
	380 / 150 / 288	808 +-1	3
	150 / 580 / 150	870 +-1	2
	288 / 150 / 580 / 150	1163 +-1	3

Recommended position for gas wok and grill

Accessories and special accessories for Vario cooktops 400 series

CA 414 110F
Socket



CA 414 100F
Black socket



CA 060 300
Cooking sensor for temperature regulation within pots.



LV 030 000
Lava stone for refilling



VA 440 010
Stainless steel appliance cover with mounting strip

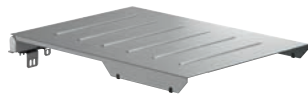

WP 400 001
Wok pan made of multiple-layer material
With round bottom and handle,
ø36 cm, 6 litres, height 10 cm.



WZ 400 000
Wok attachment for wok pan



AA 414 010
Ventilation moulding for VL 414 next to gas appliance



VA 420 004
Connection strip for combination with other Vario appliances of the 400 series for flush mounting



VA 420 010
Connection strip for combination with other Vario appliances of the 400 series for surface mounting



LV 030 000
Lava stone for refilling



VD 200 020
Black appliance cover



LS 041 001
Ventilation moulding for VL 200 next to gas appliance
Stainless steel

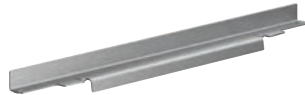

VV 200 010
Stainless steel connection strip for combination with other Vario appliances of the 200 series.



VV 200 020
Black connection strip for combination with other Vario appliances of the 200 series.



Vario induction cooktops 400 series



Appliance type	Full surface induction cooktop	Full surface induction cooktop
Frameless for flush mounting	-	-
Stainless steel frame 3 mm for surface or flush mounting	CX 492 111	CX 482 111
Dimensions		
Width (cm)	90	90
Depth (cm)	52	52
Immersion depth (cm)	6.5	6.5
Operation		
Knobs in furniture front / Knobs on integrated control panel	-/-	-/-
TFT touch display / Twist-Pad control / Sensor control	•/-/-	•/-/-
Bicoloured display (white/orange)	-	-
Respective knobs (Stainless steel / Black) ⁴	-	-
Cooking zones		
Number of cooking zones or items of cookware	6	6
Full surface induction cooktop	•	•
Flex induction cooking areas 23 x 19 cm (2200, with booster 3700 W) / linked together 23 x 38 cm (3300, with booster 3700 W)	-	-
Flex induction cooking areas 24 x 19 cm (2200, with booster 3700 W) / linked together 24 x 38 cm (3300, with booster 3700 W)	-	-
Automatic extension up to 30cm width (3300, with booster 3700 W)	-	-
Induction cooking zone ø 21 cm (2200, with booster 3700 W) / ø 26 cm (2600, with booster 3700 W) / ø 32 cm (3300, with booster 3700 W)	-	-
Features		
Number of output levels	17	17
Flex function for rectangular cooking areas	-	-
Cooking sensor function / Frying sensor function	•/-	•/-
Number of frying sensor functions	-	-
Professional cooking function	•	•
Booster function for pots / pans	•/•	•/•
Keep warm function	•	•
Cooking timer: Number of cooking zones	6	6
Short-term timer	•	•
Stopwatch	•	•
Residual heat indicator	•	•
Child lock / Safety shut-off / Display cleaning protection	•/•/•	•/•/•
Pause function	•	•
Options menu	•	•
Hood control	• ²	• ²
Home network integration for digital services (Home Connect) wireless via WiFi.	• ³	• ³
Accessories		
Teppan Yaki made of multi ply material, GN1/1 (for full surface induction)	GN 232 110 ¹	GN 232 110 ¹
Teppan Yaki made of multi ply material, GN2/3 (for full surface induction)	GN 232 230 ¹	GN 232 230 ¹
Teppan Yaki made of multi ply material (for flex induction)	-	-
Griddle plate in cast aluminium (for flex induction)	-	-
Flex Pan set, 3 pcs. (for flex induction)	-	-
Flex Pan large (for flex induction)	-	-
Frying sensor pan (available via customer service), ø20 cm	-	-
Frying sensor pan (available via customer service), ø24 cm	-	-
Frying sensor pan (available via customer service), ø28 cm	-	-
Frying sensor pan (available via customer service), ø32 cm	-	-
Cooking sensor	• / CA 060 300 ¹	• / CA 060 300 ¹
Wok attachment for for wok pan	-	-
Wok pan	-	-
Connection		
Total connected load electric (kW)	7.4	7.4

• Standard. – Not available.

¹ Special accessories.

² In combination with suitable hood.

³ The use of the Home Connect functionality depends on the Home Connect services, which are not available in every country.

⁴ Knobs need to be ordered separately.



Induction cooktop	Induction cooktop	Induction cooktop	Induction cooktop	Induction cooktop
VI 492 105	VI 482 105	VI 462 105	VI 422 105	VI 414 105
VI 492 115	VI 482 115	VI 462 115	VI 422 115	VI 414 115
90	80	60	38	38
52	52	52	52	52
5.7	5.7	5.7	5.7	5.7
•/-	•/-	•/-	•/-	•/-
-/-/•	-/-/•	-/-/•	-/-/•	-/-/•
•	•	•	•	•
CKI 450 010 / CKI 450 000	CKI 440 010 / CKI 440 000	CKI 440 010 / CKI 440 000	CKI 420 010 / CKI 420 000	CKI 410 010 / CKI 410 000
5	4	4	2	1
-	-	-	-	-
4	4	4	-	-
-	-	-	2	-
-	2	1	-	-
1	-	-	-	1
12	12	12	12	12
•	•	•	•	•
-/•	-/•	-/•	-/•	-/•
5	4	4	2	1
-	-	-	-	-
•/-	•/-	•/-	•/-	•/-
-	-	-	-	-
-	-	-	-	-
•	•	•	•	•
•	•	•	•	•
•	•	•	•	•
-/•/-	-/•/-	-/•/-	-/•/-	-/•/-
-	-	-	-	-
•	•	•	•	•
• ²	• ²	• ²	• ²	• ²
• ³	• ³	• ³	• ³	• ³
-	-	-	-	-
-	-	-	-	-
CA 051 301 ¹	CA 051 301 ¹	CA 051 301 ¹	CA 051 301 ¹	-
CA 052 300 ¹	CA 052 300 ¹	CA 052 300 ¹	CA 052 300 ¹	-
CA 050 300 ¹	CA 050 300 ¹	CA 050 300 ¹	CA 050 300 ¹	CA 050 300 ¹
CA 055 300 ¹	CA 055 300 ¹	CA 055 300 ¹	CA 055 300 ¹	CA 055 300 ¹
17006018 ¹	17006018 ¹	17006018 ¹	17006018 ¹	17006018 ¹
17006184 ¹	17006184 ¹	17006184 ¹	17006184 ¹	17006184 ¹
17006185 ¹	17006185 ¹	17006185 ¹	-	17006185 ¹
17006019 ¹	-	-	-	17006019 ¹
-	-	-	-	-
WZ 400 000 ¹	-	-	-	WZ 400 000 ¹
WP 400 001 ¹	-	-	-	WP 400 001 ¹
11.1	7.4	7.4	3.7	3.7

Vario induction cooktops 200 series



Appliance type		Flex induction cooktop	Flex induction cooktop	Flex induction cooktop
		VI 262 120	VI 242 120	VI 232 121
Surface mounting / Flush mounting		•/-	•/-	•/-
Dimensions				
Width	(cm)	60	38	28
Depth	(cm)	51.2	51.2	51.2
Immersion depth	(cm)	5	5	5
Operation				
Knobs in furniture front / Knobs on integrated control panel		-/•	-/•	-/•
TFT touch display / Twist-Pad control / Sensor control		-/-/-	-/-/-	-/-/-
Bicoloured display (white/orange)		-	-	-
Cooking zones / combinations				
Number of cooking zones or items of cookware		4	2	2
Full surface induction cooktop		-	-	-
Flex induction cooking areas 21 x 19 cm (2200, with booster 3700 W) / linked together 21 x 38 cm (3300, with booster 3700 W)		-	-	2
Flex induction cooking areas 23 x 19 cm (2200, with booster 3700 W) / linked together 23 x 38 cm (3300, with booster 3700 W)		4	-	-
Flex induction cooking areas 24 x 19 cm (2200, with booster 3700 W) / linked together 24 x 38 cm (3300, with booster 3700 W)		-	2	-
Features				
Number of output levels		9	9	9
Flex function for rectangular cooking areas		•	•	•
Cooking sensor function / Frying sensor function		-/•	-/•	-/•
Number of frying sensor functions		4	2	2
Professional cooking function		-	-	-
Booster function for pots / pans		•/-	•/-	•/-
Keep warm function		-	-	-
Cooking timer: Number of cooking zones		-	-	-
Short-term timer		-	-	-
Stopwatch		-	-	-
Residual heat indicator		•	•	•
Child lock / Safety shut-off / Display cleaning protection		-/•/-	-/•/-	-/•/-
Pause function		-	-	-
Options menu		-	-	-
Hood control		-	-	-
Home network integration for digital services (Home Connect) wireless via WiFi.		-	-	-
Accessories				
Teppan Yaki made of multi ply material (for flex induction)		CA 051 301 ¹	CA 051 301 ¹	CA 051 301 ¹
Griddle plate in cast aluminium (for flex induction)		CA 052 300 ¹	CA 052 300 ¹	CA 052 300 ¹
Flex Pan set, 3 pcs. (for flex induction)		CA 050 300 ¹	CA 050 300 ¹	CA 050 300 ¹
Flex Pan large (for flex induction)		CA 055 300 ¹	CA 055 300 ¹	CA 055 300 ¹
Frying sensor pan (available via customer service), ø20 cm		17006018 ¹	17006018 ¹	17006018 ¹
Frying sensor pan (available via customer service), ø24 cm		-	17006184 ¹	-
Cooking sensor		-	-	-
Appliance cover (Stainless steel / Black)		-/-	-/-	- / VD 200 020 ¹
Connection				
Total connected load electric	(kW)	7.4	3.7	3.7

• Standard. - Not available.

¹ Special accessory.

Vario gas cooktops 400 series



Appliance type	Gas cooktop	Gas cooktop
	VG 491 115F	VG 491 215
Stainless steel frame 3 mm / Stainless steel brushed / shot blasted	•/-/-	•/-/-
Surface-mounted / flush installation / welded	•/•/-	•/•/-
Liquid gas 28-37 mbar / natural gas 20 mbar	•/-	-/•
Dimensions		
Width	(cm) 90	90
Depth	(cm) 52.0	52.0
Immersion depth	(cm) 14.1	14.1
Operation		
Knobs in furniture front / Knobs on integrated control panel	•/-	•/-
Respective knobs (Stainless steel / Black) ²	CKG 450 010 / CKG 450 000	CKG 450 010 / CKG 450 000
Cooking zones		
Number of cooking zones or items of cookware	5	5
Multi-ring wok burner (300 – 5800 W)	1	-
Multi-ring wok burner (300 – 6000 W)	-	1
Two-ring high output burner (165 – 4000 W)	2	2
Two-ring standard output burner (165 – 2000 W)	2	2
Features		
Number of output levels	12	12
Electronic output control	•	•
Automatic fast ignition / Electric ignition	•/-	•/-
Electronic flame monitoring with automatic re-ignition	•	•
Simmer function	•	•
Residual heat indicator	•	•
Safety shut-off	•	•
Cast pan support	3-part	3-part
Accessories		
Wok attachment ring	•	•
Wok pan	WP 400 001 ¹	WP 400 001 ¹
Appliance cover (Stainless steel / Black)	-/-	-/-
Connection		
Total connected load gas (up to)	(kW) 17.8	18.0
Total connected load electric	(W) 15.0	15.0

• Standard. – Not available.

¹ Special accessory.

² Knobs need to be ordered separately.



Gas wok	Gas wok	Gas cooktop	Gas cooktop
VG 415 115F	VG 415 215	VG 425 115	VG 425 215
•/-/-	•/-/-	•/-/-	•/-/-
•/•/-	•/•/-	•/•/-	•/•/-
•/-	-/•	•/-	-/•
38	38	38	38
52.0	52.0	52.0	52.0
13.4	13.4	13.4	13.4
•/-	•/-	•/-	•/-
CKG 410 010 / CKG 410 000	CKG 410 010 / CKG 410 000	CKG 420 010 / CKG 420 000	CKG 420 010 / CKG 420 000
1	1	2	2
1	-	-	-
-	1	-	-
-	-	1	1
-	-	1	1
12	12	12	12
•	•	•	•
•/-	•/-	•/-	•/-
•	•	•	•
•	•	•	•
•	•	•	•
•	•	•	•
1-part	1-part	1-part	1-part
•	•	-	-
WP 400 001 ¹	WP 400 001 ¹	-	-
VA 440 010 ¹ / -	VA 440 010 ¹ / -	VA 440 010 ¹ / -	VA 440 010 ¹ / -
5.8	6.0	6.0	6.0
15.0	15.0	15.0	15.0

Vario gas cooktops 200 series



Appliance type	Gas cooktop	Gas cooktop	Gas wok	Gas wok	Gas cooktop	Gas cooktop
	VG 264 120F	VG 264 220	VG 231 120F	VG 231 220	VG 232 120F	VG 232 220
Stainless steel frame / Stainless steel brushed / shot blasted	-/-•	-/-•	-/-•	-/-•	-/-•	-/-•
Surface-mounted / flush installation / welded	•/-/-	•/-/-	•/-/-	•/-/-	•/-/-	•/-/-
Liquid gas 28-37 mbar / Natural gas 20 mbar	• ² /-	-/• ³	• ² /-	-/• ³	• ² /-	-/• ³
Dimensions						
Width	(cm) 60	60	28	28	28	28
Depth	(cm) 51.2	51.2	51.2	51.2	51.2	51.2
Immersion depth	(cm) 10.6	10.6	10.6	10.6	10.6	10.6
Operation						
Knobs in furniture front / Knobs on integrated control panel	-/•	-/•	-/•	-/•	-/•	-/•
Cooking zones						
Number of cooking zones or items of cookware	4	4	1	1	2	2
Multi-ring wok burner (300 – 5800 W)	-	-	1	-	-	-
Multi-ring wok burner (300 – 6000 W)	-	-	-	1	-	-
Two-ring high output burner (165 – 4000 W)	2	2	-	-	1	1
Two-ring standard output burner (165 – 2000 W)	2	2	-	-	1	1
Features						
Number of output levels	9	9	9	9	9	9
Electronic output control	-	-	-	-	-	-
Automatic fast ignition / Electric ignition	-/•	-/•	-/•	-/•	-/•	-/•
Electronic flame monitoring with automatic re-ignition	-	-	-	-	-	-
Simmer function	-	-	-	-	-	-
Residual heat indicator	•	•	•	•	•	•
Safety shut-off	-	-	-	-	-	-
Cast pan support	2-part	2-part	1-part	1-part	1-part	1-part
Accessories						
Wok attachment ring	-	-	•	•	-	-
Wok pan	-	-	WP 400 001 ¹	WP 400 001 ¹	-	-
Appliance cover (Stainless steel / Black)	- / -	- / -	- / VD 200 020 ¹	- / VD 200 020 ¹	- / VD 200 020 ¹	- / VD 200 020 ¹
Connection						
Total connected load gas (up to)	(kW) 9.8	9.8	5.8	6.0	4.9	4.9
Total connected load electric	(W) 4.0	4.0	1.0	1.0	2.0	2.0

• Standard. – Not available.

¹ Special accessory.

² Nozzles for natural gas 20 mbar can be ordered as spare parts.

³ Nozzles for liquid gas 28-30/37 mbar can be ordered as spare parts.

⁴ Nozzles for liquid gas 50 mbar can be ordered as spare parts.



Appliance type	Teppan Yaki	Electric grill	Teppan Yaki	Electric grill
	VP 414 115	VR 414 115	VP 230 120	VR 230 120
Stainless steel frame 3 mm / Stainless steel brushed / shot blasted	•/-/-	•/-/-	-/-/•	-/-/•
Surface mounting / Flush mounting	•/•	•/•	•/-	•/-
Dimensions				
Width	(cm) 38	38	28	28
Depth	(cm) 52	52	51.2	51.2
Immersion depth	(cm) 11.8	11.8	12.5	12.5
Operation				
Knobs in furniture front / Knobs on integrated control panel	•/-	•/-	-/•	-/•
Respective knobs (Stainless steel / Black) ²	CKP 420 010 / CKP 420 000	CKR 420 010 / CKR 420 000	-	-
Cooking zones				
Number of cooking zones	2	2	1	2
Output	(kW) 2 x 1.5	2 x 1.5	1.8	2 x 1.5
Temperature range	(°C) 120 – 240	-	140 – 240	-
Features				
Number of output levels	12	12	10	9
Electronic temperature control	•	•	•	-
Two zones can be operated together / separately	•/•	•/•	-/•	-/•
Cast grill	-	2	-	1
Stainless steel container with lava stones	-	•	-	•
Grease collecting insert	-	•	-	•
Hard-chromed cooking surface	•	-	-	-
Stainless steel sandwich cooking surface	-	-	•	-
Keep warm function	•	-	•	-
Residual heat indicator	•	•	•	•
Child lock / Safety shut-off	-/•	-/•	-/•	-/•
Cleaning stage	•	-	-	-
Accessories				
Cast pan, half size	-	•	-	-
Appliance cover (Stainless steel / Black)	VA 440 010 ¹ / -	VA 440 010 ¹ / -	- / VD 200 020 ¹	- / VD 200 020 ¹
Cleaning brush	-	•	-	•
Spatula	2	-	2	-
Connection				
Total connected load	(kW) 3.0	3.0	1.8	3.0







• Standard. -Not available.
¹ Special accessory.
² The knobs must be ordered separately.





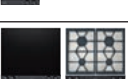









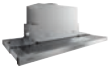

The cooktops

Gas cooktops	160
Integrated Induction cooktops	166
Induction cooktops	172
Flex induction cooktop with integrated ventilation system 400 series	180
Flex induction cooktop with integrated ventilation system 200 series	184
Flex induction cooktops	190
Planning notes for induction cooktops	210
Glass ceramic cooktops	211
Accessories special accessories	214
Technical specifications	216

Recommended Cooktop Ventilation Combinations

✓ : aesthetically and technically recommended combination — : not recommended 📶 : cooktop based ventilation control possible.								
Product type	Picture	VIB		AC 400 width depends on configuration	AC 250 121 width 120 cm	AW 442 width 120 cm	AW 240 191 width 90 cm	AI 240 191 width 90 cm
	Maximum width for cooktops combinations For integrated induction see dedicated pages.				100 cm 130 cm with fume collector	100 cm	80 cm	80 cm
Vario Teppan Yaki 400 serie Vario gas cooktop 400 series Vario electric grill 400 series		VP 414 / VG4.. / VR 414	40 cm	✓	✓	✓	—	—
Vario induction cooktop 400 series		VI4..	40 cm	✓	✓ 📶	✓	—	—
Vario induction cooktop 400 series		VI 462	60 cm	✓	✓ 📶	✓	—	—
Vario induction cooktop 400 series		VI 482	80 cm	✓	✓ 📶	✓	—	—
Vario induction cooktop 400 series		VI 492	90 cm	✓	✓ 📶	✓	—	—
Vario gas cooktop 400 series Gas cooktop 400 series		VG 491 / CG 492	90 cm	✓	✓	✓	—	—
Vario Teppan Yaki 200 series Vario flex induction cooktop 200 series Vario gas cooktop 200 series Vario electric grill 200 series		VP2.. / VI2.. / VR2.. / VG2.. / VR 230	30 cm	✓	✓	✓	—	—
Vario flex induction cooktop 200 series		VI 242	40 cm	✓	✓	✓	—	—
Vario flex induction cooktop 200 series Vario gas cooktop 200 series		VI 262 / VG 264	60 cm	✓	✓	✓	—	—
Integrated induction modules 400 series		CU 42..	21 cm 28 cm	✓	✓	—	—	—
Full surface induction cooktop 400 series with frame		CX 482 111	80 cm	✓	✓ 📶	✓	✓ 📶	—
Full surface induction cooktop 400 series frameless		CX 482 101	80 cm	✓	✓ 📶	✓	✓ 📶	—
Full surface induction cooktop 400 series		CX 492	90 cm	✓	✓ 📶	✓	—	—
Flex induction cooktop 200 series		CI 261	60 cm	✓	✓	✓	✓	✓
Flex induction cooktop 200 series		CI 262	60 cm	✓	✓ 📶	✓	✓ 📶	✓ 📶
Flex induction cooktop 200 series		CI 272	70 cm	✓	✓ 📶	✓	✓ 📶	✓ 📶
Flex induction cooktop 200 series		CI 282 / CI 283	80 cm	✓	✓ 📶	✓	✓ 📶	—
Flex induction cooktop 200 series		CI 292	90 cm	✓	✓ 📶	✓	—	—
Gas cooktop 200 series		CG 261	60 cm	✓	✓	✓	—	—
Gas cooktop 200 series		CG 291	90 cm	✓	✓	✓	—	—
Gas cooktop 200 series		VG 295	90 cm	✓	✓	✓	—	—
Glass ceramic cooktop 200 series		CE 261	60 cm	✓	✓	✓	✓	✓
Glass ceramic cooktop 200 series		CE 291	90 cm	✓	✓	✓	—	—

										
AL 400 122 width 120 cm	AL 400 192 width 90 cm	AL 200 180 width 80 cm	AL 200 190 width 90 cm	VL 414 width 15,5 cm	VL 200 width 15 cm	AF 210 192 width 90 cm	AF 210 162 width 60 cm	AC 200 191 width 86 cm	AC 200 181 width 70 cm	AC 200 161 width 52 cm
120 cm	90 cm					90 cm	60 cm	90 cm	70 cm	60 cm
✓	✓	-	-	✓	-	✓	✓	✓	✓	✓
✓	✓	-	-	✓ 	-	✓	✓	✓	✓	✓
-	-	-	-	✓	-	✓	✓	✓	✓	✓
✓	-	✓ 	-	✓	-	✓	-	✓	-	-
-	✓	-	✓ 	-	-	✓	-	✓	-	-
-	✓	-	-	-	-	✓	-	✓	-	-
-	-	-	-	-	✓	✓	✓	✓	✓	✓
-	-	-	-	-	✓	✓	✓	✓	✓	✓
-	-	-	-	-	✓	✓	✓	✓	✓	✓
-	-	-	-	-	-	-	-	-	-	-
✓	-	✓ 	-	-	-	✓	-	✓	-	-
-	-	✓ 	-	-	-	✓	-	✓	-	-
-	✓	-	✓ 	-	-	✓	-	✓	-	-
-	-	-	-	-	-	✓	✓	✓	✓	✓
-	-	-	-	-	-	✓	✓	✓	✓	✓
-	-	-	-	-	-	✓	✓	✓	✓	✓
-	-	-	-	-	-	✓	-	✓	✓	-
-	-	✓ 	-	-	-	✓	-	✓	-	-
-	✓	-	✓ 	-	-	✓	-	✓	-	-
-	-	-	-	-	-	✓	✓	✓	✓	✓
-	-	-	-	-	-	✓	-	✓	✓	-
-	-	-	-	-	-	✓	✓	✓	✓	✓
-	-	-	-	-	-	✓	-	✓	✓	-
✓	✓	-	-	-	-	✓	✓	✓	✓	✓
✓	✓	-	-	-	-	✓	-	✓	-	-



CG 492 111F

Stainless steel
Width 100.2 cm
Liquid gas 28 – 37 mbar
Wok burner with up to 5.8 kW

CG 492 211

Stainless steel
Width 100.2 cm
Natural gas 20 mbar
Wok burner with up to 6 kW

Included in the price

1 wok attachment ring

Necessary installation accessories

CA 429 410

Frame set including decorative frame (to be welded in stainless steel worktop) and holding frame

Special accessories

WP 400 001

Wok pan made of multiple-layer material
With round bottom and handle, ø36 cm, 6 litres, height 10 cm.

Gas cooktop 400 series

CG 492

- Five multi-ring burners, up to 18 kW
- Full electronic power level regulation on 12 levels
- Precise and reproducible flame size
- Automatic fast ignition, electronic flame monitoring with automatic re-ignition
- Simmer function for cooking on a very low output level
- Solid smooth-surface cast iron pan supports on the same level as the worktop
- Solid stainless steel control knob

Cooking zones

CG 492 111F

1 multi-ring wok burner (300 W – 5800 W), suitable for pots up to max. ø 32 cm.
2 two-ring high output burners (165 W – 4000 W), suitable for pots up to max. ø 28 cm.
2 two-ring standard burners (165 W – 2000 W), suitable for pots up to max. ø 24 cm.

CG 492 211

1 multi-ring wok burner (300 W – 6000 W), suitable for pots up to max. ø 32 cm.
2 two-ring high output burners (165 W – 4000 W), suitable for pots up to max. ø 28 cm.
2 two-ring standard burners (165 W – 2000 W), suitable for pots up to max. ø 24 cm.

Handling

Control knobs with illuminated ring, cooking zone and output level markings.
One-handed operation.
Full electronic control in 12 output levels for exact power level regulation plus simmer function.
Automatic fast ignition.

Features

Simmer function.
Three-part cast iron pan support with flat, continuous pot surface, on the same level as the worktop.
Brass burner rings.

Safety

Electronic flame monitoring with automatic re-ignition.
Residual heat indication.
Safety shut-off.

Planning notes

The frame set (necessary installation accessory) can be sent in advance to the manufacturer of the stainless steel or granite worktop for fitting.
Special nozzles can be ordered as spare parts.
Plan for an electrical connection (the appliance is not operable without power supply).
The horizontal positioning of the knobs may be aligned with the specific burners.
The drawing "Installation of the control knob" must be observed if the panel is more than 23 mm thick (there must be a recess at the rear).
Minimum worktop depth 70 cm.
Air intake from above.
No intermediate shelf required.

Due to the separate frame welded into the worktop, all parts remain fully accessible.

Rear panel and wall trims must be heat-resistant and consist of a non-flammable material.

The appliance can be fixed from above. A minimum lateral clearance of at least 300 mm from adjacent heat-sensitive furniture or contact surfaces must be observed or thermal insulation fitted. With a total connected load of more than 11 kW local regulations concerning room ventilation, room size and combination of extraction or recirculation hoods must be observed. The minimum distance between the cooktop surface and a cabinet above, out of combustible material, needs to be 76 cm.

The minimum distance to a ventilation above is shown at the planning hints for the individual ventilation product. The combination with VL 414 is not recommended, since the air extraction from the centre burner cannot be guaranteed due to the distance.
Appliance weight: approx. 35 kg.

Connection

Total connected load gas
17.8/18.0 kW.
Total connected load electric
15.0/15.0 W.
Connecting cable 1.4 m with plug.



VG 295 150F

Width 90 cm

Liquid gas 28 – 37 mbar

Wok burner with up to 5.8 kW

VG 295 250

Width 90 cm

Natural gas 20 mbar

Wok burner with up to 6 kW

Included in the price

1 wok attachment ring

Special accessories

WP 400 001

Wok pan made of multiple-layer material

With round bottom and handle, ø 36 cm, 6 litres, height 10 cm.

Gas cooktop 200 series

VG 295

- Control panel for comfortable and secure operation
- Mechanical power level regulation for 9 power levels, with exact setting and reproduction of flame size
- Multi-ring burner of solid, heat-resistant brass as used in professional kitchen
- Solid smooth-surface cast iron pan supports
- Up to 17.8 kW on 5 burners

Cooking zones

VG 295 150F

- 1 multi-ring wok burner (300 W – 5800 W), suitable for pots up to max. ø 32 cm.
- 2 two-ring high output burners (170 W – 4000 W), suitable for pots up to max. ø 28 cm.
- 2 two-ring standard burners (170 W – 2000 W), suitable for pots up to max. ø 24 cm.

VG 295 250

- 1 multi-ring wok burner (300 W – 6000 W), suitable for pots up to max. ø 32 cm.
- 2 two-ring high output burners (170 W – 4000 W), suitable for pots up to max. ø 28 cm.
- 2 two-ring standard burners (170 W – 2000 W), suitable for pots up to max. ø 24 cm.

Handling

Control knobs with illuminated ring.
Integrated control panel.
One-handed operation.
Electric ignition.

Features

Three-part cast iron pan support with flat, continuous pot surface.
Brass burner rings.

Safety

Thermoelectric safety pilot.
Residual heat indication.
Operation indicator.

Planning notes

VG 295 150F

Special nozzles for natural gas 20 mbar can be ordered as spare parts.

VG 295 250

Special nozzles for liquid gas 28-30/37 mbar can be ordered as spare parts.

No intermediate shelf required.
Appliance can be snapped into the worktop from above.
Rear panel and wall trims must be heat-resistant and consist of a non-flammable material.
Installation in a 90 cm wide lower cabinet is required.
A minimum lateral clearance of at least 300 mm from adjacent heat-sensitive furniture or contact surfaces must be observed or thermal insulation fitted.
With a total connected load of more than 11 kW local regulations concerning room ventilation, room size and combination of extraction or recirculation hoods must be observed.

The minimum distance between the cooktop surface and a cabinet above, out of combustible material, needs to be 76 cm.

The minimum distance to a ventilation above is shown at the planning hints for the individual ventilation product.

Appliance weight: approx. 29 kg.

Connection

Total connected load gas

17.8/18.0 kW.

Total connected load electric 10 W.

Connecting cable 1.5 m with plug.

Installation of the cooktop; surface mounting

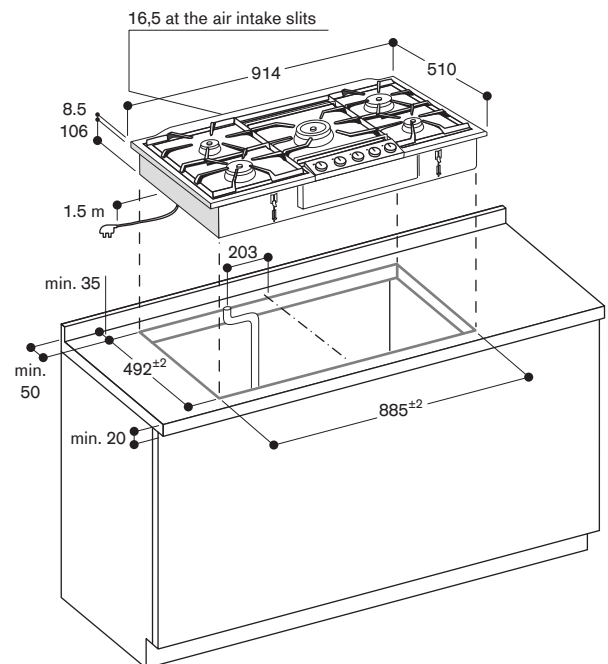

Minimum distance from the appliance cut-out to the side wall 300 mm.

Gas connection

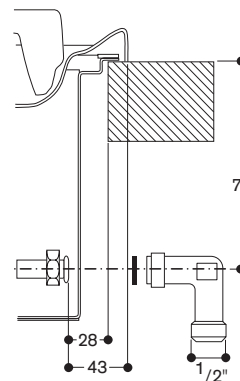

**CG 291 210**

Stainless steel
Width 90 cm
Natural gas 20 mbar
Nozzles for liquid gas 28-30/37 mbar included

Included in the price

1 cross support for espresso
1 wok attachment ring

Special accessories**WP 400 001**

Wok pan made of multiple-layer material
With round bottom and handle, ø36 cm, 6 litres, height 10 cm.

Gas cooktop 200 series**CG 291**

- Mechanical power level regulation for 9 power levels, with exact setting and reproduction of flame size
- Multi-ring burner with up to 5 kW

Cooking zones

1 multi-ring wok burner (300 W – 5000 W).
1 high output burner (500 W - 3000 W), suitable for pots up to max. ø 26 cm.
2 standard burners (350 W – 1750 W), suitable for pots up to max. ø 20 cm.
1 economy burner (330 W – 1000 W), suitable for pots up to max. ø 14 cm.

Handling

Control knobs with cooking zone and output level markings for 9 levels.
One-handed operation.
Electric ignition.

Features

Three-part cast iron pan support with continuous pot surface.
Enamelled burner cover.

Safety

Thermoelectric safety pilot.

Planning notes

The cooktop can only be surface-mounted.
Special nozzles can be ordered as spare parts.
Installation in a 85 cm niche or a 88 cm niche with the included spacers.
Air intake from above.
Intermediate shelf is required.
Appliance must be fixed from underneath.
A minimum clearance of at least 150 mm from adjacent heat-sensitive furniture or contact surfaces must be observed or thermal insulation fitted.
With a total connected load of more than 11 kW local regulations concerning room ventilation, room size and combination of extraction or recirculation hoods must be observed.
Minimum clearance between gas cooktop(s) with more than 11 kW and ventilation hood 70 cm.
Appliance weight: approx. 17 kg.

Connection

Total connected load gas 12.5 kW.
Connecting cable 1.0 m without plug.

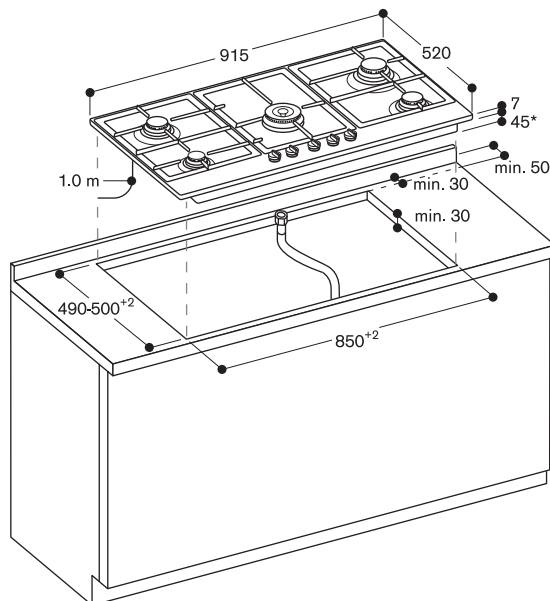
Installation of the cooktop; surface mounting

* 61 mm in the area of the gas connection at the back right



CG 261 210

Stainless steel
 Width 60 cm
 Natural gas 20 mbar
 Nozzles for liquid gas 28-30/37 mbar included

Included in the price

1 cross support for espresso
 1 wok attachment ring

Special accessories

WP 400 001
 Wok pan made of multiple-layer material
 With round bottom and handle, ø 36 cm, 6 litres, height 10 cm.

Gas cooktop 200 series

CG 261

- Mechanical power level regulation for 9 power levels, with exact setting and reproduction of flame size
- Up to 9.75 kW with burners in a diamond-shaped arrangement

Cooking zones

1 multi-ring wok burner (1550 W – 4000 W),
 1 high output burner (500 W - 3000 W), suitable for pots up to max. ø 26 cm.
 1 standard burner (290 W – 1750 W), suitable for pots up to max. ø 20 cm.
 1 economy burner (330 W – 1000 W), suitable for pots up to max. ø 16 cm.

Handling

Control knobs with cooking zone and output level markings for 9 levels.
 One-handed operation.
 Electric ignition.

Features

Two-part cast iron pan support with continuous pot surface.
 Enamelled burner cover.

Safety

Thermoelectric safety pilot.

Planning notes

The cooktop can only be surface-mounted.
 Special nozzles can be ordered as spare parts.
 Installation in a 56 cm standard niche.
 Air intake from above.
 Intermediate shelf is recommended.
 Allow for a gas connection when planning drawer depth.
 Appliance must be fixed from underneath.
 A minimum clearance of at least 100 mm from adjacent heat-sensitive furniture or contact surfaces must be observed or thermal insulation fitted.
 Appliance weight: approx. 12 kg.

Connection

Total connected load gas 9.75 kW.
 Connecting cable 1.0 m without plug.

Installation of the cooktop; surface mounting

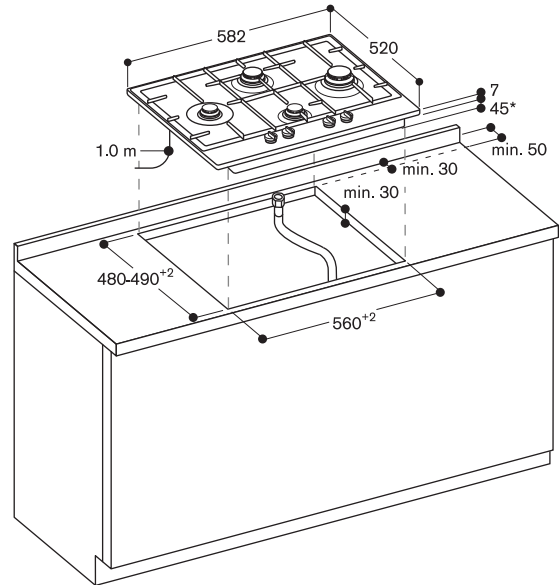

* 56 mm in the area of the gas connection at the back right



CU428100*

Integrated induction module ø 28 cm
Knob needs to be ordered separately

Necessary installation accessories

CKU410010*

Stainless steel knob 400 series for

CU 421, CU 428

Electronic control

Set of 1 knob

CKU410000*

Black knob 400 series for

CU 421, CU 428

Electronic control

Set of 1 knob

CA420000*

Installation kit for integrated induction.

One installation kit needed per kitchen

Necessary special accessories

SP415000*

Enhanced surface protector

For Pots and pans ø 15 – 18 cm

For CU 421, CU 428

SP419000*

Enhanced surface protector

For Pots and pans ø 19 – 23 cm

For CU 421, CU 428

SP424000*

Enhanced surface protector

For Pots and pans ø 24 – 28 cm

For CU 421, CU 428

SP400000*

Set of 4 enhanced surface protectors

For pots and pans ø 10 – 28 cm

For CU 421, CU 428

* Expected to be available from
May 2024

Integrated induction module 400 series CU428

- Use of cookware directly on the worktop, in combination with 12 mm Dekton worktops
- Integrated 28 cm cooking zone with booster function
- Cooking zone center light, for operation and residual heat indication directly on the surface
- Can be combined perfectly with other integrated induction modules of the 400 series
- Solid stainless steel control knob with illuminated ring, also available in black finishing

Cooking zone

1 induction cooking zone ø 28 cm
(2200 W, with booster 2700 W)

Handling

Control knobs with illuminated ring, cooking zone and output level markings for precise control.
Electronic power control in 12 output levels.
Cooking zone center light indication.

Features

Booster function.
Keep warm function.
Options menu.

Safety

Only operates with enhanced surface protector.
Operation indicator.
Pot detection.
2-stage residual heat indication directly on the surface and knob.
Safety shut-off.

Planning notes

The integrated induction module must be installed under Dekton worktops in 12 mm thickness. The bearing capacity and stability, must be supported using suitable substructures. Take into account the appliance weight and additional loads.

A 10 mm hole needs to be planned in the center of the cooking zone. Markings to indicate the cooking zone need to be planned. No other cut-outs permitted in the same worktop piece. The elaboration of the Dekton is done by local fabricators, for a list of recommended fabricators please contact your local representative. For Dekton fabricators: Refer to Specification sheet "Marking and drilling protocol for Gaggenau Induction" by Cosentino.

Minimum distances:

Cooking zone center to lateral edge of worktop 400 mm.

Cooking zone center to front and rear edge of worktop 400 mm.

Cooking zone center to next cooking zone center 450 mm or 550 mm depending on combination.

Minimum distances at the back wall of the furniture and openings, refer to dimensional drawings.

Operates with magnetic (induction) iron pots and pans only. For an optimal heat distribution, the use of sandwich bottom cookware is recommended.
Appliance weight: approx. 4.7 kg.

Please read the installation details regarding air ducting on page 210.

Connection

Total connected load 2.7 kW.

Connecting cable 1.5 m without plug.

Connecting cable 1 m for control knob.



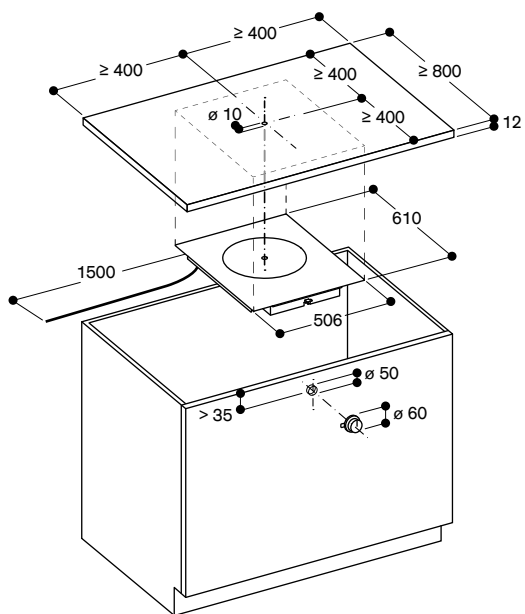

Measurements in mm

View from above

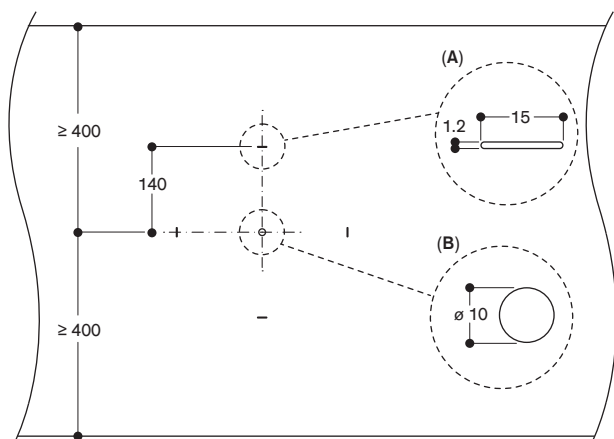

A: Surface marking
B: Drilling

Measurements in mm

Installation of the control knob

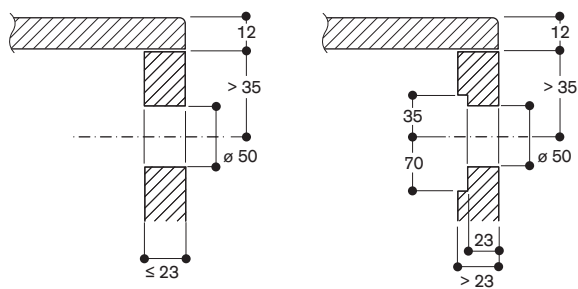

Measurements in mm

Cross section

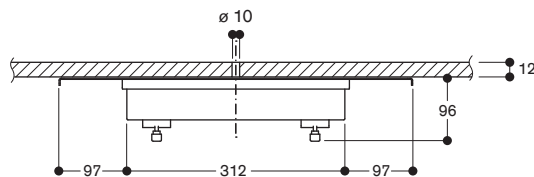

Measurements in mm

Longitudinal section

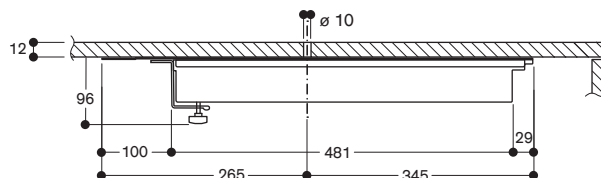

Measurements in mm



CU421100*

Integrated induction module \varnothing 21 cm
Knob needs to be ordered separately

Necessary installation accessories

CKU410010*

Stainless steel knob 400 series for

CU 421, CU 428

Electronic control

Set of 1 knob

CKU410000*

Black knob 400 series for

CU 421, CU 428

Electronic control

Set of 1 knob

CA420000*

Installation kit for integrated induction.

One installation kit needed per kitchen

Necessary special accessories

SP410000*

Enhanced surface protector

For pots and pans \varnothing 10 – 14 cm

For CU 421

SP415000*

Enhanced surface protector

For pots and pans \varnothing 15 – 18 cm

For CU 421, CU 428

SP419000*

Enhanced surface protector

For pots and pans \varnothing 19 – 23 cm

For CU 421, CU 428

SP400000*

Set of 4 enhanced surface protectors

For pots and pans \varnothing 10 – 28 cm

For CU 421, CU 428

* Expected to be available from
May 2024

Integrated induction module 400 series CU421

- Use of cookware directly on the worktop, in combination with 12 mm Dekton worktops
- Integrated 21 cm cooking zone with booster function
- Cooking zone center light, for operation and residual heat indication directly on the surface
- Can be combined perfectly with other integrated induction modules of the 400 series
- Solid stainless steel control knob with illuminated ring, also available in black finishing

Cooking zone

1 induction cooking zone \varnothing 21 cm
(2000 W, with booster 2300 W)

Handling

Control knobs with illuminated ring, cooking zone and output level markings for precise control.
Electronic power control in 12 output levels.
Cooking zone center light indication.

Features

Booster function.
Keep warm function.
Options menu.

Safety

Only operates with enhanced surface protector.
Operation indicator.
Pot detection.
2-stage residual heat indication directly on the surface and knob.
Safety shut-off.

Planning notes

The integrated induction module must be installed under Dekton worktops in 12 mm thickness. The bearing capacity and stability, must be supported using suitable substructures. Take into account the appliance weight and additional loads.

A 10 mm hole needs to be planned in the center of the cooking zone. Markings to indicate the cooking zone need to be planned. No other cut-outs permitted in the same worktop piece. The elaboration of the Dekton is done by local fabricators; for a list of recommended fabricators, please contact your local representative. For Dekton fabricators: Refer to Specification sheet "Marking and drilling protocol for Gaggenau Induction" by Cosentino.

Minimum distances:

Cooking zone center to lateral edge of worktop 350 mm.

Cooking zone center to front and rear edge of worktop 400 mm.

Cooking zone center to next cooking zone center 350 mm or 450 mm depending on combination.

Minimum distances at the back wall of the furniture and openings, refer to dimensional drawings.

Operates with magnetic (induction) iron pots and pans only. For an optimal heat distribution, the use of sandwich bottom cookware is recommended.
Appliance weight: approx. 4.5 kg.

Please read the installation details regarding air ducting on page 210.

Connection

Total connected load 2.3 kW.

Connecting cable 1.5 m without plug.

Connecting cable 1 m for control knob.



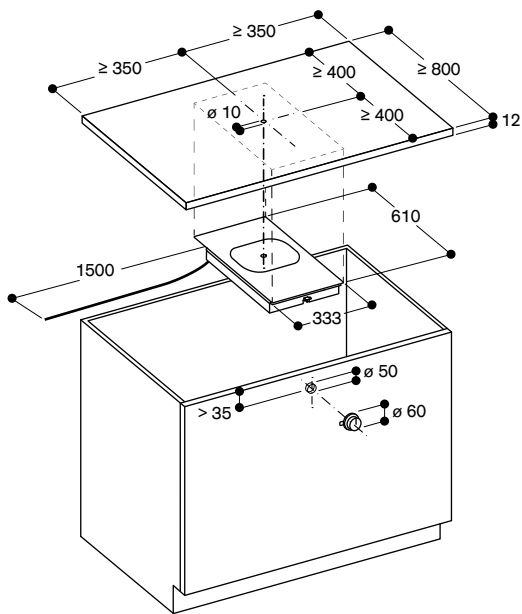

Measurements in mm

View from above

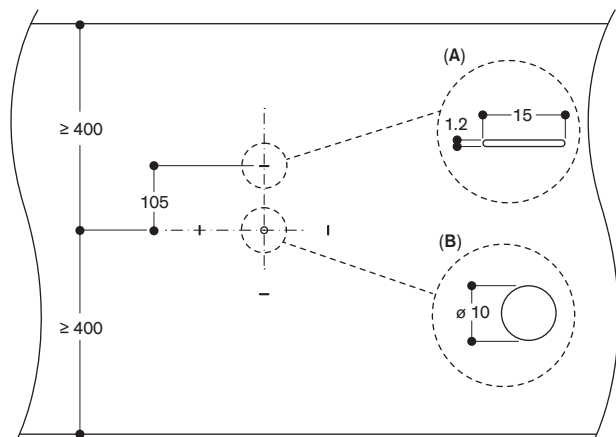

A: Surface marking
B: Drilling

Measurements in mm

Installation of the control knob

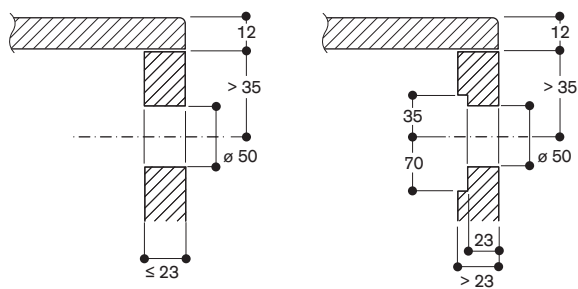

Measurements in mm

Cross section

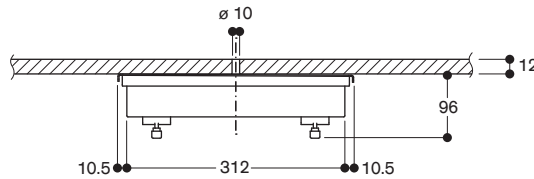

Measurements in mm

Longitudinal section

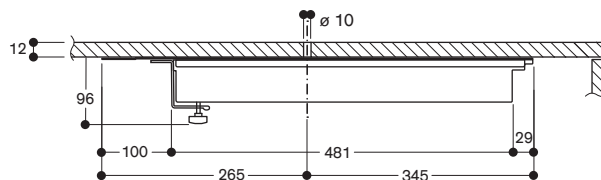

Measurements in mm

Planning examples for combinations of integrated induction modules 400 series

Good to know – for correct planning and installation

- Can only be combined with 12 mm Dekton.
- Minimum distances are mandatory.
- No other cut-outs are allowed in the same worktop piece. The worktop can consist of several pieces with joints between them to realize further cut-outs (e.g. sink).
- Holes and cooking zone markings must be pre-elaborated in the Dekton worktop by the recommended and trained fabricators.
- For a list of recommended fabricators, please contact your local representative.
- For Dekton fabricators: Refer to Specification sheet "Marking and drilling protocol for Gaggenau Induction" by Cosentino.

Planning Example 1

Combination of two medium modules – CU 421 100 and CU 421 100

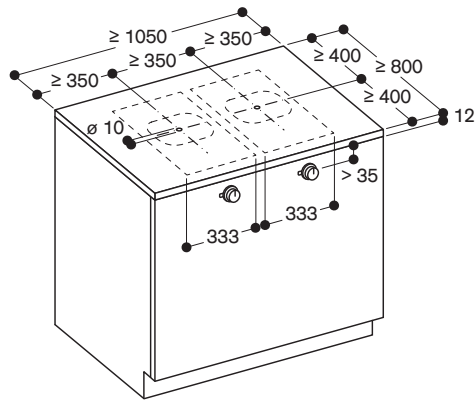

Measurements in mm

List of components (stainless steel knobs)

- 2 x CU 421 100 (Integrated induction module ø 21 cm)
- 2 x CKU 410 010 (1 knob, integrated induction, stainless steel)
- 1 x CA 420 000 (Installation kit integrated induction)
- 1 x SP 410 000 (Enhanced Surface Protector for pots and pans ø 10 – 14 cm)
- 1 x SP 415 000 (Enhanced Surface Protector for pots and pans ø 15 – 18 cm)
- 1 x SP 419 000 (Enhanced Surface Protector for pots and pans ø 19 – 23 cm)

List of components (black knobs)

- 2 x CU 421 100 (Integrated induction module ø 21 cm)
- 2 x CKU 410 000 (1 knob, integrated induction, black)
- 1 x CA 420 000 (Installation kit integrated induction)
- 1 x SP 410 000 (Enhanced Surface Protector for pots and pans ø 10 – 14 cm)
- 1 x SP 415 000 (Enhanced Surface Protector for pots and pans ø 15 – 18 cm)
- 1 x SP 419 000 (Enhanced Surface Protector for pots and pans ø 19 – 23 cm)

Recommended ventilation solutions

- AC 400 (1 filter module)
- AC 250

Planning Example 2

Combination of one medium and one large module – CU 421 100 and CU 428 100

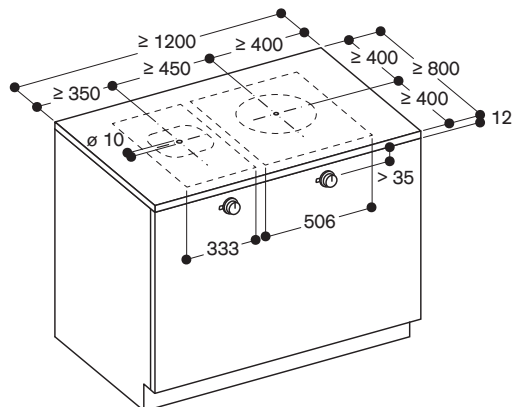

Measurements in mm

List of components (stainless steel knobs)

- 1 x CU 421 100 (Integrated induction module ø 21 cm)
- 1 x CU 428 100 (Integrated induction module ø 28 cm)
- 2 x CKU 410 010 (1 knob, integrated induction, stainless steel)
- 1 x CA 420 000 (Installation kit integrated induction)
- 1 x SP 400 000 (Set of 4 enhanced Surface Protector for pots and pans ø 10 – 28 cm)

List of components (black knobs)

- 1 x CU 421 100 (Integrated induction module ø 21 cm)
- 1 x CU 428 100 (Integrated induction module ø 28 cm)
- 2 x CKU 410 000 (1 knob, integrated induction, black)
- 1 x CA 420 000 (Installation kit integrated induction)
- 1 x SP 400 000 (Set of 4 enhanced Surface Protector for pots and pans ø 10 – 28 cm)

Recommended ventilation solutions

- AC 400 (1 filter module)
- AC 250

Planning Example 3

Combination two large modules – CU 428 100 and CU 428 100

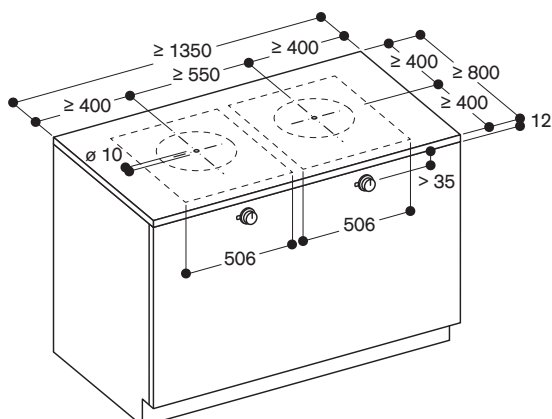

Measurements in mm

List of components (stainless steel knobs)

- 2 x CU 428 100 (Integrated induction module ø 28 cm)
- 2 x CKU 410 010 (1 knob, integrated induction, stainless steel)
- 1 x CA 420 000 (Installation kit integrated induction)
- 1 x SP 415 000 Enhanced Surface Protector for pots and pans ø 15 – 18 cm
- 1 x SP 419 000 Enhanced Surface Protector for pots and pans ø 19 – 23 cm
- 1 x SP 424 000 Enhanced Surface Protector for pots and pans ø 24 – 28 cm

List of components (black knobs)

- 2 x CU 428 100 (Integrated induction module ø 28 cm)
- 2 x CKU 410 000 (1 knob, integrated induction, black)
- 1 x CA 420 000 (Installation kit integrated induction)
- 1 x SP 415 000 Enhanced Surface Protector for pots and pans ø 15 – 18 cm
- 1 x SP 419 000 Enhanced Surface Protector for pots and pans ø 19 – 23 cm
- 1 x SP 424 000 Enhanced Surface Protector for pots and pans ø 24 – 28 cm

Recommended ventilation solutions

- AC 400 (1 filter module with fume collector or 2 filter modules)
- AC 250

Planning Example 4

Combination of two medium modules and one large module – CU 421 100 and CU 428 100 and CU 421 100

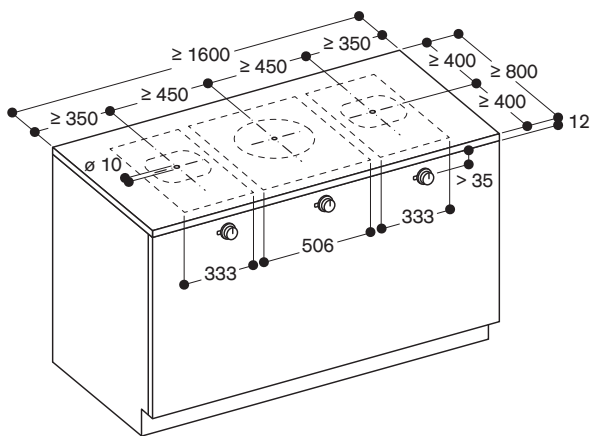

Measurements in mm

List of components (stainless steel knobs)

- 1 x CU 428 100 (Integrated induction module \varnothing 28 cm)
- 2 x CU 421 100 (Integrated induction module \varnothing 21 cm)
- 3 x CKU 410 010 (1 knob, integrated induction, stainless steel)
- 1 x CA 420 000 (Installation kit integrated induction)
- 1 x SP 400 000 (Set of 4 enhanced Surface Protector for pots and pans \varnothing 10 – 28 cm)

List of components (black knobs)

- 1 x CU 428 100 (Integrated induction module \varnothing 28 cm)
- 2 x CU 421 100 (Integrated induction module \varnothing 21 cm)
- 3 x CKU 410 000 (1 knob, integrated induction, black)
- 1 x CA 420 000 (Installation kit integrated induction)
- 1 x SP 400 000 (Set of 4 enhanced Surface Protector for pots and pans \varnothing 10 – 28 cm)

Recommended ventilation solutions

- AC 400 (2 filter modules)
- AC 250

Planning Example 5

Combination of one medium module and two large modules – CU 428 100 and CU 428 100 and CU 421 100

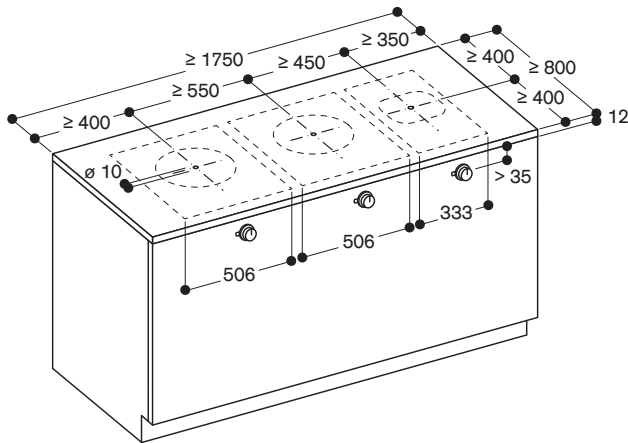

Measurements in mm

List of components (stainless steel knobs)

- 2 x CU 428 100 (Integrated induction module \varnothing 28 cm)
- 1 x CU 421 100 (Integrated induction module \varnothing 21 cm)
- 3 x CKU 410 010 (1 knob, integrated induction, stainless steel)
- 1 x CA 420 000 (Installation kit integrated induction)
- 1 x SP 400 000 (Set of 4 enhanced Surface Protector for pots and pans \varnothing 10 – 28 cm)

List of components (black knobs)

- 2 x CU 428 100 (Integrated induction module \varnothing 28 cm)
- 1 x CU 421 100 (Integrated induction module \varnothing 21 cm)
- 3 x CKU 410 000 (1 knob, integrated induction, black)
- 1 x CA 420 000 (Installation kit integrated induction)
- 1 x SP 400 000 (Set of 4 enhanced Surface Protector for pots and pans \varnothing 10 – 28 cm)

Recommended ventilation solutions

- AC 400 (2 filter modules)
- AC 250 with fume collector

Planning Example 6

Combination of 2 medium modules and two large modules – CU 421 100 and CU 428 100 and CU 428 100 and CU 421 100

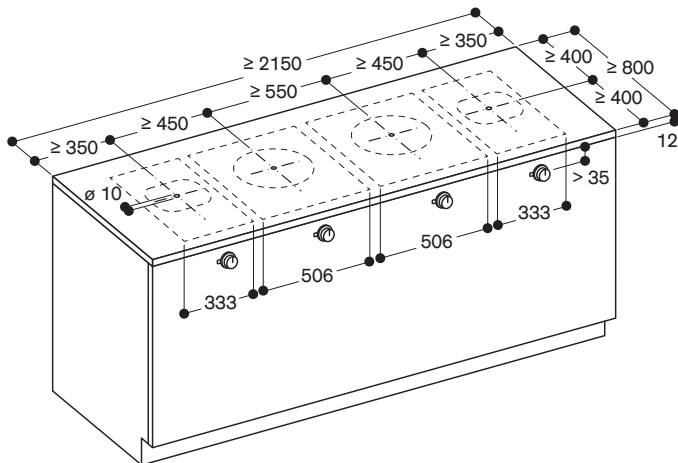

Measurements in mm

List of components (stainless steel knobs)

- 2 x CU 428 100 (Integrated induction module \varnothing 28 cm)
- 2 x CU 421 100 (Integrated induction module \varnothing 21 cm)
- 4 x CKU 410 010 (1 knob, integrated induction, stainless steel)
- 1 x CA 420 000 (Installation kit integrated induction)
- 1 x SP 400 000 (Set of 4 enhanced Surface Protector for pots and pans \varnothing 10 – 28 cm)

List of components (black knobs)

- 2 x CU 428 100 (Integrated induction module \varnothing 28 cm)
- 2 x CU 421 100 (Integrated induction module \varnothing 21 cm)
- 4 x CKU 410 000 (1 knob, integrated induction, black)
- 1 x CA 420 000 (Installation kit integrated induction)
- 1 x SP 400 000 (Set of 4 enhanced Surface Protector for pots and pans \varnothing 10 – 28 cm)

Recommended ventilation solutions

- AC 400 (2 filter modules with fume collector)



CX 492 101

Black glass ceramic
Frameless
Width 90 cm

Included in the price

1 wireless cooking sensor for temperature regulation

Special accessories

CA 060 300

Cooking sensor for temperature regulation within pots

GN 232 110

Teppan Yaki plate made of multi ply material,

GN 1/1

For full surface induction cooktops.

GN 232 230

Teppan Yaki plate made of multi ply material,

GN 2/3

For full surface induction cooktops.

Full surface induction cooktop 400 series

CX 492

- One single big cooking surface
- Free positioning of cookware
- All sizes and formats of cookware can be used
- TFT touch display for an intuitive control of all functions
- Cooking sensor function for temperature control in pots
- Professional cooking functions
- Max. power output for big cookware of up to 5.5 kW
- Frameless for flush mounting

Cooking zones

One unique cooking surface of 3200 cm².
Up to 6 items of cookware can be placed simultaneously on the cooktop.

Handling

Easy to use colour graphic TFT touch display with use indications.
Electronic power control in 17 output levels.

Features

Cooking sensor function.
Professional cooking function.
Dynamic cooking function.
Teppan Yaki function.
Booster function for pots.
Booster function for pans.
Keep warm function.
Individual pot detection.
Cooking timer for each cooking position.
Stopwatch.
Short-term timer.
Information key with use indicators.
Power management.

Selected digital services (Home Connect)

Cooktop-based ventilation control (with suitable hood).
Remote monitoring.
Remote diagnostics.

Please read additional information on Home Connect on page 411.

Safety

Main switch.
Residual heat indication.
Child lock.
Safety shut-off.
Pause function.

Planning notes

Operates with magnetic (induction) iron pots and pans only. For an optimal heat distribution, the use of sandwich bottom cookware is recommended. The wok pan WP 400 001 cannot be used with this appliance. Installation is possible in worktops made of stone, synthetics or solid wood. Heat resistance and watertight sealing of the cut edges must be observed. Concerning other materials please consult the worktop manufacturer. The bearing capacity and stability, in the case of thin worktops in particular, must be supported using suitable substructures. Take into account the appliance weight and additional loads. The groove must be continuous and even, so that uniform placing of the appliance on the gasket is ensured.

Do not use discontinuous lining.
Appliance must be fixed from underneath.
Joint width may vary due to dimensional tolerances of the glass ceramic cooktop and the worktop cut-out.
Appliance weight: approx. 31 kg.

Please read the installation details regarding air ducting on page 210.

Please read additional planning notes on page 130 – 134.

Connection

Total connected load 7.4 kW.
Connecting cable 1.5 m without plug.
Power consumption standby/display off 0.5 W.
Power consumption standby/network 2.0 W.
Please check the user manual for how to switch off the WiFi module.

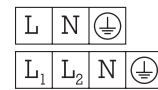

Installation of the cooktop; flush mounting

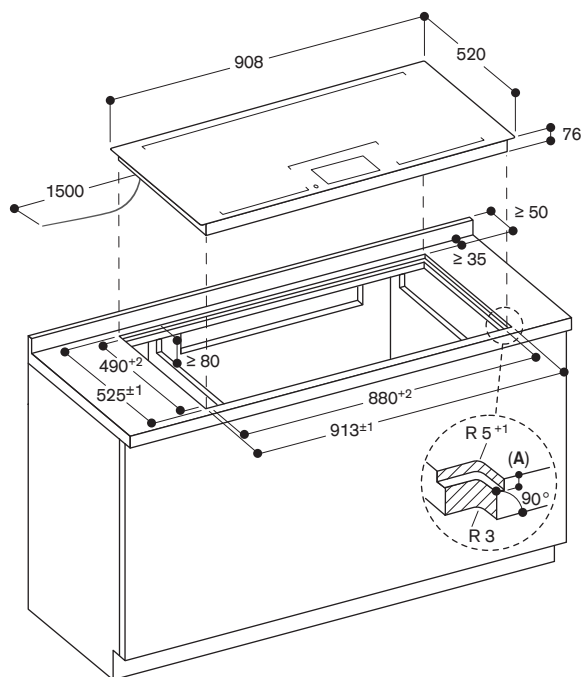

A: $6,5^{+0,5}$

measurements in mm

View from above

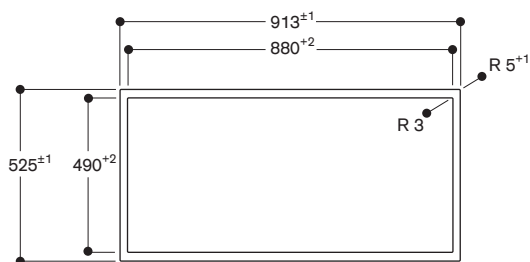

measurements in mm

Longitudinal section

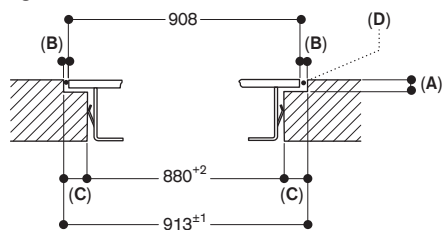

A: $6,5^{+0,5}$

B: 2,5

C: 16,5

D: Fill with silicone

measurements in mm

Cross-section

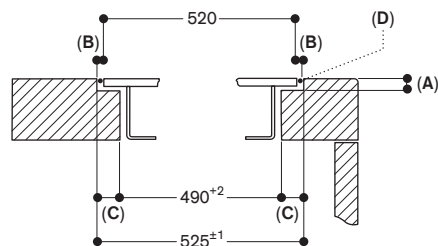

A: $6,5^{+0,5}$

B: 2,5

C: 17,5

D: Fill with silicone

measurements in mm



CX 492 111

Black glass ceramic
Stainless steel frame
Width 90 cm

Included in the price

1 wireless cooking sensor for temperature regulation

Installation accessories

VA 420 004

Connection strip for combination with other Vario appliances of the 400 series for flush mounting

VA 420 010

Connection strip for combination with other Vario appliances of the 400 series for surface mounting

Special accessories

CA 060 300

Cooking sensor for temperature regulation within pots

GN 232 110

Teppan Yaki plate made of multi ply material,
GN 1/1

For full surface induction cooktops.

GN 232 230

Teppan Yaki plate made of multi ply material,
GN 2/3

For full surface induction cooktops.

Full surface induction cooktop 400 series

CX 492

- One single big cooking surface
- Free positioning of cookware
- All sizes and formats of cookware can be used
- TFT touch display for an intuitive control of all functions
- Cooking sensor function for temperature control in pots
- Professional cooking functions
- Max. power output for big cookware of up to 5.5 kW
- Precision crafted 3 mm stainless steel
- For surface mounting with a visible edge or for flush mounting
- Can be combined perfectly with other Vario appliances of the 400 series

Cooking zones

One unique cooking surface of 3200 cm².

Up to 6 items of cookware can be placed simultaneously on the cooktop.

Handling

Easy to use colour graphic TFT touch display with use indications.

Electronic power control in 17 output levels.

Features

Cooking sensor function.

Professional cooking function.

Dynamic cooking function.

Teppan Yaki function.

Booster function for pots.

Booster function for pans.

Keep warm function.

Individual pot detection.

Cooking timer for each cooking position.

Stopwatch.

Short-term timer.

Information key with use indicators.

Power management.

Selected digital services (Home Connect)

Cooktop-based ventilation control (with suitable hood).

Remote monitoring.

Remote diagnostics.

Please read additional information on Home Connect on page 411.

Safety

Main switch.

Residual heat indication.

Child lock.

Safety shut-off.

Pause function.

Planning notes

Depending on the type of installation (surface-mounted or flush-mounted), the specific definition of the cut-out must be observed.

If combining several Vario appliances of the 400 series, select combinations with or without appliance cover, and a connection strip VA 420 must be placed between the appliances.

Depending on the type of installation, the corresponding connection strip must be provided.

The bearing capacity and stability, in the case of thinner worktops in particular, must be supported using suitable substructures. Take into account the appliance weight and additional loads. Additional instructions for flush mounting: Installation is possible in worktops made of stone, synthetics or solid wood. Heat resistance and watertight sealing of the cut edges must be observed. Concerning other materials please consult the worktop manufacturer. The groove must be continuous and even, so that uniform placing of the appliance on the gasket is ensured. Do not use discontinuous lining. The joint width may vary due to size tolerances of the combinations and of the worktop cut-out.

Please read additional planning notes on page 130 and 132.

If installing several appliances in individual cut-outs allow for a division bar of minimum 50 mm between the individual cut-outs.

Operates with magnetic (induction) iron pots and pans only. For an optimal heat distribution, the use of sandwich bottom cookware is recommended.

The wok pan WP 400 001 cannot be used with this appliance.

Appliance can be snapped into the worktop from above.

Appliance weight: approx. 31 kg.

Please read the installation details regarding air ducting on page 210.

Connection

Total connected load 7.4 kW.

Connecting cable 1.5 m without plug.

Power consumption standby/
display off 0.5 W.

Power consumption standby/
network 2.0 W.

Please check the user manual for how to switch off the WiFi module.

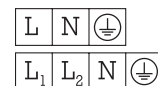

Installation of the cooktop; surface mounting

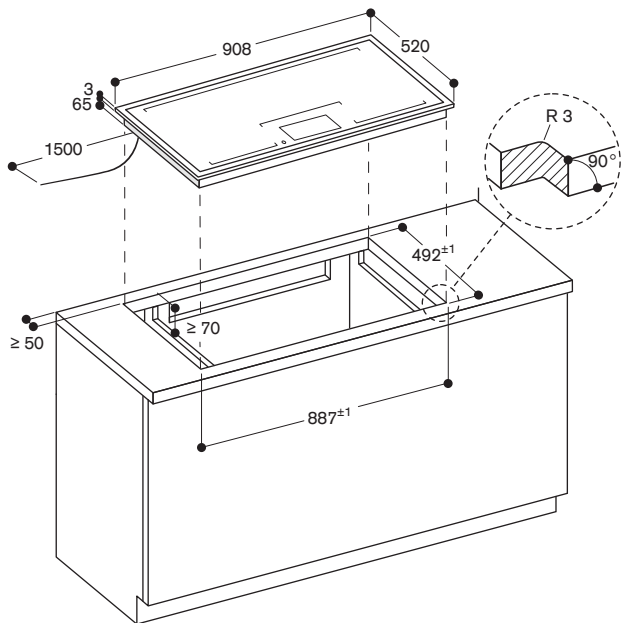

measurements in mm

Installation of the cooktop; flush mounting

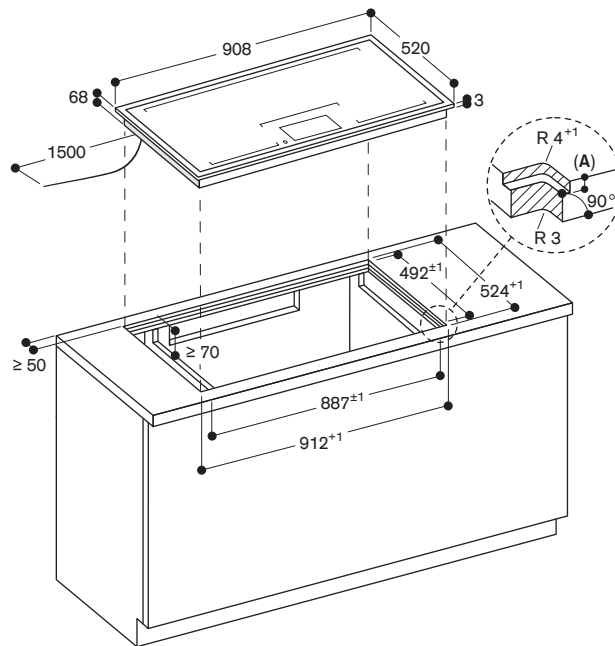

A: 3.5^{0.5}

measurements in mm

View from above

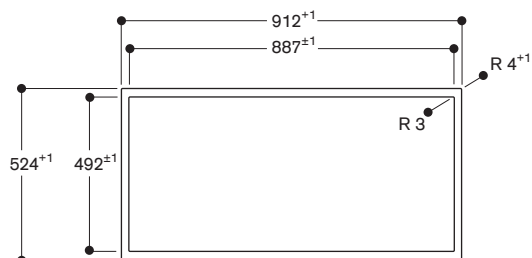

measurements in mm

Longitudinal section

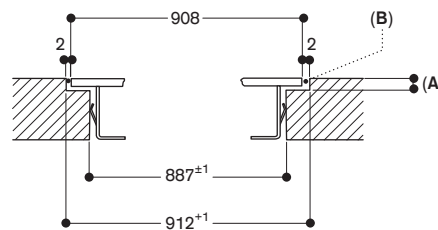

A: 3.5^{0.5}

B: Fill with silicone

measurements in mm

Cross-section

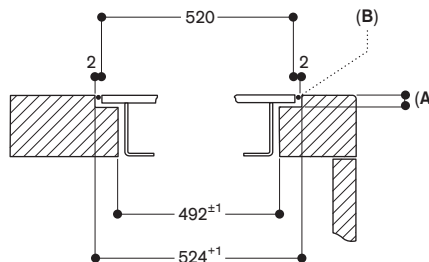

A: 3.5^{0.5}

B: Fill with silicone

measurements in mm



CX 482 101

Black glass ceramic
Frameless
Width 80 cm

Included in the price

1 wireless cooking sensor for temperature regulation

Special accessories

CA 060 300

Cooking sensor for temperature regulation within pots

GN 232 110

Teppan Yaki plate made of multi ply material,

GN 1/1

For full surface induction cooktops.

GN 232 230

Teppan Yaki plate made of multi ply material,

GN 2/3

For full surface induction cooktops.

Full surface induction cooktop 400 series

CX 482

- One single big cooking surface
- Free positioning of cookware
- All sizes and formats of cookware can be used
- TFT touch display for an intuitive control of all functions
- Cooking sensor function for temperature control in pots
- Professional cooking functions
- Max. power output for big cookware of up to 5.5 kW
- Frameless for flush mounting

Cooking zones

One unique cooking surface of 2750 cm².
Up to 5 items of cookware can be placed simultaneously on the cooktop.

Handling

Easy to use colour graphic TFT touch display with use indications.
Electronic power control in 17 output levels.

Features

Cooking sensor function.
Professional cooking function.
Dynamic cooking function.
Teppan Yaki function.
Booster function for pots.
Booster function for pans.
Keep warm function.
Individual pot detection.
Cooking timer for each cooking position.
Stopwatch.
Short-term timer.
Information key with use indicators.
Power management.

Selected digital services (Home Connect)

Cooktop-based ventilation control (with suitable hood).
Remote monitoring.
Remote diagnostics.

Please read additional information on Home Connect on page 411.

Safety

Main switch.
Residual heat indication.
Child lock.
Safety shut-off.
Pause function.

Planning notes

Operates with magnetic (induction) iron pots and pans only. For an optimal heat distribution, the use of sandwich bottom cookware is recommended. The wok pan WP 400 001 cannot be used with this appliance. Installation is possible in worktops made of stone, synthetics or solid wood. Heat resistance and watertight sealing of the cut edges must be observed. Concerning other materials please consult the worktop manufacturer. The bearing capacity and stability, in the case of thin worktops in particular, must be supported using suitable substructures. Take into account the appliance weight and additional loads. The groove must be continuous and even, so that uniform placing of the appliance on the gasket is ensured. Do not use discontinuous lining.

Appliance must be fixed from underneath. Joint width may vary due to dimensional tolerances of the glass ceramic cooktop and the worktop cut-out. Appliance weight: approx. 26 kg.

Please read the installation details regarding air ducting on page 210.

Please read additional planning notes on page 130 – 134.

Connection

Total connected load 7.4 kW.
Connecting cable 1.5 m without plug.
Power consumption standby/
display off 0.5 W.
Power consumption standby/
network 2.0 W.
Please check the user manual for how to switch off the WiFi module.

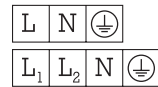

Installation of the cooktop; flush mounting

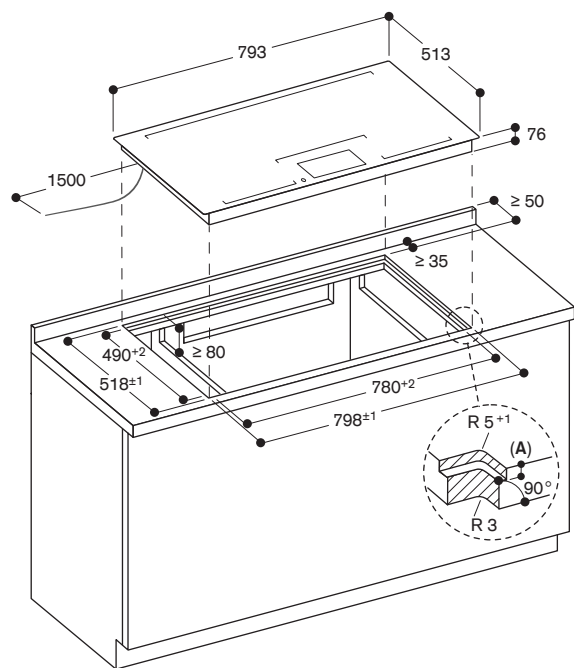

A: $6.5^{+0.5}$

measurements in mm

View from above

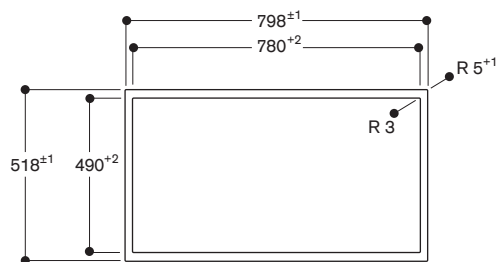

measurements in mm

Longitudinal section

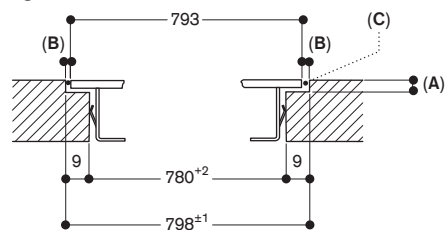

A: $6.5^{+0.5}$

B: 2.5
C: Fill with silicone

measurements in mm

Cross-section

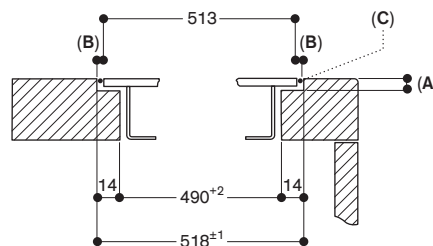

A: $6.5^{+0.5}$

B: 2.5

C: Fill with silicone

measurements in mm



CX 482 111

Black glass ceramic
Stainless steel frame
Width 80 cm

Included in the price

1 wireless cooking sensor for temperature regulation

Installation accessories

VA 420 004

Connection strip for combination with other Vario appliances of the 400 series for flush mounting

VA 420 010

Connection strip for combination with other Vario appliances of the 400 series for surface mounting

Special accessories

CA 060 300

Cooking sensor for temperature regulation within pots

GN 232 110

Teppan Yaki plate made of multi ply material,
GN 1/1

For full surface induction cooktops.

GN 232 230

Teppan Yaki plate made of multi ply material,
GN 2/3

For full surface induction cooktops.

Full surface induction cooktop 400 series

CX 482

- One single big cooking surface
- Free positioning of cookware
- All sizes and formats of cookware can be used
- TFT touch display for an intuitive control of all functions
- Cooking sensor function for temperature control in pots
- Professional cooking functions
- Max. power output for big cookware of up to 5.5 kW
- Precision crafted 3 mm stainless steel
- For surface mounting with a visible edge or for flush mounting
- Can be combined perfectly with other Vario appliances of the 400 series

Cooking zones

One unique cooking surface of 2750 cm².
Up to 5 items of cookware can be placed simultaneously on the cooktop.

Handling

Easy to use colour graphic TFT touch display with use indications.
Electronic power control in 17 output levels.

Features

Cooking sensor function.
Professional cooking function.
Dynamic cooking function.
Teppan Yaki function.
Booster function for pots.
Booster function for pans.
Keep warm function.
Individual pot detection.
Cooking timer for each cooking position.
Stopwatch.
Short-term timer.
Information key with use indicators.
Power management.

Selected digital services (Home Connect)

Cooktop-based ventilation control (with suitable hood).
Remote monitoring.
Remote diagnostics.

Please read additional information on Home Connect on page 411.

Safety

Main switch.
Residual heat indication.
Child lock.
Safety shut-off.
Pause function.

Planning notes

Depending on the type of installation (surface-mounted or flush-mounted), the specific definition of the cut-out must be observed.
If combining several Vario appliances of the 400 series, select combinations with or without appliance cover, and a connection strip VA 420 must be placed between the appliances.
Depending on the type of installation, the corresponding connection strip must be provided.

The bearing capacity and stability, in the case of thinner worktops in particular, must be supported using suitable substructures. Take into account the appliance weight and additional loads. Additional instructions for flush mounting: Installation is possible in worktops made of stone, synthetics or solid wood. Heat resistance and watertight sealing of the cut edges must be observed. Concerning other materials please consult the worktop manufacturer. The groove must be continuous and even, so that uniform placing of the appliance on the gasket is ensured. Do not use discontinuous lining. The joint width may vary due to size tolerances of the combinations and of the worktop cut-out.

Please read additional planning notes on page 130 and 132.

If installing several appliances in individual cut-outs allow for a division bar of minimum 50 mm between the individual cut-outs.
Operates with magnetic (induction) iron pots and pans only. For an optimal heat distribution, the use of sandwich bottom cookware is recommended. The wok pan WP 400 001 cannot be used with this appliance.
Appliance can be snapped into the worktop from above.
Appliance weight: approx. 27 kg.

Please read the installation details regarding air ducting on page 210.

Connection

Total connected load 7.4 kW.
Connecting cable 1.5 m without plug.
Power consumption standby/display off 0.5 W.
Power consumption standby/network 2.0 W.
Please check the user manual for how to switch off the WiFi module.

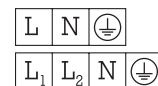

Installation of the cooktop; surface mounting

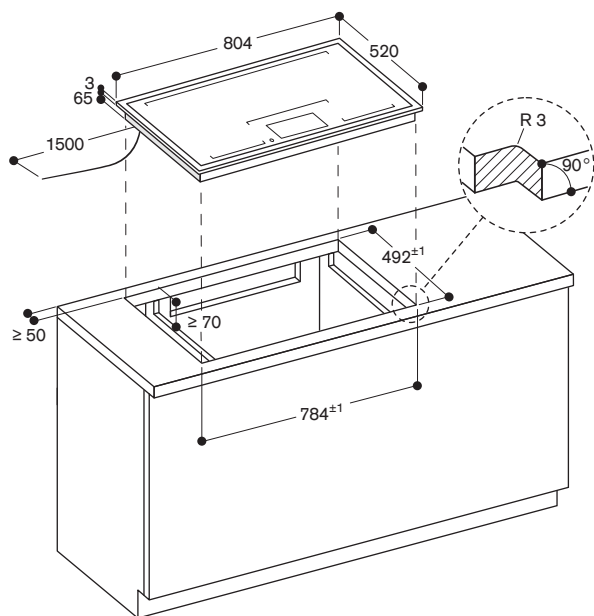

measurements in mm

Installation of the cooktop; flush mounting

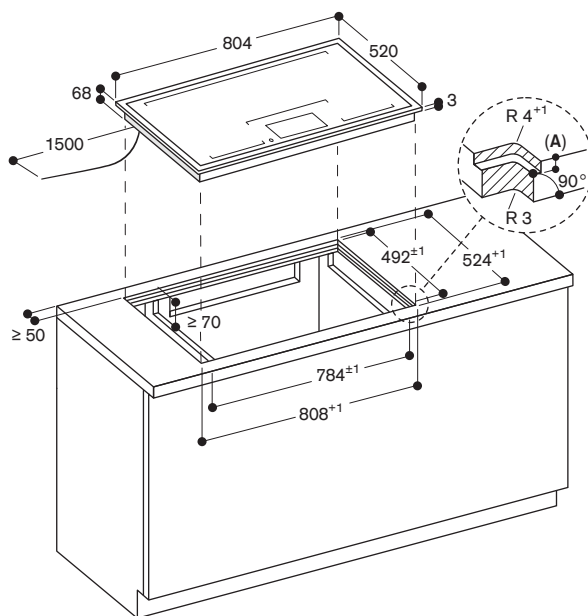

A: 3.5^{0.5}

measurements in mm

View from above

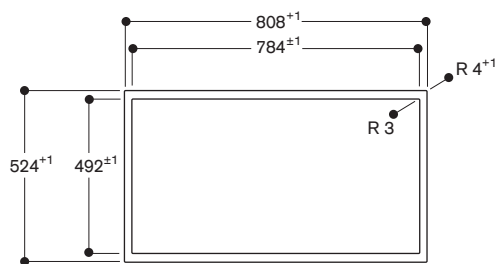

measurements in mm

Longitudinal section

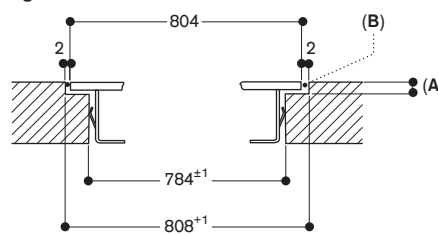

A: 3.5^{0.5}

B: Fill with silicone

measurements in mm

Cross-section

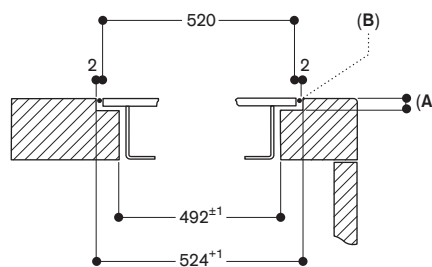

A: 3.5^{0.5}

B: Fill with silicone

measurements in mm



CV 492 105

Frameless
Width 90 cm
Air extraction / Air recirculation
Ducting needs to be ordered separately
Knobs need to be ordered separately



Necessary installation accessories

CKI 440 010
Stainless steel knobs 400 series for VI 462, VI 482, CV 482, CV 492
Electronic control
Set of 4 knobs

CKI 440 000
Black knobs 400 series for VI 462, VI 482, CV 482, CV 492
Electronic control
Set of 4 knobs

CA 082 011
Kit unducted air recirculation

CA 082 061
Kit ducted air recirculation, 60 cm worktop depth

CA 082 071
Kit ducted air recirculation, 70 cm worktop depth

CA 084 010
4 acoustic filters for air extraction mode

Special accessories

CA 051 301
Teppan Yaki plate made of multi ply material
For flex induction cooktop.

CA 052 300
Griddle plate in cast aluminium
Non-stick.

For flex induction cooktop.

CA 050 300
Flex Pan set, 3 pcs.
Non-stick coating.

For flex induction cooktop.

CA 055 300
Flex Pan large
Non-stick coating.

For flex induction cooktop.

CA 282 112
4 activated charcoal filters with highly efficient odour reduction and allergen deactivation.

Installation accessories for air ducting you will find at the pages 287 – 293.

Flex induction cooktop with integrated ventilation system 400 series CV 492

- Flex function for combining the rectangular cooking areas
- Free positioning of cookware inside combined cooking areas with automatic extension up to 30 cm width
- Highly efficient ventilation system integrated in the cooktop
- Fully automatic ventilation system functions
- Large-scale metal grease filter, easy to remove, dishwasher-safe
- Energy-saving, low-noise fan
- Air extraction or air recirculation system
- Integrated activated charcoal filter easily removeable from above for air recirculation system
- Solid stainless steel control knob with black coating
- Easy control of all functions with bicoloured display

Cooking zones

2 flex induction cooking areas 23x20 cm (2200 W, with booster 3700 W), linked together 23x40 cm (3300 W, with booster 3700 W), with automatic extension up to 32x30 cm (3300 W, with booster 3700 W).
2 flex induction cooking areas 23x20 cm (2200 W, with booster 3700 W), linked together 23x40 cm (3300 W, with booster 3700 W), with automatic extension up to 32x30 cm (3300 W, with booster 3700 W).

Performance of ventilation system

Performance and noise level, output level 3/Intensive:
Air output according to EN61591.
Sound power level according to EN 60704-3.
Air extraction:
532 / 636 m³/h.
70 / 74 dB (A) re 1 pW.
Air recirculation:
487 / 611 m³/h.
67 / 72 dB (A) re 1 pW.

Handling

Control knobs with illuminated ring, cooking zone and output level markings.
Electronic power control in 12 output levels.
User friendly control with bicoloured display (white / orange).
Control of ventilation system with 3 electronically controlled power levels and 1 intensive mode.

Features

Flex function for rectangular cooking areas.
Frying sensor function.
Booster function.
Automatic sensor-controlled performance adjustment of the ventilation system.
Automatic activation of the ventilation system when a cooking zone is used.
Interval ventilation, 6 min.
Automatic sensor controlled or manual run on function.
Activated charcoal filter saturation indicator.
Removable, dishwasher-safe grease filter unit.

High-grade black zinc die-casted cover for ventilation system, dishwasher-safe.
Fan technology with highly efficient, brushless DC motor (BLDC).
Airflow-optimised interior for efficient air circulation.
Stopwatch.
Short-term timer.
Memory function.
Options menu.
Power management.

Selected digital services

(Home Connect)
Remote control and monitoring of ventilation.
Remote monitoring of cooking zones.
Remote diagnostics.

Please read additional information on Home Connect on page 411.

Consumption data

Energy efficiency class A at a range of energy efficiency classes from A+++ to D.
Energy consumption 56.9 kWh/year.
Ventilation efficiency class A.
Illumination efficiency class -.
Grease filter efficiency class B.
Sound level min. 61 dB / max. 70 dB normal mode.

Safety

Operation indicator.
Pot detection.
2-stage residual heat indication.
Safety shut-off.
Detachable, dishwasher-safe two-stage overflow protection.
Removable overflow container, 0,9-litre capacity, dishwasher-safe.

Planning notes

Bottom cabinet width: min. 60 cm.
Worktop depth: min. 60 cm.
The unducted recirculation set CA 082 011 requires a vertical aperture of min. 25 mm behind the backpanel of the furniture. Suggested for ideal performance are 50 mm.
The air outlet on the backside of the appliance can directly be accessed with a flat duct element (DN 150).
In air extraction mode a one-way flap with a maximum opening pressure of 65 Pa should be installed.
For optimum performance in air recirculation we recommend an outflow surface area of at least 440 cm².
Operates with magnetic (induction) iron pots and pans only. For an optimal heat distribution, the use of sandwich bottom cookware is recommended.

Special accessories

(please order as spare parts):
Part No. 17006018
Frying sensor pan, ø 20 cm
Part No. 17006184
Frying sensor pan, ø 24 cm
Part No. 17006185
Frying sensor pan, ø 28 cm
Part No. 17006019
Frying sensor pan, ø 32 cm

The equivalent ducting length to ensure good performance is L_{max} 28 m.
The appliance must be freely accessible from below.

Appliance must be fixed from underneath.
Appliance weight: approx. 30 kg.
When installing a ventilation hood with air extraction mode and a chimney-vented fireplaces, the power supply line of the ventilation appliance needs a suitable safety switch.

Installation is possible in worktops made of stone, synthetics or solid wood. Heat resistance and watertight sealing of the cut edges must be observed. Concerning other materials please consult the worktop manufacturer. The bearing capacity and stability, in the case of thin worktops in particular, must be supported using suitable substructures. Take into account the appliance weight and additional loads. The groove must be continuous and even, so that uniform placing of the appliance on the gasket is ensured. Do not use discontinuous lining. Joint width may vary due to dimensional tolerances of the glass ceramic cooktop and the worktop cut-out. Comply with the clearances from underneath the worktop to the overflow container: min. 300 mm to remove and empty the container.

Please read additional planning notes on page 188 – 189.

Connection

Total connected load 7.4 kW.
Connecting cable 1.5 m without plug.
Connecting cables 0.3 m and 1 m for control knobs.
Power consumption standby/display off 0.5 W.
Power consumption standby/network 2.0 W.
Please check the user manual for how to switch off the WiFi module.

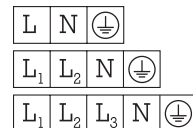

*Energy efficiency class: at a range of energy efficiency classes from A+++ to D.

Installation of the cooktop; flush mounting

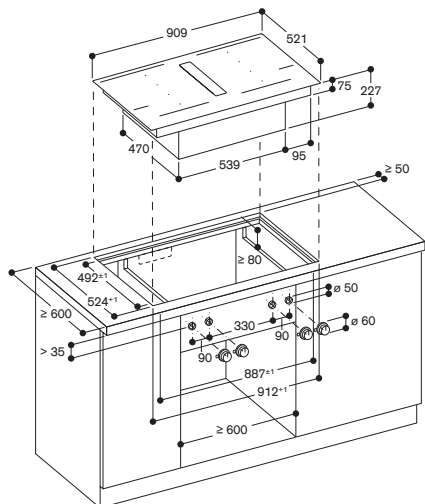

Measurements in mm

Installation of the control knob

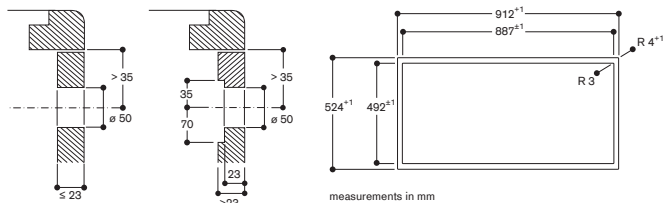

measurements in mm

Longitudinal section

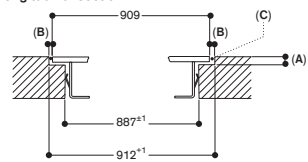

A: 6.5^{-0.5}
B: 1.5
C: Fill with silicone
measurements in mm

Cross-section

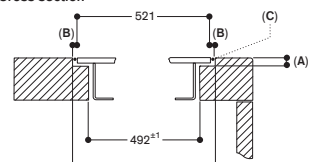

A: 6.5^{-0.5}
B: 1.5
C: Fill with silicone
measurements in mm

Front view

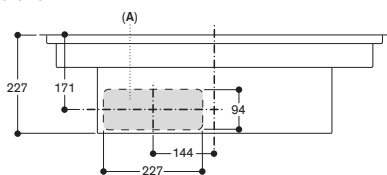

A: Connected directly at the rear
measurements in mm

Side view with unducted recirculation; flush mounting

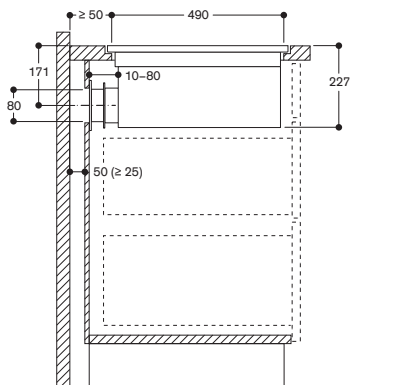

Not recommended for non-thermally insulated outer wall or floor ($U \geq 0.5 \text{ W/m}^2\text{K}$)

Measurements in mm

Front view – furniture cut-out for unducted recirculation; flush mounting

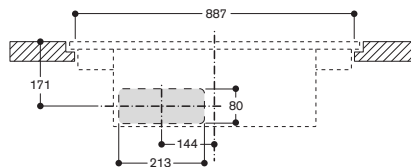

measurements in mm

Front view of CV 492 with ducted recirculation

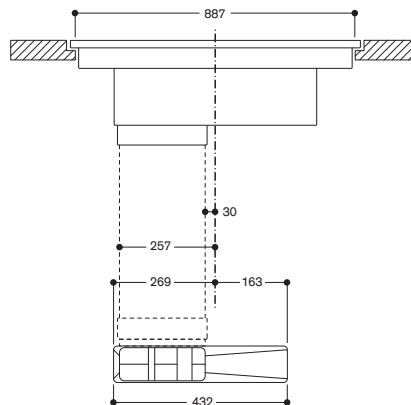

measurements in mm

Side view with kit ducted air recirculation 700 mm worktop depth; flush mounting

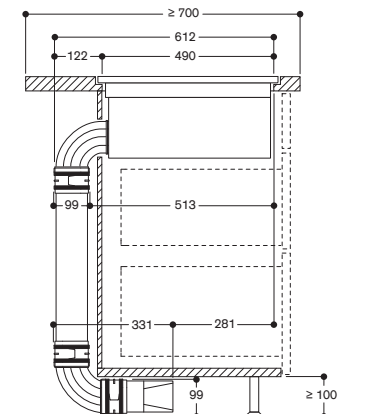

Not recommended for non-thermally insulated floor ($U \geq 0.5 \text{ W/m}^2\text{K}$)

Measurements in mm

Side view with kit ducted air recirculation 600 mm worktop depth; flush mounting

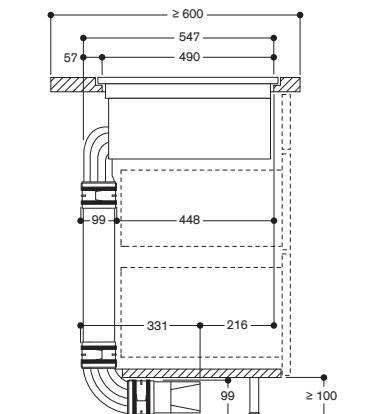

Not recommended for non-thermally insulated floor ($U \geq 0.5 \text{ W/m}^2\text{K}$)

Measurements in mm



CV 482 105

Frameless
Width 80 cm
Air extraction / Air recirculation
Ducting needs to be ordered separately
Knobs need to be ordered separately



Necessary installation accessories

CKI 440 010
Stainless steel knobs 400 series for VI 462, VI 482, CV 482, CV 492
Electronic control
Set of 4 knobs

CKI 440 000
Black knobs 400 series for VI 462, VI 482, CV 482, CV 492
Electronic control
Set of 4 knobs

CA 082 011
Kit unducted air recirculation

CA 082 061
Kit ducted air recirculation, 60 cm worktop depth

CA 082 071
Kit ducted air recirculation, 70 cm worktop depth

CA 084 010
4 acoustic filters for air extraction mode

Special accessories

CA 051 301
Teppan Yaki plate made of multi ply material
For flex induction cooktop.

CA 052 300
Griddle plate in cast aluminium
Non-stick.
For flex induction cooktop.

CA 050 300
Flex Pan set, 3 pcs.
Non-stick coating.
For flex induction cooktop.

CA 055 300
Flex Pan large
Non-stick coating.
For flex induction cooktop.

CA 282 112
4 activated charcoal filters with high efficient odour reduction for air recirculation mode.

Installation accessories for air ducting you will find at the pages 287 – 293.

Flex induction cooktop with integrated ventilation system 400 series CV 482

- Flex function for combining the rectangular cooking areas
- Free positioning of cookware inside combined cooking areas
- Highly efficient ventilation system integrated in the cooktop
- Fully automatic ventilation system functions
- Large-scale metal grease filter, easy to remove, dishwasher-safe
- Energy-saving, low-noise fan
- Air extraction or air recirculation system
- Integrated activated charcoal filter easily removeable from above for air recirculation system
- Solid stainless steel knob, also selectable with black robust finishing, for precise control and personalisation
- Frameless for flush mounting

Cooking zones

2 flex induction cooking areas 24x20 cm (2200 W, with booster 3700 W), linked together 24x40 cm (3300 W, with booster 3700 W).

2 flex induction cooking areas 24x20 cm (2200 W, with booster 3700 W), linked together 24x40 cm (3300 W, with booster 3700 W).

Performance of ventilation system

Performance and noise level, output level 3/Intensive:

Air output according to EN61591.

Sound power level according to EN 60704-3.

Air extraction:

532 / 636m³/h.

70 / 74 dB (A) re 1 pW.

Air recirculation:

487 / 611m³/h.

67 / 72 dB (A) re 1 pW.

Handling

Control knobs with illuminated ring, cooking zone and output level markings.

Electronic power control in 12 output levels.

User friendly control with bicoloured display (white / orange).

Control of ventilation system with 3 electronically controlled power levels and 1 intensive mode.

Features

Flex function for rectangular cooking areas.

Frying sensor function.

Booster function.

Automatic sensor-controlled performance adjustment of the ventilation system.

Automatic activation of the ventilation system when a cooking zone is used. Interval ventilation, 6 min.

Automatic sensor-controlled or manual run-on function.

Grease filter and activated charcoal filter saturation indicator.

Removable, dishwasher-safe grease filter unit.

High-grade black zinc die-casted cover for ventilation system, dishwasher-safe.

Fan technology with highly efficient, brushless DC motor (BLDC).

Airflow-optimised interior for efficient air circulation.

Stopwatch.

Short-term timer.

Memory function.

Options menu.

Power management.

Selected digital services

(Home Connect)

Remote control and monitoring of ventilation.

Remote monitoring of cooking zones.

Remote diagnostics.

Please read additional information on Home Connect on page 411.

Consumption data

Energy efficiency class A at a range of energy efficiency classes from A+++ to D.

Energy consumption 56.9 kWh/year.

Ventilation efficiency class A.

Illumination efficiency class -.

Grease filter efficiency class B.

Sound level min. 61 dB / max. 70 dB normal mode.

Safety

Operation indicator.

Pot detection.

2-stage residual heat indication.

Child lock.

Safety shut-off.

Detachable, dishwasher-safe two-stage overflow protection.

Removable overflow container,

0,9-litre capacity, dishwasher-safe.

Planning notes

Bottom cabinet width: min. 60 cm.

Worktop depth: min. 60 cm.

Immersion depth 227 mm.

The unducted recirculation set CA 082 011 requires a vertical aperture of min. 25 mm behind the backpanel of the furniture. Suggested for ideal performance are 50 mm.

The air outlet on the backside of the appliance can directly be accessed with a flat duct element (DN 150).

In air extraction mode a one-way flap with a maximum opening pressure of 65 Pa should be installed.

For optimum performance in air recirculation we recommend an outflow surface area of at least 440 cm².

Operates with magnetic (induction) iron pots and pans only. For an optimal heat distribution, the use of sandwich bottom cookware is recommended.

Special accessories

(please order as spare parts):

Part No. 17006018

Frying sensor pan, ø 20 cm

Part No. 17006184

Frying sensor pan, ø 24 cm

The equivalent ducting length to ensure good performance is L_{max} 28 m.

The appliance must be freely accessible from below.

Appliance must be fixed from underneath.

Appliance weight: approx. 30 kg.

When installing a ventilation hood with air extraction mode and a chimney-vented fireplace, the power supply line of the ventilation appliance needs a suitable safety switch.

Installation is possible in worktops made of stone, synthetics or solid wood. Heat resistance and watertight sealing of the cut edges must be observed. Concerning other materials please consult the worktop manufacturer. The bearing capacity and stability, in the case of thinner worktops in particular, must be supported using suitable substructures. Take into account the appliance weight and additional loads.

The groove must be continuous and even, so that uniform placing of the appliance on the gasket is ensured. Do not use discontinuous lining. Joint width may vary due to dimensional tolerances of the glass ceramic cooktop and the worktop cut-out. Comply with the clearances from underneath the worktop to the overflow container: min. 300 mm to remove and empty the container.

Please read additional planning notes on page 188 – 189.

Connection

Total connected load 7.4 kW.

Connecting cable 1.5 m without plug.

Connecting cables 0.3 m and 1 m for control knobs.

Power consumption standby/display off 0.5 W.

Power consumption standby/network 2.0 W.

Please check the user manual for how to switch off the WiFi module.

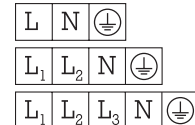

*Energy efficiency class: at a range of energy efficiency classes from A+++ to D.

Installation of the cooktop; flush mounting

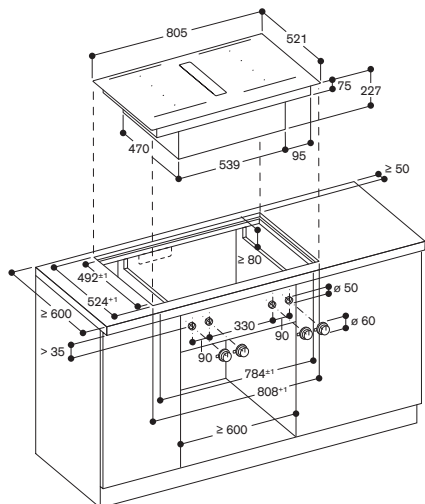

Measurements in mm

Installation of the control knob

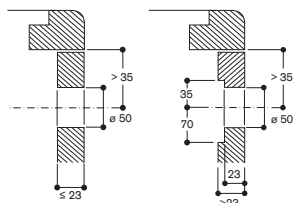

measurements in mm

View from above

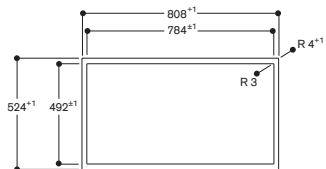

measurements in mm

Longitudinal section

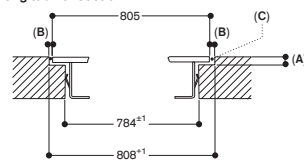

A: 6.5^{-0.5}
B: 1.5
C: Fill with silicone
measurements in mm

Cross-section

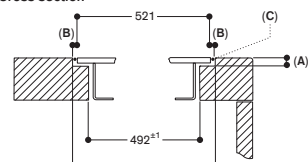

A: 6.5^{-0.5}
B: 1.5
C: Fill with silicone
measurements in mm

Front view

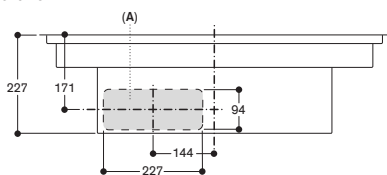

A: Connected directly at the rear
measurements in mm

Side view with unducted recirculation; flush mounting

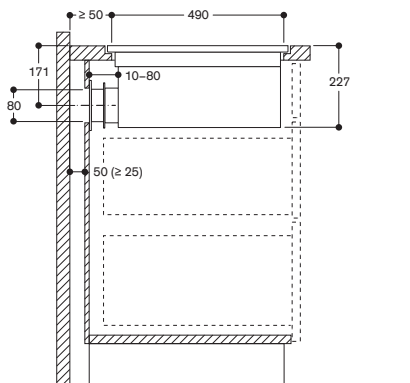

Not recommended for non-thermally insulated outer wall or floor (U ≥ 0.5 W/m²K)

Measurements in mm

Front view – furniture cut-out for unducted recirculation; flush mounting

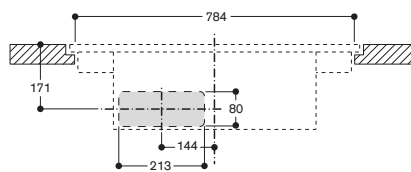

Measurements in mm

Front view of CV 482 with ducted recirculation

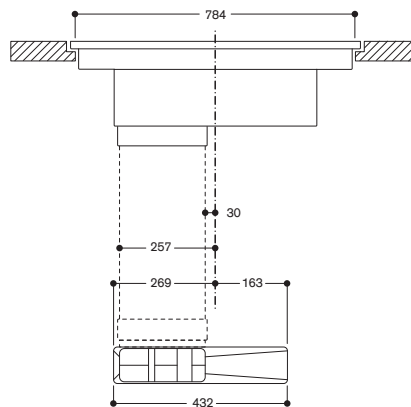

Measurements in mm

Side view with kit ducted air recirculation 700 mm worktop depth; flush mounting

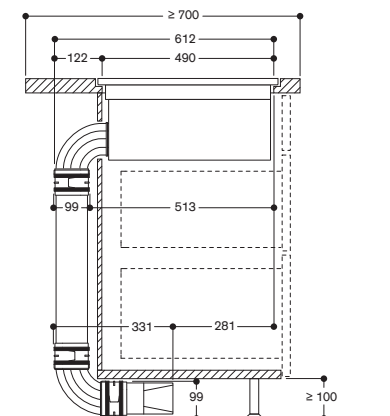

Not recommended for non-thermally insulated floor (U ≥ 0.5 W/m²K)

Measurements in mm

Side view with kit ducted air recirculation 600 mm worktop depth; flush mounting

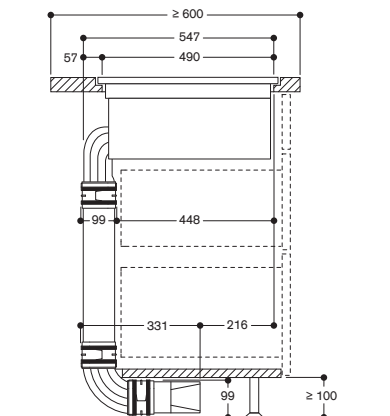

Not recommended for non-thermally insulated floor (U ≥ 0.5 W/m²K)

Measurements in mm



CV 282 101

Frameless
Width 80 cm
Air extraction / Air recirculation
Ducting needs to be ordered separately



Necessary installation accessories

CA 082 011
Kit unducted air recirculation
CA 082 061
Kit ducted air recirculation,
60 cm worktop depth
CA 082 071
Kit ducted air recirculation,
70 cm worktop depth
CA 084 010
4 acoustic filters for air extraction mode

Special accessories

CA 051 301
Teppan Yaki plate made of multi ply material
For flex induction cooktop.
CA 052 300
Griddle plate in cast aluminium
Non-stick.
For flex induction cooktop.
CA 050 300
Flex Pan set, 3 pcs.
Non-stick coating.
For flex induction cooktop.
CA 055 300
Flex Pan large
Non-stick coating.
For flex induction cooktop.
CA 060 300
Cooking sensor for temperature regulation within pots
CA 282 112
4 activated charcoal filters with highly efficient odour reduction and allergen deactivation.

Installation accessories for air ducting you will find at the pages 287 – 293.

Flex induction cooktop with integrated ventilation system 200 series CV 282

- Flex function for combining the rectangular cooking areas
- Free positioning of cookware inside combined cooking areas
- Highly efficient ventilation system integrated in the cooktop
- Fully automatic ventilation system functions
- Large-scale metal grease filter, easy to remove, dishwasher-safe
- Energy-saving, low-noise fan
- Air extraction or air recirculation system
- Integrated activated charcoal filter easily removeable from above for air recirculation system
- Twist-Pad control with removable, black magnetic knob
- Easy control of all functions with bicoloured display

Cooking zones

2 flex induction cooking areas 24x20cm (2200 W, with booster 3700 W), linked together 24x40 cm (3300 W, with booster 3700 W).
2 flex induction cooking areas 24x20 cm (2200 W, with booster 3700 W), linked together 24x40 cm (3300 W, with booster 3700 W).

Performance of ventilation system

Performance and noise level, output level 3/Intensive:
Air output according to EN 61591.
Sound power level according to EN 60704-3.
Odour reduction for air recirculation in accordance with EN 61591.
Air extraction:
532 / 636 m³/h.
70 / 74 dB (A) re 1 pW.
Air recirculation:
487 / 611 m³/h.
67 / 72 dB (A) re 1 pW.

Handling

Twist-Pad control with removable magnetic knob.
User friendly control with bicoloured display (white / orange).
Cooking zone and cooking area marking.
Electronic power control of the cooking zone in 17 output levels.
Control of ventilation system with 3 electronically controlled power levels and 1 intensive mode.

Features

Flex function for rectangular cooking areas.
Automatic pot detection when the cooktop is switched on.
Professional cooking function.
Cooking sensor function (in use with cooking sensor CA 060 300).
Frying sensor function.
Booster function for pots.
Booster function for pans.
Keep warm function.
Automatic sensor-controlled performance adjustment of the ventilation system.
Automatic activation of the ventilation system when a cooking zone is used.
Interval ventilation, 6 min.
Automatic sensor controlled or manual run on function.

Activated charcoal filter saturation indicator.
Removable, dishwasher-safe grease filter unit.
High-grade black zinc die-casted cover for ventilation system, dishwasher-safe.
Fan technology with highly efficient, brushless DC motor (BLDC).
Airflow-optimised interior for efficient air circulation.
Stopwatch.
Cooking timer for up to 99 minutes.
Short-term timer.
Memory function.
Options menu.
Power management.

Selected digital services (Home Connect)

Remote control and monitoring of ventilation.
Remote monitoring of cooking zones.
Remote diagnostics.

Please read additional information on Home Connect on page 411.

Consumption data

Energy efficiency class A at a range of energy efficiency classes from A+++ to D.
Energy consumption 56.9 kWh/year.
Ventilation efficiency class A.
Illumination efficiency class -.
Grease filter efficiency class B.
Sound level min. 61 dB / max. 70 dB normal mode.

Safety

Main switch.
Operation indicator.
Pot detection.
2-stage residual heat indication.
Child lock.
Safety shut-off.
Detachable, dishwasher-safe two-stage overflow protection.
Removable overflow container, 0,9-litre capacity, dishwasher-safe.

Planning notes

Bottom cabinet width: min. 60 cm.
Worktop depth: min. 60 cm.
The unducted recirculation set CA 082 011 requires a vertical aperture of min. 25 mm behind the backpanel of the furniture. Suggested for ideal performance are 50 mm.
The air outlet on the backside of the appliance can directly be accessed with a flat duct element (DN 150).
In air extraction mode a one-way flap with a maximum opening pressure of 65 Pa should be installed.
For optimum performance in air recirculation we recommend an outflow surface area of at least 440 cm².
Operates with magnetic (induction) iron pots and pans only. For an optimal heat distribution, the use of sandwich bottom cookware is recommended.

Special accessories

(please order as spare parts):
Part No. 17006018
Frying sensor pan, ø 20 cm
Part No. 17006184
Frying sensor pan, ø 24 cm

The equivalent ducting length to ensure good performance is L_{max} 28 m.
The appliance must be freely accessible from below.

Appliance must be fixed from underneath.
Appliance weight: approx. 27 kg.
When installing a ventilation hood with air extraction mode and a chimney-vented fireplace, the power supply line of the ventilation appliance needs a suitable safety switch.
Installation is possible in worktops made of stone, synthetics or solid wood. Heat resistance and watertight sealing of the cut edges must be observed. Concerning other materials please consult the worktop manufacturer.
The bearing capacity and stability, in the case of thin worktops in particular, must be supported using suitable substructures. Take into account the appliance weight and additional loads.
The groove must be continuous and even, so that uniform placing of the appliance on the gasket is ensured.
Do not use discontinuous lining.
Joint width may vary due to dimensional tolerances of the glass ceramic cooktop and the worktop cut-out.
Comply with the clearances from underneath the worktop to the overflow container: min. 300 mm to remove and empty the container.

Please read additional planning notes on page 188 – 189.

Connection

Total connected load 7.4 kW.
Connecting cable 1.5 m without plug.
Power consumption standby/
display off 0.5 W.
Power consumption standby/
network 2.0 W.
Please check the User manual for how to switch off the WiFi module.

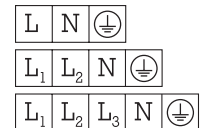

*Energy efficiency class: at a range of energy efficiency classes from A+++ to D.

Installation of the cooktop; flush mounting

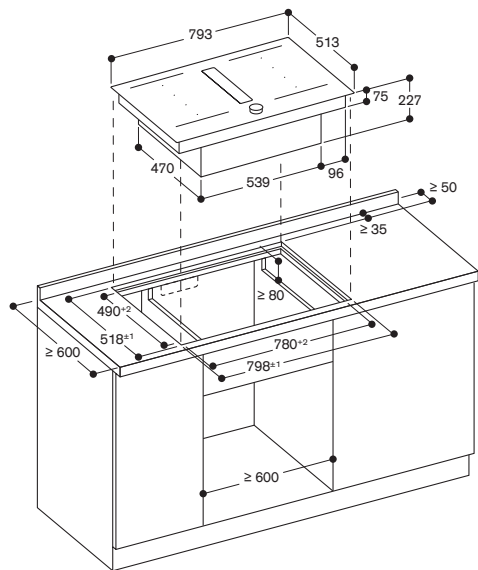

Measurements in mm

View from above

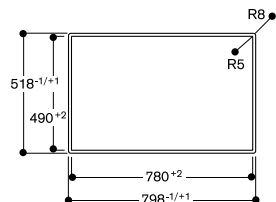

Longitudinal section

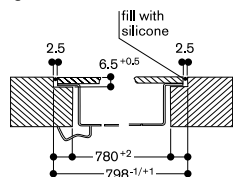

Cross section

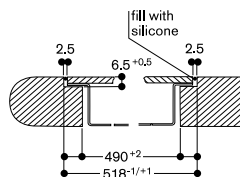

Front view

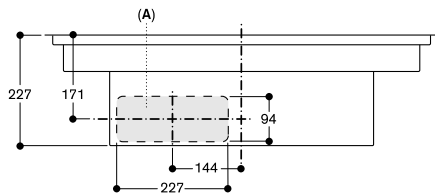

A: Connected directly at the rear

measurements in mm

Side view with unducted recirculation; flush mounting

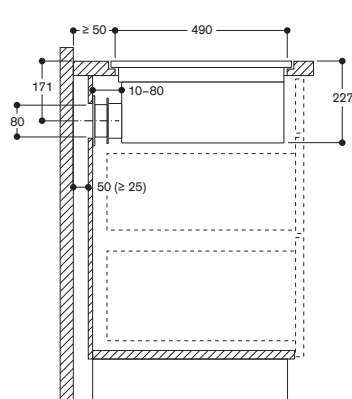

Not recommended for non-thermally insulated outer wall or floor ($U \geq 0.5 \text{ W/m}^2\text{K}$)

Measurements in mm

Front view - furniture cut-out for unducted recirculation flush mounting

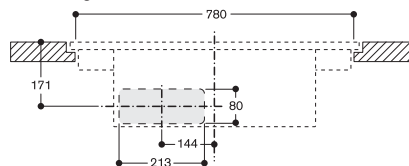

measurements in mm

Front view of CV 282 with ducted recirculation

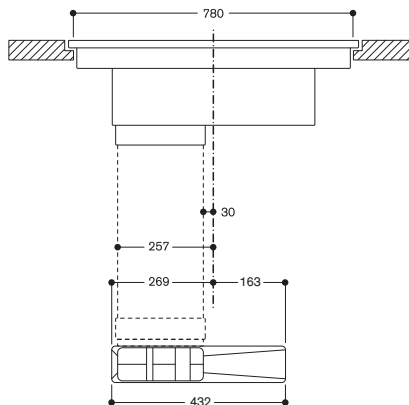

measurements in mm

Side view with kit ducted air recirculation 700 mm worktop depth; flush mounting

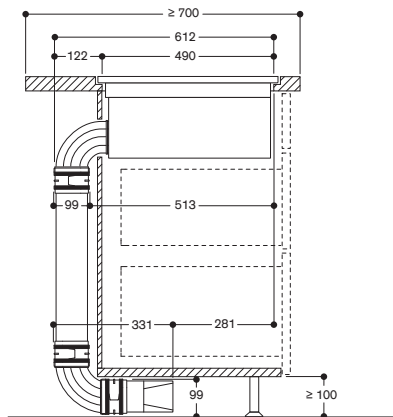

Not recommended for non-thermally insulated floor ($U \geq 0.5 \text{ W/m}^2\text{K}$)

Measurements in mm

Side view with kit ducted air recirculation 600 mm worktop depth; flush mounting

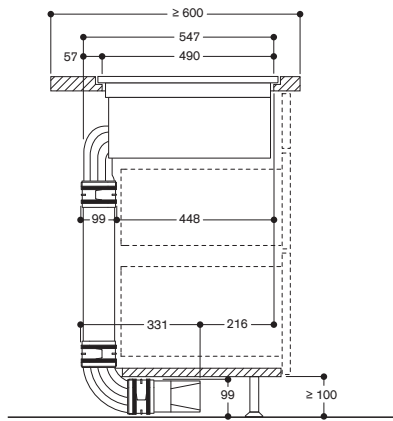

Not recommended for non-thermally insulated floor ($U \geq 0.5 \text{ W/m}^2\text{K}$)

Measurements in mm



CV 282 111

Stainless steel frame
Width 80 cm
Air extraction / Air recirculation
Ducting needs to be ordered separately



Necessary installation accessories

CA 082 011
Kit unducted air recirculation

CA 082 061
Kit ducted air recirculation,
60 cm worktop depth

CA 082 071
Kit ducted air recirculation,
70 cm worktop depth

CA 084 010
4 acoustic filters for air extraction mode

Special accessories

CA 051 301
Teppan Yaki plate made of multi ply material
For flex induction cooktop.

CA 052 300
Griddle plate in cast aluminium
Non-stick.
For flex induction cooktop.

CA 050 300
Flex Pan set, 3 pcs.
Non-stick coating.
For flex induction cooktop.

CA 055 300
Flex Pan large
Non-stick coating.
For flex induction cooktop.

CA 060 300
Cooking sensor for temperature regulation within pots

CA 230 1000
Black magnetic knob for induction cooktop 200 series
Stainless steel knob with black coating.

CA 282 112
4 activated charcoal filters with highly efficient odour reduction and allergen deactivation.

Installation accessories for air ducting you will find at the pages 287 – 293.

Flex induction cooktop with integrated ventilation system 200 series CV 282

- Sturdy stainless steel frame
- Flex function for combining the rectangular cooking areas
- Free positioning of cookware inside combined cooking areas
- Highly efficient ventilation system integrated in the cooktop
- Fully automatic ventilation system functions
- Large-scale metal grease filter, easy to remove, dishwasher-safe
- Energy-saving, low-noise fan
- Air extraction or air recirculation system
- Integrated activated charcoal filter easily removeable from above for air recirculation system
- Twist-Pad control with removable magnetic knob
- Easy control of all functions with bicoloured display

Cooking zones

2 flex induction cooking areas 23x19 cm (2200 W, with booster 3700 W), linked together 23x38 cm (3300 W, with booster 3700 W).

2 flex induction cooking areas 23x19 cm (2200 W, with booster 3700 W), linked together 23x38 cm (3300 W, with booster 3700 W).

Performance of ventilation system

Performance and noise level, output level 3/Intensive:
Air output according to EN 61591.
Sound power level according to EN 60704-3.
Odour reduction for air recirculation in accordance with EN 61591.
Air extraction:
532 / 636 m³/h.
70 / 74 dB (A) re 1 pW.
Air recirculation:
487 / 611 m³/h.
67 / 72 dB (A) re 1 pW.

Handling

Twist-Pad control with removable magnetic knob.
User friendly control with bicoloured display (white / orange).
Cooking zone and cooking area marking.
Electronic power control in 17 output levels.
Control of ventilation system with 3 electronically controlled power levels and 1 intensive mode.

Features

Flex function for rectangular cooking areas.
Automatic pot detection when the cooktop is switched on.
Professional cooking function.
Cooking sensor function (in use with cooking sensor CA 060 300).
Frying sensor function.
Booster function for pots.
Booster function for pans.
Keep warm function.
Automatic sensor-controlled performance adjustment of the ventilation system.
Automatic activation of the ventilation system when a cooking zone is used.
Interval ventilation, 6 min.
Automatic sensor controlled or manual run on function.

Activated charcoal filter saturation indicator.
Removable, dishwasher-safe grease filter unit.
High-grade black zinc die-casted cover for ventilation system, dishwasher-safe.
Fan technology with highly efficient, brushless DC motor (BLDC).
Airflow-optimised interior for efficient air circulation.
Stopwatch.
Cooking timer for up to 99 minutes.
Short-term timer.
Memory function.
Options menu.
Power management.

Selected digital services (Home Connect)

Remote control and monitoring of ventilation.
Remote monitoring of cooking zones.
Remote diagnostics.

Please read additional information on Home Connect on page 411.

Consumption data

Energy efficiency class A at a range of energy efficiency classes from A+++ to D.
Energy consumption 56.9 kWh/year.
Ventilation efficiency class A.
Illumination efficiency class -.
Grease filter efficiency class B.
Sound level min. 61 dB / max. 70 dB normal mode.

Safety

Main switch.
Operation indicator.
Pot detection.
2-stage residual heat indication.
Child lock.
Safety shut-off.
Detachable, dishwasher-safe two-stage overflow protection.
Removable overflow container, 0,9-litre capacity, dishwasher-safe.

Planning notes

Bottom cabinet width: min. 60 cm.
Worktop depth: min. 60 cm.
Immersion depth 223 mm.
The unducted recirculation set CA 082 011 requires a vertical aperture of min. 25 mm behind the backpanel of the furniture. Suggested for ideal performance are 50 mm.
The air outlet on the backside of the appliance can directly be accessed with a flat duct element (DN 150).
In air extraction mode a one-way flap with a maximum opening pressure of 65 Pa should be installed.
For optimum performance in air recirculation we recommend an outflow surface area of at least 440 cm².
Operates with magnetic (induction) iron pots and pans only. For an optimal heat distribution, the use of sandwich bottom cookware is recommended.

Special accessories (please order as spare parts):
Part No. 17006018
Frying sensor pan, ø 20 cm

The equivalent ducting length to ensure good performance is L_{max} 28 m.
The appliance must be freely accessible from below.

Appliance must be fixed from underneath.
Appliance weight: approx. 29 kg.
When installing a ventilation hood with air extraction mode and a chimney-vented fireplace, the power supply line of the ventilation appliance needs a suitable safety switch.
The bearing capacity and stability, in the case of thin worktops in particular, must be supported using suitable substructures. Take into account the appliance weight and additional loads.
Comply with the clearances from underneath the worktop to the overflow container: min. 300 mm to remove and empty the container.

Please read additional planning notes on page 188 – 189.

Connection

Total connected load 7.4 kW.
Connecting cable 1.5 m without plug.
Power consumption standby/display off 0.5 W.
Power consumption standby/network 2.0 W.
Please check the user manual for how to switch off the WiFi module.

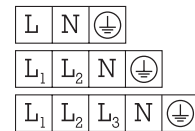

*Energy efficiency class: at a range of energy efficiency classes from A+++ to D.

Installation of the cooktop; surface mounting

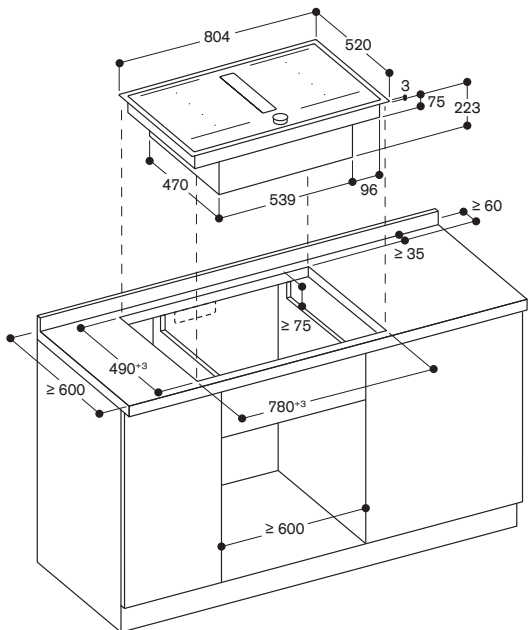

Measurements in mm

Front view

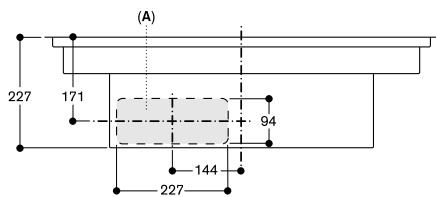

A: Connected directly at the rear
measurements in mm

Side view of CV 282 111 with unducted recirculation

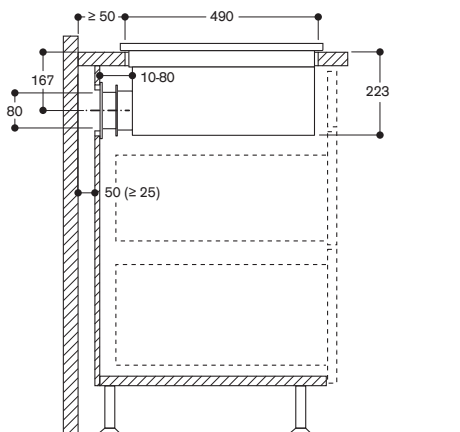

A: Not recommended for non-thermally insulated outer wall or floor ($U \geq 0.5 \text{ W/m}^2\text{K}$)
measurements in mm

Front view - furniture cut-out for unducted recirculation surface mounting

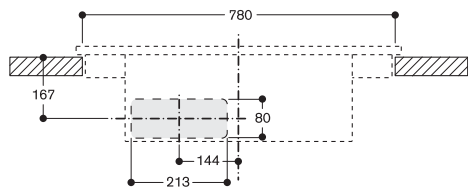

measurements in mm

Front view of CV 282 with ducted recirculation

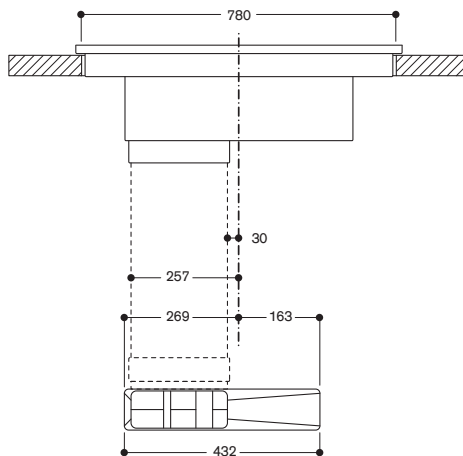

Measurements in mm

Side view with kit ducted air recirculation 700 mm worktop depth; surface mounting

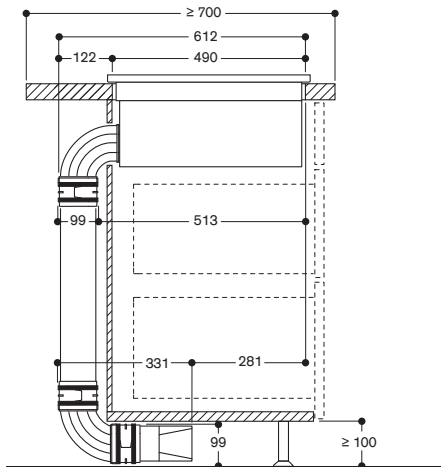

Not recommended for non-thermally insulated floor ($U \geq 0.5 \text{ W/m}^2\text{K}$)

Measurements in mm

Side view with kit ducted air recirculation 600 mm worktop depth; surface mounting

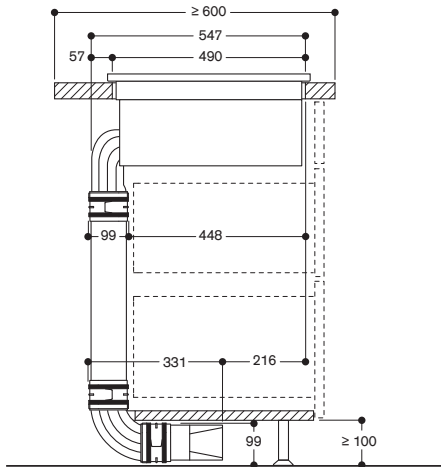

Not recommended for non-thermally insulated floor ($U \geq 0.5 \text{ W/m}^2\text{K}$)

Measurements in mm

Planning examples for flex induction cooktop with integrated ventilation system

Good to know – for correct planning and installation

- For depth measurements, take account of the depth of the furniture cavity and worktop overhangs of the kitchen furniture.
- The air extraction ducting can be connected to the rear. The respective connecting pieces are available for this purpose.
- The appliance must be accessible from underneath.

Air recirculation

- Installation with air recirculation kits
- Filters can be replaced from above.
- Allow accessibility from below.
- For optimum performance, the recirculated air requires sufficient space to escape (outflow surface area of at least 440 cm²).
- The unducted recirculation set CA 082 011 requires a vertical aperture of min. 25 mm behind the backpanel of the furniture. Suggested for ideal performance are 50 mm.

Planning example 1

CV 282 / CV 482 / CV 492 with unducted air recirculation

Wall installation, worktop depth 60 cm, Vertical aperture of min. 25 mm behind the backpanel of the furniture. Suggested for ideal performance are 50 mm.

Not recommended for non-thermally insulated outer wall or floor ($U \geq 0.5 \text{ W/m}^2\text{°C}$).

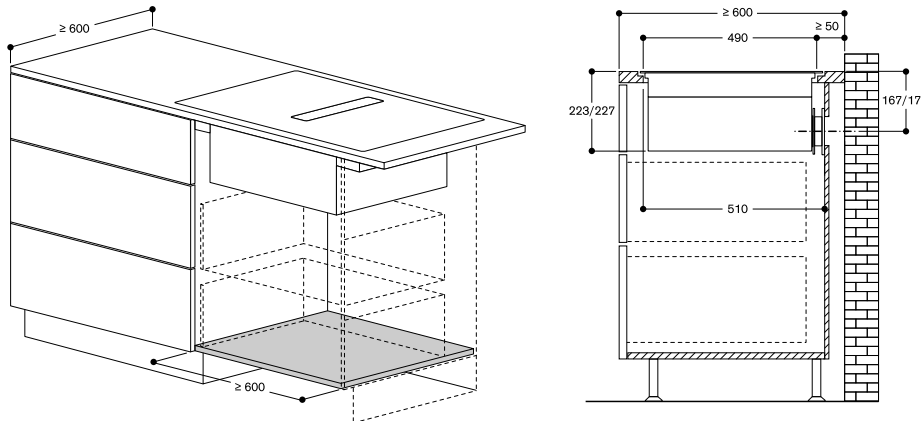

List of components:

- 1 x CA 082 011 Recirculation kit

Planning example 2

CV 282 / CV 482 / CV 492 with unducted air recirculation

Island installation, worktop depth 120 cm, Vertical aperture of min. 25 mm behind the back panel of the furniture. Suggested for ideal performance are 50 mm.

Not recommended for non-thermally insulated outer wall or floor ($U \geq 0.5 \text{ W/m}^2\text{°C}$).

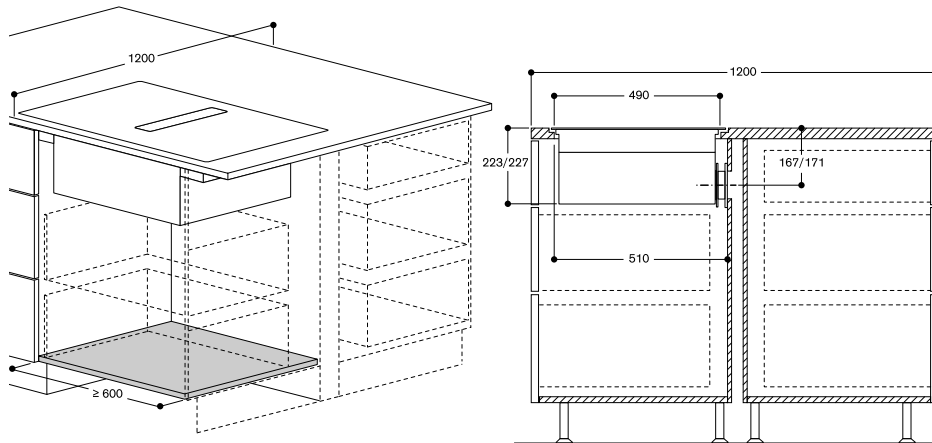

List of components:

- 1 x CA 082 011 Recirculation kit

Planning example 3

CV 282 / CV 482 / CV 492 with ducted recirculation

Island installation, worktop depth 90 cm

Not recommended for non-thermally insulated outer wall or floor ($U \geq 0.5 \text{ W/m}^2\text{°C}$).

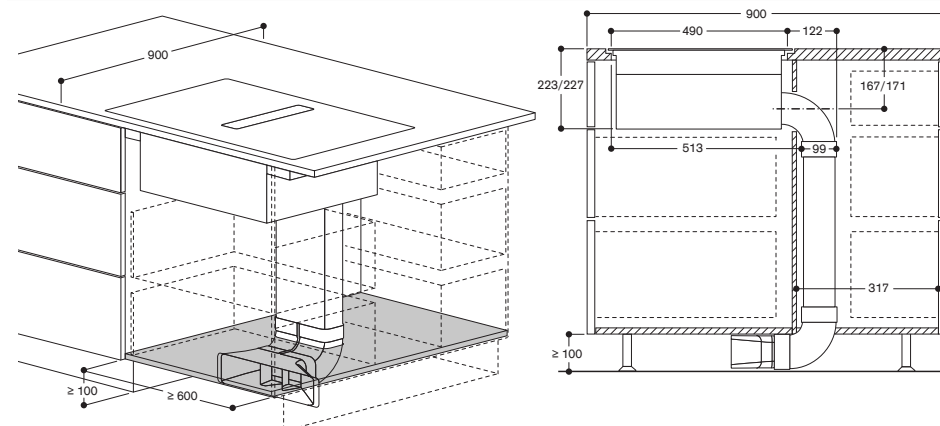

List of components:

- 1 x CA 082 071 Kit ducted air recirculation, 70 cm worktop depth

Air extraction

- Appliance is directly accessible with male flat duct DN 150.
- For all extraction installations please foresee acoustic filter (CA 084 010)
- Maximum length of the air extraction ducting system 8 m to assure good performance.
- For optimum air circulation, we recommend ducts with DN 150. Ducting and connection pieces are available as special accessories.
- Two flat ducts must be connected with a flat duct connecting piece.

Planning example 4**CV 282 / CV 482 / CV 492 with air extraction installation**

Wall installation, worktop depth 60 cm, direct connection to flat wall outlet.

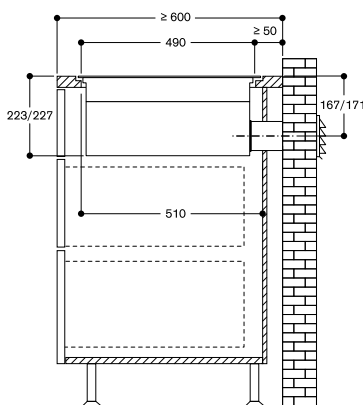
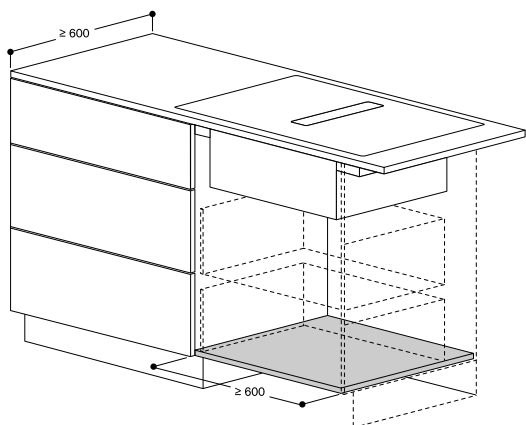
**List of components:**

- 1 x CA 084 010 Extraction kit
- 1 x AD 857 015 Flat duct DN 150 (0,5 meter)
- 1 x AD 850 050 Wall outlet DN150 flat

Planning example 5**CV 282 / CV 482 / CV 492 with air extraction installation**

Wall or island installation, worktop depth 70 cm, ducting directed to the outside via the cellar.

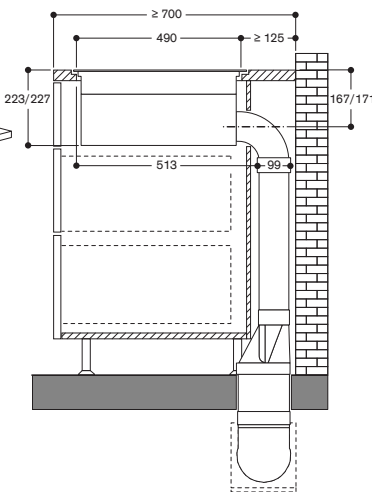
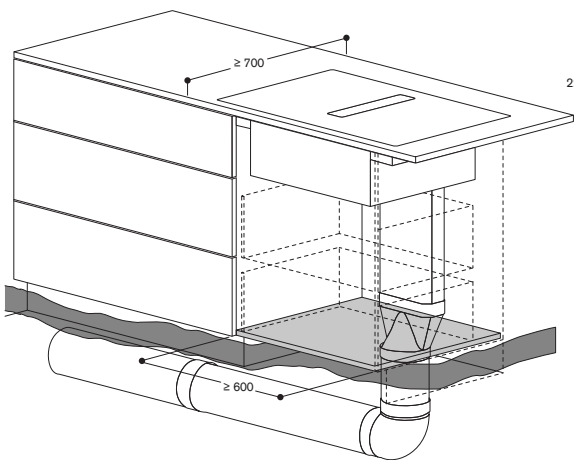
**List of components:**

- 1 x CA 084 010 Extraction kit
- 1 x AD 857 010 Flat duct DN 150 (1 meter)
- 1 x AD 857 030 Flat duct bend 90° vertical DN150 flat
- 1 x AD 857 041 Flat duct adapter round DN150 to DN150 flat
- 3 x AD 752 010 Round duct DN150
- 1 x AD 752 030 Duct bend 90° DN150
- 1 x AD 754 090 Pipe connector DN150
- 1 x AD 750 053 Wall outlet with telescopic duct DN150
- 1 x AD 990 090 Adhesive tape
- 2 x AD 857 040 Flat duct connecting piece

Planning example 6**CV 282 / CV 482 / CV 492 with air extraction installation**

Wall installation, worktop depth 65 cm, ducting behind the cabinet and in the plinth.

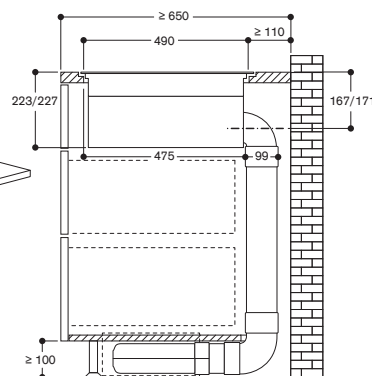
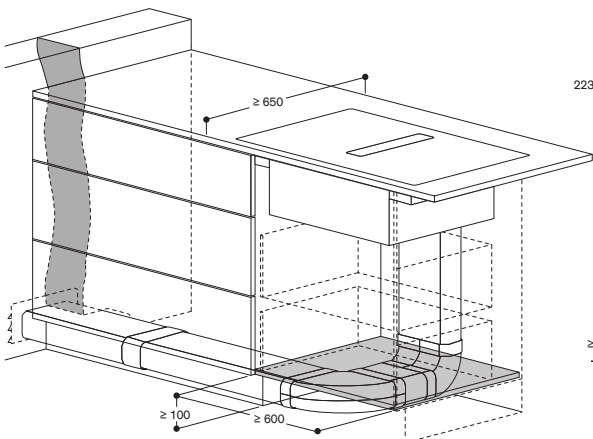
**List of components:**

- 1 x CA 084 010 Extraction kit
- 4 x AD 857 010 Flat duct DN 150 (1 meter)
- 1 x AD 857 030 Flat duct bend 90° vertical DN150 flat
- 1 x AD 857 031 Flat duct bend 90° horizontal
- 1 x AD 850 050 Wall outlet DN150 flat
- 1 x AD 857 033 Short flat duct bend 90° vertical DN150°
- 6 x AD 857 040 Flat duct connecting piece



CI 292 102

Frameless
Width 90 cm

Special accessories

CA 051 301

Teppan Yaki plate made of multi ply material

For flex induction cooktop.

CA 052 300

Griddle plate in cast aluminium
Non-stick.

For flex induction cooktop.

CA 050 300

Flex Pan set, 3 pcs.

Non-stick coating.

For flex induction cooktop.

CA 055 300

Flex Pan large

Non-stick coating.

For flex induction cooktop.

CA 230 100

Black magnetic knob for induction cooktop 200 series

Stainless steel knob with black coating.

Flex induction cooktop 200 series

CI 292

- Frameless for flush mounting
- Flex function for combining the rectangular cooking areas
- Free positioning of cookware inside combined cooking areas
- Professional cooking function for splitting the cooktop into predefined heat areas
- Cooking sensor function for temperature control in pots
- Frying sensor function for temperature control in pans
- Large cooking zone for pots up to $\varnothing 32$ cm
- Twist-Pad control with removable magnetic knob
- Easy control of all functions with bicoloured display

Cooking zones

2 flex induction cooking areas 23x20 cm (2200 W, with booster 3700 W), linked together 23x40 cm (3300 W, with booster 3700 W).

2 flex induction cooking areas 23x20 cm (2200 W, with booster 3700 W), linked together 23x40 cm (3300 W, with booster 3700 W).

1 induction cooking zone $\varnothing 21$ cm (2200 W, with booster 3700 W), automatically switches to $\varnothing 26$ cm (2600 W, with booster 3700 W) and to $\varnothing 32$ cm (3300 W, with booster 3700 W).

Handling

Twist-Pad control with removable magnetic knob.

User friendly control with bicoloured display (white / orange).

Cooking zone and cooking area marking.

Electronic power control in 17 output levels.

Features

Flex function for rectangular cooking areas.

Professional cooking function.

Cooking sensor function (in use with cooking sensor CA 060 300).

Frying sensor function.

Booster function for pots.

Booster function for pans.

Keep warm function.

Stopwatch.

Cooking timer for up to 99 minutes.

Short-term timer.

Options menu.

Power management.

Selected digital services

(Home Connect)

Cooktop-based ventilation control (with suitable hood).

Remote monitoring.

Remote diagnostics.

Please read additional information on Home Connect on page 411.

Safety

Main switch.

Operation indicator.

Pot detection.

2-stage residual heat indication.

Child lock.

Safety shut-off.

Planning notes

Installation is possible in worktops made of stone, synthetics or solid wood. Heat resistance and watertight sealing of the cut edges must be observed. Concerning other materials please consult the worktop manufacturer. The groove must be continuous and even, so that uniform placing of the appliance on the gasket is ensured. Do not use discontinuous lining. The joint width may vary due to size tolerances of the combinations and of the worktop cut-out. Operates with magnetic (induction) iron pots and pans only. For an optimal heat distribution, the use of sandwich bottom cookware is recommended.

Special accessories

(please order as spare parts):

Part No. 17006018

Frying sensor pan, $\varnothing 20$ cm

Part No. 17006184

Frying sensor pan, $\varnothing 24$ cm

Part No. 17006185

Frying sensor pan, $\varnothing 28$ cm

Part No. 17006019

Frying sensor pan, $\varnothing 32$ cm

The wok pan WP 400 001 cannot be used with this appliance.

Appliance must be fixed from underneath.

Appliance weight: approx. 27 kg.

Please read the installation details regarding air ducting on page 210.

Connection

Total connected load 11.1 kW.

Connecting cable 1.5 m without plug.

Power consumption standby/
display off 0.5 W.

Power consumption standby/
network 2.0 W.

Please check the user manual for how to switch off the WiFi module.

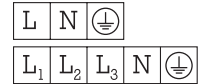



CI 292 112

Stainless steel frame
Width 90 cm

Special accessories

CA 051 301

Teppan Yaki plate made of multi ply material

For flex induction cooktop.

CA 052 300

Griddle plate in cast aluminium
Non-stick.

For flex induction cooktop.

CA 050 300

Flex Pan set, 3 pcs.

Non-stick coating.

For flex induction cooktop.

CA 055 300

Flex Pan large

Non-stick coating.

For flex induction cooktop.

CA 230 100

Black magnetic knob for induction cooktop 200 series

Stainless steel knob with black coating.

Flex induction cooktop 200 series

CI 292

- Sturdy stainless steel frame
- Flex function for combining the rectangular cooking areas
- Free positioning of cookware inside combined cooking areas
- Professional cooking function for splitting the cooktop into predefined heat areas
- Cooking sensor function for temperature control in pots
- Frying sensor function for temperature control in pans
- Large cooking zone for pots up to ø32 cm
- Twist-Pad control with removable magnetic knob
- Easy control of all functions with bicoloured display

Cooking zones

2 flex induction cooking areas 23x19 cm (2200 W, with booster 3700 W), linked together 23x38 cm (3300 W, with booster 3700 W).

2 flex induction cooking areas 23x19 cm (2200 W, with booster 3700 W), linked together 23x38 cm (3300 W, with booster 3700 W).

1 induction cooking zone ø21 cm (2200 W, with booster 3700 W), automatically switches to ø26 cm (2600 W, with booster 3700 W) and to ø32 cm (3300 W, with booster 3700 W).

Handling

Twist-Pad control with removable magnetic knob.

User friendly control with bicoloured display (white / orange).

Cooking zone and cooking area marking.

Electronic power control in 17 output levels.

Features

Flex function for rectangular cooking areas.

Professional cooking function.

Cooking sensor function (in use with cooking sensor CA 060 300).

Frying sensor function.

Booster function for pots.

Booster function for pans.

Keep warm function.

Stopwatch.

Cooking timer for up to 99 minutes.

Short-term timer.

Options menu.

Power management.

Selected digital services

(Home Connect)

Cooktop-based ventilation control (with suitable hood).

Remote monitoring.

Remote diagnostics.

Please read additional information on Home Connect on page 411.

Safety

Main switch.

Operation indicator.

Pot detection.

2-stage residual heat indication.

Child lock.

Safety shut-off.

Planning notes

Installation is possible in worktops made of stone, synthetics or solid wood. Heat resistance and watertight sealing of the cut edges must be observed. Concerning other materials please consult the worktop manufacturer. Operates with magnetic (induction) iron pots and pans only. For an optimal heat distribution, the use of sandwich bottom cookware is recommended.

Special accessories

(please order as spare parts):

Part No. 17006018

Frying sensor pan, ø20 cm

Part No. 17006184

Frying sensor pan, ø24 cm

Part No. 17006185

Frying sensor pan, ø28 cm

Part No. 17006019

Frying sensor pan, ø32 cm

The wok pan WP 400 001 cannot be used with this appliance.

Appliance must be fixed from underneath.

Appliance weight: approx. 23 kg.

Please read the installation details regarding air ducting on page 210.

Connection

Total connected load 11.1 kW.

Connecting cable 1.5 m without plug.

Power consumption standby/
display off 0.5 W.

Power consumption standby/
network 2.0 W.

Please check the user manual for how to switch off the WiFi module.

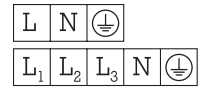

Installation of the cooktop; surface mounting

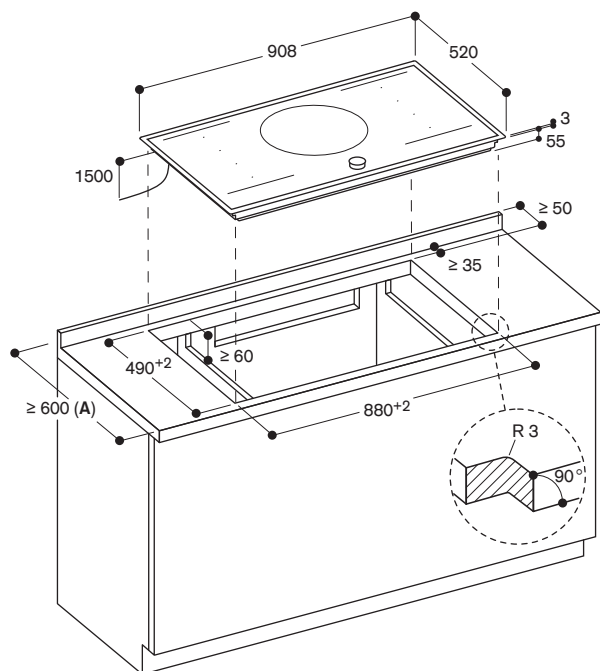

A: Please check the installation manual in case the worktop depth is below 600 mm.

measurements in mm



CI 283 103

Frameless
Width 80 cm

Special accessories

CA 051 301

Teppan Yaki plate made of multi ply material
For flex induction cooktop.

CA 052 300

Griddle plate in cast aluminium
Non-stick.
For flex induction cooktop.

CA 050 300

Flex Pan set, 3 pcs.

Non-stick coating.
For flex induction cooktop.

CA 055 300

Flex Pan large
Non-stick coating.
For flex induction cooktop.

CA 230 100

Black magnetic knob for induction cooktop 200 series
Stainless steel knob with black coating.

Flex induction cooktop 200 series

CI 283

- Frameless for flush mounting
- Flex function for combining the rectangular cooking areas
- Free positioning of cookware inside combined cooking areas
- Professional cooking function for splitting the cooktop into predefined heat areas
- Cooking sensor function for temperature control in pots
- Frying sensor function for temperature control in pans
- Twist-Pad control with removable magnetic knob
- Easy control of all functions with bicoloured display

Cooking zones

2 flex induction cooking areas 21x20 cm (2200 W, with booster 3700 W), linked together 21x40 cm (3300 W, with booster 3700 W).

1 induction cooking zone ø 24 cm (2200 W, with booster 3700 W).

1 induction cooking zone ø 18 cm (1800 W, with booster 3100 W).

1 induction cooking zone ø 15 cm (1400 W, with booster 2200 W).

Handling

Twist-Pad control with removable magnetic knob.

User friendly control with bicoloured display (white / orange).

Cooking zone and cooking area marking.
Electronic power control in 17 output levels.

Features

Flex function for rectangular cooking areas.

Professional cooking function.

Cooking sensor function (in use with cooking sensor CA 060 300).

Frying sensor function.

Booster function for pots.

Booster function for pans.

Keep warm function.

Stopwatch.

Cooking timer for up to 99 minutes.

Short-term timer.

Options menu.

Power management.

Selected digital services

(Home Connect)

Cooktop-based ventilation control (with suitable hood).

Remote monitoring.

Remote diagnostics.

Please read additional information on Home Connect on page 411.

Safety

Main switch.

Operation indicator.

Pot detection.

2-stage residual heat indication.

Child lock.

Safety shut-off.

Planning notes

Installation is possible in worktops made of stone, synthetics or solid wood. Heat resistance and watertight sealing of the cut edges must be observed. Concerning other materials please consult the worktop manufacturer. The groove must be continuous and even, so that uniform placing of the appliance on the gasket is ensured. Do not use discontinuous lining. The joint width may vary due to size tolerances of the combinations and of the worktop cut-out. Operates with magnetic (induction) iron pots and pans only. For an optimal heat distribution, the use of sandwich bottom cookware is recommended.

Special accessories

(please order as spare parts):

Part No. 17006018

Frying sensor pan, ø 20 cm

Part No. 17006184

Frying sensor pan, ø 24 cm

The wok pan WP 400 001 cannot be used with this appliance.

Appliance must be fixed from underneath.

Appliance weight: approx. 16 kg.

Please read the installation details regarding air ducting on page 210.

Connection

Total connected load 7.4 kW.

Connecting cable 1.5 m without plug.

Power consumption standby/ display off 0.5 W.

Power consumption standby/ network 2.0 W.

Please check the user manual for how to switch off the WiFi module.

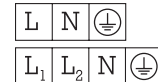



CI 283 113

Stainless steel frame
Width 80 cm

Special accessories

CA 051 301

Teppan Yaki plate made of multi ply material
For flex induction cooktop.

CA 052 300

Griddle plate in cast aluminium
Non-stick.
For flex induction cooktop.

CA 050 300

Flex Pan set, 3 pcs.

Non-stick coating.
For flex induction cooktop.

CA 055 300

Flex Pan large
Non-stick coating.
For flex induction cooktop.

CA 230 100

Black magnetic knob for induction cooktop 200 series
Stainless steel knob with black coating.

Flex induction cooktop 200 series

CI 283

- Sturdy stainless steel frame
- Flex function for combining the rectangular cooking areas
- Free positioning of cookware inside combined cooking areas
- Professional cooking function for splitting the cooktop into predefined heat areas
- Cooking sensor function for temperature control in pots
- Frying sensor function for temperature control in pans
- Twist-Pad control with removable magnetic knob
- Easy control of all functions with bicoloured display

Cooking zones

2 flex induction cooking areas 21x19 cm (2200 W, with booster 3700 W), linked together 21x38 cm (3300 W, with booster 3700 W).

1 induction cooking zone ø 24 cm (2200 W, with booster 3700 W).

1 induction cooking zone ø 18 cm (1800 W, with booster 3100 W).

1 induction cooking zone ø 15 cm (1400 W, with booster 2200 W).

Handling

Twist-Pad control with removable magnetic knob.

User friendly control with bicoloured display (white / orange).

Cooking zone and cooking area marking.
Electronic power control in 17 output levels.

Features

Flex function for rectangular cooking areas.

Professional cooking function.

Cooking sensor function (in use with cooking sensor CA 060 300).

Frying sensor function.

Booster function for pots.

Booster function for pans.

Keep warm function.

Stopwatch.

Cooking timer for up to 99 minutes.

Short-term timer.

Options menu.

Power management.

Selected digital services

(Home Connect)

Cooktop-based ventilation control (with suitable hood).

Remote monitoring.

Remote diagnostics.

Please read additional information on Home Connect on page 411.

Safety

Main switch.

Operation indicator.

Pot detection.

2-stage residual heat indication.

Child lock.

Safety shut-off.

Planning notes

Installation is possible in worktops made of stone, synthetics or solid wood. Heat resistance and watertight sealing of the cut edges must be observed. Concerning other materials please consult the worktop manufacturer. Operates with magnetic (induction) iron pots and pans only. For an optimal heat distribution, the use of sandwich bottom cookware is recommended.

Special accessories

(please order as spare parts):

Part No. 17006018

Frying sensor pan, ø 20 cm

Part No. 17006184

Frying sensor pan, ø 24 cm

The wok pan WP 400 001 cannot be used with this appliance.

Appliance must be fixed from underneath.

Appliance weight: approx. 17 kg.

Please read the installation details regarding air ducting on page 210.

Connection

Total connected load 7.4 kW.

Connecting cable 1.5 m without plug.

Power consumption standby/display off 0.5 W.

Power consumption standby/network 2.0 W.

Please check the user manual for how to switch off the WiFi module.

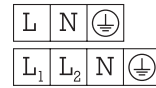

Installation of the cooktop; surface mounting

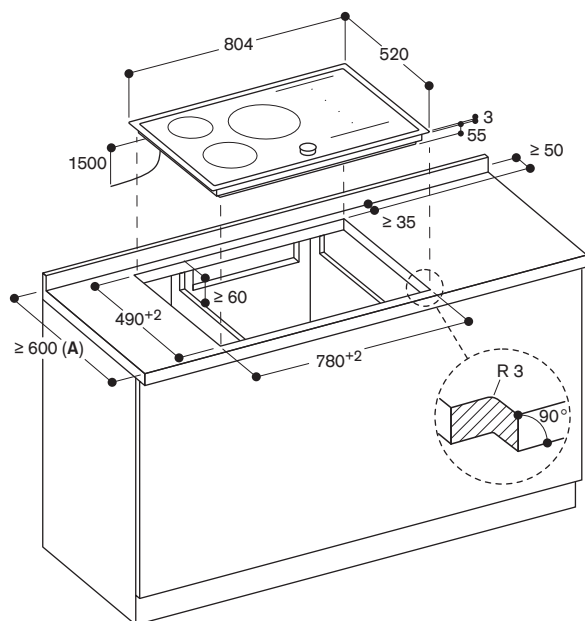

A: Please check the installation manual in case the worktop depth is below 600 mm.

measurements in mm



CI 282 102

Frameless
Width 80 cm

Special accessories

CA 051 301

Teppan Yaki plate made of multi ply material

For flex induction cooktop.

CA 052 300

Griddle plate in cast aluminium
Non-stick.

For flex induction cooktop.

CA 050 300

Flex Pan set, 3 pcs.

Non-stick coating.

For flex induction cooktop.

CA 055 300

Flex Pan large

Non-stick coating.

For flex induction cooktop.

CA 230 100

Black magnetic knob for induction cooktop 200 series

Stainless steel knob with black coating.

Flex induction cooktop 200 series

CI 282

- Frameless for flush mounting
- Flex function for combining the rectangular cooking areas
- Free positioning of cookware inside combined cooking areas with automatic extension up to 30 cm width
- Cooking sensor function for temperature control in pots
- Professional cooking function for splitting the cooktop into predefined heat areas
- Frying sensor function for temperature control in pans
- Twist-Pad control with removable magnetic knob
- Easy control of all functions with bicoloured display

Cooking zones

2 flex induction cooking areas 23x20 cm (2200 W, with booster 3700 W), linked together 23x40 cm (3300 W, with booster 3700 W), with automatic extension up to 30x30 cm (3300 W, with booster 3700 W).

2 flex induction cooking areas 23x20 cm (2200 W, with booster 3700 W), linked together 23x40 cm (3300 W, with booster 3700 W), with automatic extension up to 30x30 cm (3300 W, with booster 3700 W).

Handling

Twist-Pad control with removable magnetic knob.

User friendly control with bicoloured display (white / orange).

Cooking zone and cooking area marking.

Electronic power control in 17 output levels.

Features

Flex function for rectangular cooking areas.

Professional cooking function.

Cooking sensor function (in use with cooking sensor CA 060 300).

Frying sensor function.

Booster function for pots.

Booster function for pans.

Keep warm function.

Stopwatch.

Cooking timer for up to 99 minutes.

Short-term timer.

Options menu.

Power management.

Selected digital services

(Home Connect)

Cooktop-based ventilation control (with suitable hood).

Remote monitoring.

Remote diagnostics.

Please read additional information on Home Connect on page 411.

Safety

Main switch.

Operation indicator.

Pot detection.

2-stage residual heat indication.

Child lock.

Safety shut-off.

Planning notes

Installation is possible in worktops made of stone, synthetics or solid wood. Heat resistance and watertight sealing of the cut edges must be observed. Concerning other materials please consult the worktop manufacturer. Operates with magnetic (induction) iron pots and pans only. For an optimal heat distribution, the use of sandwich bottom cookware is recommended.

Special accessories

(please order as spare parts):

Part No. 17006018

Frying sensor pan, ø 20 cm

Part No. 17006184

Frying sensor pan, ø 24 cm

Part No. 17006185

Frying sensor pan, ø 28 cm

The wok pan WP 400001 cannot be used with this appliance.

Appliance must be fixed from underneath.

Appliance weight: approx. 18 kg.

Please read the installation details regarding air ducting on page 210.

Connection

Total connected load 7.4 kW.

Connecting cable 1.5 m without plug.

Power consumption standby/display off 0.5 W.

Power consumption standby/network 2.0 W.

Please check the user manual for how to switch off the WiFi module.

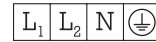

Installation of the cooktop; flush mounting

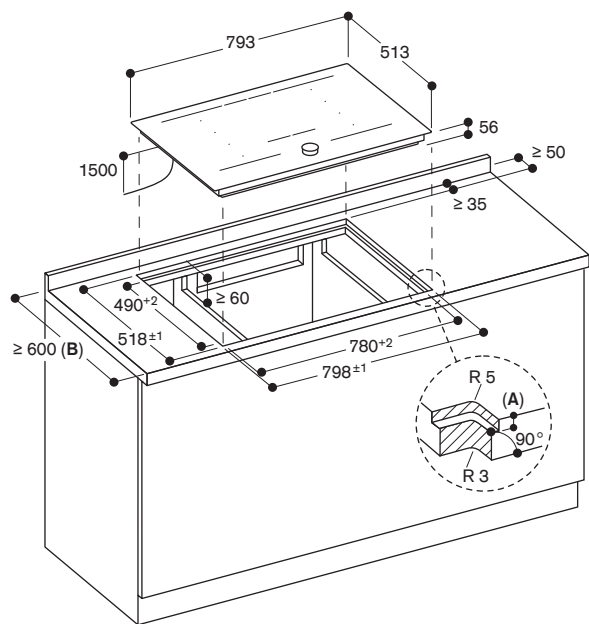

A: $6.5^{+0.5}$
 B: Please check the installation manual in case the worktop depth is below 600 mm.

measurements in mm

View from above

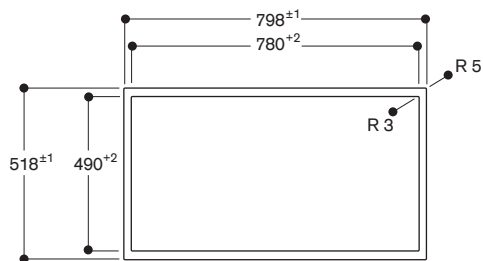

measurements in mm

Longitudinal section

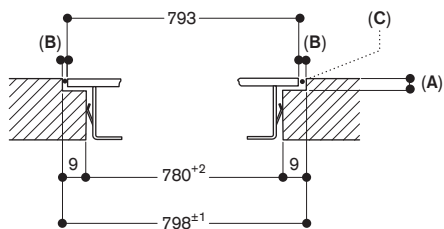

A: $6.5^{+0.5}$
 B: 2.5
 C: Fill with silicone

measurements in mm

Cross-section

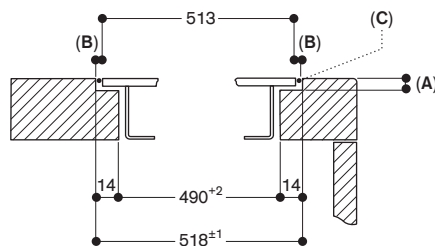

A: $6.5^{+0.5}$
 B: 2.5
 C: Fill with silicone

measurements in mm



CI 282 112

Stainless steel frame
Width 80 cm

Special accessories

CA 051 301

Teppan Yaki plate made of multi ply material
For flex induction cooktop.

CA 052 300

Griddle plate in cast aluminium
Non-stick.
For flex induction cooktop.

CA 050 300

Flex Pan set, 3 pcs.
Non-stick coating.
For flex induction cooktop.

CA 055 300

Flex Pan large
Non-stick coating.
For flex induction cooktop.

CA 230 100

Black magnetic knob for induction cooktop 200 series
Stainless steel knob with black coating.

Flex induction cooktop 200 series

CI 282

- Sturdy stainless steel frame
- Flex function for combining the rectangular cooking areas
- Free positioning of cookware inside combined cooking areas with automatic extension up to 30 cm width
- Cooking sensor function for temperature control in pots
- Professional cooking function for splitting the cooktop into predefined heat areas
- Frying sensor function for temperature control in pans
- Twist-Pad control with removable magnetic knob
- Easy control of all functions with bicoloured display

Cooking zones

2 flex induction cooking areas 22,5x19 cm (2200 W, with booster 3700 W), linked together 22,5x38 cm (3300 W, with booster 3700 W), with automatic extension up to 30x30 cm (3300 W, with booster 3700 W).

2 flex induction cooking areas 22,5x19 cm (2200 W, with booster 3700 W), linked together 22,5x38 cm (3300 W, with booster 3700 W), with automatic extension up to 30x30 cm (3300 W, with booster 3700 W).

Handling

Twist-Pad control with removable magnetic knob.

User friendly control with bicoloured display (white / orange).

Cooking zone and cooking area marking.

Electronic power control in 17 output levels.

Features

Flex function for rectangular cooking areas.

Professional cooking function.

Cooking sensor function (in use with cooking sensor CA 060 300).

Frying sensor function.

Booster function for pots.

Booster function for pans.

Keep warm function.

Stopwatch.

Cooking timer for up to 99 minutes.

Short-term timer.

Options menu.

Power management.

Selected digital services

(Home Connect)

Cooktop-based ventilation control (with suitable hood).

Remote monitoring.

Remote diagnostics.

Please read additional information on Home Connect on page 411.

Safety

Main switch.

Operation indicator.

Pot detection.

2-stage residual heat indication.

Child lock.

Safety shut-off.

Planning notes

Installation is possible in worktops made of stone, synthetics or solid wood. Heat resistance and watertight sealing of the cut edges must be observed. Concerning other materials please consult the worktop manufacturer. Operates with magnetic (induction) iron pots and pans only. For an optimal heat distribution, the use of sandwich bottom cookware is recommended.

Special accessories

(please order as spare parts):
Part No. 17006018

Frying sensor pan, ø 20 cm

Part No. 17006184

Frying sensor pan, ø 24 cm

Part No. 17006185

Frying sensor pan, ø 28 cm

The wok pan WP 400001 cannot be used with this appliance.

Appliance must be fixed from underneath.

Appliance weight: approx. 17 kg.

Please read the installation details regarding air ducting on page 210.

Connection

Total connected load 7.4 kW.

Connecting cable 1.5 m without plug.

Power consumption standby/display off 0.5 W.

Power consumption standby/network 2.0 W.

Please check the user manual for how to switch off the WiFi module.

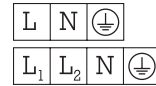

Installation of the cooktop; surface mounting

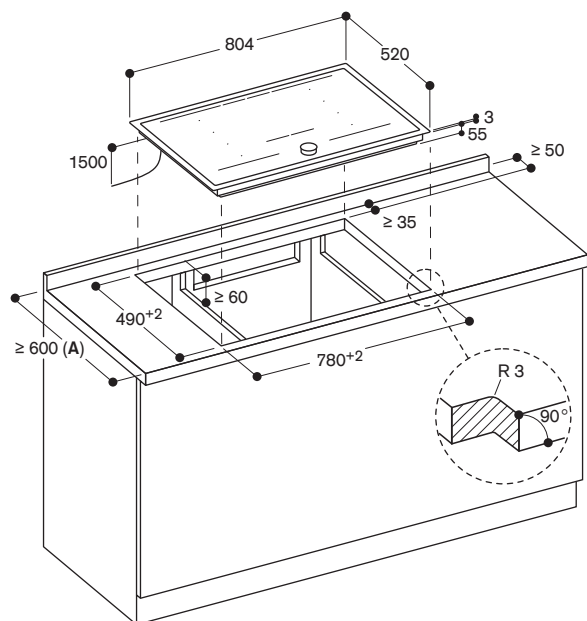

A: Please check the installation manual in case the worktop depth is below 600 mm.

measurements in mm



CI 272 103

Frameless
Width 70 cm

Special accessories

CA 051 301

Teppan Yaki plate made of multi ply material

For flex induction cooktop.

CA 052 300

Griddle plate in cast aluminium
Non-stick.

For flex induction cooktop.

CA 050 300

Flex Pan set, 3 pcs.
Non-stick coating.

For flex induction cooktop.

CA 055 300

Flex Pan large
Non-stick coating.

For flex induction cooktop.

CA 230 100

Black magnetic knob for induction cooktop 200 series

Stainless steel knob with black coating.

Flex induction cooktop 200 series

CI 272

- Frameless for flush mounting
- Flex function for combining the rectangular cooking areas
- Free positioning of cookware inside combined cooking areas with automatic extension up to 30 cm width
- Cooking sensor function for temperature control in pots
- Professional cooking function for splitting the cooktop into predefined heat areas
- Frying sensor function for temperature control in pans
- Twist-Pad control with removable magnetic knob
- Easy control of all functions with bicoloured display

Cooking zones

2 flex induction cooking areas 23x19 cm (2200 W, with booster 3700 W), linked together 23x38 cm (3300 W, with booster 3700 W), with automatic extension up to 30x30 cm (3300 W, with booster 3700 W).

2 flex induction cooking areas 23x19 cm (2200 W, with booster 3700 W), linked together 23x38 cm (3300 W, with booster 3700 W), with automatic extension up to 30x30 cm (3300 W, with booster 3700 W).

Handling

Twist-Pad control with removable magnetic knob.

User friendly control with bicoloured display (white / orange).

Cooking zone and cooking area marking.

Electronic power control in 17 output levels.

Features

Flex function for rectangular cooking areas.

Professional cooking function.

Cooking sensor function (in use with cooking sensor CA 060 300).

Frying sensor function.

Booster function for pots.

Booster function for pans.

Keep warm function.

Stopwatch.

Cooking timer for up to 99 minutes.

Short-term timer.

Options menu.

Power management

Selected digital services

(Home Connect)

Cooktop-based ventilation control (with suitable hood).

Remote monitoring.

Remote diagnostics.

Please read additional information on Home Connect on page 411.

Safety

Main switch.

Operation indicator.

Pot detection.

2-stage residual heat indication.

Child lock.

Safety shut-off.

Planning notes

Installation is possible in worktops made of stone, synthetics or solid wood. Heat resistance and watertight sealing of the cut edges must be observed. Concerning other materials please consult the worktop manufacturer. Operates with magnetic (induction) iron pots and pans only. For an optimal heat distribution, the use of sandwich bottom cookware is recommended.

Special accessories

(please order as spare parts):

Part No. 17006018

Frying sensor pan, ø 20 cm

Part No. 17006184

Frying sensor pan, ø 24 cm

Part No. 17006185

Frying sensor pan, ø 28 cm

The wok pan WP 400001 cannot be used with this appliance.

Appliance must be fixed from underneath.

Appliance weight: approx. 16 kg.

Please read the installation details regarding air ducting on page 210.

Connection

Total connected load 7.4 kW.

Connecting cable 1.5 m without plug.

Power consumption standby/ display off 0.5 W.

Power consumption standby/ network 2.0 W.

Please check the user manual for how to switch off the WiFi module.

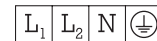



CI 272 113

Stainless steel frame

Width 70 cm

Special accessories

CA 051 301

Teppan Yaki plate made of multi ply material

For flex induction cooktop.

CA 052 300

Griddle plate in cast aluminium
Non-stick.

For flex induction cooktop.

CA 050 300

Flex Pan set, 3 pcs.

Non-stick coating.

For flex induction cooktop.

CA 055 300

Flex Pan large

Non-stick coating.

For flex induction cooktop.

CA 230 100

Black magnetic knob for induction cooktop 200 series

Stainless steel knob with black coating.

Flex induction cooktop 200 series

CI 272

- Sturdy stainless steel frame
- Flex function for combining the rectangular cooking areas
- Free positioning of cookware inside combined cooking areas with automatic extension up to 30 cm width
- Cooking sensor function for temperature control in pots
- Professional cooking function for splitting the cooktop into predefined heat areas
- Frying sensor function for temperature control in pans
- Twist-Pad control with removable magnetic knob
- Easy control of all functions with bicoloured display

Cooking zones

2 flex induction cooking areas 22,5x19 cm (2200 W, with booster 3700 W), linked together 22,5x38 cm (3300 W, with booster 3700 W), with automatic extension up to 30x30 cm (3300 W, with booster 3700 W).

2 flex induction cooking areas 22,5x19 cm (2200 W, with booster 3700 W), linked together 22,5x38 cm (3300 W, with booster 3700 W), with automatic extension up to 30x30 cm (3300 W, with booster 3700 W).

Handling

Twist-Pad control with removable magnetic knob.

User friendly control with bicoloured display (white / orange).

Cooking zone and cooking area marking.

Electronic power control in 17 output levels.

Features

Flex function for rectangular cooking areas.

Professional cooking function.

Cooking sensor function (in use with cooking sensor CA 060 300).

Frying sensor function.

Booster function for pots.

Booster function for pans.

Keep warm function.

Stopwatch.

Cooking timer for up to 99 minutes.

Short-term timer.

Options menu.

Power management.

Selected digital services

(Home Connect)

Cooktop-based ventilation control (with suitable hood).

Remote monitoring.

Remote diagnostics.

Please read additional information on Home Connect on page 411.

Safety

Main switch.

Operation indicator.

Pot detection.

2-stage residual heat indication.

Child lock.

Safety shut-off.

Planning notes

Installation is possible in worktops made of stone, synthetics or solid wood. Heat resistance and watertight sealing of the cut edges must be observed. Concerning other materials please consult the worktop manufacturer. Operates with magnetic (induction) iron pots and pans only. For an optimal heat distribution, the use of sandwich bottom cookware is recommended.

Special accessories

(please order as spare parts):

Part No. 17006018

Frying sensor pan, ø 20 cm

Part No. 17006184

Frying sensor pan, ø 24 cm

Part No. 17006185

Frying sensor pan, ø 28 cm

The wok pan WP 400001 cannot be used with this appliance.

Appliance must be fixed from underneath.

Appliance weight: approx. 17 kg.

Please read the installation details regarding air ducting on page 210.

Connection

Total connected load 7.4 kW.

Connecting cable 1.5 m without plug.

Power consumption standby/ display off 0.5 W.

Power consumption standby/ network 2.0 W.

Please check the user manual for how to switch off the WiFi module.

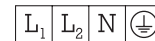

Installation of the cooktop; surface mounting

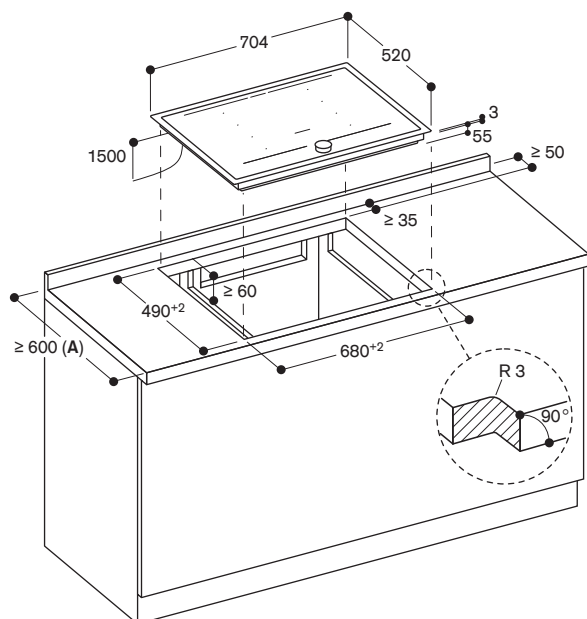

A: Please check the installation manual in case the worktop depth is below 600 mm.

measurements in mm



CI 262 105
 Frameless
 Width 60 cm

Special accessories

CA 051 301
 Teppan Yaki plate made of multi ply material
 For flex induction cooktop.

CA 052 300
 Griddle plate in cast aluminium
 Non-stick.
 For flex induction cooktop.

CA 050 300
 Flex Pan set, 3 pcs.
 Non-stick coating.
 For flex induction cooktop.

CA 055 300
 Flex Pan large
 Non-stick coating.
 For flex induction cooktop.

CA 230 100
 Black magnetic knob for induction cooktop 200 series
 Stainless steel knob with black coating.

Flex induction cooktop 200 series
CI 262

- Frameless for flush mounting
- Flex function for combining the rectangular cooking areas
- Free positioning of cookware inside combined cooking areas with automatic extension up to 30 cm width
- Cooking sensor function for temperature control in pots
- Professional cooking function for splitting the cooktop into predefined heat areas
- Frying sensor function for temperature control in pans
- Twist-Pad control with removable magnetic knob
- Easy control of all functions with bicoloured display

Cooking zones

2 flex induction cooking areas 23x19 cm (2200 W, with booster 3700 W), linked together 23x38 cm (3300 W, with booster 3700 W), with automatic extension up to 30x30 cm (3300 W, with booster 3700 W).
 2 flex induction cooking areas 23x19 cm (2200 W, with booster 3700 W), linked together 23x38 cm (3300 W, with booster 3700 W), with automatic extension up to 30x30 cm (3300 W, with booster 3700 W).

Handling

Twist-Pad control with removable magnetic knob.
 User friendly control with bicoloured display (white / orange).
 Cooking zone and cooking area marking.
 Electronic power control in 17 output levels.

Features

Flex function for rectangular cooking areas.
 Professional cooking function.
 Cooking sensor function (in use with cooking sensor CA 060 300).
 Frying sensor function.
 Booster function for pots.
 Booster function for pans.
 Keep warm function.
 Stopwatch.
 Cooking timer for up to 99 minutes.
 Short-term timer.
 Options menu.
 Power management.

Selected digital services
(Home Connect)

Cooktop-based ventilation control (with suitable hood).
 Remote monitoring.
 Remote diagnostics.

Please read additional information on Home Connect on page 411.

Safety

Main switch.
 Operation indicator.
 Pot detection.
 2-stage residual heat indication.
 Child lock.
 Safety shut-off.

Planning notes

Installation is possible in worktops made of stone, synthetics or solid wood. Heat resistance and watertight sealing of the cut edges must be observed. Concerning other materials please consult the worktop manufacturer. The groove must be continuous and even, so that uniform placing of the appliance on the gasket is ensured. Do not use discontinuous lining. The joint width may vary due to size tolerances of the combinations and of the worktop cut-out. Operates with magnetic (induction) iron pots and pans only. For an optimal heat distribution, the use of sandwich bottom cookware is recommended.

Special accessories

(please order as spare parts):
 Part No. 17006018
 Frying sensor pan, ø 20 cm
 Part No. 17006184
 Frying sensor pan, ø 24 cm
 Part No. 17006185
 Frying sensor pan, ø 28 cm

The wok pan WP 400 001 cannot be used with this appliance.
 Appliance must be fixed from underneath.
 Appliance weight: approx. 16 kg.

Please read the installation details regarding air ducting on page 210.

Connection

Total connected load 7.4 kW.
 Connecting cable 1.5 m without plug.
 Power consumption standby/display off 0.5 W.
 Power consumption standby/network 2.0 W.
 Please check the user manual for how to switch off the WiFi module.

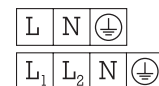

Installation of the cooktop; flush mounting

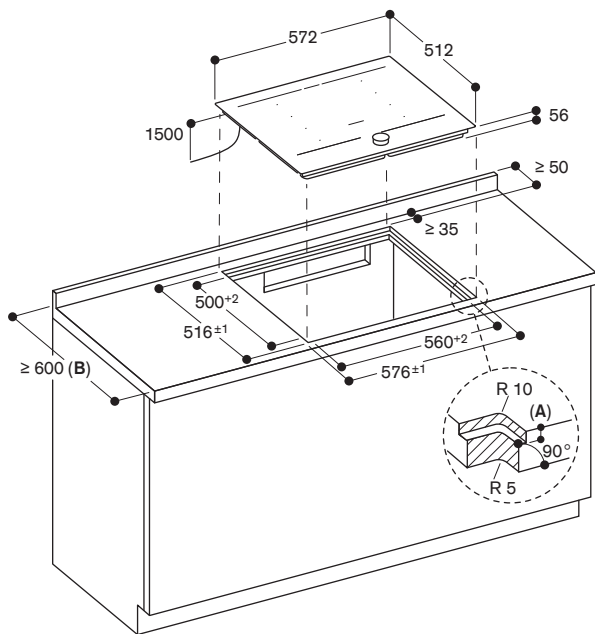

A: $6.5^{+0.5}$
 B: Please check the installation manual in case the worktop depth is below 600 mm.

measurements in mm

View from above

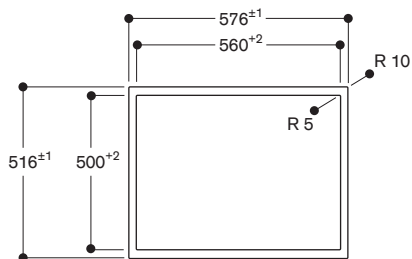

measurements in mm

Longitudinal section

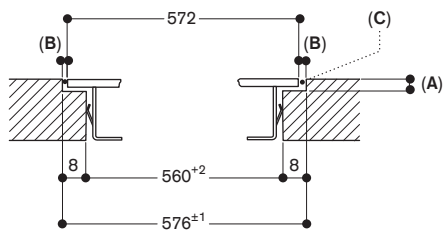

A: $6.5^{+0.5}$
 B: 2.5
 C: Fill with silicone

measurements in mm

Cross-section

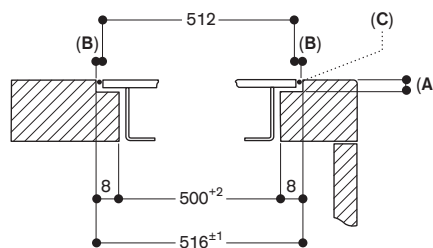

A: $6.5^{+0.5}$
 B: 2.5
 C: Fill with silicone
 measurements in mm



CI 262 115

Stainless steel frame
Width 60 cm

Special accessories

CA 051 301

Teppan Yaki plate made of multi ply material
For flex induction cooktop.

CA 052 300

Griddle plate in cast aluminium
Non-stick.
For flex induction cooktop.

CA 050 300

Flex Pan set, 3 pcs.
Non-stick coating.

For flex induction cooktop.

CA 055 300

Flex Pan large
Non-stick coating.

For flex induction cooktop.

CA 230 100

Black magnetic knob for induction cooktop 200 series
Stainless steel knob with black coating.

Flex induction cooktop 200 series

CI 262

- Sturdy stainless steel frame
- Flex function for combining the rectangular cooking areas
- Free positioning of cookware inside combined cooking areas with automatic extension up to 30 cm width
- Cooking sensor function for temperature control in pots
- Professional cooking function for splitting the cooktop into predefined heat areas
- Frying sensor function for temperature control in pans
- Twist-Pad control with removable magnetic knob
- Easy control of all functions with bicoloured display

Cooking zones

2 flex induction cooking areas 22,5x19 cm (2200 W, with booster 3700 W), linked together 22,5x38 cm (3300 W, with booster 3700 W), with automatic extension up to 30x30 cm (3300 W, with booster 3700 W).

2 flex induction cooking areas 22,5x19 cm (2200 W, with booster 3700 W), linked together 22,5x38 cm (3300 W, with booster 3700 W), with automatic extension up to 30x30 cm (3300 W, with booster 3700 W).

Handling

Twist-Pad control with removable magnetic knob.
User friendly control with bicoloured display (white / orange).
Cooking zone and cooking area marking.
Electronic power control in 17 output levels.

Features

Flex function for rectangular cooking areas.
Professional cooking function.
Cooking sensor function (in use with cooking sensor CA 060 300).
Frying sensor function.
Booster function for pots.
Booster function for pans.
Keep warm function.
Stopwatch.
Cooking timer for up to 99 minutes.
Short-term timer.
Options menu.
Power management.

Selected digital services

(Home Connect)

Cooktop-based ventilation control (with suitable hood).
Remote monitoring.
Remote diagnostics.

Please read additional information on Home Connect on page 411.

Safety

Main switch.
Operation indicator.
Pot detection.
2-stage residual heat indication.
Child lock.
Safety shut-off.

Planning notes

Installation is possible in worktops made of stone, synthetics or solid wood. Heat resistance and watertight sealing of the cut edges must be observed. Concerning other materials please consult the worktop manufacturer. Operates with magnetic (induction) iron pots and pans only. For an optimal heat distribution, the use of sandwich bottom cookware is recommended.

Special accessories

(please order as spare parts):
Part No. 17006018

Frying sensor pan, ø 20 cm

Part No. 17006184

Frying sensor pan, ø 24 cm

Part No. 17006185

Frying sensor pan, ø 28 cm

The wok pan WP 400001 cannot be used with this appliance.

Appliance must be fixed from underneath.
Appliance weight: approx. 16 kg.

Please read the installation details regarding air ducting on page 210.

Connection

Total connected load 7.4 kW.
Connecting cable 1.5 m without plug.
Power consumption standby/display off 0.5 W.
Power consumption standby/network 2.0 W.
Please check the user manual for how to switch off the WiFi module.

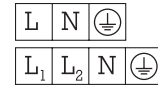

Installation of the cooktop; surface mounting

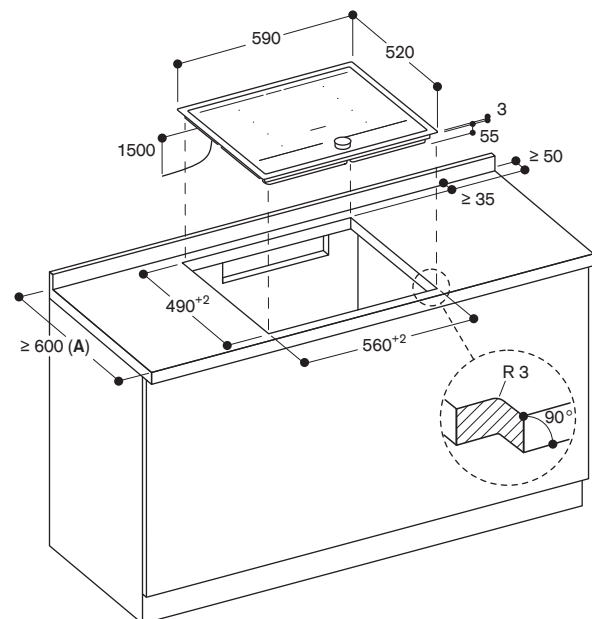

A: Please check the installation manual in case the worktop depth is below 600 mm.

measurements in mm

**CI 261 115**

Stainless steel frame
Width 60 cm

Special accessories**CA 051 301**

Teppan Yaki plate made of multi ply material
For flex induction cooktop.

CA 052 300

Griddle plate in cast aluminium
Non-stick.
For flex induction cooktop.

CA 050 300

Flex Pan set, 3 pcs.
Non-stick coating.
For flex induction cooktop.

CA 055 300

Flex Pan large
Non-stick coating.
For flex induction cooktop.

CA 230 100

Black magnetic knob for induction cooktop 200 series
Stainless steel knob with black coating.

Flex induction cooktop 200 series**CI 261**

- Sturdy stainless steel frame
- Flex function for combining the rectangular cooking areas
- Free positioning of cookware inside combined cooking areas with automatic extension up to 30 cm width
- Sensor control with direct selection of output level
- Easy control of all functions with bicoloured display

Cooking zones

2 flex induction cooking areas 22.5x19 cm (2200 W, with booster 3700 W), linked together 22.5x38 cm (3300 W, with booster 3700 W), with automatic extension up to 30x30 cm (3300 W, with booster 3700 W).

1 induction cooking zone ø 21 cm (2500 W, with booster 3700 W).

1 induction cooking zone ø 15 cm (1600 W, with booster 2200 W).

Handling

Sensor control with direct selection of output level.

User friendly control with bicoloured display (white / orange).
Cooking zone and cooking area marking.
Electronic power control in 17 output levels.

Features

Flex function for rectangular cooking areas.
Booster function for pots.
Booster function for pans.
Keep warm function.
Cooking timer for up to 99 minutes.
Short-term timer.
Options menu.
Power management.
Personalisation function via Home Connect.

Selected digital services (Home Connect)

Cooktop-based ventilation control (with suitable hood).
Remote monitoring.
Remote diagnostics.

Please read additional information on Home Connect on page 411.

Safety

Main switch.
Operation indicator.
Pot detection.
2-stage residual heat indication.
Child lock.
Safety shut-off.
Pause function.

Planning notes

Installation is possible in worktops made of stone, synthetics or solid wood. Heat resistance and watertight sealing of the cut edges must be observed. Concerning other materials please consult the worktop manufacturer. Operates with magnetic (induction) iron pots and pans only. For an optimal heat distribution, the use of sandwich bottom cookware is recommended.

Special accessories

(please order as spare parts):
Part No. 17006018
Frying sensor pan, ø 20 cm
Part No. 17006184
Frying sensor pan, ø 24 cm
Part No. 17006185
Frying sensor pan, ø 28 cm

The wok pan WP 400001 cannot be used with this appliance.
Appliance must be fixed from underneath.
Appliance weight: approx. 12 kg.

Please read the installation details regarding air ducting on page 210.

Connection

Total connected load 7.4 kW.
Connecting cable 1.5 m without plug.
Power consumption standby/display off 0.5 W.
Power consumption standby/network 2.0 W.
Please check the user manual for how to switch off the WiFi module.

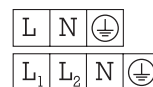
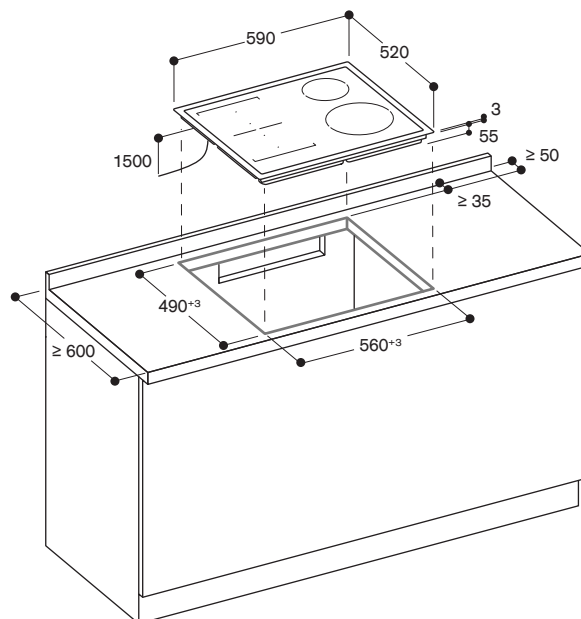
**Installation of the cooktop; surface mounting**

Measurements in mm

Installation notes for induction cooktops and glass ceramic cooktops

Applies to CU42., CI 26./27./28./29., CX 492/482, VI 414/422/462/482/492, VI 232/242/262 and CE 261/291.

Intake air ducting

Induction cooktops have a cooling fan to protect the appliance's electronics from overheating. In the case of insufficient air circulation in the cabinet, the appliance's output will be reduced to prevent electronic damage.

A Air duct behind a cabinet or built-in oven

An open cross-section of a minimum of 20 mm is needed across the full width and full height of the cabinet. Cabinets with a closed bottom also need a respective cross-section in the air duct area.

B Intake through the cabinet's back wall

In the cabinet's back wall, plan a recess of at least 45 mm (91 mm for CU421/CU428) in height from the worktop's bottom edge.

The minimum width is

- 300 mm for a 30 cm induction cooktop
- 350 mm for a 40 cm induction cooktop (also CU421/CU428)
- 550 mm for a Vario cooktop or a 60 cm to 80 cm induction cooktop
- 820 mm for a 90 cm induction cooktop

Intermediate shelf

To prevent the content of drawers underneath the cooktop from heating up, the use of an intermediate shelf is required for glass ceramic cooktops. Width of cut-out at least

- 100 mm for a 60 to 80 cm induction cooktop

* does not apply to 90 cm cooktops

- ** min. 65 mm for cooktops with frame as well as VI 462/482/492 for surface mounting
- min. 70 mm for cooktops without frame, for CX 482/492 with frame as well as for VI 462/482/492 for flush mounting.
- min. 80mm for CX 482/492 without frame
- min. 115mm for CU 421/428

Combination with other appliances

Installation above dishwasher or washing machine is not permitted.

Combination with AL 400

In addition to the measures mentioned above, the following unobstructed cross sections must be planned between the cabinet and the AL 400 to allow for proper intake and exhaust air circulation for the induction cooktop.

A In front of the air duct

20 mm distance between the back side of drawers, an oven or the cabinet's interior wall.

B Adjacent to the air duct

The resulting gap between the air duct and the cabinet's side wall needs to remain open.

C At the housing's rear edge

The resulting cross section between the housing and the wall, as well as between the housing and the floor, must remain open.

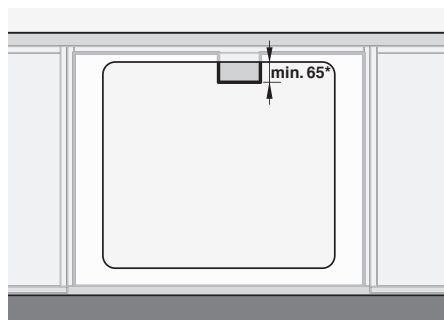
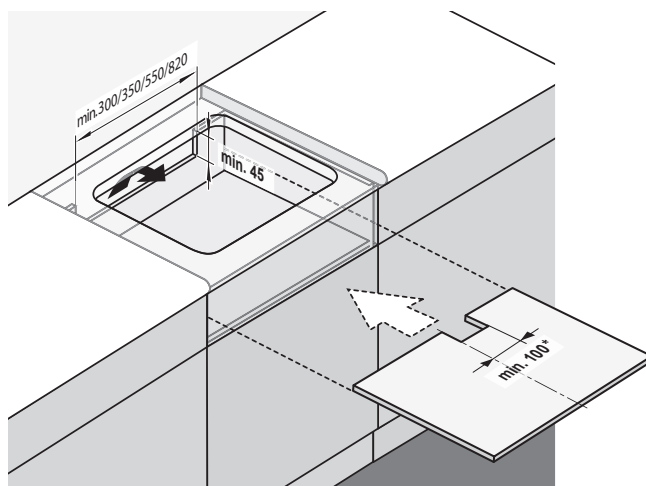
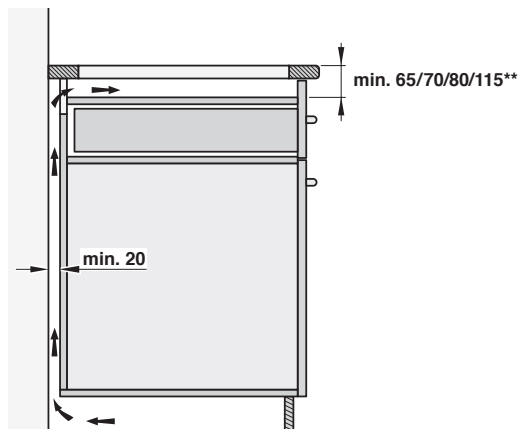



CE 291 101

Frameless
Width 90 cm

Included in the price

1 glass scraper

Glass ceramic cooktop 200 series

CE 291

- Frameless for flush mounting
- Frying sensor function
- Three-ring cooking zone up to 27 cm
- Large roasting zone
- Sensor control with direct selection of output level

Cooking zones

2 Super-Quick cooking zones ø 18 cm (1800 W); together they convert to 18x41.5 cm (4400 W) roasting zone.
1 Super-Quick cooking zone ø 12 cm (750 W), converts to ø 21 cm (2100 W, with booster 2600 W) cooking zone.
1 Super-Quick cooking zone ø 14.5 cm (1050 W), converts to ø 21 cm (2200 W) or ø 27 cm (3080 W) cooking zone.
1 Super-Quick cooking zone ø 14.5 cm (1200 W, with booster 1600 W).

Handling

Sensor control with direct selection of output level.
Cooking zone marking.
Electronic power control in 17 output levels.

Features

Frying sensor function for ø 21 cm cooking zone.
Booster function.
Cooking timer for up to 99 minutes.
Short-term timer.
Options menu.

Safety

Main switch.
Operation indicator.
2-stage residual heat indication.
Child lock.
Safety shut-off.

Planning notes

Immersion depth 51 mm, depth at plug socket 51 mm.
The cooktop must not be installed lower than the top edge of the worktop.
Under the plug socket, a 10 mm clearance must be observed from side panels or from intermediate shelf.
The cooktop must be freely accessible from underneath to be able to detach the cooktop's base in a downward direction.
Installation possible in a 60 cm wide lower cabinet.
Appliance must be fixed from underneath.
Cooktop clamping range: 20 – 50 mm.
Joint width may vary due to dimensional tolerances of the glass ceramic cooktop and the worktop cut-out.
Appliance weight: approx. 13 kg.

Please read the installation details regarding air ducting on page 210.

Connection

Total connected load 11.0 kW.
Plan a connection cable.

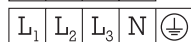
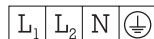

Installation of the cooktop; flush mounting

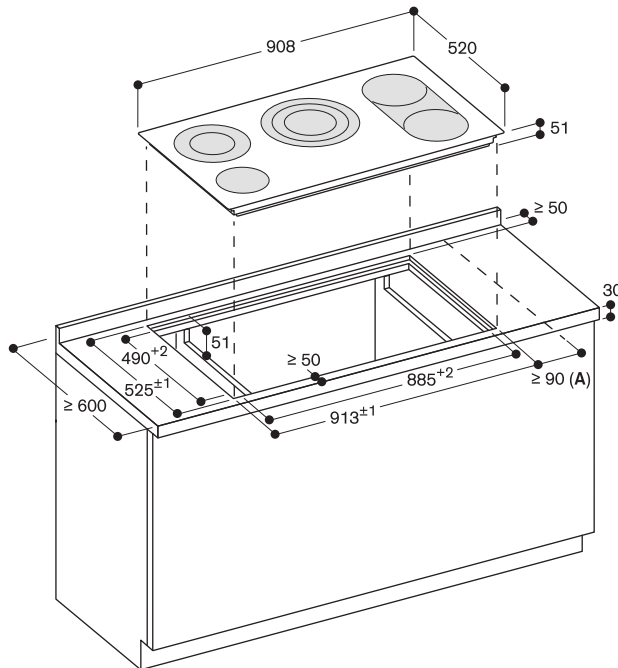

A: Minimum distance from the hob cut-out to the wall.

measurements in mm

View from above

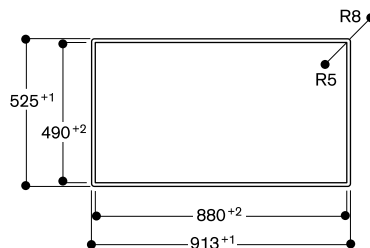

Longitudinal section

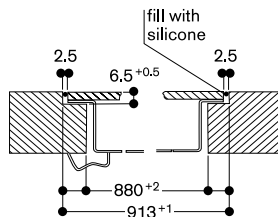

Cross section

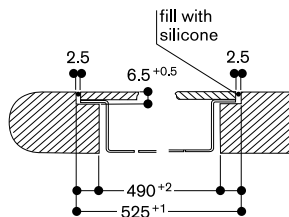



CE 291 111

Stainless steel frame
Width 90 cm

Included in the price

1 glass scraper

Glass ceramic cooktop 200 series

CE 291

- Sturdy stainless steel frame
- Frying sensor function
- Three-ring cooking zone up to 27 cm
- Large roasting zone
- Sensor control with direct selection of output level

Cooking zones

2 Super-Quick cooking zones \varnothing 18 cm (1800 W); together they convert to 18x41.5 cm (4400 W) roasting zone.
 1 Super-Quick cooking zone \varnothing 12 cm (750 W), converts to \varnothing 21 cm (2100 W, with booster 2600 W) cooking zone.
 1 Super-Quick cooking zone \varnothing 14.5 cm (1050 W), converts to \varnothing 21 cm (2200 W) or \varnothing 27 cm (3080 W) cooking zone.
 1 Super-Quick cooking zone \varnothing 14.5 cm (1200 W, with booster 1600 W).

Handling

Sensor control with direct selection of output level.
 Cooking zone marking.
 Electronic power control in 17 output levels.

Features

Frying sensor function for \varnothing 21 cm cooking zone.
 Booster function.
 Cooking timer for up to 99 minutes.
 Short-term timer.
 Options menu.

Safety

Main switch.
 Operation indicator.
 2-stage residual heat indication.
 Child lock.
 Safety shut-off.

Planning notes

Immersion depth 49 mm, depth at plug socket 50 mm.
 Under the plug socket, a 10 mm clearance must be observed from side panels or from intermediate shelf.
 The cooktop must be freely accessible from underneath to be able to detach the cooktop's base in a downward direction.
 Installation possible in a 60 cm wide lower cabinet.
 Appliance must be fixed from underneath.
 Cooktop clamping range: 20 – 50 mm.
 Appliance weight: approx. 13 kg.

Please read the installation details regarding air ducting on page 210.

Connection

Total connected load 11.0 kW.
 Plan a connection cable.

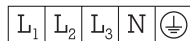
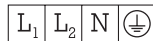

Installation of the cooktop; surface mounting

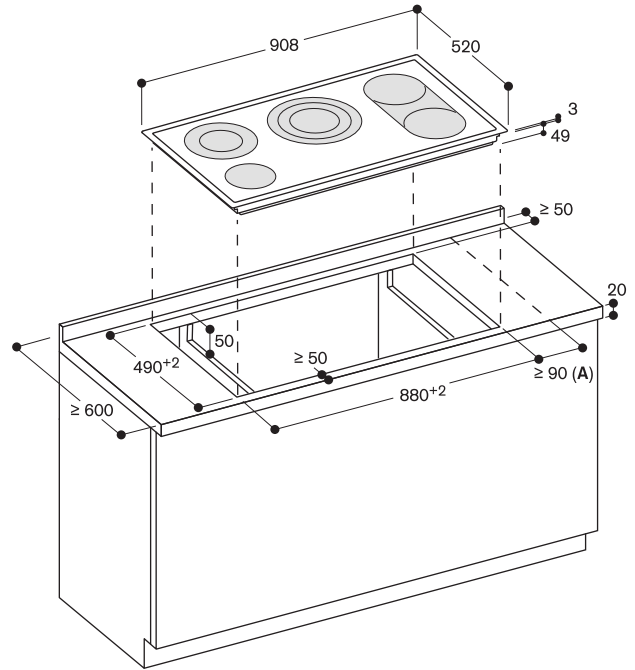

A: Minimum distance from the hob cut-out to the wall.

measurements in mm

**CE 261 114**

Stainless steel frame
Width 60 cm

Included in the price

1 glass scraper

Glass ceramic cooktop 200 series**CE 261**

- Sturdy stainless steel frame
- Sensor control with direct selection of output level

Cooking zones

1 Super-Quick cooking zone \varnothing 17 cm (1800 W), switches to 17 x 26,5 cm (2600 W) roasting zone.
1 Super-Quick cooking zone \varnothing 14.5 cm (1200 W), converts to \varnothing 21 cm (2100 W, with booster function 3000 W) cooking zone.
1 Super-Quick cooking zone \varnothing 18 cm (2000 W).
1 Super-Quick cooking zone \varnothing 14.5 cm (1200 W).

Handling

Sensor control with direct selection of output level.
Cooking zone marking.
Electronic power control in 17 output levels.

Features

Booster function.
Cooking timer for up to 99 minutes.
Short-term timer.
Options menu.

Safety

Main switch.
Operation indicator.
2-stage residual heat indication.
Child lock.
Safety shut-off.

Planning notes

Immersion depth 49 mm, depth at plug socket 50 mm.
Under the plug socket, a 10 mm clearance must be observed from side panels or from intermediate shelf.
The cooktop must be freely accessible from underneath to be able to detach the cooktop's base in a downward direction.
Installation possible in a 60 cm wide lower cabinet.
Appliance must be fixed from underneath.
Cooktop clamping range: 20 – 50 mm.
Appliance weight: approx. 8 kg.

Please read the installation details regarding air ducting on page 210.

Connection

Total connected load 8.3 kW.
Plan a connection cable.

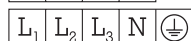
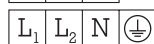
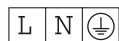
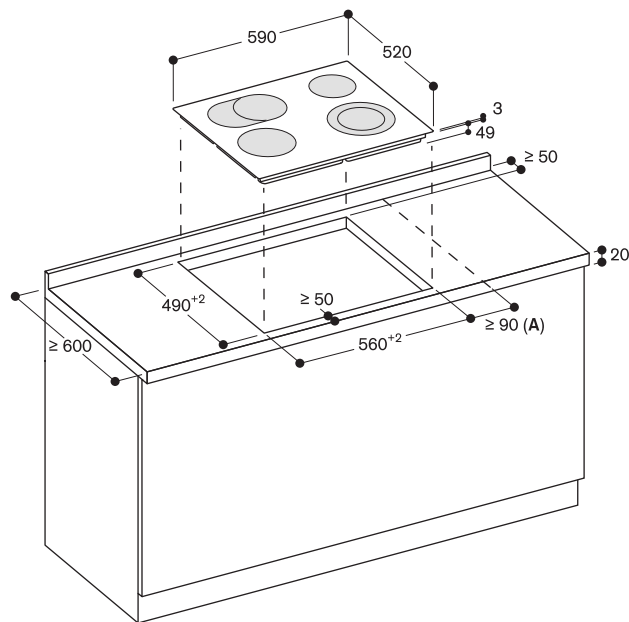
**Installation of the cooktop; surface mounting**

A: Minimum distance from the hob cut-out to the wall.

measurements in mm

Accessories and special accessories for cooktops

GN 232 110

Teppan Yaki plate made of multi ply material,
GN 1/1
For full surface induction cooktop.



GN 232 230

Teppan Yaki plate made of multi ply material,
GN 2/3
For full surface induction cooktop.



CA 051 301

Teppan Yaki plate made of multi ply material
For flex induction cooktops.



CA 052 300

Griddle plate in cast aluminium
Non-stick.
For flex induction cooktops.



CA 050 300

Flex Pan set, 3 pcs.
Non-stick coating.
For flex induction cooktop.



CA 055 300

Flex Pan large
Non-stick coating.
For flex induction cooktop.



SP 410 000*

Enhanced surface protector
For Pots and pans ø 10 – 14 cm
For CU421.



SP 415 000*

Enhanced surface protector
For Pots and pans ø 15 – 18 cm
For CU 421, CU 428.



SP 419 000*

Enhanced surface protector
For Pots and pans ø 19 – 23 cm
For CU 421, CU 428.



SP 424 000*

Enhanced surface protector
For Pots and pans ø 24 – 28 cm
For CU 421, CU 428.



SP 400 000*

Set of 4 enhanced surface protectors
For pots and pans ø 10 – 28 cm
For CU 421, CU 428.



WP 400 001

Wok pan made of multiple-layer material
With round bottom and handle,
ø36 cm, 6 litres, height 10 cm.



WZ 400 000

Wok attachment for wok pan



CA 060 300

Cooking sensor for temperature regulation within pots.



CA 230 100

Black magnetic knob for induction cooktop 200 series.
Stainless steel knob with black coating.



CA 414 110F

Socket



CA 414 100F

Black socket



CA 429 410

Frame set including decorative frame (to be welded in) and holding frame



VA 420 004

Connection strip for combination with other Vario appliances of the 400 series for flush mounting



VA 420 010

Connection strip for combination with other Vario appliances of the 400 series for surface mounting



CA 082 011

Kit unducted air recirculation for CV 282 / CV 482 / CV 492 consists of 4 activated charcoal filters with highly efficient odour reduction and allergen deactivation and telescopic connector

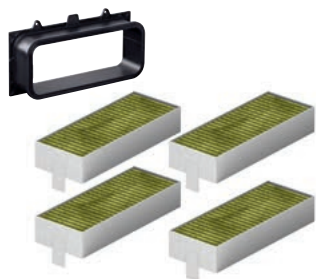
**CA 082 061**

Kit ducted air recirculation, 60 cm worktop depth for CV 282 / CV 482 / CV 492 consists of 4 activated charcoal filters with highly efficient odour reduction and allergen deactivation, extra short flat duct bend, flat duct, flat duct bend, flat duct connecting pieces and diffusor

**CA 082 071**

Kit ducted air recirculation, 70 cm worktop depth for CV 282 / CV 482 / CV 492 consists of 4 activated charcoal filters with highly efficient odour reduction and allergen deactivation, flat duct bends, flat duct, flat duct connecting pieces and diffusor

**CA 084 010**

4 acoustic filters for air extraction mode for CV 282 / CV 482 / CV 492

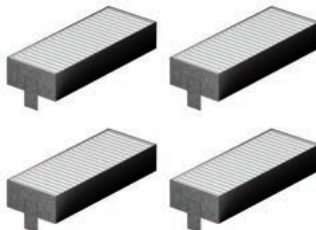
**CA 282 112**

4 recirculation replenishment filters for CV 282 / CV 482 / CV 492 with highly efficient odour reduction and allergen deactivation

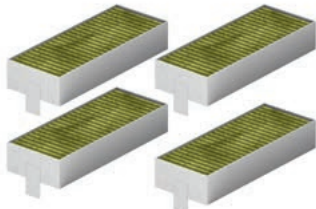
**AD 857 033**

Short flat duct bend 90° for installation of CV 282 / CV 482 / CV 492 in 65 cm deep worktops for exhaust and ducted recirculation.

**AD 857 034**

Extra short flat duct bend 90° for installation of CV 282 / CV 482 / CV 492 in 60 cm deep worktops for exhaust and ducted recirculation.

**AD 857 050**

Plinth diffusor that can be directly connected to the flat duct elements and spreads the outflowing air in the plinth area for ducted recirculation.



Gas cooktops 400 series



Appliance type	Gas cooktop	Gas cooktop
	CG 492 111F	CG 492 211
Stainless steel frame 3 mm / Stainless steel brushed / shot blasted	-/•/-	-/•/-
Surface mounting / Flush mounting / Welded	-/•/•	-/•/•
Liquid gas 28-37 mbar / Natural gas 20 mbar	•/-	-/•
Dimensions		
Width	(cm) 100	100
Depth	(cm) 59.9	59.9
Immersion depth	(cm) 15.7	15.7
Operation		
Knobs in furniture front / Knobs on integrated control panel	•/-	•/-
Cooking zones		
Number of cooking zones or items of cookware	5	5
Multi-ring wok burner (300 – 5800 W)	1	–
Multi-ring wok burner (300 – 6000 W)	–	1
Two-ring high output burner (165 – 4000 W)	2	2
Two-ring standard burner (165 – 2000 W)	2	2
Features		
Number of output levels	12	12
Electronic output control	•	•
Automatic fast ignition / Electric ignition	•/-	•/-
Electronic flame monitoring with automatic re-ignition	•	•
Simmer function	•	•
Residual heat indicator	•	•
Safety shut-off	•	•
Cast pan support	3-part	3-part
Accessories		
Wok attachment ring	•	•
Wok pan	WP 400 001 ¹	WP 400 001 ¹
Appliance cover (Stainless steel / Black)	-/-	-/-
Connection		
Total connected load gas (up to)	(kW) 17.8	18.0
Total connected load electric	(W) 15.0	15.0

• Standard. – Not available.

¹ Special accessory.



Appliance type	Gas cooktop	Gas cooktop	Gas cooktop	Gas cooktop
	VG 295 120F	VG 295 220	CG 291 210	CG 261 210
Stainless steel frame / Stainless steel brushed / shot blasted	-/-/•	-/-/•	-/•/-	-/•/-
Surface mounting / Flush mounting / Welded	•/-/-	•/-/-	•/-/-	•/-/-
Liquid gas 28-37 mbar / Natural gas 20 mbar	• ² /-	-/• ³	-/• ⁵	-/• ⁵
Dimensions				
Width	(cm) 90	90	90	60
Depth	(cm) 51	51	52	52
Immersion depth	(cm) 10.6	10.6	4.5	4.5
Operation				
Knobs in furniture front / Knobs on integrated control panel	-/•	-/•	-/•	-/•
Cooking zones				
Number of cooking zones or items of cookware	5	5	5	4
Multi-ring wok burner (1550 – 4000 W)	-	-	-	1
Multi-ring wok burner (300 – 5000 W)	-	-	1	-
Multi-ring wok burner (300 – 5800 W)	1	-	-	-
Multi-ring wok burner (300 – 6000 W)	-	1	-	-
Two-ring high output burner (170 – 4000 W)	2	2	-	-
Two-ring standard burner (170 – 2000 W)	2	2	-	-
High output burner (500 – 3000 W)	-	-	1	1
Standard burner (290 – 1750 W)	-	-	-	1
Standard burner (350 – 1750 W)	-	-	2	-
Economy burner (330 – 1000 W)	-	-	1	1
Features				
Number of output levels	9	9	9	9
Electronic output control	-	-	-	-
Automatic fast ignition / Electric ignition	-/•	-/•	-/•	-/•
Electronic flame monitoring with automatic re-ignition	-	-	-	-
Simmer function	-	-	-	-
Residual heat indicator	•	•	-	-
Safety shut-off	-	-	-	-
Cast pan support	3-part	3-part	3-part	2-part
Accessories				
Wok attachment ring	•	•	•	•
Wok pan	WP 400 001 ¹	WP 400 001 ¹	WP 400 001 ¹	WP 400 001 ¹
Appliance cover (Stainless steel / Black)	-/-	-/-	-/-	-/-
Connection				
Total connected load gas (up to)	(kW) 17.8	18.0	12.5	9.75
Total connected load electric	(W) 10.0	10.0	1.0	1.0

• Standard. – Not available.

¹ Special accessory.

² Nozzles for natural gas 20 mbar can be ordered as spare parts.

³ Nozzles for liquid gas 28-30/37 mbar can be ordered as spare parts.

⁴ Nozzles for liquid gas 50 mbar can be ordered as spare parts.

⁵ Nozzles for liquid gas 28-30/37 mbar are included.

⁶ Nozzles for liquid gas 50 mbar are included.

Induction cooktops 400 series



Appliance type	Integrated induction module	Integrated induction module
Integrated induction module	CU 428 100	CU 421 100
Frameless for flush mounting		
Stainless steel frame 3 mm for surface or flush mounting		
Dimensions		
Width	(cm) 50,6 ⁵	33,3 ⁵
Depth	(cm) 61 ⁵	61 ⁵
Immersion depth	(cm) 9.6	9.6
Operation		
Knobs in furniture front / Knobs on integrated control panel	•/-	•/-
TFT touch display / Twist-Pad control / Sensor control	-/-/-	-/-/-
Bicoloured display (white/orange)	-	-
Respective knobs (Stainless steel / Black) ⁴	CKU 410 010 / CKU 410 000	CKU 410 010 / CKU 410 000
Cooking zones / combinations		
Number of cooking zones or items of cookware	1	1
Full surface induction cooktop	-	-
Induction cooking zone ø 21 cm (2000, with booster 2300 W)	-	•
Induction cooking zone ø 28 cm (2200, with booster 2700 W)	•	-
Features		
Number of output levels	12	12
Flex function for rectangular cooking areas	-	-
Cooking sensor function / Frying sensor function	-/-	-/-
Frying sensor function: Number of cooking zones	-	-
Professional cooking function	-	-
Booster function for pots / pans	•/-	•/-
Keep warm function	•	•
Cooking timer: Number of cooking zones	-	-
Short-term timer	-	-
Stopwatch	-	-
Residual heat indicator	•	•
Child lock / Safety shut-off / Display cleaning protection	-/•/-	-/•/-
Pause function	-	-
Options menu	•	•
Hood control	-	-
Home network integration for digital services (Home Connect) wireless via WiFi.	-	-
Accessories		
Teppan Yaki plate made of multi ply material, GN1/1 (for full surface induction)	-	-
Teppan Yaki made of multi ply material, GN2/3 (for full surface induction)	-	-
Teppan Yaki made of multi ply material (for flex induction)	-	-
Griddle plate in cast aluminium (for flex induction)	-	-
Flex Pan set, 3 pcs. (for flex induction)	-	-
Flex Pan large (for flex induction)	-	-
Cooking sensor	-	-
Enhanced surface protector for pots and pans ø 10 – 14 cm	-	SP 410 000 ¹
Enhanced surface protector for pots and pans ø 15 – 18 cm	SP 415 000 ¹	SP 415 000 ¹
Enhanced surface protector for pots and pans ø 19 – 23 cm	SP 419 000 ¹	SP 419 000 ¹
Enhanced surface protector for pots and pans ø 24 – 28 cm	SP 424 000 ¹	-
Set of 4 enhanced surface protectors for pots and pans ø 10 – 28 cm	SP 400 000 ¹	SP 400 000 ¹
Connection		
Total connected load electric	(kW) 2.7	2.3

• Standard. – Not available.

¹ Special accessories.

² In combination with suitable hood.

³ The availability of the Home Connect functionality depends on the Home Connect Services in your country.

⁴ Knobs need to be ordered separately.

⁵ Aluminium diffusor plate



Full surface induction cooktop Full surface induction cooktop

CX 492 101 CX 482 101
 CX 492 111 CX 482 111

90 80
 52 51.3 / 52
 7.6 / 6.5 7.6 / 6.5

-/- -/-
 •/-/- •/-/-
 - -
 - -

6 5
 • •
 - -
 - -

17 17
 - -
 •/- •/-
 - -
 • •
 •/• •/•
 • •
 6 5
 • •
 • •
 • •
 •/•/• •/•/•
 • •
 • •
 •² •²
 •³ •³

GN 232 110¹ GN 232 110¹
 GN 232 230¹ GN 232 230¹
 CA 051 301¹ CA 051 301¹
 - -
 - -
 - -
 CA 060 300¹ CA 060 300¹
 - -
 - -
 - -
 - -

7.4 7.4

Induction cooktops with integrated ventilation system 400 and 200 series



Appliance type	Flex induction cooktop with integrated ventilation system	Flex induction cooktop with integrated ventilation system
Frameless for flush mounting	CV 492 105	CV 482 105
Stainless steel frame for surface or flush mounting	-	-
Dimensions		
Width	(cm) 90	80
Depth	(cm) 52.1	52.1
Immersion depth	(cm) 22.7	22.7
Operation		
Knobs in furniture front / Knobs on integrated control panel	•/-	•/-
TFT touch display / Twist-Pad control / Sensor control	•/-/-	•/-/-
Bicoloured display (white/orange)	•	•
Respective knobs (Stainless steel / Black) ²	CKI 440 010 / CKI 440 000	CKI 440 010 / CKI 440 000
Cooking zones / combinations		
Number of cooking zones or items of cookware	4	4
Flex induction cooking areas 23 x 19 cm (2200, with booster 3700 W) / linked together 23 x 38 cm (3300, with booster 3700 W)	4	-
Flex induction cooking areas 24 x 19 cm (2200, with booster 3700 W) / linked together 24 x 38 cm (3300, with booster 3700 W)	-	4
Automatic extension up to 30cm/32cm width (3300, with booster 3700 W)	2	-
Air extraction performance (EN 61591), power level 1 / 2 / 3 / Intensive		
Air extraction	(m ³ /h) 359/470/532/636	359/470/532/636
Air recirculation	(m ³ /h) 280/382/487/611	280/382/487/611
Consumption data according to EU regulation 65/2014		
Energy efficiency class	A [*]	A [*]
Energy consumption	kWh/year 56.9	56.9
Ventilation efficiency class	A**	A**
Illumination efficiency class	-	-
Grease filter efficiency class	B**	B**
Sound level min. / max. normal mode	dB(A) 61/70	61/70
Features cooking		
Number of output levels	12	12
Flex function for rectangular cooking areas	•	•
Cooking sensor function / Frying sensor function	•/•	•/•
Frying sensor function: Number of cooking zones	4	4
Professional cooking function	-	-
Booster function for pots / pans	•/-	•/-
Memory function	-	-
Keep warm function	-	-
Cooking timer: Number of cooking zones	-	-
Short-term timer	•	•
Stopwatch	•	•
Residual heat indicator	•	•
Child lock / Safety shut-off / Display cleaning protection	-/•/•	-/•/•
Pause function	-	-
Options menu	•	•
Home network integration for digital services (Home Connect) wireless via WiFi. ³	•	•
Features ventilation		
Power levels	3 plus intensive	3 plus intensive
Fan technology	BLDC	BLDC
Fan	1	1
Fan output	(W) 170	170
Fully automatic ventilation system functions	•	•
Automatic function	•	•
Run-on function automatic	•	•
Run-on function	(min) • / 20-30 min.	• / 20-30 min.
Interval ventilation	(min) • / 6 min.	• / 6 min.
Grease filter saturation indicator	•	•
Activated charcoal filter saturation indicator	•	•
Grease filter art	Metal grease filter	Metal grease filter
Grease filter units	2	2
Overflow container	•	•
Exhaust air connection bottom / side / back	-/-/•	-/-/•
Accessories		
Teppan Yaki made of multi ply material (for flex induction)	CA 051 301 ¹	CA 051 301 ¹
Griddle plate in cast aluminium (for flex induction)	CA 052 300 ¹	CA 052 300 ¹
Flex Pan set, 3 pcs. (for flex induction)	CA 050 300 ¹	CA 050 300 ¹
Flex Pan large (for flex induction)	CA 055 300 ¹	CA 055 300 ¹
Frying sensor pan (available via customer service), ø20 – 32 cm ⁴	17006... ¹	17006... ¹
Cooking sensor	-	-
Recirculation Module	CA 082 011 ¹ , CA 082 061 ¹ , CA 082 071 ¹	CA 082 011 ¹ , CA 082 061 ¹ , CA 082 071 ¹
Acoustic filter for air extraction mode	CA 084 010 ¹	CA 084 010 ¹
Connection		
Total connected load electric	(kW) 7.4	7.4

• Standard. - Not available. ¹ Special accessories.

^{*} Energy efficiency class: at a range of energy efficiency classes from A+++ to D. ² Knobs need to be ordered separately.

³ The availability of the Home Connect functionality depends on the Home Connect Services in your country. ⁴ Please find the suitable cookware on the product pages.

** Ventilation, Illumination, Grease filter efficiency: at a range of classes from A to G.



Flex induction cooktop with integrated ventilation system

Flex induction cooktop with integrated ventilation system

CV 282 101

-

-

CV 282 111

80

80

51.2

52

22.7

22.3

-/-

-/-

•/•/-

•/•/-

•

•

-

-

4

4

-

4

4

-

-

-

359/470/532/636

359/470/532/636

280/382/487/611

280/382/487/611

A*

A*

56.9

56.9

A**

A**

-

-

B**

B**

61/70

61/70

17

17

•

•

•/•

•/•

4

4

•

•

•/•

•/•

•

•

•

•

4

4

•

•

•

•

•

•

•/•/-

•/•/-

•

•

•

•

3 plus intensive

3 plus intensive

BLDC

BLDC

1

1

170

170

•

•

•

•

•

•

• / 20-30 min.

• / 20-30 min.

• / 6 min.

• / 6 min.

•

•

•

•

Metal grease filter

Metal grease filter

2

2

•

•

-/-/•

-/-/•

CA 051 301¹

CA 051 301¹

CA 052 300¹

CA 052 300¹

CA 050 300¹

CA 050 300¹

CA 055 300¹

CA 055 300¹

17006...¹

17006...¹

CA 060 300¹

CA 060 300¹

CA 082 011¹, CA 082 061¹, CA 082 071¹

CA 082 011¹, CA 082 061¹, CA 082 071¹

CA 084 010¹

CA 084 010¹

7.4

7.4

Flex induction cooktops 200 series



Appliance type	Flex induction cooktop
Frameless for flush mounting	CI 292 102
Stainless steel frame for surface or flush mounting	CI 292 112
Dimensions	
Width	(cm) 90
Depth	(cm) 52
Immersion depth	(cm) 5.6 / 5.5
Operation	
Knobs in furniture front / Knobs on integrated control panel	-/-
TFT touch display / Twist-Pad control / Sensor control	-/•/-
Bicoloured display (white/orange)	•
Cooking zones / combinations	
Number of cooking zones or items of cookware	5
Full surface induction cooktop	-
Flex induction cooking areas 21 x 19 cm (2200, with booster 3700 W) / linked together 21 x 38 cm (3300, with booster 3700 W)	-
Flex induction cooking areas 23 x 19 cm (2200, with booster 3700 W) / linked together 23 x 38 cm (3300, with booster 3700 W)	4
Flex induction cooking areas 24 x 19 cm (2200, with booster 3700 W) / linked together 24 x 38 cm (3300, with booster 3700 W)	-
Automatic extension up to 30cm/32cm width (3300, with booster 3700 W)	-
Induction cooking zone ø 21 cm (2200, with booster 3700 W) / ø 26 cm (2600, with booster 3700 W) / ø 32 cm (3300, with booster 3700 W)	1
Induction cooking zone ø 18 cm (1800, with booster 3100 W) / Roaster zone 18 x 28 cm (2000, with booster 3700 W)	-
Induction cooking zone ø 15 cm (1400, with booster 2200 W)	-
Induction cooking zone ø 15 cm (1600, with booster 2200 W)	-
Induction cooking zone ø 19 cm (1800, with booster 3100 W)	-
Induction cooking zone ø 21 cm (2200, with booster 3700 W)	-
Induction cooking zone ø 21 cm (2500, with booster 3700 W)	-
Induction cooking zone ø 24 cm (2200, with booster 3700 W)	-
Induction cooking zone ø 28 cm (2400, with booster 3700 W)	-
Features	
Number of output levels	17
Flex function for rectangular cooking areas	•
Cooking sensor function / Frying sensor function	•/•
Frying sensor function: Number of cooking zones	5
Professional cooking function	•
Booster function for pots / pans	•/•
Keep warm function	•
Cooking timer: Number of cooking zones	5
Short-term timer	•
Stopwatch	•
Residual heat indicator	•
Child lock / Safety shut-off / Display cleaning protection	•/•/•
Pause function	-
Options menu	•
Hood control	• ²
Home network integration for digital services (Home Connect) wireless via WiFi.	• ³
Accessories	
Teppan Yaki made of multi ply material, GN1/1 (for full surface induction)	-
Teppan Yaki made of multi ply material, GN2/3 (for full surface induction)	-
Teppan Yaki made of multi ply material (for flex induction)	CA 051 301 ¹
Griddle plate in cast aluminium (for flex induction)	CA 052 300 ¹
Flex Pan set, 3 pcs. (for flex induction)	CA 050 300 ¹
Flex Pan large (for flex induction)	CA 055 300 ¹
Frying sensor pan (available via customer service), ø 20 – 32 cm ⁴	17006... ¹
Cooking sensor	CA 060 300 ¹
Black magnetic knob (for induction cooktop series 200)	CA 230 100 ¹
Connection	
Total connected load electric	(kW) 11.1

• Standard. – Not available.

¹ Special accessories.

² In combination with suitable hood.

³ The availability of the Home Connect functionality depends on the availability of the Home Connect Services in your country.

⁴ Please find the suitable cookware on the product pages.



Flex induction cooktop	Flex induction cooktop	Flex induction cooktop	Flex induction cooktop	Flex induction cooktop
CI 283 103	CI 282 102	CI 272 103	CI 262 105	-
CI 283 113	CI 282 112	CI 272 113	CI 262 115	CI 261 115
80	80	70	60	60
51.3 / 52	51.3 / 52	51.2 / 52	51.2 / 52	52
5.6 / 5.5	5.6 / 5.5	5.6 / 5.5	5.6 / 5.5	5.5
-/-	-/-	-/-	-/-	-/-
-/•/-	-/•/-	-/•/-	-/•/-	-/•/•
•	•	•	•	•
5	4	4	4	4
-	-	-	-	-
2	-	-	-	-
-	4	4	4	2
-	2	-	-	-
-	2/-	1/-	1/-	1/-
-	-	-	-	-
-	-	-	-	-
1	-	-	-	-
-	-	-	-	1
1	-	-	-	-
-	-	-	-	-
-	-	-	-	1
1	-	-	-	-
-	-	-	-	-
17	17	17	17	17
•	•	•	•	•
•/•	•/•	•/•	•/•	-/-
2	4	4	4	-
•	•	•	•	-
•/•	•/•	•/•	•/•	•/•
•	•	•	•	•
5	4	4	4	4
•	•	•	•	•
•	•	•	•	-
•	•	•	•	•
•/•/•	•/•/•	•/•/•	•/•/•	•/•/-
-	-	-	-	•
•	•	•	•	•
•2	•2	•2	•2	•2
•3	•3	•3	•3	•3
-	-	-	-	-
-	-	-	-	-
CA 051 301 ¹	CA 051 301 ¹	CA 051 301 ¹	CA 051 301 ¹	CA 051 301 ¹
CA 052 300 ¹	CA 052 300 ¹	CA 052 300 ¹	CA 052 300 ¹	CA 052 300 ¹
CA 050 300 ¹	CA 050 300 ¹	CA 050 300 ¹	CA 050 300 ¹	CA 050 300 ¹
CA 055 300 ¹	CA 055 300 ¹	CA 055 300 ¹	CA 055 300 ¹	CA 055 300 ¹
17006... ¹	17006... ¹	17006... ¹	17006... ¹	17006... ¹
-	CA 060 300 ¹	CA 060 300 ¹	CA 060 300 ¹	-
CA 230 100 ¹	CA 230 100 ¹	CA 230 100 ¹	CA 230 100 ¹	-
7.4	7.4	7.4	7.4	7.4

EB 333

Ovens 400 series

Ovens 200 series

Vario cooktops

Cooktops

Extractors

Cooling appliances

Dishwashers | Washing machine

Energy Label | Home Connect | Accessories

Glass ceramic cooktops 200 series



Appliance type	Glass ceramic cooktop	Glass ceramic cooktop
Frameless for flush mounting	CE 291 101	
Stainless steel frame for surface or flush mounting	CE 291 111	CE 261 114
Dimensions		
Width	(cm) 90	60
Depth	(cm) 52	52
Immersion depth	(cm) 5.1 / 4.9	4.9
Operation		
Knobs in furniture front / Knobs on integrated control panel	-/-	-/-
TFT touch display / Twist-Pad control / Sensor control	-/-/•	-/-/•
Cooking zones / combinations		
Number of cooking zones or items of cookware	5	4
Super-Quick cooking zone ø 18 cm (1800 W) / together convertible to roasting zone 18 x 41.5 cm (4400 W)	2	-
Super-Quick cooking zone ø 18 cm (2000 W)	-	1
Super-Quick cooking zone ø 17 cm (1800 W) / Roaster zone 17 x 26.5 cm (2600 W)	-	1
Super-Quick cooking zone ø 14.5 cm (1200, with booster 1600 W)	1	-
Super-Quick cooking zone ø 14.5 cm (1200 W)	-	1
Super-Quick cooking zone ø 14.5 cm (1050 W) / ø 21 cm (2200 W) / ø 27 cm (3080 W)	1	-
Super-Quick cooking zone ø 14.5 cm (1200 W) / ø 21 cm (2100, with booster 3000W)	-	1
Super-Quick cooking zone ø 12 cm (750 W) / ø 21 cm (2100, with booster 2600 W)	1	-
Features		
Number of output levels	17	17
Frying sensor function: Number of cooking zones	1 x 21 cm	-
Booster function for pots / pans	•	•
Cooking timer: Number of cooking zones	5	4
Residual heat indicator	•	•
Child lock / safety shut-off / display cleaning protection	•/•/-	•/•/-
Options menu	•	•
Connection		
Total connected load electric	(kW) 11.0	8.3

• Standard. – Not available.

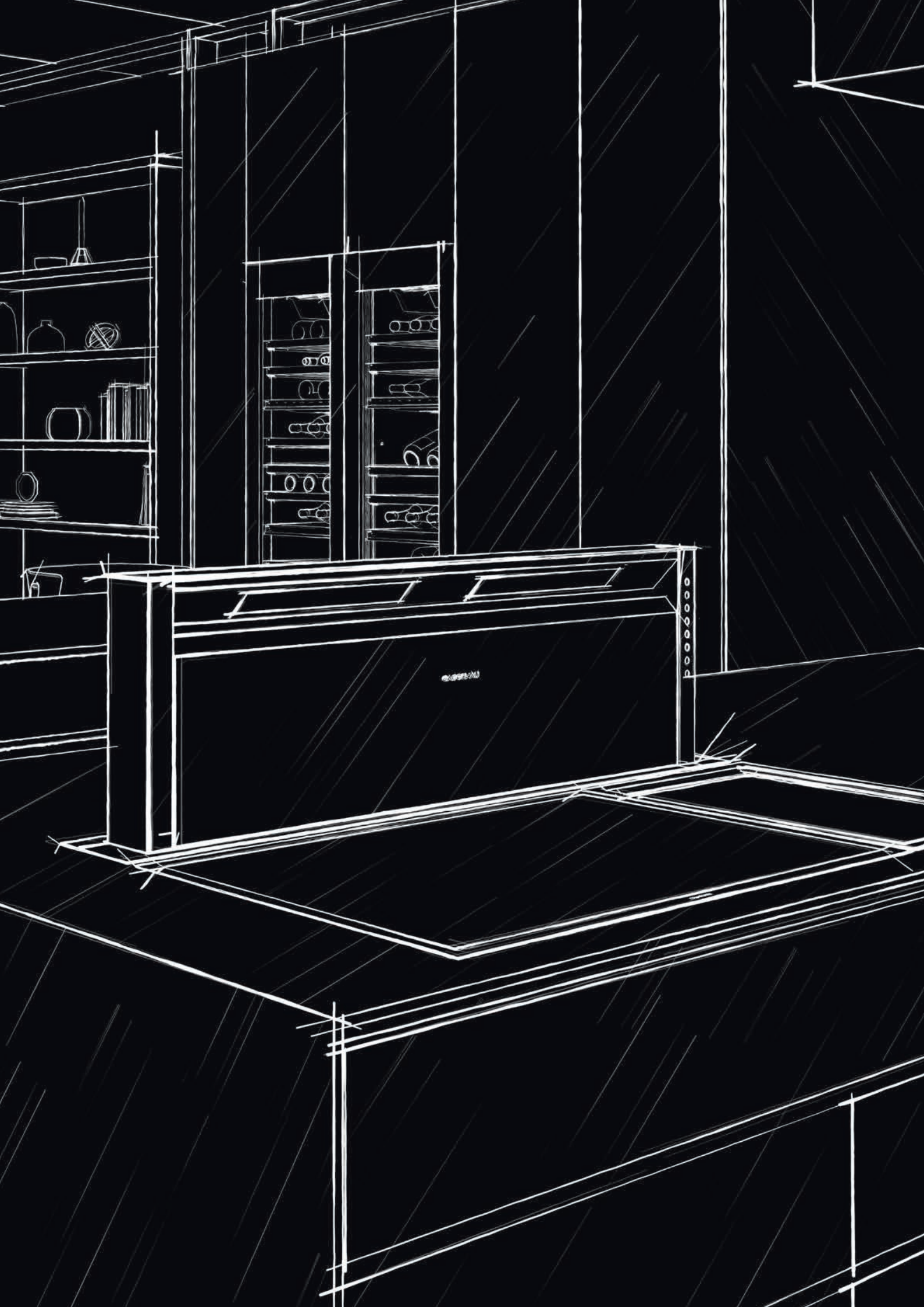

The extractors

Ceiling ventilation	232
Table ventilation	236
Downdraft ventilation	254
Wall-mounted hoods	266
Island hood	270
Flat kitchen hoods	272
Canopy extractors	274
Remote fan units	276
Accessories special accessories	282
Technical specifications	294

Overview

Ceiling ventilation

400 series



• AC 402 181



• AC 482 181
• AC 472 181



• AR 400 142



• AR 401 142



• AR 403 122

200 series



Integrated
• AC 250 121

Table ventilation

400 series



• AL 400 192
• AL 400 122



• AR 400 142



• AR 401 142



• AR 403 122



• AR 413 122



• AR 410 110 only with
AL 400 122

200 series



• AL 200 180
• AL 200 190

Downdraft ventilation

400 and 200 series



• VL 414 115



• VL 200 120



• AR 400 142



• AR 401 142



• AR 403 122



• AR 413 122



• AR 410 110



• CKV 410 010
• CKV 410 000

Wall-mounted hood

400 series



• AW 442 120



• AR 400 142



• AR 401 142



• AR 400 143

200 series



• AW 240 191

Island hood

200 series



• AI 240 191

Flat kitchen hoods

200 series



• AF 210 162
• AF 210 192

Canopy extractors

200 series



• AC 200 161
• AC 200 181
• AC 200 191

General planning notes

The aim of good ventilation system planning is to extract or filter the cooking vapours as quickly and as silent as possible.

To help you plan and install your cooking ventilation system correctly, here are a few important notes from our ventilation experts.

– **The cooking appliances:** The choice of cooktop is the decisive influencing factor. Every cooktop are not compatible with every ventilation appliances. The recommended Cooktop Ventilation Combinations are available in the first pages from M&D in the Vario cooktops and Cooktops chapters. In addition, if special Vario cooking appliances are to be installed, which can be expected to produce a higher amount of cooking vapours such as a Teppan Yaki, wok or electric grill, we recommend to install them, if possible, in the centre of the cooktop configuration and not at the edge. More over the cooktop(s) should not be wider than the hood.

– **The type of ventilation system:** Every type of ventilation system has particular planning characteristics. For all the ventilation appliances installed above the cooktops, the minimum distance between the worktop and the lower edge of the respective ventilation appliance is specified in the planning instructions of the M&D and should be respected. The extraction capacity reduces as the distance increases.

For ceiling ventilation appliances, the maximum distance between the cooktop and the ventilation appliance is 120 cm. In this case the maximum width of cooktops combination is 100 cm. Adding a frame or a fume collector, the maximum width of cooktops combination is 130 cm.

The ceiling ventilation has to be handled as a room ventilation when distance to cooktop is larger than 120 cm since the direct capture of vapours will be limited. Please consider to consult an HVAC (Heating and ventilation air conditioning) specialist.

The maximum distance between two downdraft ventilation should not be more than 80cm (except for the CX482 due to the full surface induction). Cooktops with a width of 60cm and 80cm (except the CX482), Vario cooktops like Vario electric grill or Vario gas wok should be placed between two downdraft ventilation.

– **The operation mode:** All Gaggenau ventilation systems can be operated both in exhaust air mode and air recirculation mode. In recirculation, please note that the Vario electric grill is not recommended.

The very hot cooking performances of the grill generate fumes and vapours when meats or vegetables are placed on. Due to the high temperature of the grill, the particles of fumes are thinner than those generated by another cooking appliances. None of our current odour filters are able to catch and to filter these grill fumes particles.

Please be aware that for EU countries, the table ventilation AL 400 122 is only recommended in air recirculation due to legislation EU 66/2014.

In air extraction mode, the extraction performance depends on the fan output, and also significantly on the duct system. See the ducting paragraph.

– **The fans:** Gaggenau ventilation systems are equipped with particularly powerful fans (200 series), or they can be combined with correspondingly powerful remote fan units 400 series for exhaust air or air recirculation mode. These fans are designed to minimise the pressure drop of the installation.

Thanks to the variety of remote fan units 400 series, the modular system allows for installation in the cabinet, plinth, cellar, ceiling and in outdoor areas.

– **The ducting and accessory:** To ensure the most effective catch of the vapours and fume, the installation between the ventilation appliance and the extraction exhaust should be as short and as straight as possible. This will ensure good extraction and acoustic performances.

In order to facilitate the planning, for all Gaggenau ventilation appliances, a recommended maximum ducting length is defined. This information is found under the name Lmax.

For installation with a ducting equivalence longer than Lmax please reconsider to change the ducting system to a straighter and shorter one.

For ventilation 400 series appliances, an additional blower in serie could be also a solution.

To define the best ventilation solution, please contact your sales representative to get advice from the Ventilation Service Gaggenau.

As every bend or accessory originate a pressure drop in the ducting system, to estimate the global performance of the installation, each component has to be summed based on the following equivalence.

		Ducting equivalence		
Gaggenau flat duct Length 0.5 m	AD 857 015			0.5 m
Gaggenau flat duct Length 1 m	AD 857 010		AD 854 010 	1 m
	AD 752 010			
Gaggenau bend	AD 857 030		AD 854 030 	3 m
	AD 857 031		AD 854 031 	
	AD 857 042		AD 854 032 	
	AD 752 030			
Gaggenau wall outlet	AD 750 054		AD 850 050 	11 m
One way flap	RK 040 150			3 m
Remote fan unit	AR 401 142			7 m
Remote fan unit	AR 400 142		AR 400 143 	0 m
	AR 403 122			

Further information

Please observe the local applicable building regulations when configuring ventilation solutions.

Example AL 200 180:

The equivalent ducting length to ensure good performance is Lmax 28 m.

Extraction Installation	Ducting equivalence
1.5 m Straight ducting	1.5 m
2 Bends	2 x 3 m
1 Wall outlet	11 m
TOTAL	18.5 m

This installation is equivalent to 18.5 m less than the max length allowable 28 m.
The installation is validated.

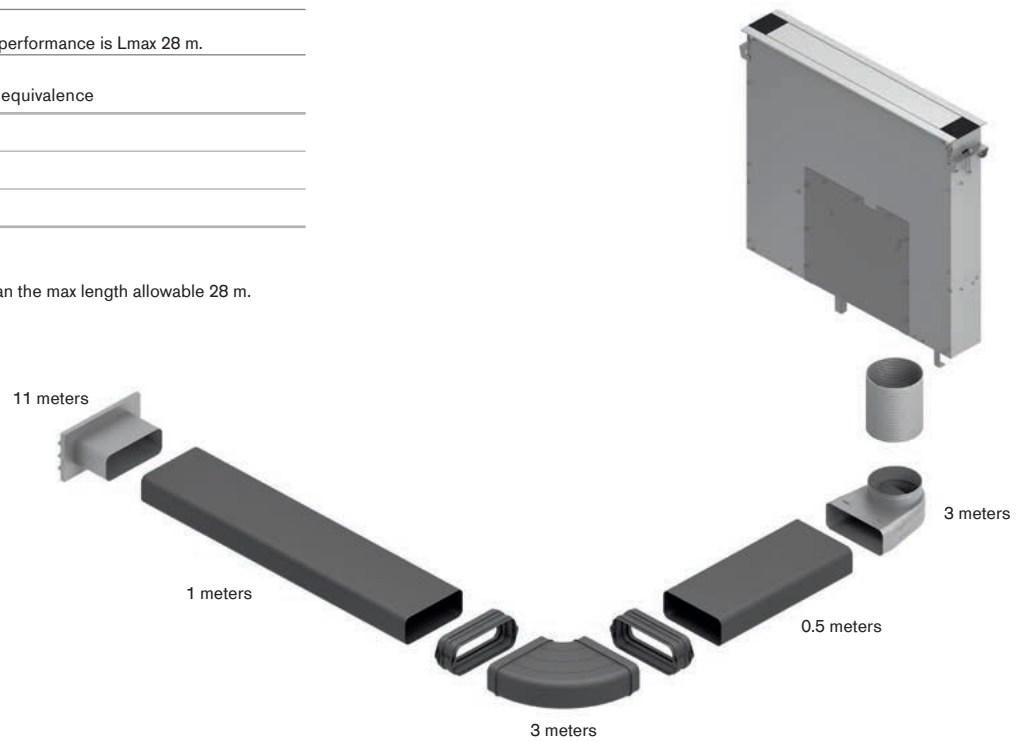



AC 402 181
Stainless steel
Filter module
Air extraction / Air recirculation
Motorless



In combination with remote fan units
AR 400 142
AR 401 142
AR 403 122

Installation accessories

AA 010 811
Stainless steel.

AA 012 811
White.

Air recirculation module inclusive
1 activated charcoal filter with highly efficient odour reduction and allergen deactivation.

For air recirculation.

AD 754 048

Air collector box DN 150 round pipe
Metal zinc plated
2 x DN 150 round duct air intake.
1 x DN 150 cylindrical duct air outlet.

AD 854 048

Air collector box DN 150 flat duct
Metal zinc plated with plastic
2 x DN 150 flat duct air intake.
1 x DN 150 flat duct air outlet.

Special accessories

AA 200 112

1 regenerable activated charcoal filter with highly efficient odour reduction.

Extended change interval of the activated charcoal filter: regenerable up to 30 times.

Regenerable in the oven at 200°C.

For air recirculation module

AA 200 812/816 and AA 010 811/
AA 012 811.

Installation accessories for air ducting you will find at the pages 287 – 293.

Special accessories

(order as spare parts):

Part No. 11033934

2 activated charcoal filters with highly efficient odour reduction and allergen deactivation.

For air recirculation module

AA 200 812/816 and AA 010 811/
AA 012 811.

Vario ceiling ventilation 400 series

AC 402

- Discreet integration into the architecture of the kitchen
- Flexible by dimension, performance and ventilation mode
- Room ventilation
- Modular ceiling ventilation which can be configured individually by separate components such as filter module, control modules and light module
- Motorless, can be combined with Gaggenau BLDC remote fan units
- Highly efficient patented rim extraction
- Planed and easy to clean underside with covered filters

Output

Noise level depends on the built-in situation.

Power levels depend on the remote fan unit.

Refer to the "Technical specifications" of the hood for the matching remote fan units for air recirculation or air extraction mode.

Features

Rim extraction filter, dishwasher-safe.
Installation frame for thread rods (threaded rods included in delivery).
Connecting pipe DN 150 round.

Consumption data

Consumption data is referred to a configuration with the remote fan unit AR 400 142.

Energy efficiency class B at a range of energy efficiency classes from A+++ to D.

Energy consumption 60.6 kWh/year.

Ventilation efficiency class A.

Illumination efficiency class E.

Grease filter efficiency class B.

Sound level min. 50 dB / max. 65 dB normal mode.

Planning notes

Lmax, the equivalent ducting length to ensure good performance is depending on the configuration.

For optimum extraction performance, the maximum distance between the cooktop and the ventilation appliance is 120 cm. The ceiling ventilation has to be handled as a room ventilation when distance to cooktop is larger than 120 cm since the direct capture of vapours will be limited.

Please consider to consult an HVAC (Heating and ventilation air conditioning) specialist.

For air recirculation an external air recirculation module is required.

Max. 3 filter modules to be connected to remote fan unit AR 400 142.

When installing remote fan unit within the ceiling or furniture block it must remain accessible through the ceiling cutout or another maintenance access.

When installing a ventilation hood with air extraction mode and a chimney-vented fireplace, the hood's power supply line needs a suitable safety switch.

Please read additional planning notes on page 233.



AC 482 181
Stainless steel
Control module with light

Vario ceiling ventilation 400 series

AC 482

- Control module of ceiling ventilation with light
- Individual integration of light elements into the configuration of the ceiling ventilation

Output

Power levels depend on the remote fan unit.

Refer to the "Technical specifications" of the hood for the matching remote fan units for air recirculation or air extraction.

Features

7-key infrared remote control, backup keys for operation also on the control module.

3 electronically controlled power levels and 1 intensive mode.

Interval ventilation, 6 min.

Run-on function, 6 min.

Grease filter saturation indicator.

Planning notes

Connection to the respective appliances via network cable.

When installing a ventilation hood with air extraction mode and a chimney-vented fireplace, the power supply line of the ventilation appliance needs a suitable safety switch.

Fixing at the filter module.

Please read additional planning notes on page 233.

Connection

Total connected load 15W.

Connecting cable 1.75 m, pluggable.

*Energy efficiency class: at a range of energy efficiency classes from A+++ to D.



Vario ceiling ventilation 400 series
AC 472

- Light module of ceiling ventilation
- Individual integration of light elements into the configuration of the ceiling ventilation

Features

Connection to the respective appliances via network cable.

Planning notes

Fixing at the filter module.

Please read additional planning notes on page 233.

Connection

Total connected load 4 W.
Connecting cable 1.75 m, pluggable.
Network cable 2 m.

AC 472 181
Stainless steel
Light module
For completing control module with light

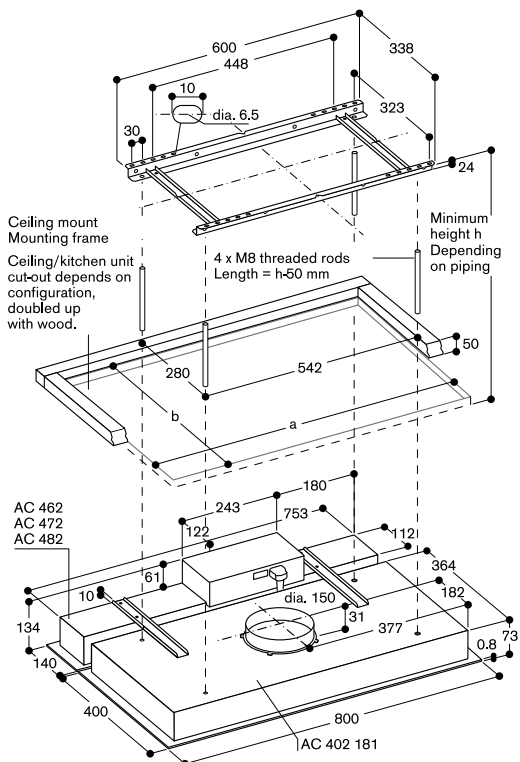

For multiple configurations:
Ceiling deflection around cut-out: max. + 3 mm.
Support is required in the middle to prevent deflection upwards when fastening the modules.
The required threaded rods, nuts and ceiling bolts are supplied as standard.

AC 402 with air recirculation module

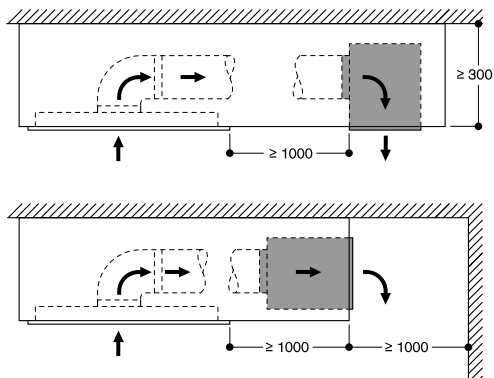

measurements in mm

Recommended configurations for ceiling ventilation 400 series

FL1-CL

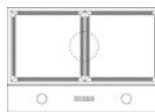

FL1-CL-L1

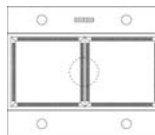

FL2-CL-L1



F2-CL

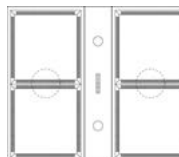

F3-CL-L1

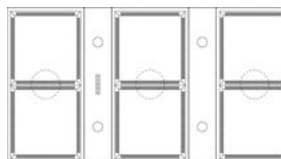

FL4-CL-L1

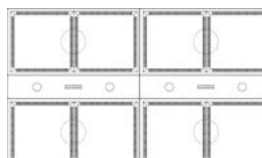

F4-CL-L2

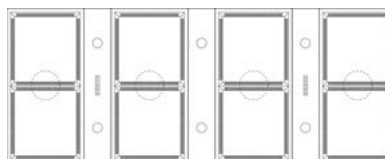

To define the best ventilation solution, please contact your sales representative to get advice from the Ventilation Service Gaggenau.



AC 250 121
Gaggenau Light Bronze
Width 120 cm
Air extraction / Air recirculation

A+ *

Included in the price
1 Remote control

Necessary installation accessories

AA 010 811
Stainless steel.

AA 012 811
White.

Air recirculation module inclusive
1 activated charcoal filter with highly efficient odour reduction and allergen deactivation.
For air recirculation.

Special accessories

AA 200 112
1 regenerable activated charcoal filter with highly efficient odour reduction. Extended change interval of the activated charcoal filter: regenerable up to 30 times.
Regenerable in the oven at 200 °C.
For air recirculation module
AA 200 812/816 and AA 010 811/
AA 012 811.

Installation accessories for air ducting you will find at the pages 287 – 293.

Ceiling ventilation 200 series AC 250

- Discreet integration into the architecture of the kitchen
- Energy-saving, low-noise fan
- Rim extraction
- Function for automatic, sensor-controlled power adjustment depending on the build-up of cooking vapours
- Easy and time saving installation directly in the ceiling
- Easy maintenance of the filters
- Air extraction / Air recirculation

Output

Performance and noise level, output level 3/Intensive:
Air output according to EN 61591.
Sound power level according to EN 60704-3.
Air extraction:
458 / 933 m³/h.
56 / 70 dB (A) re 1 pW.
Air recirculation:
419 / 637 m³/h.
63 / 72 dB (A) re 1 pW.

Features

3 electronically controlled power levels and 1 intensive mode.
Remote control is included in delivery.
Automatic function with sensor-controlled run-on function.
Interval ventilation, 6 min.
Grease filter saturation indicator.
Activated charcoal filter saturation indicator.
Metal grease filter, dishwasher-safe.
Massive aluminium anodized Gaggenau Light Bronze filter cover.
Fan technology with highly efficient, brushless DC motor (BLDC).
Turnable blower, air outlet on all four sides possible.
Connecting pipe DN 150 round.

Selected digital services (Home Connect)

Cooktop-based ventilation control (with suitable cooktop)
Remote control and monitoring
Remote diagnostics

Please read additional information on Home Connect on page 411.

Consumption data

Energy efficiency class A+ at a range of energy efficiency classes from A+++ to D.
Energy consumption 35.2 kWh/year.
Ventilation efficiency class A.
Grease filter efficiency class E.
Sound level min. 41 dB / max. 56 dB normal mode.

Planning notes

The equivalent ducting length to ensure good performance is L_{max} 23 m.

For optimum extraction performance, the maximum distance between the cooktop and the ventilation appliance is 120 cm.
In this case the maximum width of cooktops combination is 100 cm.
Adding a frame or a fume collector, the maximum width of cooktops combination is 130 cm.

The ceiling ventilation has to be handled as a room ventilation when distance to cooktop is larger than 120 cm since the direct capture of vapours will be limited.
Please consider to consult an HVAC (Heating and ventilation air conditioning) specialist.

A suitable load-bearing substructure is required for securing the extractor hood. Never fit the appliance directly onto plasterboard or similar lightweight construction materials.

Recommended minimum gap between appliance and external filter module: 100 cm.

For air recirculation an external air recirculation module is required.
Clearance above gas appliances min. 65 cm (more than total load gas 12 kW min. 70 cm).

Clearance above electric appliances min. 65 cm.

Air recirculation is not recommended in combination with Vario electric grill.

Please ensure when installing the exhaust air ducting that no sharp bends are caused and that the cross-section of the ducting is not constricted in any way.

When installing a ventilation hood with air extraction mode and a chimney-vented fireplace, the power supply line of the ventilation appliance needs a suitable safety switch.

Appliance weight: approx. 37 kg.

Special accessories

(order as spare parts):
Part No. 11033934
2 activated charcoal filters with highly efficient odour reduction and allergen deactivation.

For air recirculation module
AA 200 812/816 and AA 010 811/
AA 012 811.

Connection

Total connected load 250 W.
Connecting cable 1.3 m with plug.

*Energy efficiency class: at a range of energy efficiency classes from A+++ to D.

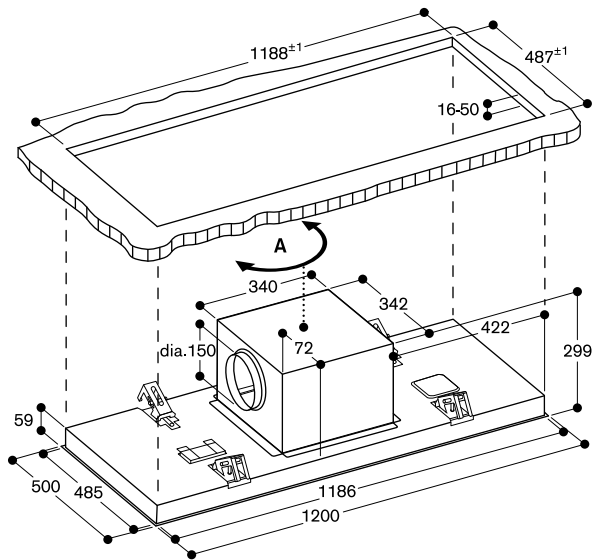

A: The ventilator outlet can be turned in all four directions.
measurements in mm

AC 250 with air recirculation module

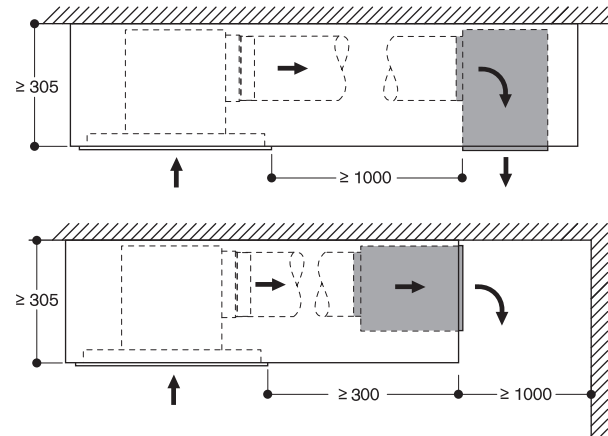

measurements in mm

Planning examples as a cooktop ventilation up to max. 120 cm distance to the cooktop.

AC 250 in a dry construction
Extraction toward the top in the attic

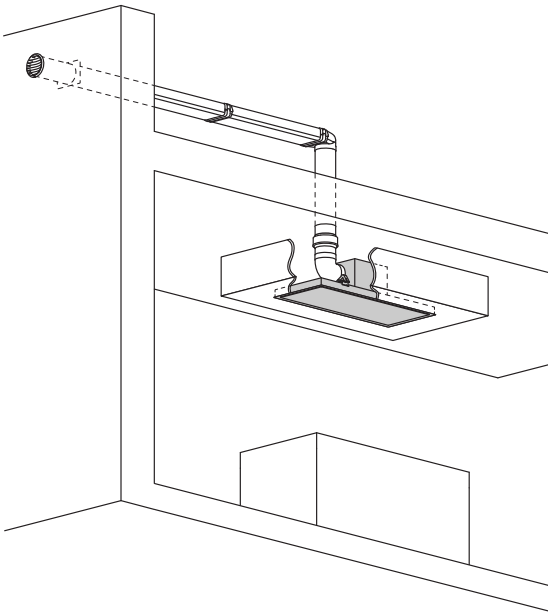

AC 250 in the suspended ceiling
Extraction directly toward an external wall

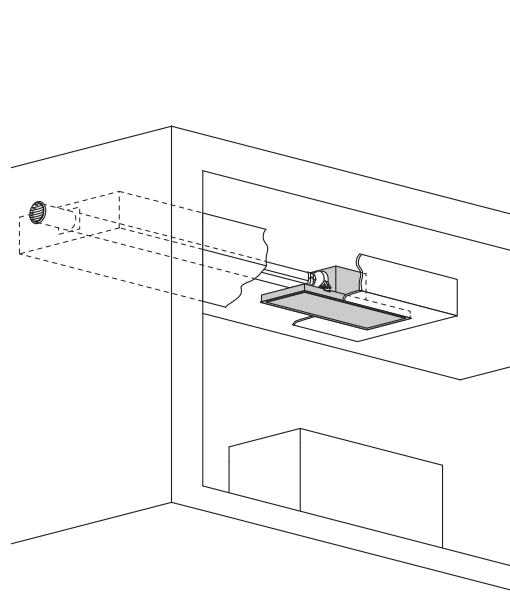

AC 250 in a dry construction with fume collector
Extraction thru a suspended ceiling

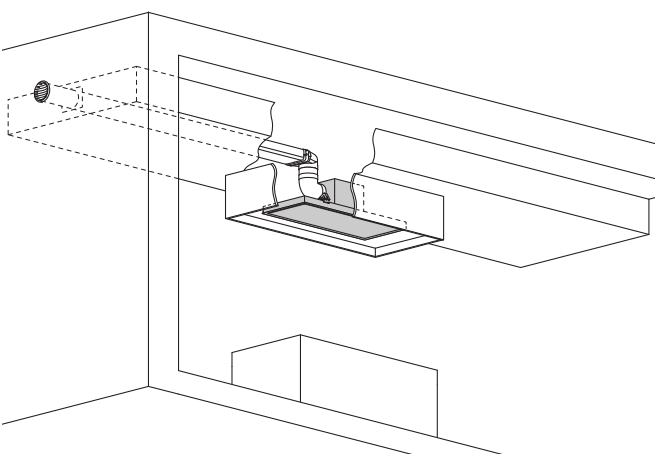

Dry construction integration with fume collector

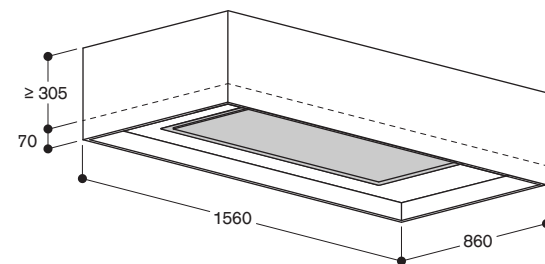

Measurements in mm



AL 400 122
 stainless steel
 Width 120 cm
 Air extraction / Air recirculation
 Motorless

AL 400 192
 stainless steel
 Width 90 cm
 Air extraction /
 Air recirculation
 Motorless



In combination with remote fan units
 AR 400 142
 AR 401 142
 AR 403 122
 AR 413 122
 AR 410 110 (only with AL 400 122)

Necessary installation accessories
Depending on the connection option (front, back, or bottom) one of the following accessories must be ordered.
AD 754 049
 Connecting piece for AL 400 (front or back side)
 Metal zinc coated
 DN 150 round

AD 854 050
 Connecting piece for AL 400 (bottom side)
 Metal zinc coated
 DN 150 flat

Installation accessories
AA 409 401
 Furniture support for table ventilation
 AL 400 90 cm

AA 409 431
 Furniture support for table ventilation
 AL 400 120 cm

AD 704 050
 Air collector box for AL 400
 Metal zinc coated
 DN 150 flat

Special accessories
AA 400 510
 Window contact switch

Installation accessories for air ducting you will find at the pages 287 – 293..

Table ventilation 400 series
AL 400

- Extendable table ventilation, when not in use can be completely lowered into the worktop
- Can be combined perfectly with all Vario cooktops 400 series
- Dimmable, neutral white surface LED light for ideal illumination of the cooktop
- Precision crafted 3 mm stainless steel
- For surface mounting with a visible edge or for flush mounting
- Motorless, can be combined with Gaggenau BLDC remote fan units

Output
 Power levels depend on the remote fan unit.
 Refer to the "Technical specifications" of the hood for the matching remote fan units for air recirculation or air extraction mode.

Features
 3 electronically controlled power levels and 1 intensive mode.
 Interval ventilation, 6 min.
 Run-on function, 6 min.
 Grease filter saturation indicator.
 2 large-scale metal grease filters included, easy to remove and dishwasher-safe.
 Grease drip trays, easy to remove and dishwasher-safe.
 Neutral white surface LED light (3600 K), continuously dimmable.
 Lamp output 2 x 10 W.
 Illuminance 400 lx.
 Flexible connection options to the remote fan unit: at the bottom, at the front or at the back.
 In all the options, it is possible to have space for drawers in front of the table ventilation.

Consumption data
 AL 400 192: Consumption data is referred to a configuration with the remote fan unit AR 400 142.
 Energy efficiency class A at a range of energy efficiency classes from A+++ to D.
 Energy consumption 45.5 kWh/year.
 Ventilation efficiency class A.
 Illumination efficiency class C.
 Grease filter efficiency class B.
 Sound level min. 45 dB / max. 61 dB normal mode.

AL 400 122: Recommended only in recirculation mode for EU countries, the consumption data is not mandatory in this mode.

Planning notes
 The equivalent ducting length to ensure good performance is Lmax 19 m.

AL 400 192: Combinable with all cooktops Vario 400 series, 400 series and 200 series. Maximum cooktops width: 90 cm.

AL 400 122: Combinable with all cooktops Vario 400 series and 400 series. Maximum cooktops width: 120 cm. It is recommended to use two remote fan units so that sufficient vapour captation will be ensured.

For EU countries due to legislation EU 66/2014 only air recirculation is recommended.
 Depending on the type of installation, the corresponding accessories must be ordered separately.
 Air recirculation is not recommended in combination with Vario electric grill. Operation of Vario cooking appliances only possible without appliance cover.

Max. output of cooktops 18 kW.
 The table ventilation must have its own worktop cut-out.
 The bearing capacity and stability, in the case of thin worktops in particular, must be supported using suitable substructures. Take into account the appliance weight and additional loads.
 The remaining surface of the worktop (min. 50 mm) between the cut-outs must be reinforced with a support. It is recommended to use furniture support AA 409 401/431.
 Additional instructions for flush mounting: Installation is possible in worktops made of stone, synthetics or solid wood. Heat resistance and watertight sealing of the cut edges must be observed. Concerning other materials please consult the worktop manufacturer. Depending on the type of installation, ovens can be combined with the table ventilation.

When installing a ventilation hood with air extraction mode and a chimney-vented fireplace, the power supply line of the ventilation appliance needs a suitable safety switch.
 The control unit should be accessible and be secured to a panel of the cabinet that avoids any risk of flooding.
 Please read additional planning notes on page 238 – 243.

Connection
 Total connected load 65 W
 Connecting cable 1.7 m with plug.
 Network cable 1.2 m.

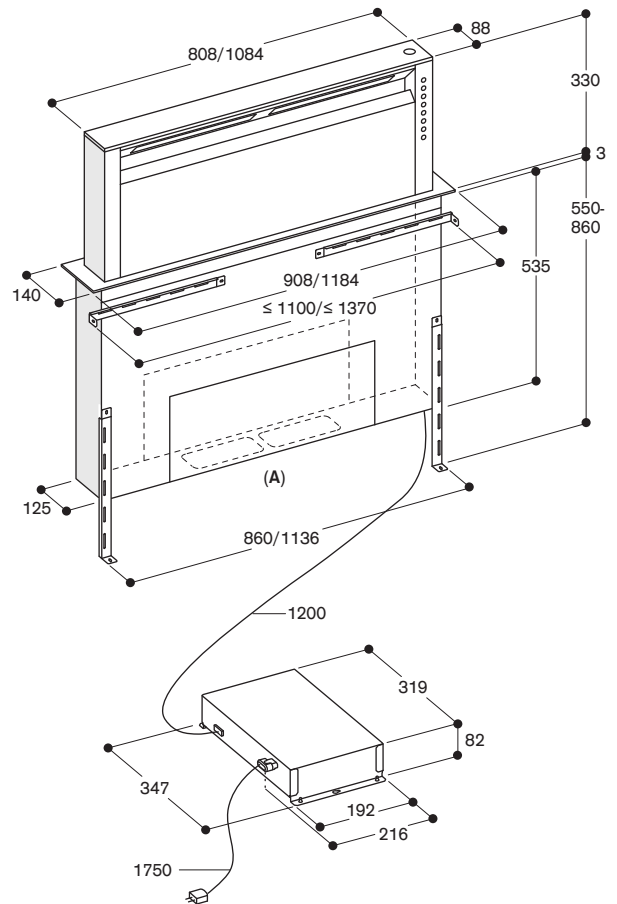

A: Flexible connection of the hood at the front, the back, or at the bottom

Measurements in mm

*Energy efficiency class: at a range of energy efficiency classes from A+++ to D.

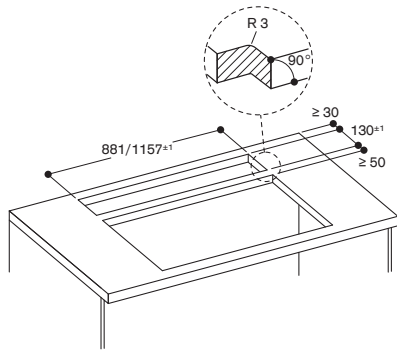

Measurements in mm

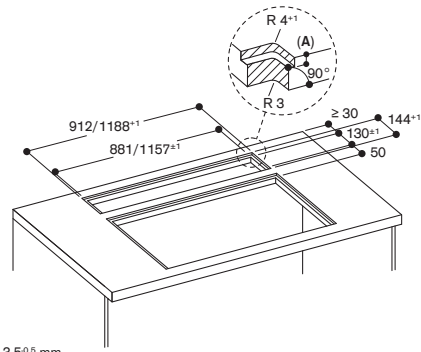

A: 3.5^{±0.5} mm

Measurements in mm

View from above

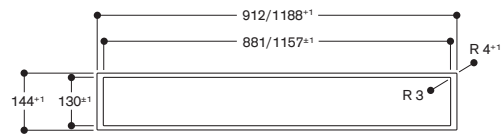

Measurements in mm

Longitudinal section

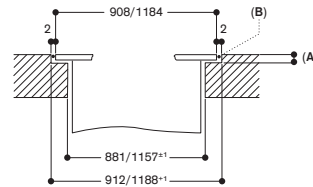

A: 3.5^{±0.5} mm
B: Fill with silicone

Measurements in mm

Cross section

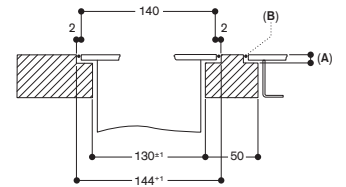

A: 3.5^{±0.5} mm
B: Fill with silicone

Measurements in mm

AD 754 049

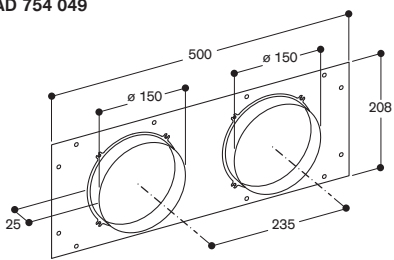

Measurements in mm

AD 704 050

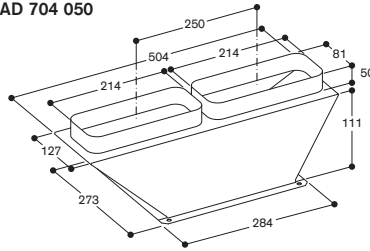

Measurements in mm

AD 854 050

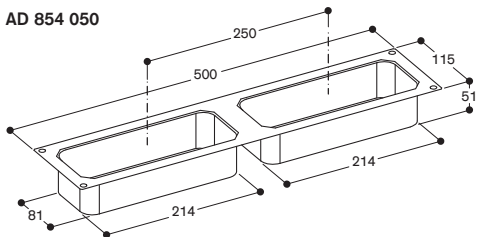

Measurements in mm

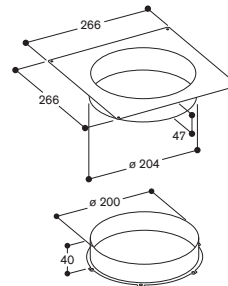

AA 409 401/431 furniture support

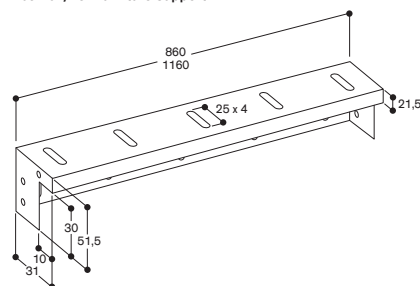

Recommended configurations for table ventilation 400 series

Good to know – for correct planning and installation

- For depth measurements, take account of the depth of the furniture cavity and worktop overhangs of the kitchen furniture.
- The ducting can essentially be connected to the front, the back or straight down. The respective connecting pieces are available for this purpose.
- It is also important that ducting is well sealed in order to prevent air leaks, e.g. by using the adequate adhesive tape or using the adequate connecting piece.
- Plastic ducts can be used for installation behind a gas appliance. The maximum permitted performance of the cooktops is 18 kW.
- For the AL 400 122 it is recommended to use two remote fan units, with this we can ensure a sufficient vapour captation. For EU countries, the AL 400 122 is only recommended in air recirculation due to legislation EU 66/2014.
- Vario cooktops with intensive vapour formation like Vario Teppan Yaki or Vario electric grill should be placed central in front of the ventilation appliance.
- In case of Vario electric grill air recirculation is not recommended.
- The control unit should be accessible and be secured to a panel of the cabinet that avoids any risk of flooding.
- Depending on the type of installation, the corresponding accessories must be ordered separately.

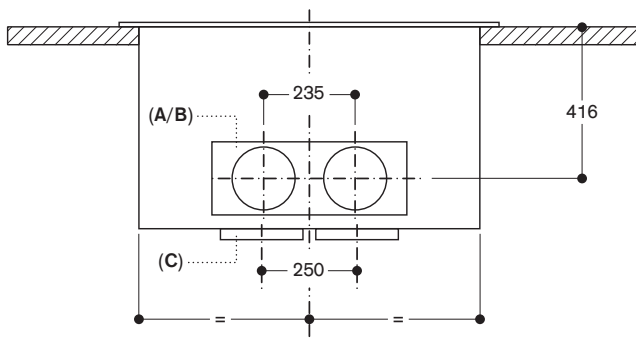
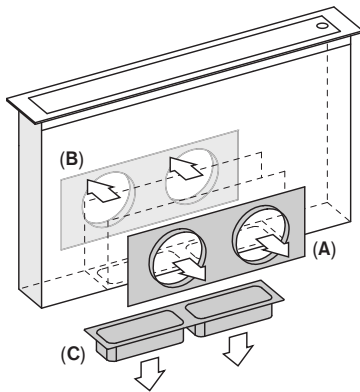

- A:** Connection at the front with AD 754 049
- B:** Connection at the back with AD 754 049
- C:** Connection at the bottom with AD 854 050

Measurements in mm

Planning example

AL 400 90 cm with AR 413 122 (air recirculation) remote fan unit

Good to know

- The air collector box can be screwed directly on the remote fan unit.
- For optimum performance, the recirculated air requires sufficient space to escape (outflow surface area of at least 400 cm²).

List of components

- 1 x AL 400 192
- 1 x AR 413 122 (remote fan unit air recirculation)
- 1 x AD 854 050 (connecting piece to the bottom)
- 2 x AD 858 010 (flat duct flex pipe)
- 1 x AD 704 050 (air collector flat duct)

Order as set (appliances and accessories): **SET1AL4105**

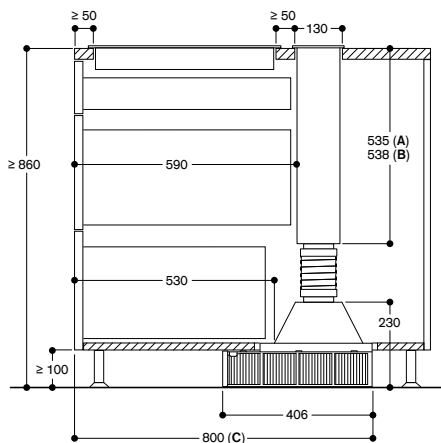
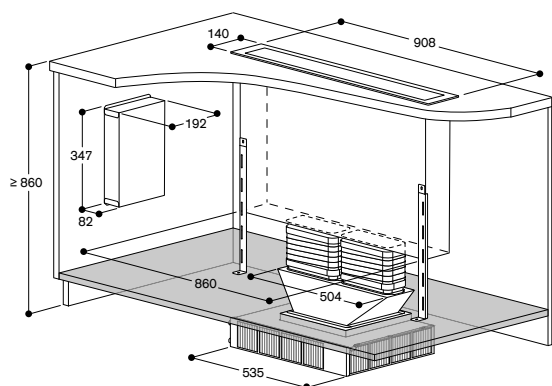

A: Surface mounting
 B: Flush mounting
 C: 750 mm with a worktop at min. height 920 mm
 Not recommended for non-thermally insulated floor ($U \geq 0.5 \text{ W/m}^2\text{K}$)
 Measurements in mm

Planning example

AL 400 90 cm with AR 413 122 (air recirculation) or AR 403 122 (air extraction) remote fan unit

Good to know

- The remote fan unit can be connected to the front or the back
- The air collector box can be screwed directly on the remote fan unit.
- Recirculation: For optimum performance, the recirculated air requires sufficient space to escape (outflow surface area of at least 400 cm²).
- Extraction : in the example exhaust is towards the left, it is also possible to the right, please be aware that the measures will be different.
- Please note, this installation is also possible with Gaggenau metal ducts.

List of components

- 1 x AL 400 192
- 1 x AR 413 122 (for recirculation) or 1 x AR 403 122 (for extraction)
- 1 x AD 754 049 (connecting piece round duct to front/back)
- 2 x AD 857 042 (flat duct adapter round 90°)
- 1 x AD 858 010 (flat duct flex pipe)
- 1 x AD 704 050 (air collector flat duct)
- 1 x AD 990 091 (adhesive tape aluminium)

Order as set for recirculation mode (appliances and accessories): **SET1AL4107**

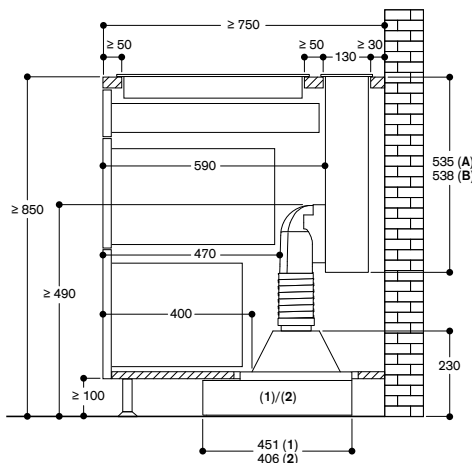
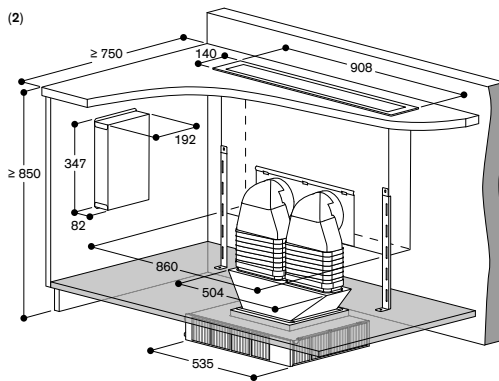
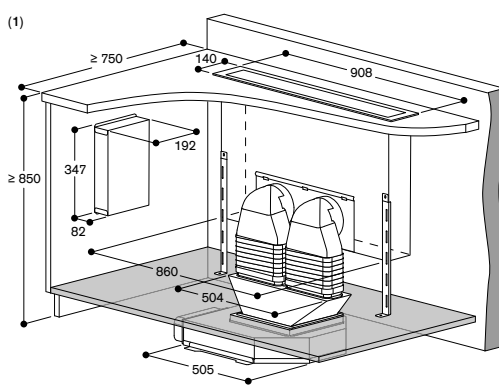

A: Surface mounting
 B: Flush mounting
 Planning with remote fan unit
 1: AR 403 122
 2: AR 413 122
 Not recommended for non-thermally insulated outer wall or floor ($U \geq 0.5 \text{ W/m}^2\text{K}$)
 Measurements in mm

Planning example
AL 400 90cm with AR 400 142 (air extraction) -
Cellar installation

Good to know

- Please note, these installations are also possible with Gaggenau metal ducts.
- Depending on the distance between the AL400 and the remote fan unit you may need more flat and round ducts.

List of components

- 1 x AL 400 192
- 1 x AR 400 142 (remote fan unit)
- 1 x AD 854 050 (connecting piece to the bottom)
- 2 x AD 857 010 (flat duct)
- 2 x AD 857 040 (flat duct connecting piece)
- 2 x AD 857 041 (flat duct adapter round)
- 1 x or more AD 752 010 (round duct)
- 1 x AD 751 010 (round duct flex pipe)
- 1 x AD 990 091 (adhesive tape)

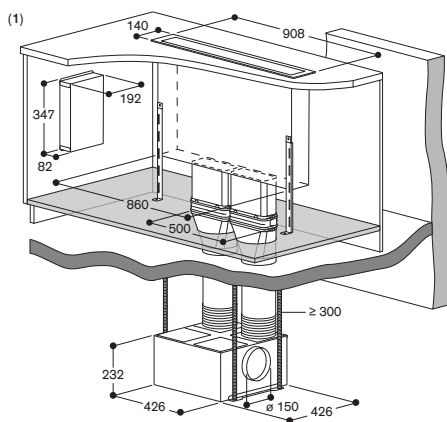

Planning example
AL 400 90cm with AR 401 142 (air extraction) -
Cellar installation with outside remote fan unit

List of components

- 1 x AL 400 192
- 1 x AR 401 142 (remote fan unit)
- 1 x AD 854 050 (connecting piece to the bottom)
- 2 x AD 857 010 (flat duct)
- 2 x AD 857 040 (flat duct connecting piece)
- 1 x or more AD 752 010 (round duct)
- 2 x AD 857 042 (flat duct adapter round 90°)
- 2 x or more AD 857 040 (flat duct connecting piece)
- 1 x or more AD 857 010 (flat duct)
- 1 x AD 704 050 (air collector flat duct)
- 1 x AD 702 052 (telescopic wall duct)
- 1 x AD 990 091 (adhesive tape)

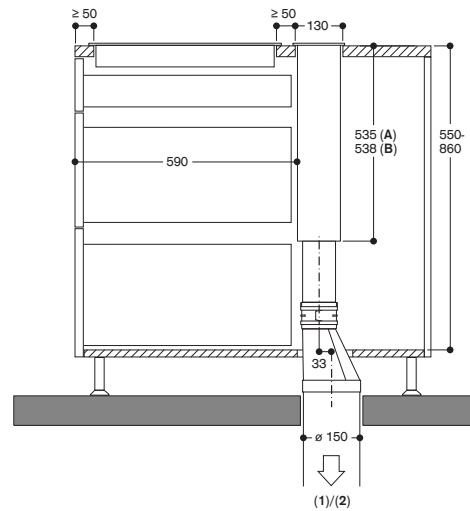
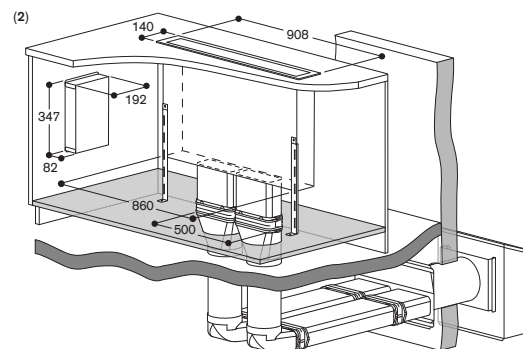

A: Surface mounting
B: Flush mounting

Extraction mode with remote fan unit
 1: AR 400 142
 2: AR 401 142

Measurements in mm

Planning example

AL 400 120 cm with AR 410 110 (air recirculation)

Good to know

- The remote fan units can be connected to the front or the back.
- For optimum performance, the recirculated air requires sufficient space to escape (outflow surface area of at least 800 cm² - 400 cm² for each remote fan unit).
- Please note, this installation is also possible with Gaggenau metal ducts.

List of components

- 1 x AL 400 122
- 2 x AR 410 110 (remote fan unit)
- 1 x AD 754 049 (connecting piece round duct to front/back)
- 2 x AD 857 042 (flat duct adapter round 90°)
- 2 x AD 858 010 (flat duct flex pipe)
- 1 x AD 990 091 (adhesive tape)

-Order as set (appliances and accessories): **SET2AL4301**

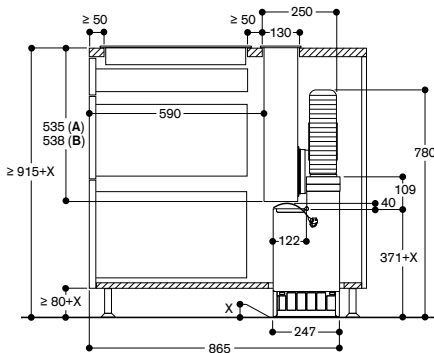
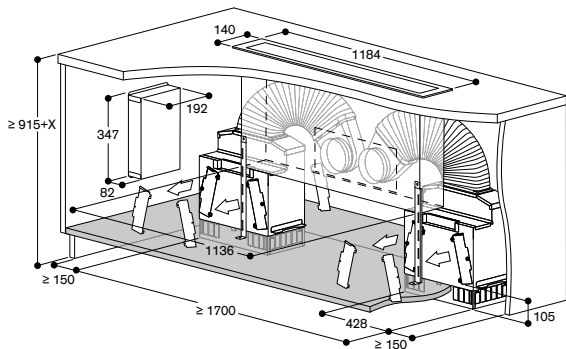

A: Surface mounting
B: Flush mounting

Not recommended for non-thermally insulated floor ($U \geq 0.5 \text{ W/m}^2\text{K}$)

Measurements in mm

Planning example

AL 400 120 cm with AR 413 122 (air recirculation) remote fan unit

List of components

- 1 x AL 400 122
- 2 x AR 413 122 (remote fan unit)
- 1 x AD 754 049 (connecting piece round duct to front/back)
- 2 x AD 857 042 (flat duct adapter round 90°)
- 1 x AD 858 010 (flat duct flex pipe)
- 2 x AD 857 041 (flat duct adapter round)
- 1 x AD 990 091 (adhesive tape)

-Order as set (appliances and accessories): **SET2AL4107**

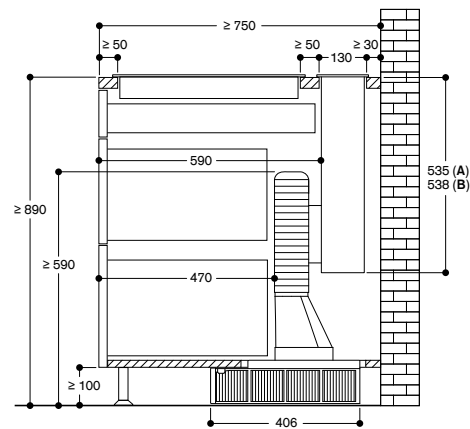
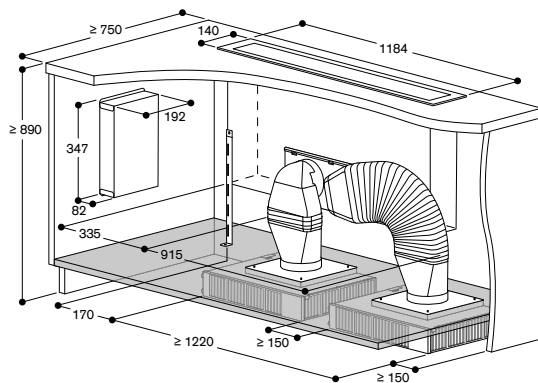

A: Surface mounting
B: Flush mounting

Not recommended for non-thermally insulated outer wall or floor ($U \geq 0.5 \text{ W/m}^2\text{K}$)

Measurements in mm

Planning example
AL 400 120cm with AR 400 142 (air extraction) -
Cellar installation - Metal

Good to know

- These installations in extraction with 2 remote fan units are not recommended for EU countries due to legislation EU 66/2014.
- Depending on the distance between the AL400 and the remote fan units you may need more flat and round ducts.

List of components

- 1 x AL 400 122
- 2 x AR 400 142 (remote fan unit)
- 1 x AD 854 050 (connecting piece to the bottom)
- 2 x AD 854 010 (flat duct, metal)
- 2 x AD 854 041 (flat duct adapter round, metal)
- 2 x or more AD 751 010 (aluflex pipe round)
- 1 x AD 990 091 (adhesive tape)

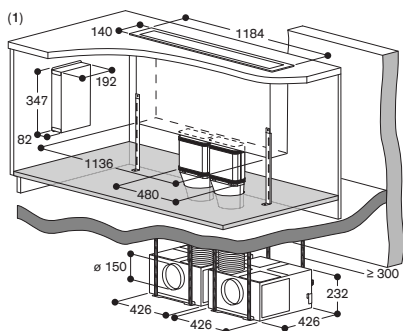

Planning example
AL 400 120cm with AR 401 142 (air extraction) -
Cellar installation with outside wall remote fan unit - Metal

List of components

- 1 x AL 400 122
- 2 x AR 401 142 (remote fan unit)
- 1 x AD 854 050 (connecting piece to the bottom)
- 2 x AD 854 010 (flat duct, metal)
- 2 x AD 854 041 (flat duct adapter round, metal)
- 2 x or more AD 751 010 (aluflex pipe round)
- 2 x AD 854 032 (flat duct adapter round 90°, metal)
- 2 x or more AD 854 010 (flat duct, metal)
- 2 x AD 854 041 (flat duct adapter round, metal)
- 1 x AD 751 010 (aluflex pipe round)
- 2 x AD 704 040 (pipe adapter DN200/150 round, metal)
- 2 x AD 702 052 (telescopic wall duct)
- 1 x AD 990 091 (adhesive tape)

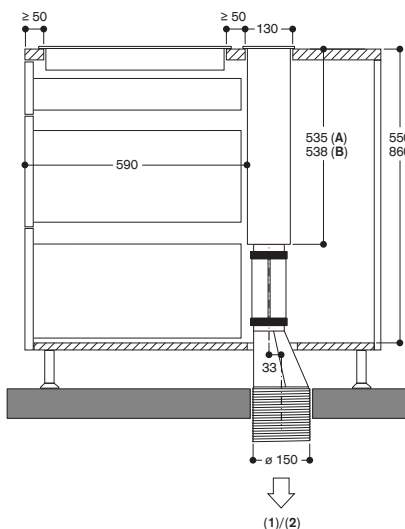
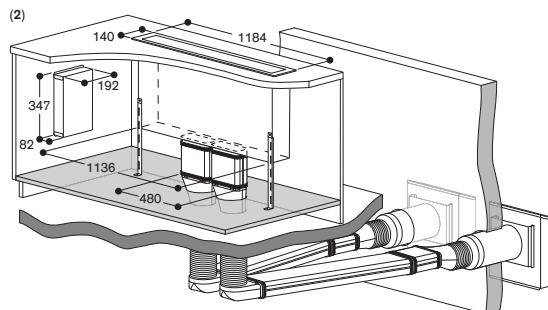

A: Surface mounting
 B: Flush mounting

Extraction mode with remote fan unit
 1: AR 400 142
 2: AR 401 142

Measurements in mm



AL 200 180
Gaggenau Black
Width 80 cm
Air extraction / Air recirculation



Necessary Installation accessories

AA 200 880
Air recirculation module including activated charcoal filters with highly efficient odour reduction and allergen deactivation.

AA 200 882
Regenerable air recirculation module including activated charcoal filters with highly efficient odour reduction. Regenerable in the oven at 200°C. Extended change interval of the activated charcoal filter: regenerable up to 30 times.

AA 200 900
Kit for surface mounted installation
AL 200

Including 2 trims, each 5 mm width
Gaggenau Black

AA 200 910
Installation kit for fan unit at a distance
(3m maximum)

VA 200 080
Installation kit for installation in a single
worktop cut-out

Installation accessories for air ducting
you will find at the pages 287 – 293.

Table ventilation 200 series

AL 200

- Extendable table ventilation, when not in use can be completely lowered into the worktop
- Perfect cooking and ventilation combination with frameless induction cooktops 80 cm wide for flush mounting in a single cut-out
- Transparent ventilation screen for discreet integration in the kitchen space
- Ambient lighting thru the glass edges
- Guided Air technology ensures high vapour catch rate across the whole cooktop

Output

Performance and noise level, output level 3/Intensive:

Air output according to EN61591.

Sound power level according to EN 60704-3.

Air extraction:

501 / 775 m³/h.

62 / 70 dB (A) re 1 pW.

Air recirculation:

447 / 562 m³/h.

65 / 70 dB(A) re 1 pW.

Features

White ambient lighting thru the glass edges, which can be changed to any color via the Home Connect App.

Automatic function with sensor-controlled run-on function.

3 electronically controlled power levels and 1 intensive mode.

Grease filter saturation indicator.

Activated charcoal filter saturation indicator.

2 large-scale metal grease filters included, easy to remove, dishwasher-safe.

Overflow capacity 170 ml in grease filter. Additional capacity 600 ml in the remote fan unit.

Activated charcoal filter easily removeable from above for air recirculation system.

Gaggenau Black anodized aluminium frame.

1 user interface to set the power levels and 1 user interface to control the Guided Air technology.

Fan technology with highly efficient, brushless DC motor (BLDC).

Flexible installation of the fan unit at the front (for a compact wall solution), at the back (without loss of drawer space), or at a distance from the appliance.

Selected digital services

(Home Connect)

Cooktop-based ventilation control (with suitable cooktop)

Remote control and monitoring

Remote diagnostics

Please read additional information on Home Connect on page 411.

Consumption data

Energy efficiency class A at a range of energy efficiency classes from A+++ to D.

Energy consumption 36.9 kWh/year.

Ventilation efficiency class A.

Illumination efficiency class -.

Grease filter efficiency class B.

Sound level min. 39 dB / max. 62 dB normal mode.

Planning notes

The equivalent ducting length to ensure good performance is L_{max} 28 m.

Compatible with frameless cooktops 400 series (CX 482) or 200 series (CI 282 / CI 283), in a single worktop cut-out, for flush mounting.

For installation in a single worktop cut-out the installation accessory VA 200 080 must be placed between the appliances. This includes a connection strip and furniture supports that ensure cabinet stability.

Compatible with induction cooktops 400 series (CX 482, VI 482) or 200 series (CI 282 / CI 283), in 2 separate cut-outs, for surface mounted installation.

For surface mounted installation the accessory AA 200 900 is required.

The table ventilation can be installed in the cabinet or between two (e.g. for an island installation deeper than 100 cm). Width of the cabinets 90 cm, 100 cm or 120 cm.

No upper cabinets should be installed above the table ventilation to maintain optimum performance.

The following distance should be observed:

- 65 cm from the table ventilation to open shelves
- 50 cm left and right of the table ventilation to the wall or neighbouring tall cabinets.
- 5 cm from the table ventilation frame to the wall.
- 2 cm from the Guided Air suction area to a cabinet wall.

Installation is possible in worktops made of stone, synthetics or solid wood. Heat resistance and watertight sealing of the cut edges must be observed. Concerning other materials please consult the worktop manufacturer. Worktop thickness recommended for flush installation in a single cut-out: minimum 16mm - maximum 45mm. The bearing capacity and stability, in the case of thinner worktops in particular, must be supported using suitable substructures. Take into account the appliance weight and additional loads.

Whatever installation situation, the fan unit should always be accessible. To install the fan unit at a distance, the installation kit AA 200 910 is required (with spare covers for closing air outlets). Maximum distance between the table ventilation and the fan unit 3 m.

In air extraction mode a one-way flap with a maximum opening pressure of 65 Pa should be installed.

In air extraction mode, always ensure adequate fresh air in the room if the appliance is being operated at the same time as a chimney-vented fireplace.

For optimum performance in air recirculation we recommend an outflow surface area of at least 400 cm².

For air recirculation an air recirculation module is required.

Special accessories (order as spare parts):
Part No. 17005381

Activated charcoal filters with highly efficient odour reduction and allergen deactivation.

Please read additional planning notes on page 246 – 247.

Connection

Total connected load 300 W.

Connecting cable 1.3 m, with plug.

Power consumption standby/
display off 0.4 W.

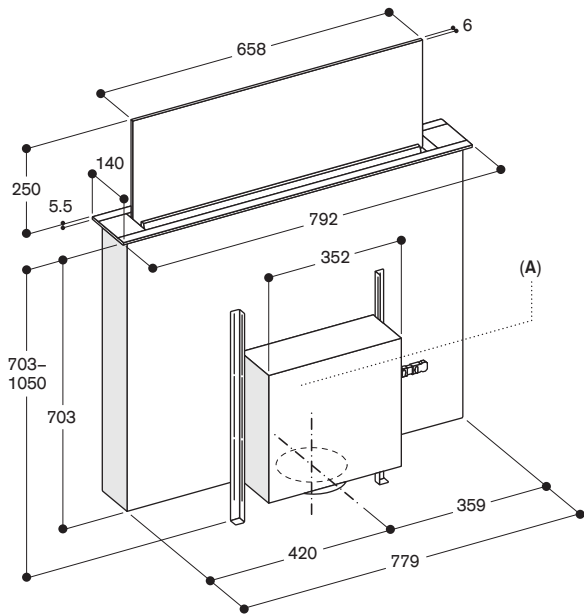

A: Flexible installation of the fan unit at the front, at the back or at a distance from the appliance (installation kit required - max. distance 3 m)

Fan unit must always be accessible

In recirculation: Not recommended for non-thermally insulated outer wall or floor ($U \geq 0.5 \text{ W/m}^2\text{K}$)

Measurements in mm

Planning example – Fan unit at the back

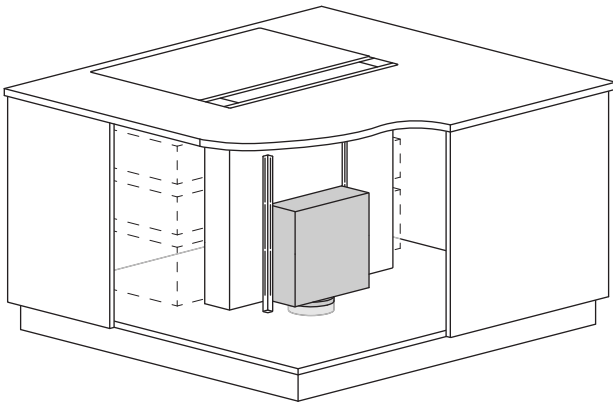

Planning example – Fan unit at the front

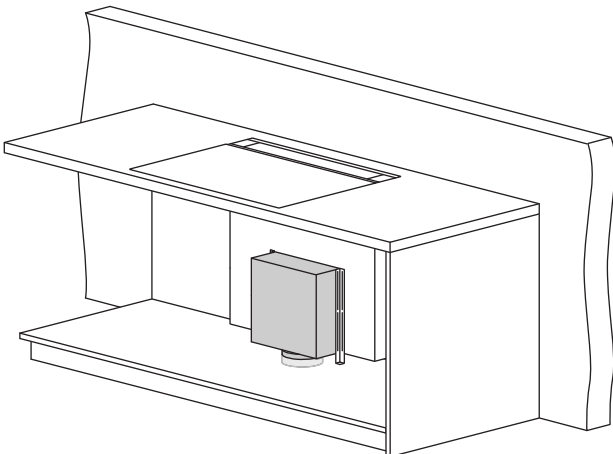

AL 200 180 with AA 200 910

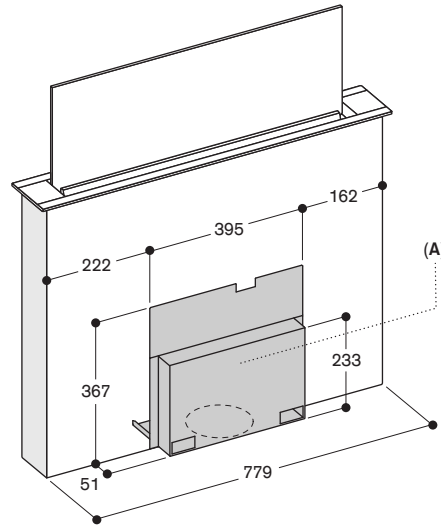

A: Access to the complete cover must be ensured even after installation

Cover can be installed on the front or the rear from the appliance

Measurements in mm

Planning example – Fan unit at a distance with AA 200 910

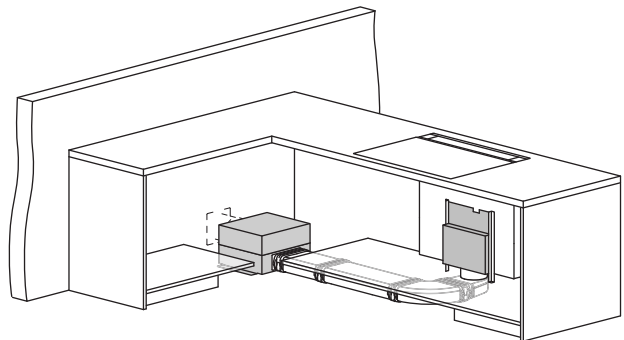

Combination with frameless induction cooktop in a single cut-out
 Flush installation

AL 200 180

Cooktops 400 series
 (CX 482)
 or 200 series
 (CI 282 / CI 283)

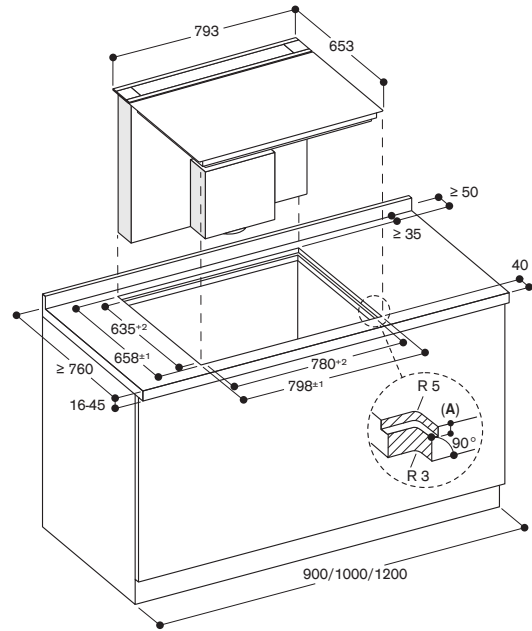

A: $6.5^{+0.5}$ mm
 Measurements in mm

Side view

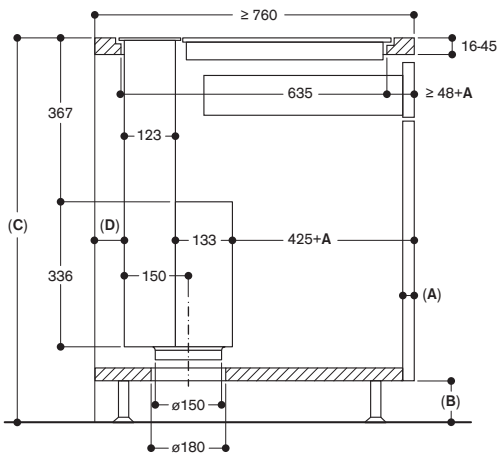

- A: Front thickness
- B: ≥ 60 mm for air recirculation
 ≥ 100 mm for air extraction with ducting in the plinth
- C: ≥ 850 mm for air extraction with ducting in the plinth
- D: ≥ 20 mm from the Guided Air suction area to a cabinet wall

Measurements in mm

View from above

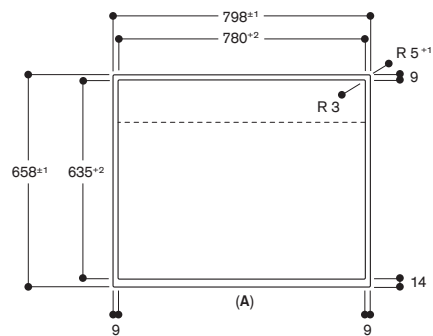

A: Front
 Measurements in mm

Cross section

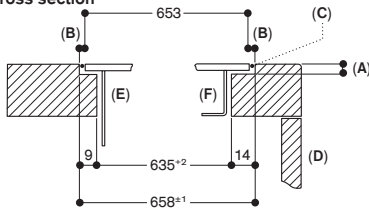

- A: $6.5^{+0.5}$ mm
- B: 2.5 mm
- C: Fill with silicone
- D: Front
- E: Table ventilation
- F: Induction cooktop

Measurements in mm

Longitudinal section

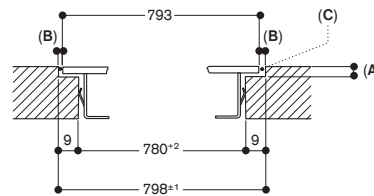

- A: $6.5^{+0.5}$ mm
- B: 2.5 mm
- C: Fill with silicone

Measurements in mm

AL 200 180

Cooktops 400 series
(CX 482, VI 482)
or 200 series
(CI 282 / CI 283)

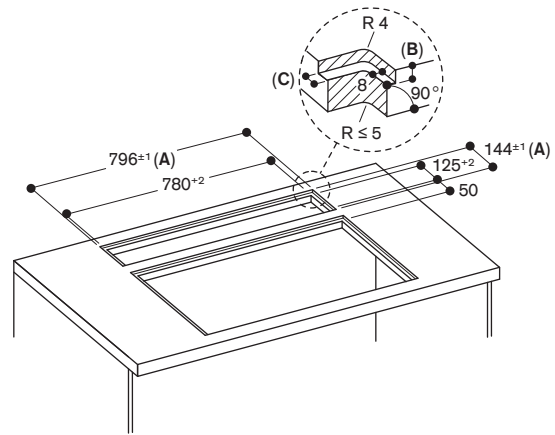

A: Incl. 2 mm silicone joint all around
B: 5.5 mm
C: 9.5 mm

Measurements in mm

AL 200 180

Cooktops 400 series
(CX 482, VI 482)
or 200 series
(CI 282 / CI 283)

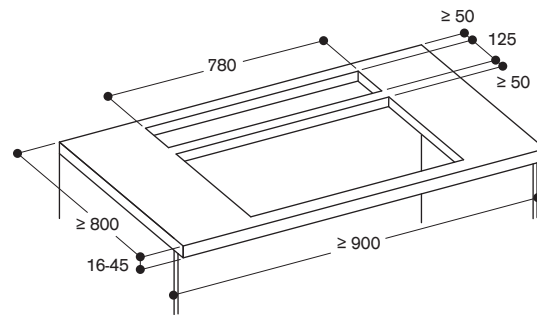

Measurements in mm

Side view

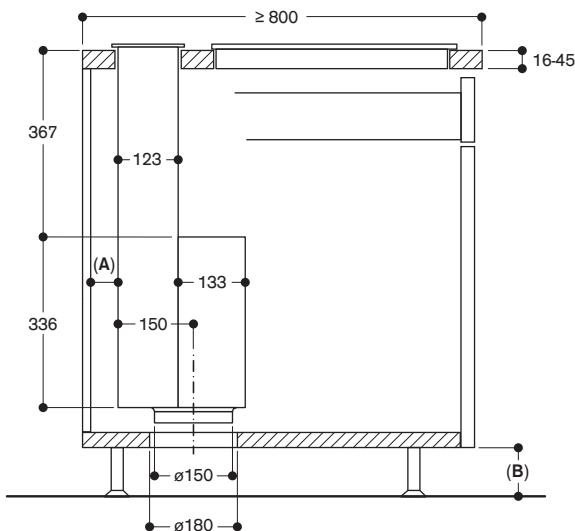

View from above

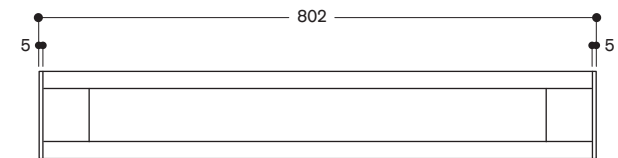

Measurements in mm

A: ≥ 20 mm from the Guided Air suction area to a unit wall
B: ≥ 60 mm for air recirculation
 ≥ 100 mm for air extraction with ducting in the plinth

Measurements in mm



AL 200 190
Gaggenau Black
Width 90 cm
Air extraction / Air recirculation



Necessary Installation accessories
AA 200 890

Air recirculation module including activated charcoal filters with highly efficient odour reduction and allergen deactivation.

AA 200 892

Regenerable air recirculation module including activated charcoal filters with highly efficient odour reduction. Regenerable in the oven at 200 °C. Extended change interval of the activated charcoal filter: regenerable up to 30 times.

AA 200 900

Kit for surface mounted installation AL 200

Including 2 trims, each 5 mm width Gaggenau Black

AA 200 910

Installation kit for fan unit at a distance (3m maximum)

VA 200 090

Installation kit for installation in a single worktop cut-out

Installation accessories for air ducting you will find at the pages 287 – 293.

Table ventilation 200 series

AL 200

- Extendable table ventilation, when not in use can be completely lowered into the worktop
- Perfect cooking and ventilation combination with frameless induction cooktops 90 cm wide for flush mounting in a single cut-out
- Transparent ventilation screen for discreet integration in the kitchen space
- Ambient lighting thru the glass edges
- Guided Air technology ensures high vapour catch rate across the whole cooktop

Output

Performance and noise level, output level 3/Intensive:

Air output according to EN 61591.

Sound power level according to EN 60704-3.

Air extraction:

519 / 833 m³/h.

62 / 71 dB (A) re 1 pW.

Air recirculation:

472 / 620 m³/h.

65 / 71 dB(A) re 1 pW.

Features

White ambient lighting thru the glass edges, which can be changed to any color via the Home Connect App.

Automatic function with sensor-controlled run-on function.

3 electronically controlled power levels and 1 intensive mode.

Grease filter saturation indicator.

Activated charcoal filter saturation indicator.

2 large-scale metal grease filters included, easy to remove, dishwasher-safe. Overflow capacity 170 ml in grease filter. Additional capacity 600 ml in the remote fan unit.

Activated charcoal filter easily removeable from above for air recirculation system.

Gaggenau Black anodized aluminium frame.

1 user interface to set the power levels and 1 user interface to control the Guided Air technology.

Fan technology with highly efficient, brushless DC motor (BLDC).

Flexible installation of the fan unit at the front (for a compact wall solution), at the back (without loss of drawer space), or at a distance from the appliance.

Selected digital services

(Home Connect)

Cooktop-based ventilation control (with suitable cooktop)

Remote control and monitoring

Remote diagnostics

Please read additional information on Home Connect on page 411.

Consumption data

Energy efficiency class A at a range of energy efficiency classes from A+++ to D.

Energy consumption 37.8 kWh/year.

Ventilation efficiency class A.

Illumination efficiency class -.

Grease filter efficiency class C.

Sound level min. 41 dB / max. 62 dB normal mode.

Planning notes

The equivalent ducting length to ensure good performance is Lmax 28 m.

Compatible with frameless cooktops 400 series (CX 492, VI 492) or 200 series (CI 292), in a single worktop cut-out, for flush mounting.

For installation in a single worktop cut-out the installation accessory

VA 200 090 must be placed between the appliances. This includes a connection strip and furniture supports that ensure cabinet stability.

Compatible with induction cooktops 400 series (CX 492, VI 492) or 200 series (CI 292), in 2 separate worktop cut-outs, for surface mounted installation.

For surface mounted installation the accessory AA 200 900 is required.

The table ventilation can be installed in the cabinet or between two (e.g. for an island installation deeper than 100 cm). Width of the cabinets 90 cm, 100 cm or 120 cm.

No upper cabinets should be installed above the table ventilation to maintain optimum performance.

The following distance should be observed:

- 65 cm from the table ventilation to open shelves
- 50 cm left and right of the table ventilation to the wall or neighbouring tall cabinets.
- 5 cm from the table ventilation frame to the wall.
- 2 cm from the Guided Air suction area to a cabinet wall.

Installation is possible in worktops made of stone, synthetics or solid wood. Heat resistance and watertight sealing of the cut edges must be observed. Concerning other materials please consult the worktop manufacturer.

Worktop thickness recommended for flush installation in a single cut-out: minimum 16 mm (with CX 492), 30 mm (with VI 492) - maximum 45mm.

The bearing capacity and stability, in the case of thinner worktops in particular, must be supported using suitable substructures. Take into account the appliance weight and additional loads.

Whatever installation situation, the fan unit should always be accessible.

To install the fan unit at a distance, the installation kit AA 200 910 is required (with spare covers for closing air outlets). Maximum distance between the table ventilation and the fan unit 3 m.

In air extraction mode a one-way flap with a maximum opening pressure of 65 Pa should be installed.

In air extraction mode, always ensure adequate fresh air in the room if the appliance is being operated at the same time as a chimney-vented fireplace.

For optimum performance in air recirculation we recommend an outflow surface area of at least 400 cm².

For air recirculation an air recirculation module is required.

Special accessories (order as spare parts): Part No. 17005381

Activated charcoal filters with highly efficient odour reduction and allergen deactivation.

Please read additional planning notes on page 250 – 253.

Connection

Total connected load 300 W.

Connecting cable 1.3 m, with plug.

Power consumption standby/ display off 0.4 W.

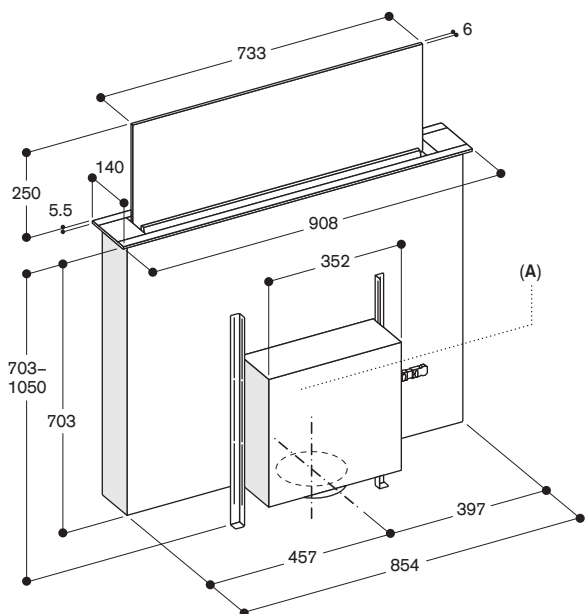

A: Flexible installation of the fan unit at the front, at the back or at a distance from the appliance (installation kit required - max. distance 3 m)

Fan unit must always be accessible

In recirculation: Not recommended for non-thermally insulated outer wall or floor ($U \geq 0.5 \text{ W/m}^2\text{K}$)

Measurements in mm

Planning example – Fan unit at the back

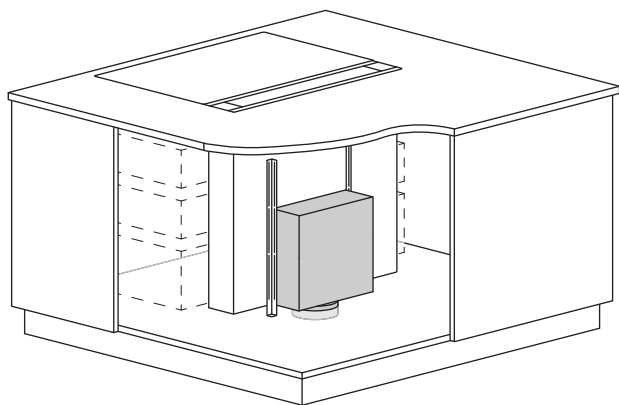

Planning example – Fan unit at the front

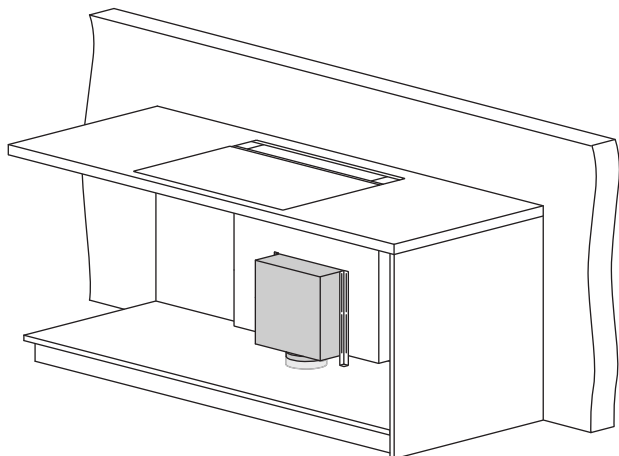

AL 200 190 with AA 200 910

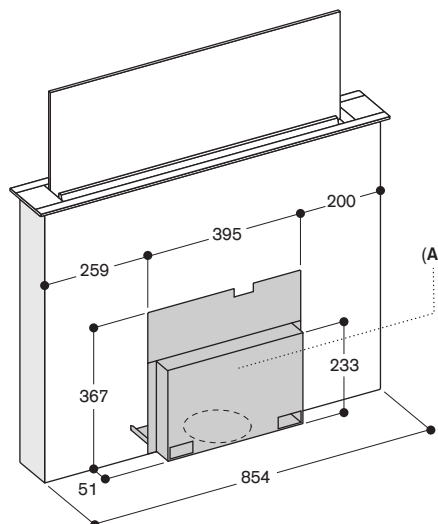

A: Access to the complete cover must be ensured even after installation

Cover can be installed on the front or the rear from the appliance

Measurements in mm

Measurements in mm

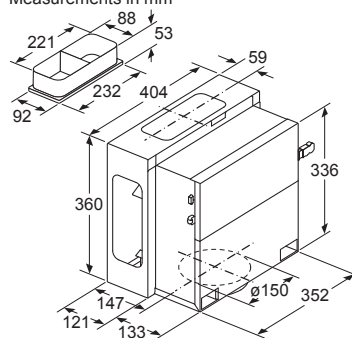

Planning example – Fan unit at a distance with AA 200 910

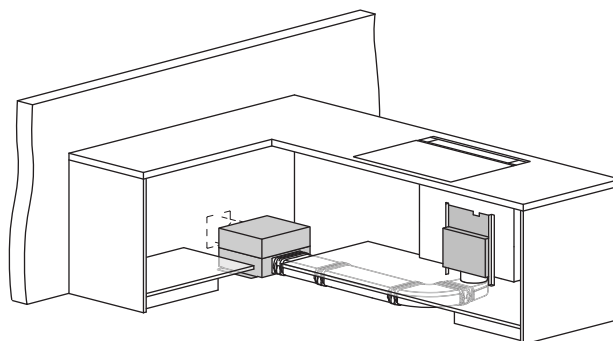

Combination with frameless induction cooktop in a single cut-out
 Flush installation

AL 200 190

Cooktops 400 series
 (CX 492)
 or 200 series (CI 292)

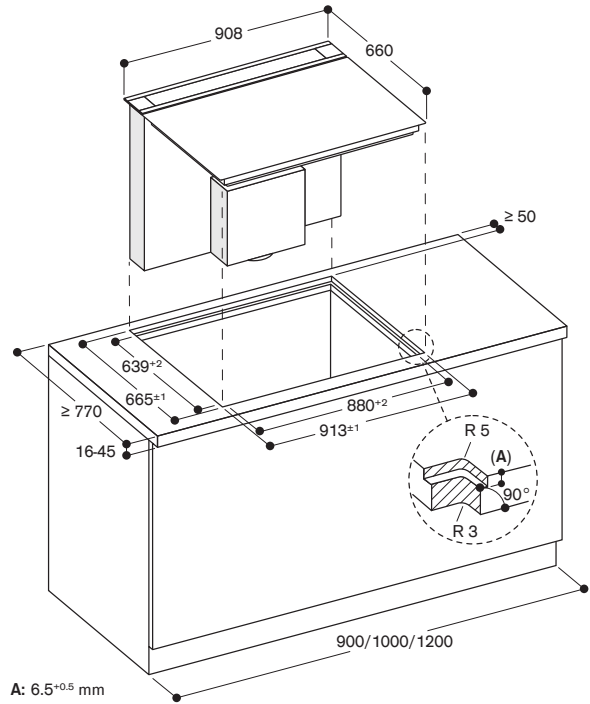

A: $6.5^{+0.5}$ mm
 Measurements in mm

Side view

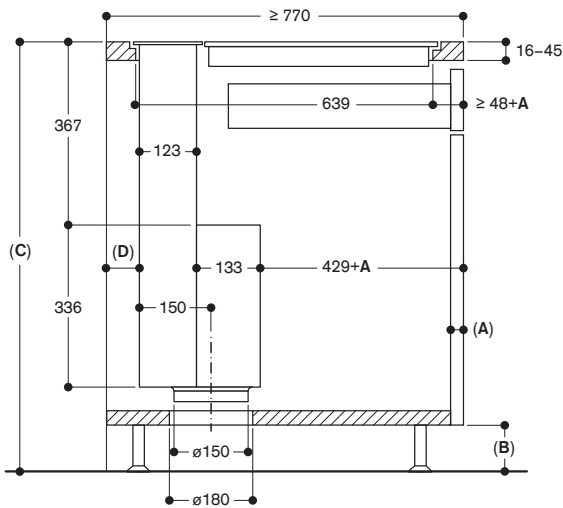

A: Front thickness
 B: ≥ 60 mm for air recirculation
 ≥ 100 mm for air extraction with ducting in the plinth
 C: ≥ 850 mm for air extraction with ducting in the plinth
 D: ≥ 20 mm from the Guided Air suction area to a cabinet wall
 Measurements in mm

View from above

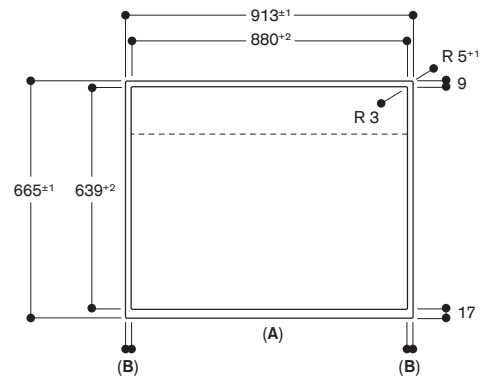

A: Front
 B: 16.5 mm
 Measurements in mm

Cross section

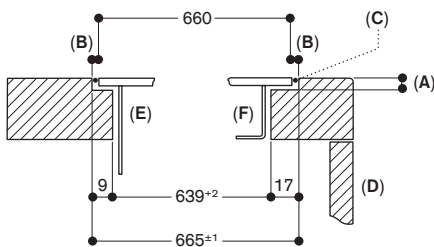

A: $6.5^{+0.5}$ mm
 B: 2.5 mm
 C: Fill with silicone
 D: Front
 E: Table ventilation
 F: Induction cooktop
 Measurements in mm

Longitudinal section

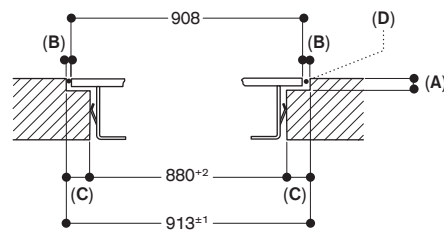

A: $6.5^{+0.5}$ mm
 B: 2.5 mm
 C: 16.5 mm
 D: Fill with silicone
 Measurements in mm

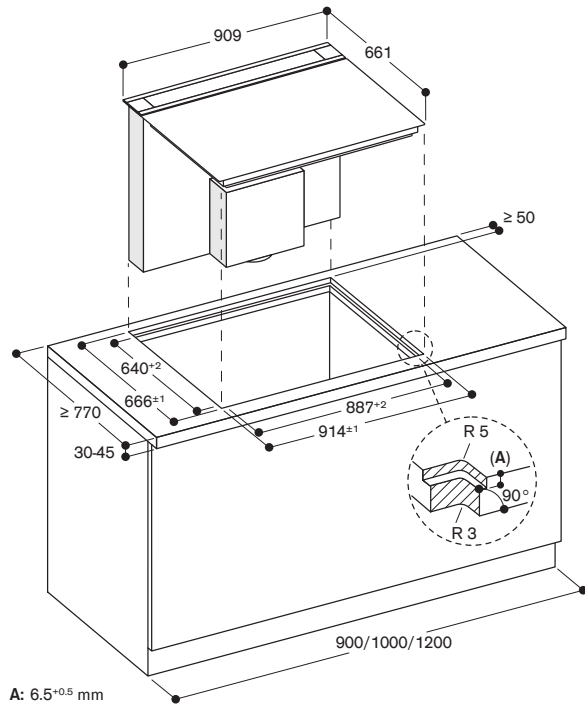
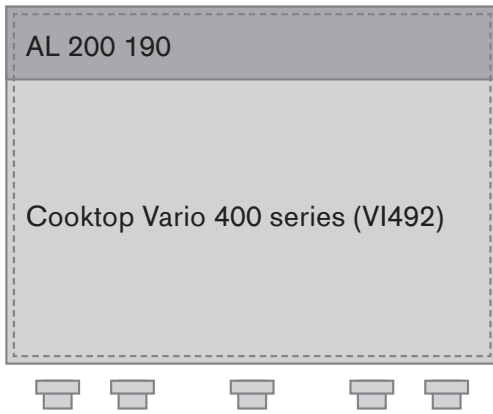

A: $6.5^{+0.5}$ mm

Measurements in mm

Side view

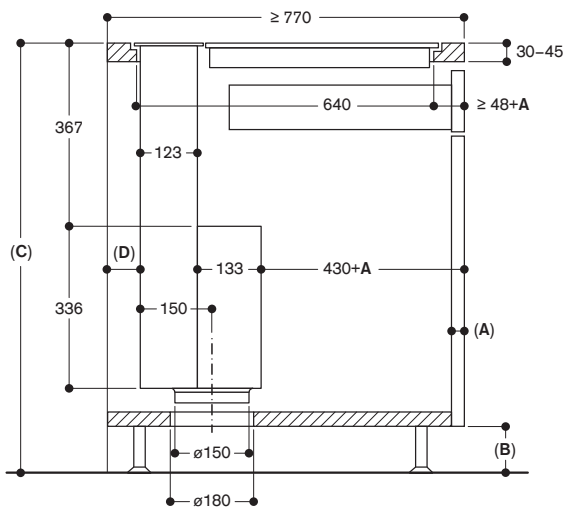

A: Front thickness
B: ≥ 60 mm for air recirculation
 ≥ 100 mm for air extraction with ducting in the plinth
C: ≥ 850 mm for air extraction with ducting in the plinth
D: ≥ 20 mm from the Guided Air suction area to a cabinet wall
Measurements in mm

View from above

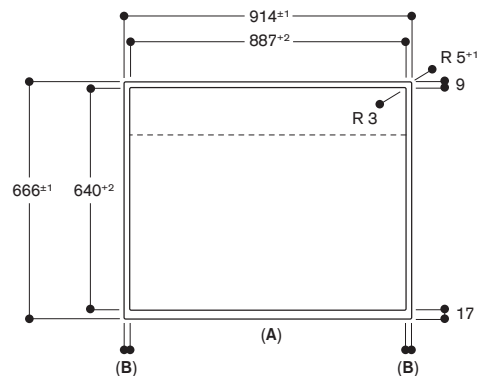

A: Front
B: 13.5 mm

Measurements in mm

Cross section

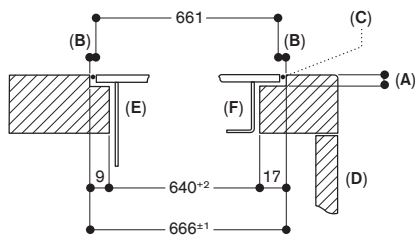

A: $6.5^{+0.5}$ mm
B: 2.5 mm
C: Fill with silicone
D: Front
E: Table ventilation
F: Induction cooktop
Measurements in mm

Longitudinal section

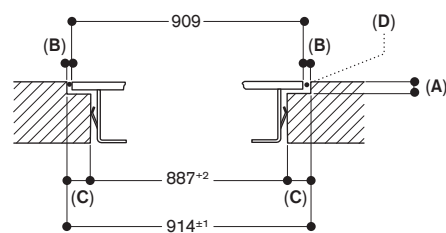

A: $6.5^{+0.5}$ mm
B: 2.5 mm
C: 13.5 mm
D: Fill with silicone
Measurements in mm

Combination with frameless induction cooktops in 2 separate cut-outs

Flush installation

AL 200 190

Cooktops 400 series
(CX 492, VI 492)
or 200 series (CI 292)

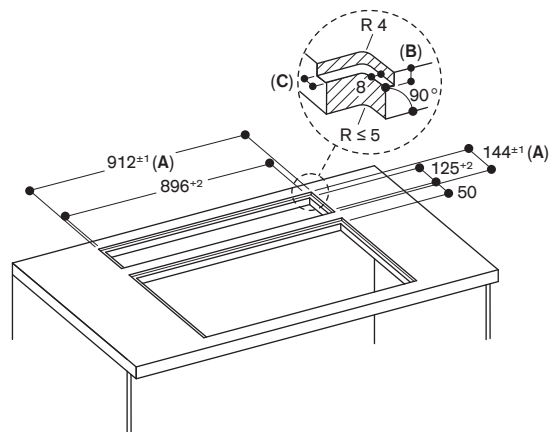

A: Incl. 2 mm silicone joint all around
B: 5.5 mm
C: 9.5 mm

Measurements in mm

Combination with induction cooktop in 2 separate cut-outs

Surface installation

AL 200 190

Cooktops 400 series
(CX 492, VI 492)
or 200 series (CI 292)

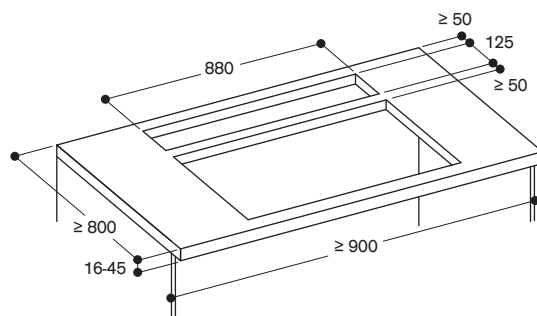

Measurements in mm

Side view

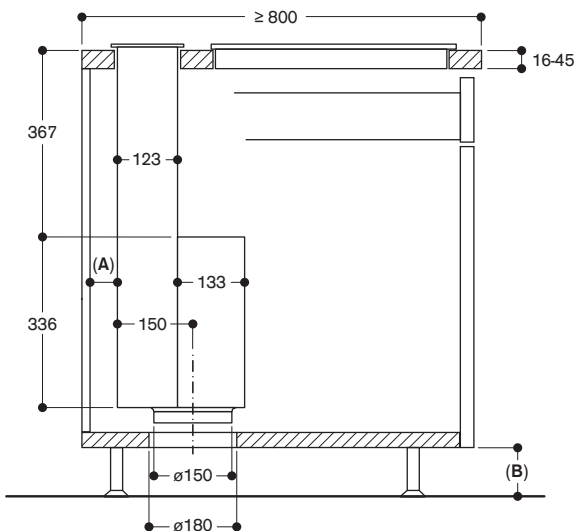

View from above

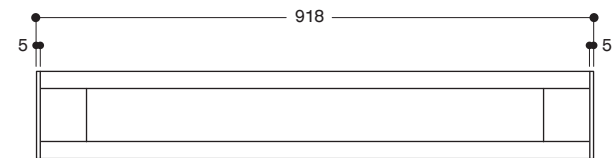

Measurements in mm

A: ≥ 20 mm from the Guided Air suction area to a unit wall
B: ≥ 60 mm for air recirculation
≥ 100 mm for air extraction with ducting in the plinth

Measurements in mm

AL 200 180

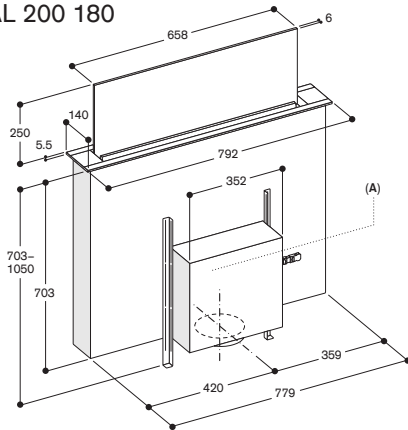

A: Flexible installation of the fan unit at the front, at the back or at a distance from the appliance (installation kit required - max. distance 3 m)

Fan unit must always be accessible

In recirculation: Not recommended for non-thermally insulated outer wall or floor ($U \geq 0.5 \text{ W/m}^2\text{K}$)

Measurements in mm

Flush installation

Combination with frameless induction cooktops in a single cut-out

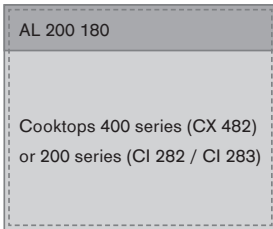

For cut-out dimensions, see page 246

Installation accessory	Installation kit VA 200 080
------------------------	-----------------------------

Combination with frameless induction cooktops in 2 separate cut-outs

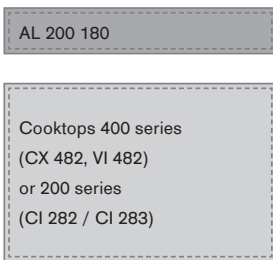

For cut-out dimensions, see page 247

Installation accessory	-
------------------------	---

Surface installation

Combination with induction cooktop in 2 separate cut-outs

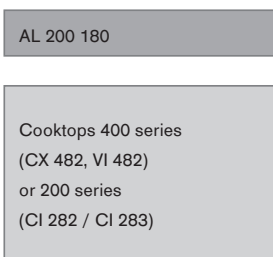

For cut-out dimensions, see page 247

Installation accessory	Installation kit AA 200 900
------------------------	-----------------------------

AL 200 190

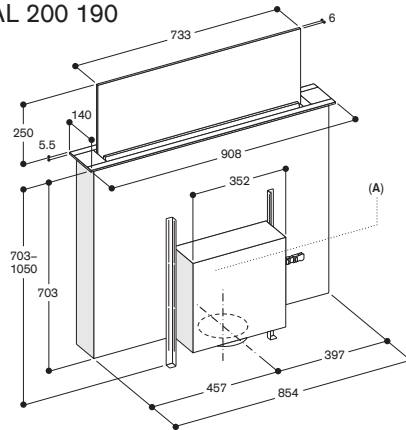

A: Flexible installation of the fan unit at the front, at the back or at a distance from the appliance (installation kit required - max. distance 3 m)

Fan unit must always be accessible

In recirculation: Not recommended for non-thermally insulated outer wall or floor ($U \geq 0.5 \text{ W/m}^2\text{K}$)

Measurements in mm

Flush installation

Combination with frameless induction cooktops in a single cut-out

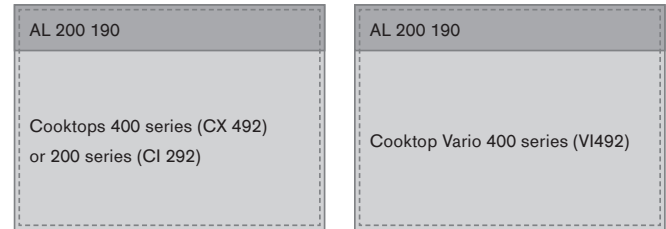

For cut-out dimensions, see page 250

For cut-out dimensions, see page 251

Installation accessory	Installation kit VA 200 090	Installation kit VA 200 090
------------------------	-----------------------------	-----------------------------

Combination with frameless induction cooktops in 2 separate cut-outs

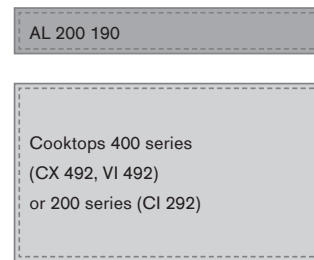

For cut-out dimensions, see page 252

Installation accessory	-
------------------------	---

Surface installation

Combination with induction cooktop in 2 separate cut-outs

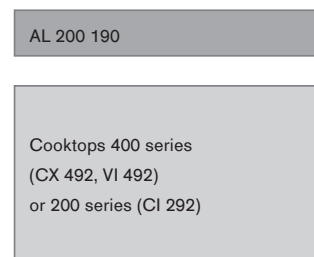

For cut-out dimensions, see page 252

Installation accessory	Installation kit AA 200 900
------------------------	-----------------------------



VL 414 115
 stainless steel
 Width 15.5 cm
 Air extraction / Air recirculation
 Motorless
 Knob needs to be ordered separately



Necessary installation accessories

CKV 410 010
 Stainless steel knob 400 series
 for VL 414
 Electronic control
 Set of 1 knob

CKV 410 000
 Black knob 400 series for VL 414
 Electronic control
 Set of 1 knob

In combination with remote fan units

AR 400 142
 AR 401 142
 AR 403 122
 AR 413 122
 AR 410 110

Installation accessories

AD 410 040
 Flexibel connecting piece
 DN 150 flat

AD 851 041
 Connecting piece for extension with
 flat duct DN 150 for extra deep worktop

VA 420 004
 Connection strip for combination with
 other Vario appliances of the 400 series
 for flush mounting

VA 420 010
 Connection strip for combination with
 other Vario appliances of the 400 series
 for surface mounting

Special accessories

AA 400 510
 Window contact switch

AA 414 010
 Ventilation moulding for VL 414 next to
 gas appliance.

Installation accessories for air ducting
 you will find at the pages 287 – 293.

Vario downdraft ventilation 400 series VL 414

- Highly efficient, low noise ventilation system especially with remote fan unit AR 410 110
- Function for automatic, sensor-controlled power adjustment depending on the build-up of cooking vapours
- Minimal planning and easy installation
- Solid stainless steel knob, also selectable with black robust finishing, for precise control and personalisation
- Precision crafted 3 mm stainless steel
- For surface mounting with a visible edge or for flush mounting
- Can be combined perfectly with other Vario appliances of the 400 series

Output

Power levels depend on the remote fan unit.

Refer to the "Technical specifications" of the hood for the matching remote fan units for air recirculation or air extraction mode.

Features

Control knob with illuminated ring.
 3 electronically controlled power levels and 1 intensive mode.

Automatic sensor-controlled performance adjustment of the ventilation system.

Automatic sensor controlled or manual run on function.

Large-scale metal grease filter with high grease absorption.

Removable, dishwasher-safe grease filter unit.

Grease filter and activated charcoal filter saturation indicator.

Airflow-optimised interior for efficient air circulation.

Interval ventilation, 6 min.

Enamelled ventilation grille, dishwasher-safe.

Air exhaust bend included in delivery.
 Overflow 250 ml capacity.

Selected digital services (Home Connect)

Cooktop-based ventilation control (with suitable cooktop)
 Remote control and monitoring
 Remote diagnostics

Please read additional information on Home Connect on page 411.

Consumption data

Consumption data is referred to a configuration with the remote fan unit AR 403 122.

Energy efficiency class A+ at a range of energy efficiency classes from A+++ to D.

Energy consumption 40.4 kWh/year.

Ventilation efficiency class A.

Illumination efficiency class -.

Grease filter efficiency class B.

Sound level min. 57 dB / max. 71 dB normal mode.

Planning notes

The equivalent ducting length to ensure good performance is Lmax 26 m.
 For each VL one remote fan unit is recommended.

Maximum cooktop(s) width between two VL: 80 cm except with the CX 482.
 Vario cooktops like Vario electric grill and Vario gas wok should be placed between 2 VL.

In case of Vario electric grill, recirculation is not recommended.
 If operated next to gas appliances, the ventilation moulding AA 414 010 is recommended to ensure maximum performance of the cooktop.

Appliance can be snapped into the worktop from above.

Depending on the type of installation (surface-mounted or flush-mounted), the specific location of the cut-out and the knob positions may vary.

If combining several Vario appliances of the 400 series, a connection strip VA 420 must be placed between the appliances. Depending on the type of installation, the corresponding connection strip must be provided.

The bearing capacity and stability, in the case of thin worktops in particular, must be supported using suitable substructures. Take into account the appliance weight and additional loads.

Additional instructions for flush mounting:

Installation is possible in worktops made of stone, synthetics or solid wood. Heat resistance and watertight sealing of the cut edges must be observed. Concerning other materials please consult the worktop manufacturer. The groove must be continuous and even, so that uniform placing of the appliance on the gasket is ensured. Do not use discontinuous lining.

The joint width may vary due to size tolerances of the combinations and of the worktop cut-out.

When installing a ventilation hood with air extraction mode and a chimney-vented fireplace, the power supply line of the ventilation appliance needs a suitable safety switch.

Please read additional planning notes on page 256 – 259.

Connection

Total connected load 10 W.
 Connecting cable 1.75 m, pluggable.
 Connecting cables 0.3m and 1 m for control knobs.
 Plan a LAN cable.

*Energy efficiency class: at a range of energy efficiency classes from A+++ to D.

**Installation of the downdraft ventilation;
surface mounting**

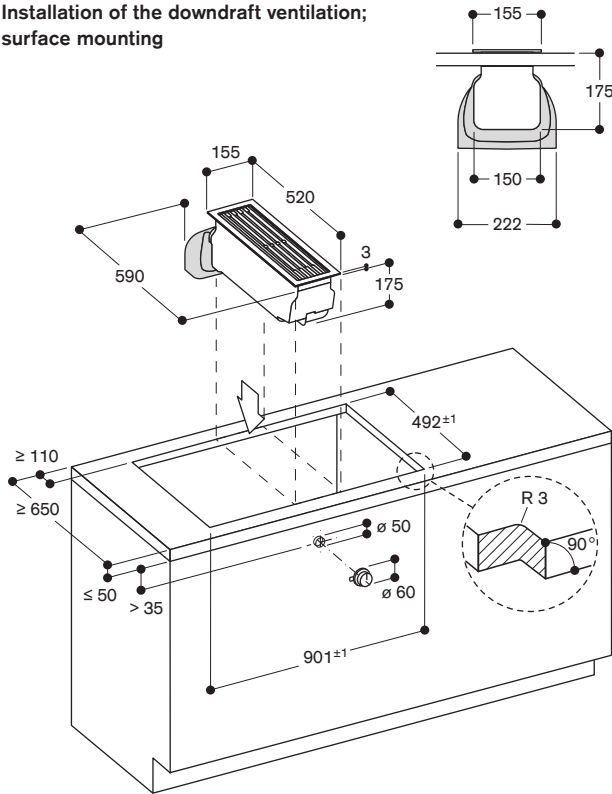

measurements in mm

Installation of the control knob

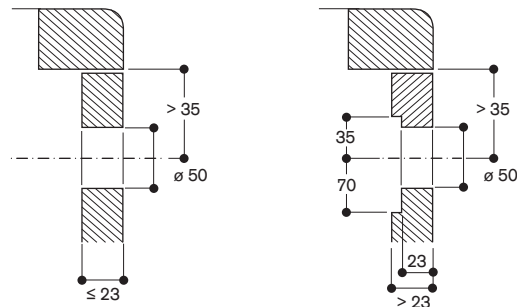

measurements in mm

**Installation of the downdraft ventilation;
flush mounting**

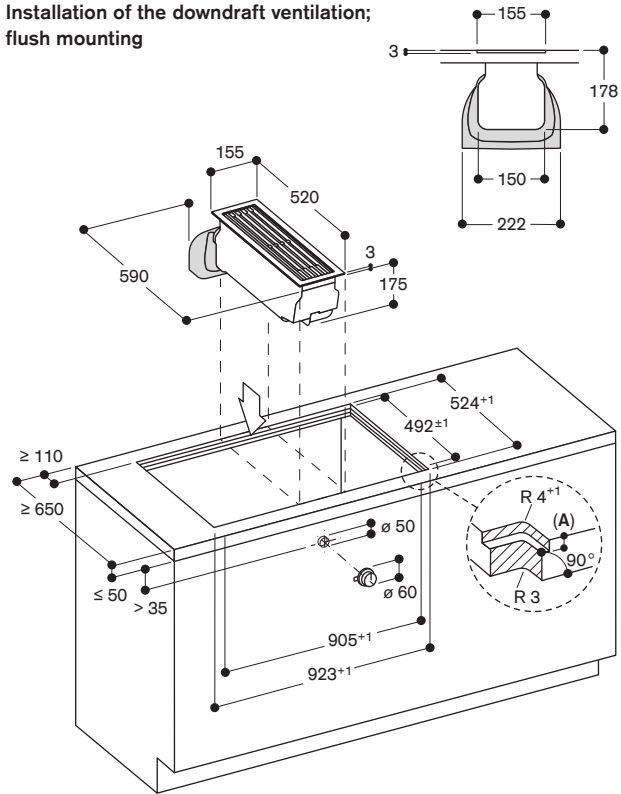

A: 3.5^{+0.5} in combination with at least one framed appliance
6.5^{+0.5} in combination with at least one frameless induction cooktop

measurements in mm

Installation of the control knob

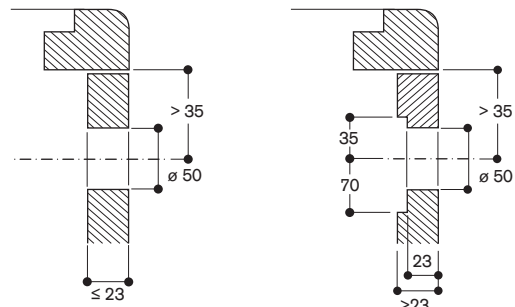

measurements in mm

Installation accessories

AD 410 040 : Flexibel connecting piece, DN 150 flat

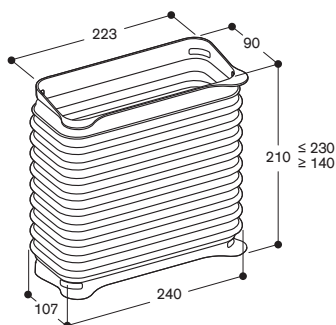

measurements in mm

AD 851 041: Connecting piece VL for extension with flat duct DN150 for extra deep worktop

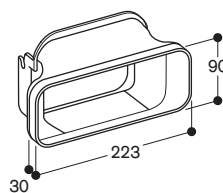

Recommended configurations for the Vario downdraft ventilation 400 series

Good to know – for correct planning and installation

- For depth measurements, take account of the depth of the furniture cavity and worktop overhangs of the kitchen furniture.
- It is also important that ducting is well sealed in order to prevent air leaks, e.g. by using the adequate adhesive tape or using the adequate connecting piece.
- Vario cooktops like Vario electric grill or Vario gas wok should be placed between 2 VL.
- In case of Vario electric grill air recirculation is not recommended.
- With the Vario downdraft ventilation, the ducting can be connected straight down (1) or to the rear using additional connecting pieces (2) and (3). These are available as special accessories, see below.

For the total overall dimensions in the furniture, please also take into account the individual dimensions and position of the ducts and the remote fan unit.

The remote fan unit can be turned in all directions, depending on the desired direction for the exhaust air or filter removal.

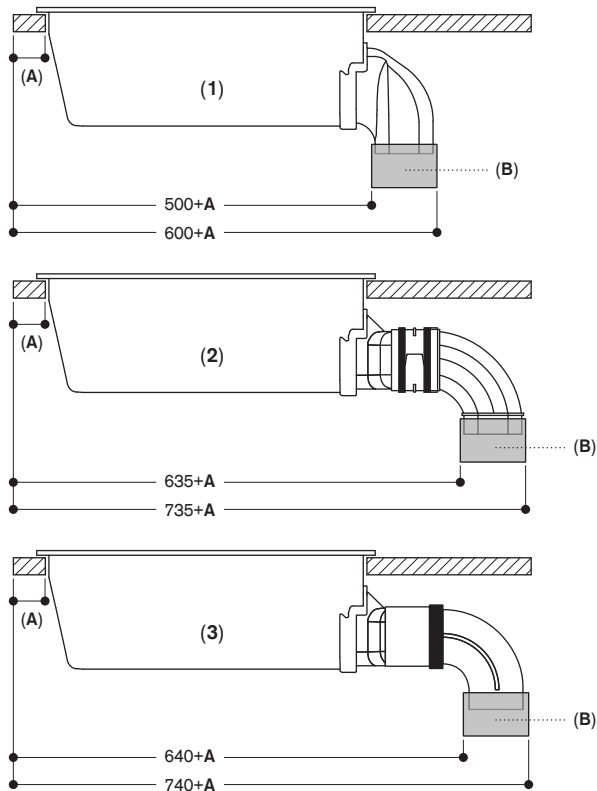

- 1: Direct installation
- 2: Installation with extension for extra deep worktop and plastic ducting:
 - AD 851 041 (Connecting piece for extension)
 - AD 857 040 (Flat duct connecting piece, plastic)
 - AD 857 030 (Flat duct bend 90° vertical, plastic)
- 3: Installation with extension for extra deep worktop and metal ducting:
 - AD 851 041 (Connecting piece for extension)
 - AD 854 000 (Flat duct connecting piece, metal)
 - AD 854 030 (Flat duct bend 90° vertical, metal)

A: ≥ 50mm

B: Connecting piece

measurements in mm

Planning example (air recirculation) - Direct installation
VL414 with AR 410 110 remote fan unit

Good to know

- Wall installation, worktop depth 65 cm
- Allow accessibility to the charcoal filters in the lower cabinet for their replacement. Additionally, if the plinth is higher than 80 mm, the external remote fan unit has to be elevated to enable access to the filters. If the plinth is 80 mm high, the remote fan unit can be placed directly on the floor.
- For optimum performance, the recirculated air requires sufficient space to escape (outflow surface area of at least 400 cm²).

List of components

- 1 x VL 414 115 Vario downdraft ventilation
- 1 x CKV 410 010 Stainless steel knob or 1 x CKV 410 000 Black knob
- 1 x AR 410 110 (remote fan unit air recirculation)
- 1 x AD 410 040 (flexibel connecting piece)

Order as set (appliances and accessories):

- SET1VL4711 with Stainless steel knob**
- SET1VL4721 with Black knob**

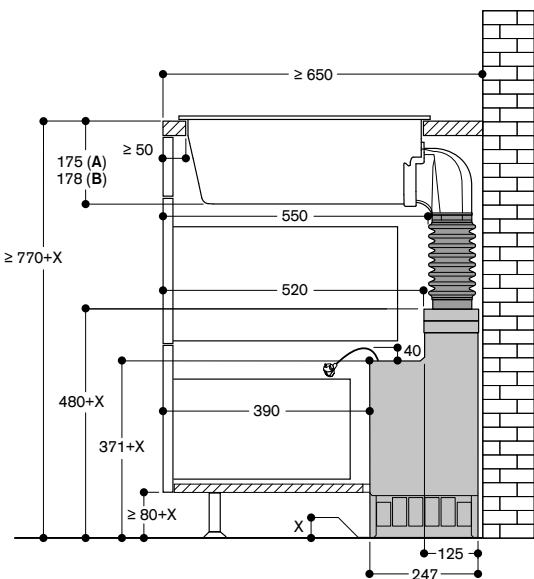
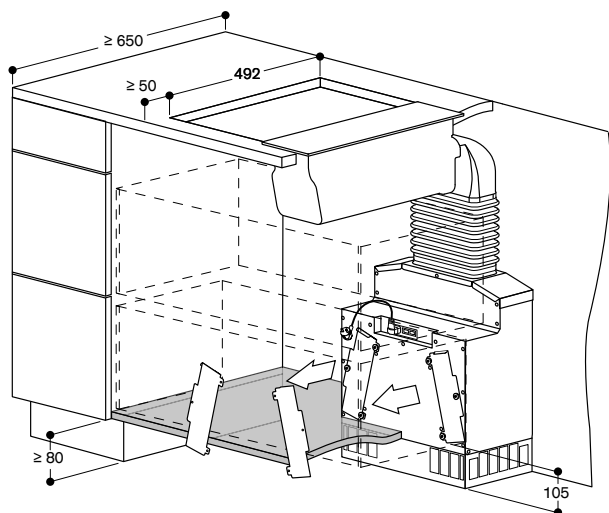

- A:** Surface mounting
- B:** Flush mounting (only VL 414)

Not recommended for non-thermally insulated outer wall or floor ($U \geq 0.5 \text{ W/m}^2\text{K}$)

Measurements in mm

Planning example (air recirculation) - Direct installation
VL414 with AR 413 122 remote fan unit

Good to know

- Wall or island installation.
- Allow accessibility to the charcoal filters in the lower cabinet for their replacement.
- The recommended minimum distance between filter openings and cupboard wall if there is no ventilation grille directly in front: 15 cm.
- For optimum performance, the recirculated air requires sufficient space to escape (outflow surface area of at least 400 cm²).

List of components

- 1 x VL 414 115 Vario downdraft ventilation
- 1 x CKV 410 010 Stainless steel knob or 1 x CKV 410 000 Black knob
- 1 x AR 413 122 (remote fan unit air recirculation)
- 1 x AD 410 040 (flat flexible connecting piece)
- 1 x AD 857 015 (flat duct 50 cm)
- 1 x AD 857 040 (flat duct connecting piece)
- 1 x AD 857 041 (flat duct adapter round)
- 1 x AD 990 090 (adhesive tape)

Order as set (appliances and accessories):

- SET1VL4712 with Stainless steel knob**
- SET1VL4722 with Black knob**

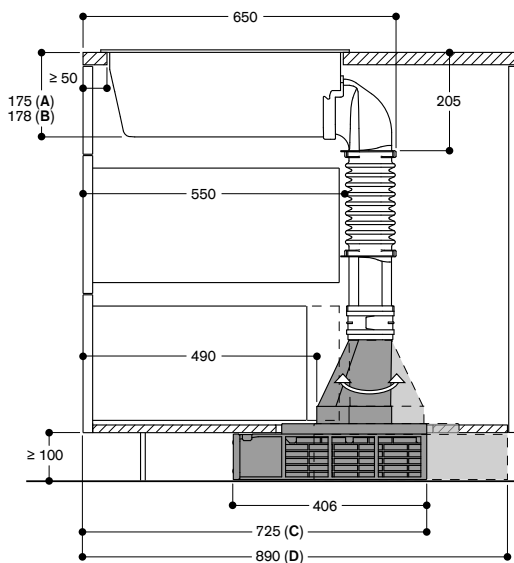
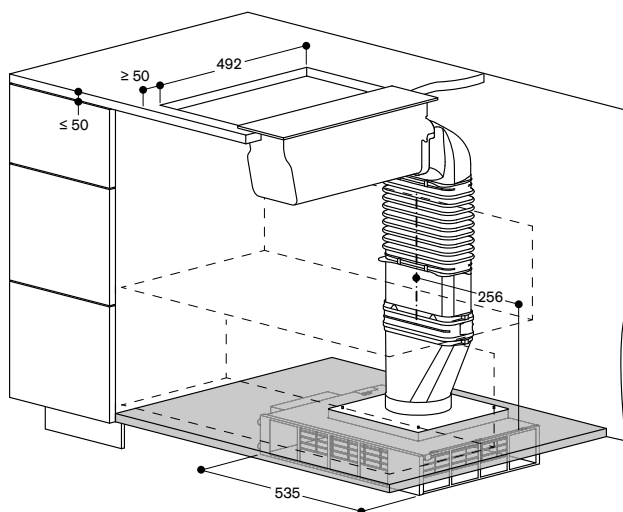

- A:** Surface mounting
- B:** Flush mounting (only VL 414)
- C:** Filter access from the front
Connecting piece flat/round towards the front
- D:** Filter access from the back
Connecting piece flat/round towards the back

Not recommended for non-thermally insulated floor ($U \geq 0.5 \text{ W/m}^2\text{K}$)

Measurements in mm

Recommended configurations for the Vario downdraft ventilation 400 series

Planning example (air extraction) - Direct installation VL414 with extraction remote fan unit - Cellar installation

Combination with AR 403 122 / AR 400 142 / AR 401 142

List of components

- 1 x VL 414 115 Vario downdraft ventilation
- 1 x CKV 410 010 Stainless steel knob or 1 x CKV 410 000 Black knob
- 1 x AD 410 040 (flat flexible connecting piece)
- 1 x AD 857 015 (flat duct 50 cm)
- 1 x AD 857 040 (flat duct connecting piece)
- 1 x AD 857 041 (flat duct adapter round)
- 1 x AR 403 122 or AR 400 142 or AR 401 142 (remote fan unit air extraction)

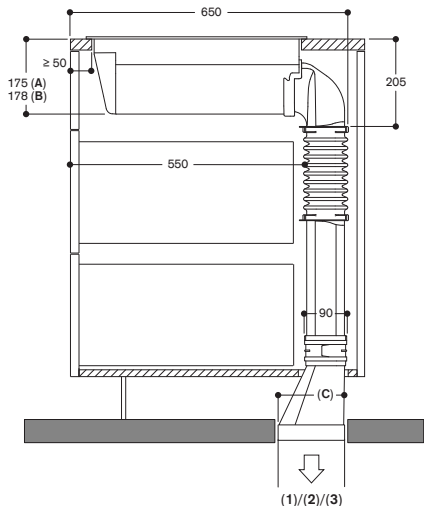
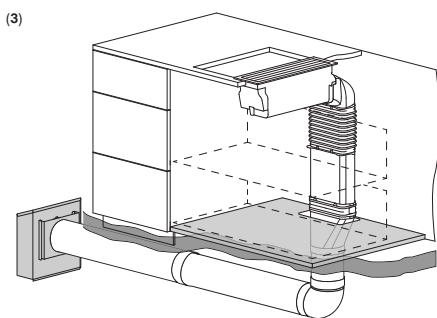
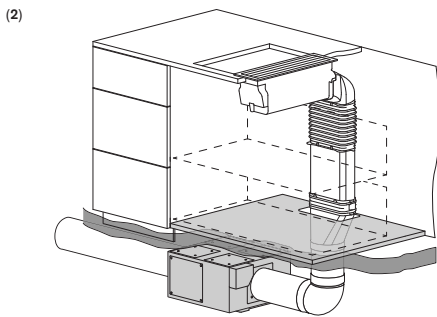
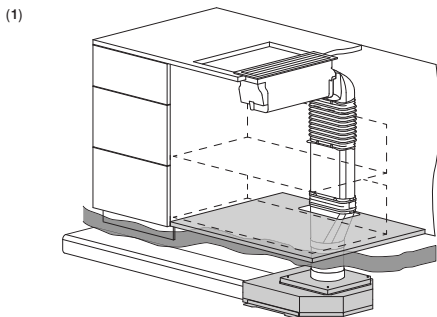

Extraction mode with remote fan unit
1: AR 403
2: AR 400
3: AR 401

A: Surface mounting
B: Flush mounting
C: 152.5

measurements in mm

Planning example (air extraction) - Direct installation - Metal VL 414 with AR 403 122 remote fan unit

Island installation, connection from the right side. Connection also possible to the left side, please be aware that the measures will be different.

List of components

- 1 x VL 414 115 Vario downdraft ventilation
- 1 x CKV 410 010 Stainless steel knob or 1 x CKV 410 000 Black knob
- 1 x AR 403 122 (remote fan unit air extraction)
- 1 x AD 858 010 (flat duct flex pipe, metal, DN 150)
- 1 x AD 854 041 (flat duct adapter round, metal, DN 150 flat/round)
- 1 x AD 990 091 (adhesive tape for sealing the ducts, aluminum)

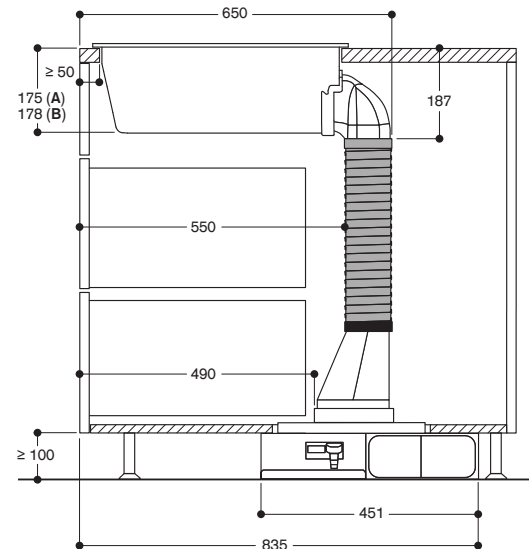
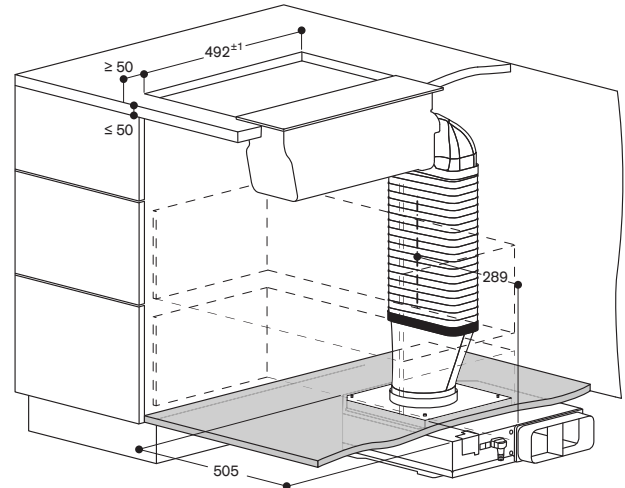

A: Surface mounting
B: Flush mounting (only VL414)

measurements in mm

**Planning example (air extraction) – Direct installation
VL 414 with AR 403 122 remote fan unit**

Island installation, connection to the right or the left side.

List of components

- 1 x VL 414 115 Vario downdraft ventilation
- 1 x CKV 410 010 Stainless steel knob or 1 x CKV 410 000 Black knob
- 1 x AR 403 122 (remote fan unit air extraction)
- 1 x AD 410 040 (flat flexible connecting piece)
- 1 x AD 857 015 (flat duct 50 cm)
- 1 x AD 857 040 (flat duct connecting piece)
- 1 x AD 857 041 (flat duct adapter round)
- 1 x AD 990 090 (adhesive tape)

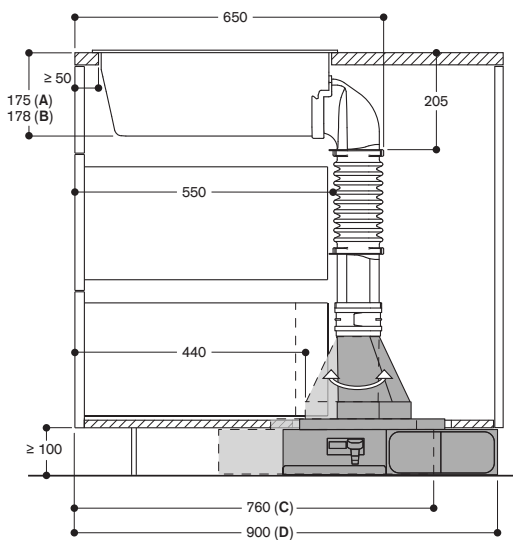
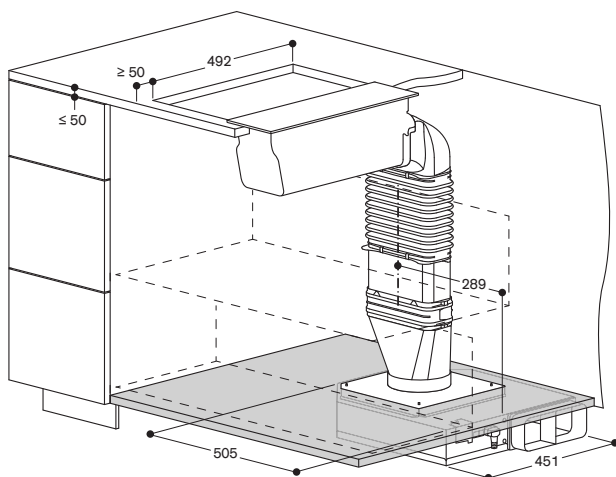

A: Surface mounting
 B: Flush mounting (only VL414)
 C: Exhaust to the left. Connecting piece flat/round towards the front
 D: Exhaust to the right. Connecting piece flat/round towards the back

measurements in mm

**Planning example (air recirculation) - with extension
VL 414 with AR 410 110 remote fan unit**

Good to know

- Allow accessibility to the charcoal filters in the lower cabinet for their replacement. Additionally, if the plinth is higher than 80 mm, the external remote fan unit has to be elevated to enable access to the filters. If the plinth is 80 mm high, the remote fan unit can be placed directly on the floor.
- For optimum performance, the recirculated air requires sufficient space to escape (outflow surface area of at least 400 cm²).
- Please note, this installation is also possible with Gaggenau plastic ducts

List of components - Metal

- 1 x VL 414 115 Vario downdraft ventilation
- 1 x CKV 410 010 Stainless steel knob or 1 x CKV 410 000 Black knob
- 1 x AR 410 110 (remote fan unit air recirculation)
- 1 x AD 851 041 (connection piece for extension)
- 1 x AD 854 000 (flat duct connecting piece, metal)
- 1 x AD 854 030 (flat duct bend 90° vertical, metal)
- 1 x AD 410 040 (flat flexible connecting piece)
- 1 x AD 990 091 (adhesive tape for sealing the ducts, aluminium)

Order as set (appliances and accessories):
SET3VL4511 with Stainless steel knob
SET3VL4521 with Black knob

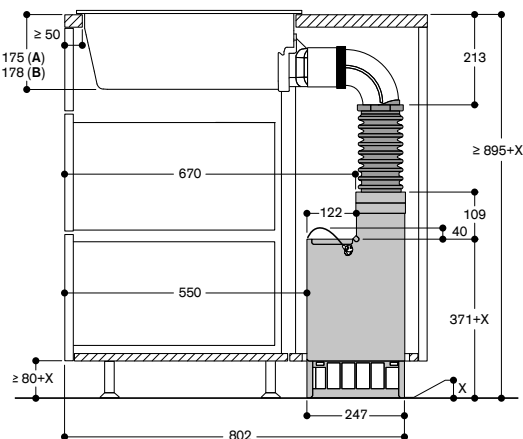
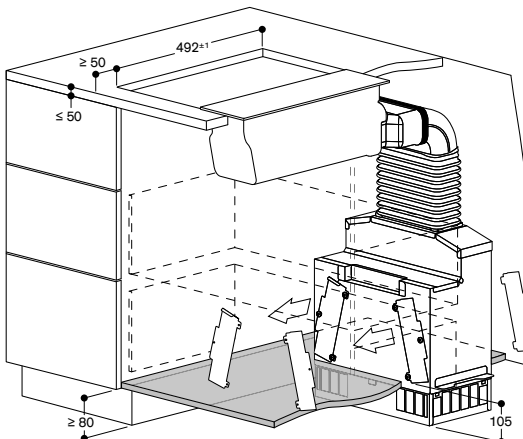

A: Surface mounting
 B: Flush mounting (only VL 414)

Not recommended for non-thermally insulated floor (U ≥ 0.5 W/m²K)

Measurements in mm

List of components - Plastic

- 1 x VL 414 115 Vario downdraft ventilation
- 1 x CKV 410 010 Stainless steel knob or 1 x CKV 410 000 Black knob
- 1 x AR 410 110 (remote fan unit air recirculation)
- 1 x AD 851 041 (connection piece for extension)
- 1 x AD 857 040 (flat duct connecting piece)
- 1 x AD 857 030 (flat duct bend 90° vertical)
- 1 x AD 410 040 (flat flexible connecting piece)

Order as set (appliances and accessories):
SET2VL4711 with Stainless steel knob
SET2VL4721 with Black knob



VL 200 120

Black aluminium control panel
Width 15 cm
Air extraction / Air recirculation
Motorless



In combination with remote fan units

AR 400 142
AR 401 142
AR 403 122
AR 413 122
AR 410 110

Installation accessories

AD 410 040

Flexibel connecting piece for VL 200
DN 150 flat

AD 851 041

Connecting piece VL 200 for extension
with flat duct DN 150 for extra deep
worktop

VV 200 010

Stainless steel connection strip for
combination with other Vario
appliances of the 200 series

VV 200 020

Black connection strip for combination
with other Vario appliances of the
200 series

Special accessories

LS 041 001

Ventilation moulding for VL 200 next to
gas appliance
Stainless steel

Installation accessories for air ducting
you will find at the pages 287 – 293.

Vario downdraft ventilation 200 series

VL 200

- Can be combined with the cooktops of the Vario 200 series to a harmonic unity
- Highly efficient ventilation system at the cooktop integrated in the worktop
- Function for automatic, sensor-controlled power adjustment depending on the build-up of cooking vapours
- Minimal planning and easy installation
- Low-noise system with the motor AR 410 110
- Air extraction or air recirculation system

Output

Power levels depend on the remote fan unit.

Refer to the "Technical specifications" of the hood for the matching remote fan units for air recirculation or air extraction mode.

Features

Control knobs with illuminated ring.
3 electronically controlled power levels and 1 intensive mode.

Automatic sensor-controlled performance adjustment of the ventilation system.

Automatic sensor controlled or manual run on function.

Large-scale metal grease filter with high grease absorption.

Removable, dishwasher-safe grease filter unit.

Grease filter and activated charcoal filter saturation indicator.

Airflow-optimised interior for efficient air circulation.

Interval ventilation, 6 min.

Enamelled ventilation grille, dishwasher-safe.

Air exhaust bend included in delivery.

Overflow 250 ml capacity.

Consumption data

Consumption data is referred to a configuration with the remote fan unit AR 403 122.

Energy efficiency class A at a range of energy efficiency classes from A+++ to D.

Energy consumption 48.3 kWh/year.

Ventilation efficiency class A.

Illumination efficiency class -.

Grease filter efficiency class B.

Sound level min. 56 dB / max. 71 dB normal mode.

Planning notes

The equivalent ducting length to ensure good performance is L_{max} 26 m.

Air recirculation mode in combination with remote fan unit with AR 410 110 or AR 413 122.

Air extraction in combination with remote fan unit AR 400 142, AR 401 142 or AR 403 122.

For each VL one remote fan unit is recommended.

Maximum cooktop width between 2 VL: 80 cm.

Vario cooktops like Vario electric grill and Vario gas wok should be placed between 2 VL.

In case of Vario electric grill recirculation is not recommended.

If installed next to gas appliances, the ventilation moulding LS 041 001 is recommended to ensure maximum performance of the cooktop.

When having installed the ventilation moulding LS 041 001 the wok pan WP 400 001 can not be used.

Air recirculation is not recommended in combination with Vario electric grill. When installing a ventilation hood with air extraction mode and a chimney-vented fireplace, the power supply line of the ventilation appliance needs a suitable safety switch.

Please read additional planning notes on page 262 – 265.

Connection

Connecting cable 1.7 m between VL and remote fan unit.

*Energy efficiency class: at a range of energy efficiency classes from A+++ to D.

Installation of the downdraft ventilation; surface mounting

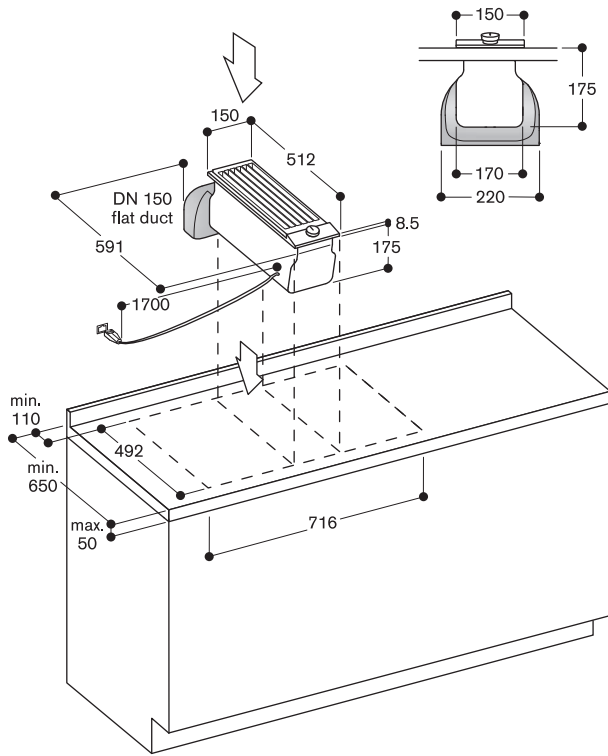

AD 410 040: Flexibel connecting piece for VL, DN 150 flat

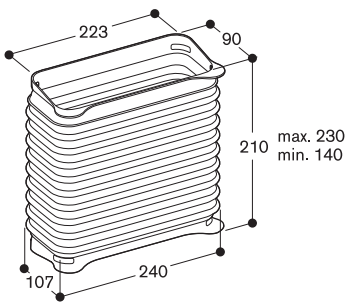

AD 851 041: Connecting piece VL for extension with flat duct DN 150 for extra deep worktop

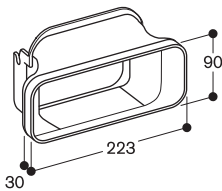

Planning examples with the downdraft ventilation 200 series

Good to know – for correct planning and installation

- For depth measurements, take account of the depth of the furniture cavity and worktop overhangs of the kitchen furniture.
- It is also important that ducting is well sealed in order to prevent air leaks, e.g. by using the adequate adhesive tape or using the adequate connecting piece.
- Maximum distance between the Vario downdraft ventilation and the remote fan unit: Cable length in between 1.7 m
- Vario cooktops like Vario electric grill or Vario gas wok should be placed between 2 VL.
- In case of Vario electric grill air recirculation is not recommended.
- With the Vario downdraft ventilation, the ducting can be connected straight down (1) or to the rear using additional connecting pieces (2) and (3). These are available as special accessories, see below. For the total overall dimensions in the furniture, please also take into account the individual dimensions and position of the ducts and the remote fan unit. The remote fan unit can be turned in all directions, depending on the desired direction for the exhaust air or filter removal.

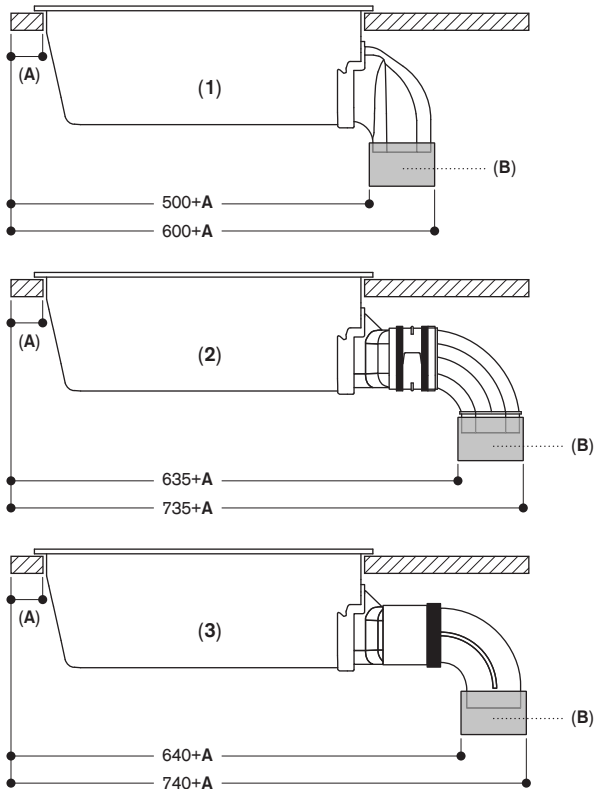

- 1: Direct installation
2: Installation with extension for extra deep worktop and plastic ducting:
- AD 851 041 (Connecting piece for extension)
- AD 857 040 (Flat duct connecting piece, plastic)
- AD 857 030 (Flat duct bend 90° vertical, plastic)
3: Installation with extension for extra deep worktop and metal ducting:
- AD 851 041 (Connecting piece for extension)
- AD 854 000 (Flat duct connecting piece, metal)
- AD 854 030 (Flat duct bend 90° vertical, metal)

A: ≥ 50mm

B: Connecting piece

measurements in mm

Planning example 1 (air recirculation)
VL 200 with AR 410 110 remote fan unit

Wall installation, worktop depth 65 cm, access to the filters for replacement from the front.

Good to know

- Allow accessibility to the charcoal filters in the lower cabinet for their replacement.
- Additionally, if the plinth is higher than 80 mm, the external remote fan unit has to be elevated to enable access to the filters. If the plinth is 80 mm high, the remote fan unit can be placed directly on the floor.
- For optimum performance, the recirculated air requires sufficient space to escape (outflow surface area of at least 400 cm²).

List of components

- 1 x AR 410 110 (remote fan unit air recirculation)
- 1 x AD 410 040 (flexibel connecting piece)

Order as set (appliances and accessories): SET1VL2301

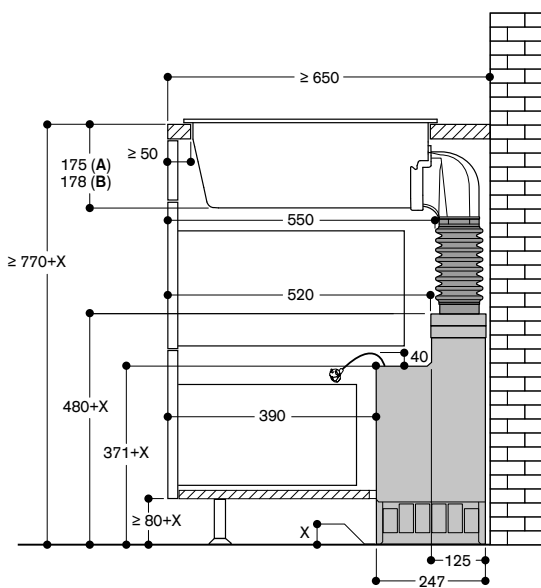
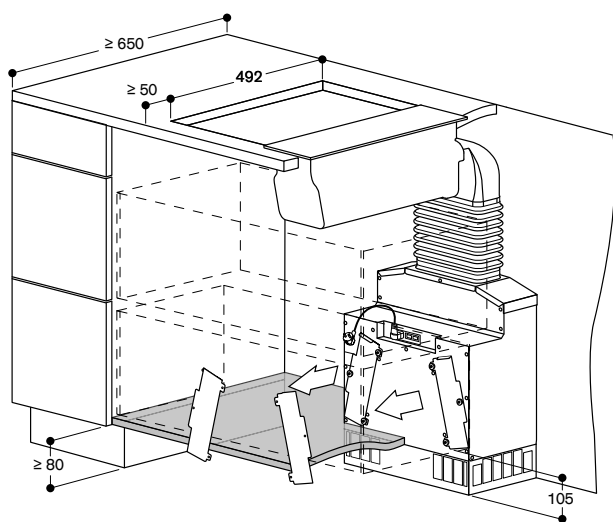

A: Surface mounting
 B: Flush mounting (only VL 414)

Not recommended for non-thermally insulated outer wall or floor ($U \geq 0.5 \text{ W/m}^2\text{K}$)

Measurements in mm

Planning examples with the downdraft ventilation 200 series

Planning example 2 (air recirculation) VL 200 with AR 413 122 remote fan unit

Good to know

- Wall or island installation.
- Allow accessibility to the charcoal filters in the lower cabinet for their replacement.
- The recommended minimum distance between filter openings and cupboard wall if there is no ventilation grille directly in front: 15 cm.
- For optimum performance, the recirculated air requires sufficient space to escape (outflow surface area of at least 400 cm²).

List of components

- 1 x AR 413 122 (remote fan unit air recirculation)
- 1 x AD 410 040 (flat flexible connecting piece)
- 1 x AD 857 015 (flat duct 50 cm)
- 1 x AD 857 040 (flat duct connecting piece)
- 1 x AD 857 041 (flat duct adapter round)
- 1 x AD 990 090 (adhesive tape)

Order as set (appliances and accessories): SET1VL2101

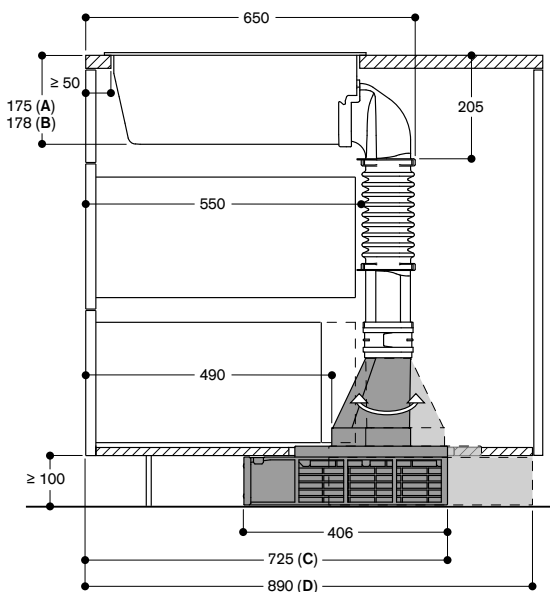
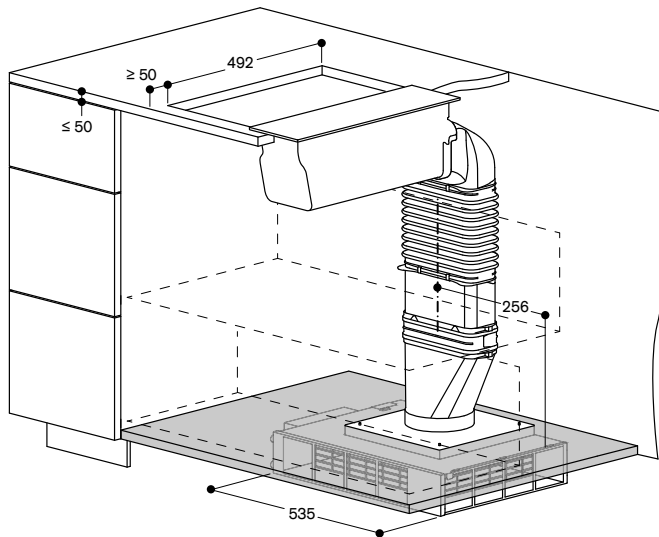

- A: Surface mounting
- B: Flush mounting (only VL 414)
- C: Filter access from the front
Connecting piece flat/round towards the front
- D: Filter access from the back
Connecting piece flat/round towards the back

Not recommended for non-thermally insulated floor ($U \geq 0.5 \text{ W/m}^2\text{K}$)

Measurements in mm

Planning example 3 (air extraction) VL 200 with AR 403 122 remote fan unit

List of accessories

- 1 x AR 403 122 (remote fan unit air extraction)
- 1 x AD 410 040 (flat flexible connecting piece)
- 1 x AD 857 015 (flat duct 50 cm)
- 1 x AD 857 040 (flat duct connecting piece)
- 1 x AD 857 041 (flat duct adapter round)
- 1 x AD 990 090 (adhesive tape)

Order as set (appliances and accessories): SET1VL2703

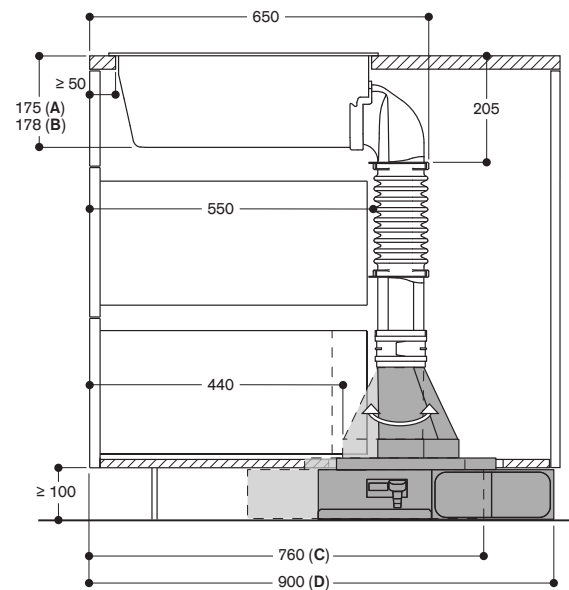
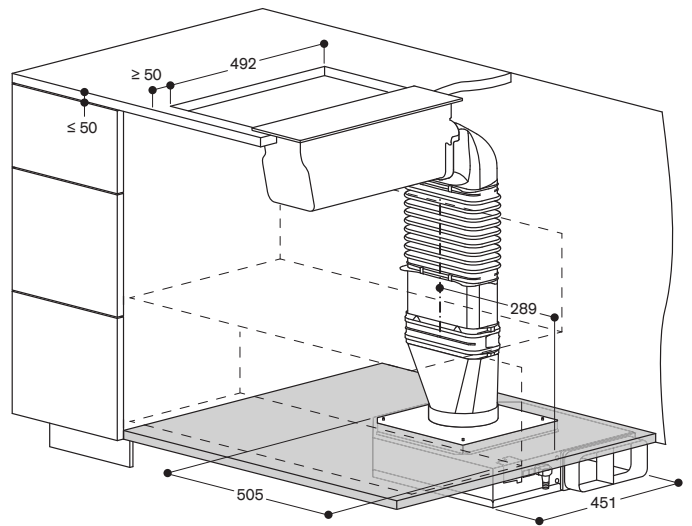

- A: Surface mounting
- B: Flush mounting (only VL414)
- C: Exhaust to the left. Connecting piece flat/round towards the front
- D: Exhaust to the right. Connecting piece flat/round towards the back

measurements in mm

Planning example 4 (air recirculation) - Metal
VL 200 with AR 410 110 remote fan unit

Island installation, access to the filter for replacement from the front or the back.

Good to know

- Allow accessibility to the charcoal filters in the lower cabinet for their replacement.
- Additionally, if the plinth is higher than 80 mm, the external remote fan unit has to be elevated to enable access to the filters. If the plinth is 80 mm high, the remote fan unit can be placed directly on the floor.
- For optimum performance, the recirculated air requires sufficient space to escape (outflow surface area of at least 400 cm²).
- Please note, this installation is also possible with Gaggenau plastic ducts

List of components

- 1 x AR 410 110 (remote fan unit air recirculation)
- 1 x AD 851 041 (connection piece for extension with flat duct for extra deep worktop)
- 1 x AD 854 000 (flat duct bend connecting piece, metal, DN 150 flat)
- 1 x AD 854 030 (flat duct bend 90° vertical, metal, DN 150 flat)
- 1 x AD 410 040 (flexibel connecting piece, DN 150 flat)
- 1 x AD 990 091 (adhesive tape for sealing the ducts, aluminium)

Order as set (appliances and accessories): SET1VL2303

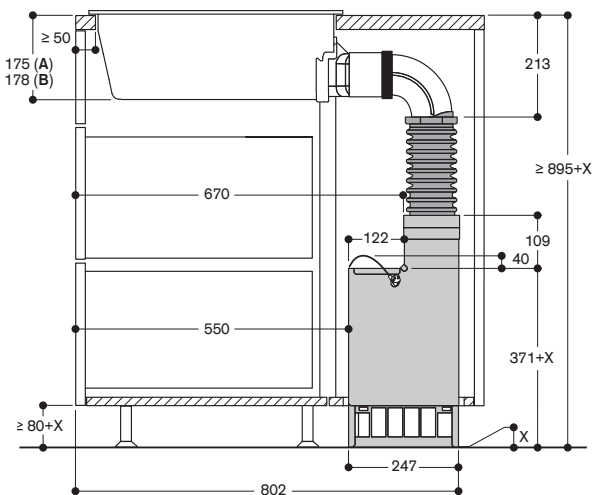
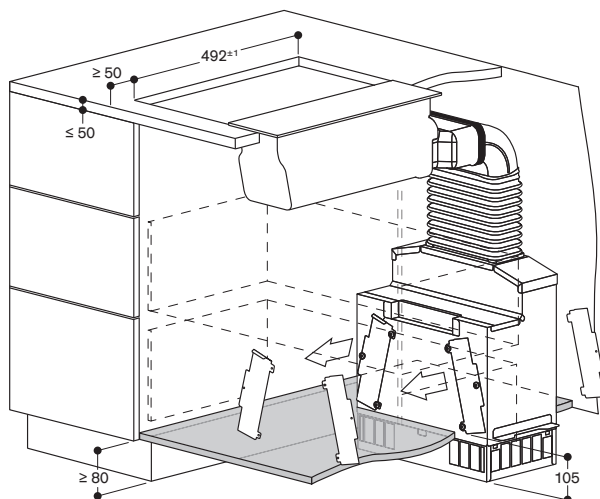

A: Surface mounting
 B: Flush mounting (only VL 414)

Not recommended for non-thermally insulated floor ($U \geq 0.5 \text{ W/m}^2\text{K}$)

Measurements in mm

List of components - Plastic

- 1 x AR 410 110 (remote fan unit air recirculation)
- 1 x AD 851 041 (connection piece for extension)
- 1 x AD 857 040 (flat duct connecting piece)
- 1 x AD 857 030 (flat duct bend 90° vertical, metal)
- 1 x AD 410 040 (flat flexible connecting piece)

Order as set (appliances and accessories): SET2VL2701

Planning example 5 (air extraction) - Metal
VL 200 with AR 403 122 remote fan unit

Island installation, connection from the right side.

List of accessories

- 1 x AR 403 122 (remote fan unit air extraction)
- 1 x AD 858 010 (flat duct flex pipe, metal, DN 150)
- 1 x AD 854 041 (flat duct adapter round, metal, DN 150 flat/round)
- 1 x AD 990 091 (adhesive tape for sealing the ducts, aluminium)

Order as set (appliances and accessories): SET1VL2102

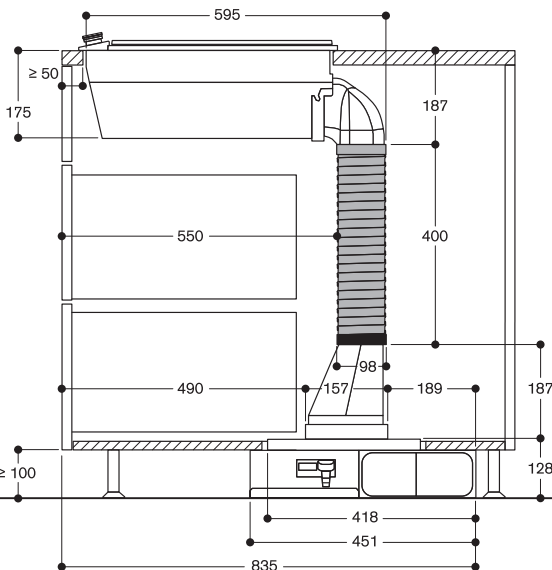
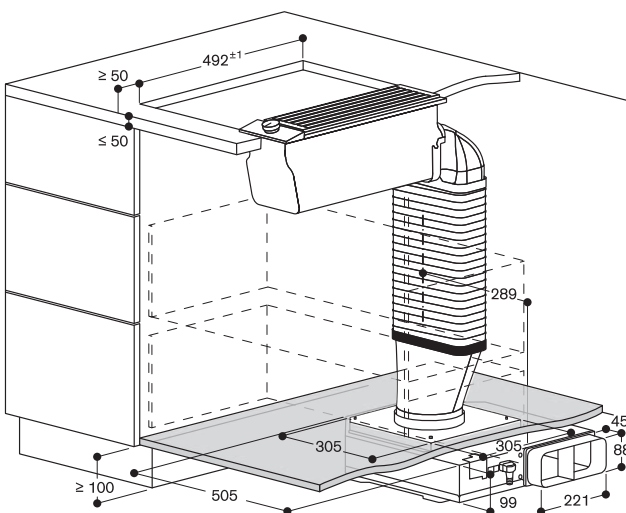



AW 442 120

Stainless steel
Width 120 cm
Air extraction / Air recirculation
Motorless
Chimney needs to be ordered separately



In combination with remote fan units

AR 400 143
AR 400 142
AR 401 142

Necessary installation accessories

AD 442 012
Stainless steel chimney for air extraction
Length: 620 mm

AD 442 022
Stainless steel chimney for air extraction
Length: 860 mm

AD 442 112
Stainless steel chimney for air recirculation
Length: 620 mm

AD 442 122
Stainless steel chimney for air recirculation
Length: 860 mm

AA 442 810
Air recirculation module inclusive 2 activated charcoal filters with highly efficient odour reduction.
For air recirculation.

Special accessories

AA 400 510
Window contact switch

AD 442 392
Ceiling collar for chimneys
Stainless steel

Installation accessories for air ducting you will find at the pages 287 – 293.

Wall-mounted hood 400 series

AW 442

- Professional technology hood combined with classic Gaggenau design
- Highly efficient extraction of cooking vapours due to large vapour collection area
- Motorless, can be combined with Gaggenau BLDC remote fan units
- Angled baffle filter with high grease absorption
- Function for automatic, sensor-controlled power adjustment depending on the build-up of cooking vapours
- Dimmable, neutral white surface LED light for ideal illumination of the cooktop
- Air extraction or air recirculation system
- Air recirculation module with activated charcoal filter: quiet and highly efficient air recirculation solution with odour reduction as in air extraction mode and long replacement intervals

Output

Power levels depend on the remote fan unit.

Refer to the "Technical specifications" of the hood for the matching remote fan units for air recirculation or air extraction mode.

Features

3 electronically controlled power levels and 1 intensive mode.
Automatic function with sensor-controlled run-on function.
Grease filter saturation indicator.
Baffle filter, dishwasher-safe.
Neutral white surface LED light (3500 K), continuously dimmable.
Lamp output 4 x 10 W.
Illuminance 1010 lx.
Easy mounting system for simple installation and alignment.

Consumption data

Consumption data is referred to a configuration AW 442 120 with the remote fan unit AR 400 143.
Energy efficiency class A at a range of energy efficiency classes from A+++ to D.
Energy consumption 48.1 kWh/year.
Ventilation efficiency class A.
Illumination efficiency class B.
Grease filter efficiency class B
Sound level min. 47 dB / max. 64 dB normal mode.

Planning notes

The equivalent ducting length to ensure good performance is Lmax 26 m.
The two-part chimney must be ordered as an installation accessory.
Connection to the respective appliances via network cable.
Two chimney lengths are available depending on the height of the room.
The AR 400 143 remote fan unit is ideal for space-saving installation for assembly in the AW 442.
Clearance above gas appliances min. 70 cm.
Clearance above electric appliances min. 60 cm.
Air recirculation module with 2 activated charcoal filters is installed in the inner chimney. Special air recirculation chimneys are available for this.
When installing a ventilation hood with air extraction mode and a chimney-vented fireplace, the power supply line of the ventilation appliance needs a suitable safety switch.

Special accessories

(order as spare parts):
Part No. 11049036
2 activated charcoal filters with highly efficient odour reduction. For air recirculation module AA 442 810.

Connection

Total connected load 40 W
Connecting cable 1.8 m, pluggable.



AW 240 191

Stainless steel with glass control panel
Gaggenau Anthracite
Width 90 cm
Air extraction / Air recirculation
Delivery with mounting kit and chimney



Necessary installation accessories

AA 200 812

Air recirculation module inclusive
1 activated charcoal filter with highly efficient odour reduction and allergen deactivation.
For air recirculation.

Installation accessories

AD 200 322

Stainless steel chimney extension-
Length: 1000 mm

AD 200 392

Ceiling collar for chimneys
Stainless steel

Special accessories

AA 200 112

1 regenerable activated charcoal filter with highly efficient odour reduction. Extended change interval of the activated charcoal filter: regenerable up to 30 times. Regenerable in the oven at 200 °C. For air recirculation module AA 200 812/816 and AA 010 811/AA 012 811.

Installation accessories for air ducting you will find at the pages 287 – 293.

Wall-mounted hood 200 series

AW 240

- Stainless steel hood with glass cover fitting to oven 200 series
- Highly efficient vapour collection by recessed filters
- Energy-saving, low-noise fan
- Perforated sheet metal filter with high grease absorption
- Function for automatic, sensor-controlled power adjustment depending on the build-up of cooking vapours
- Dimmable, neutral white LED light for ideal illumination of the cooktop
- Air extraction or air recirculation system

Output

Performance and noise level, output level 3/Intensive:

Air output according to EN 61591.

Sound power level according to EN 60704-3.

Air extraction:

618 / 970 m³/h.

64 / 73 dB (A) re 1 pW.

Air recirculation:

383 / 476 m³/h.

69 / 74 dB (A) re 1 pW.

Features

3 electronically controlled power levels and 1 intensive mode.

Automatic function with sensor-controlled run-on function.

Grease filter saturation indicator.

Activated charcoal filter saturation indicator.

Perforated sheet metal filter, dishwasher-safe.

Interval ventilation, 6 min.

Neutral white LED light (3500 K), continuously dimmable.

Light colour in different white tones (2700 – 5000 K) can be adjusted via Home Connect.

Lamp output 3x3 W.

Illuminance 551 lx continuously dimmable.

Fan technology with highly efficient, brushless DC motor (BLDC).

Integrated sound insulation for quiet operation.

Airflow-optimised vapour collection area with slightly inward facing filters.

The package includes an one-way flap.

Easy mounting system for simple installation and alignment.

Selected digital services

(Home Connect)

Cooktop-based ventilation control (with suitable cooktop)

Remote control and monitoring

Remote diagnostics

Please read additional information on Home Connect on page 411.

Consumption data

Energy efficiency class A at a range of energy efficiency classes from A+++ to D.

Energy consumption 44.5 kWh/year.

Ventilation efficiency class A.

Illumination efficiency class A.

Grease filter efficiency class B.

Sound level min. 44 dB / max. 64 dB normal mode.

Planning notes

The equivalent ducting length to ensure good performance is L_{max} 26 m.

The package includes the two-part chimney with the dimensions from

572 mm to 874 mm. Individual planning solutions can be implemented using

the special accessory chimney extension AD 200 322 or by shortening the

lower edge of the inner chimney. Clearance above gas appliances

min. 65 cm (more than total load gas

12 kW min. 70 cm).

Clearance above electric appliances min. 55 cm.

The air recirculation module with

activated charcoal filter can be

installed on the inner chimney.

When installing a ventilation hood with air extraction mode and a chimney-

vented fireplace, the power supply line of the ventilation appliance needs a

suitable safety switch.

Special accessories

(order as spare parts):

Part No. 11033934

2 activated charcoal filters with highly efficient odour reduction and allergen deactivation.

For air recirculation module

AA 200 812/816 and AA 010 811/

AA 012 811.

Connection

Total connected load 269 W.

Connecting cable 1.3 m with plug.

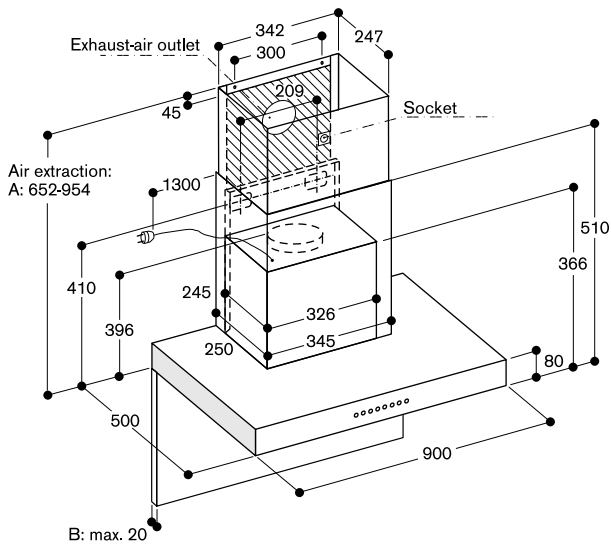

A: Suitable for ceiling heights from 2.25 m to 2.55 m;
 Specifications refer to the distance of 1.60 m from the floor
 to the lower edge of the hood.
 B: Note the maximum thickness of the back panel.

AW 240 with AA 200 812

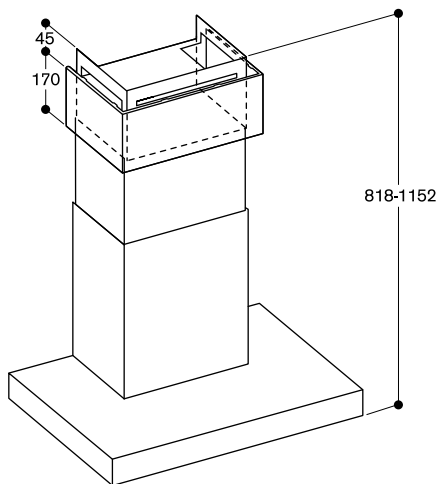

* Suitable for ceiling heights from 2.45 m to 2.75 m;
 Specifications refer to the distance of 1.60 m from the floor
 to the lower edge of the hood.

AW 240 with AD 200 322

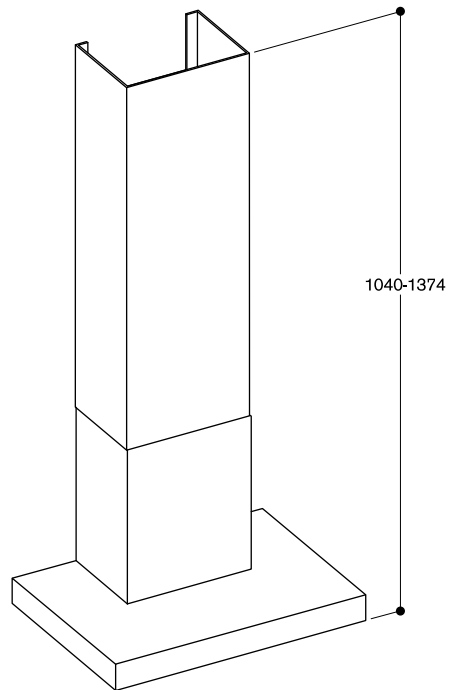

* Suitable for ceiling heights from 2.64 m to 2.97 m;
 Specifications refer to the distance of 1.60 m from the floor
 to the lower edge of the hood.



AI 240 191

Stainless steel with glass control panel
Gaggenau Anthracite
Width 90 cm
Air extraction / Air recirculation
Delivery with mounting kit and chimney



Necessary installation accessories

AA 200 816

Air recirculation module inclusive
1 activated charcoal filter with with
highly efficient odour reduction and
allergen deactivation.
For air recirculation.

Installation accessories

AD 200 326

Stainless steel chimney extension-
Length: 1100 mm

AD 220 396

Ceiling collar for chimneys
Stainless steel

AD 223 346

Extension for mounting kit 500 mm

Special accessories

AA 200 112

1 regenerable activated charcoal filter
with highly efficient odour reduction.
Extended change intervall of the
activated charcoal filter: regenerable
up to 30 times.
Regenerable in the oven at 200 °C.
For air recirculation module
AA 200 812/816 and AA 010 811/
AA 012 811.

Installation accessories for air ducting
you will find at the pages 287 – 293.

Island hood 200 series

AI 240

- Stainless steel hood with glass cover fitting to oven 200 series
- Highly efficient vapour collection by recessed filters
- Energy-saving, low-noise fan
- Perforated sheet metal filter with high grease absorption
- Function for automatic, sensor-controlled power adjustment depending on the build-up of cooking vapours
- Dimmable, neutral white LED light for ideal illumination of the cooktop
- Air extraction or air recirculation system

Output

Performance and noise level, output level 3/Intensive:

Air output according to EN 61591.

Sound power level according to EN 60704-3.

Air extraction:

641 / 988 m³/h.

64 / 72 dB (A) re 1 pW.

Air recirculation:

448 / 530 m³/h.

69 / 72 dB (A) re 1 pW.

Features

3 electronically controlled power levels and 1 intensive mode.

Automatic function with sensor-controlled run-on function.

Grease filter saturation indicator.

Activated charcoal filter saturation indicator.

Perforated sheet metal filter, dishwasher-safe.

Interval ventilation, 6 min.

Neutral white LED light (3500 K), continuously dimmable.

Light colour in different white tones (2700 – 5000 K) can be adjusted via Home Connect.

Lamp output 4x3 W.

Illuminance 650 lx continuously dimmable.

Fan technology with highly efficient, brushless DC motor (BLDC).

Integrated sound insulation for quiet operation.

Airflow-optimised vapour collection area with slightly inward facing filters.

The package includes an one-way flap.

Easy mounting system for simple installation and alignment.

Selected digital services

(Home Connect)

Cooktop-based ventilation control (with suitable cooktop)

Remote control and monitoring

Remote diagnostics

Please read additional information on Home Connect on page 411.

Consumption data

Energy efficiency class A at a range of energy efficiency classes from A+++ to D.

Energy consumption 48.8 kWh/year.

Ventilation efficiency class A.

Illumination efficiency class A.

Grease filter efficiency class B.

Sound level min. 43 dB / max. 64 dB normal mode.

Planning notes

The equivalent ducting length to ensure good performance is Lmax 23 m.

The package includes the mounting kit and the two-part chimney with the dimensions from 664 mm to 844 mm. Individual planning solutions can be implemented using the special accessory chimney extension AD 200 326 in combination with extension for mounting kit AD 223 346.

Clearance above gas appliances min. 65 cm (more than total load gas 12 kW min. 70 cm).

Clearance above electric appliances min. 55 cm.

The air recirculation module with activated charcoal filter can be installed on the inner chimney.

When installing a ventilation hood with air extraction mode and a chimney-vented fireplace, the power supply line of the ventilation appliance needs a suitable safety switch.

Special accessories

(order as spare parts):

Part No. 11033934

2 activated charcoal filters with highly efficient odour reduction and allergen deactivation.

For air recirculation module

AA 200 812/816 and AA 010 811/

AA 012 811.

Connection

Total connected load 272 W.

Connecting cable 1.3 m with plug.

*Energy efficiency class: at a range of energy efficiency classes from A+++ to D.

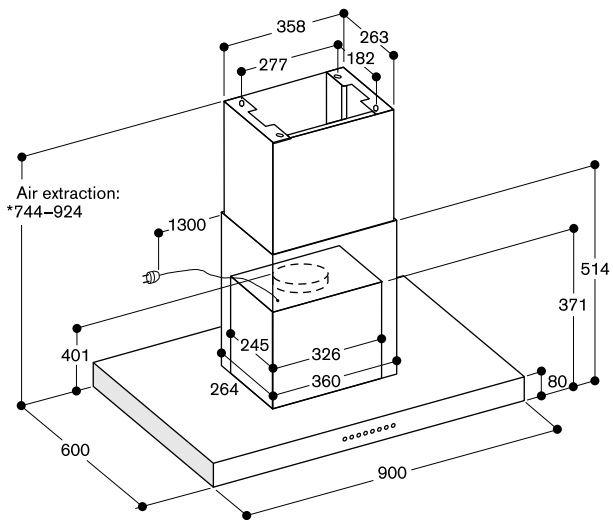

Air extraction:
*744-924

* Suitable for ceiling heights from 2.34 m to 2.52 m;
Specifications refer to the distance of 1.60 m from
the floor to the lower edge of the hood.

AI 240 with AA 200 816

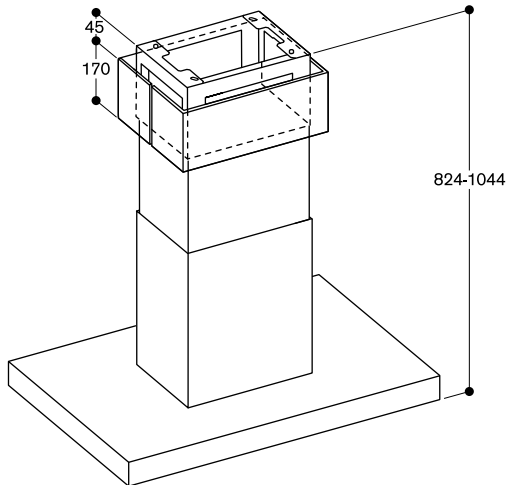

* Suitable for ceiling heights from 2.42 m to 2.64 m;
Specifications refer to the distance of 1.60 m from
the floor to the lower edge of the hood.

AI 240 with AD 200 326 and AD 223 346

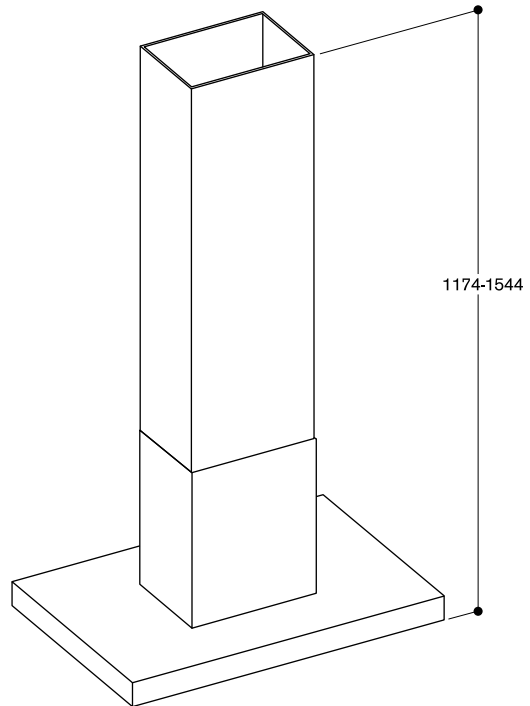

* Suitable for ceiling heights from 2.78 m to 3.15 m;
Specifications refer to the distance of 1.60 m from the
floor to the lower edge of the hood.



AF 210 192

Stainless steel handle bar
Width 90 cm

Air extraction / Air recirculation

AF 210 162

Width 60 cm

Stainless steel handle bar

Air extraction / Air recirculation



Necessary Installation accessories

AA 211 812

Patented air recirculation module including 1 activated charcoal filter with with highly efficient odour reduction and allergen deactivation. For air recirculation.

Installation accessories

AA 210 460

Lowering frame for 60 cm flat kitchen hood

AA 210 492

Lowering frame for 90 cm flat kitchen hood

AA 210 491

Assembly kit for 90 cm upper cabinet
Can be combined with the 90 cm wide flat kitchen hood 200 series in combination with a 90 cm upper cabinet.
For left/right assembly in upper cabinets.
For assembly in the upper cabinet.
If the lowering frame AA 210 492 is used, the assembly kit is not needed.

Installation accessories for air ducting you will find at the pages 287 – 293.

Flat kitchen hood 200 series

AF 210

- Unobtrusive visor hood design thanks to integrated glass sheet in the steam screen
- Especially quiet operation thanks to integrated sound insulation
- Steam screen extends by touching the handle bar
- Especially high air output
- Energy-saving, low-noise fan
- Function for automatic, sensor-controlled power adjustment depending on the build-up of cooking vapours
- Dimmable, neutral white LED light for ideal illumination of the cooktop
- The patented lowering frame allows the visor hood to disappear completely into the upper cabinet
- Air extraction or air recirculation system
- Air recirculation module with activated charcoal filter: quiet and highly efficient air recirculation solution with odour reduction as in air extraction mode and long replacement intervals

Output

Performance and noise level, output level 3/Intensive:

Air output according to EN 61591.

Sound power level according to EN 60704-3.

Appliance width 90 cm

Air extraction:

517 / 965 m³/h

57 / 71 dB(A) re 1 pW

Air recirculation:

506 / 876 m³/h

62 / 69 dB(A) re 1 pW

Appliance width 60 cm

Air extraction:

515 / 953 m³/h

57 / 71 dB(A) re 1 pW

Air recirculation

497 / 885 m³/h

62 / 69 dB(A) re 1 pW

Features

Controls at front.

3 electronically controlled power levels and 1 intensive mode.

Automatic function with sensor-controlled run-on function.

Grease filter saturation indicator.

Stainless steel grease filter, dishwasher-safe.

Neutral white LED light (3500 K), continuously dimmable.

Lamp output 3 x 1.5W / 2 x 1.5W.

Illuminance 355 lx / 294 lx.

Light can be switched on separately.

Fan technology with highly efficient, brushless DC motor (BLDC).

Integrated sound insulation for quiet operation.

The fan is activated when the steam screen is extended.

Patented technology for extension of the steam screen.

Extendable steam screen 198 mm.

Airflow-optimised interior for efficient air circulation and ease of cleaning.

Patented easy mounting system for simple installation.

The package includes an one-way flap.

Consumption data

Consumption data is referred to AF 210 192 / 162.

Energy efficiency class A at a range of energy efficiency classes from A+++ to D.

Energy consumption
41.4 / 40.3 kWh/year.

Ventilation efficiency class A.

Illumination efficiency class A.

Grease filter efficiency class B.

Sound level min. 41/42 dB / max. 57 dB normal mode.

Planning notes

The equivalent ducting length to ensure good performance is L_{max} 23 m.

For air recirculation an external air recirculation module is required.

Patented air recirculation module with activated charcoal filter can be installed in the upper cabinet. The activated carbon filter can be changed from the front by simply pulling out the activated charcoal filter.

The door of the upper cabinet must be fully open in order to change the activated charcoal filter.

To be installed in an upper cabinet without base.

The required cavity depth of the upper cabinet together with the lowering frame measures 335 mm.

The required cavity height of the upper cabinet together with the lowering frame measures 600 mm.

Clearance above gas appliances min. 65 cm (more than total load gas 12 kW min. 70 cm).

Clearance above electric appliances min. 43 cm.

When installing a ventilation hood with air extraction mode and a chimney-vented fireplace, the power supply line of the ventilation appliance needs a suitable safety switch.

Special accessories

(order as spare parts):

Part No. 11034172

1 activated charcoal filter with highly efficient odour reduction and allergen deactivation.

For air recirculation module

AA 211 812.

Connection

Total connected load 266/264 W
Connecting cable 1.8 m, pluggable.

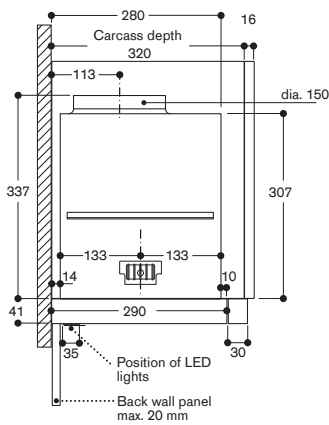
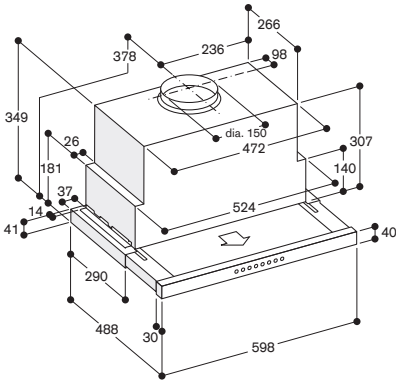
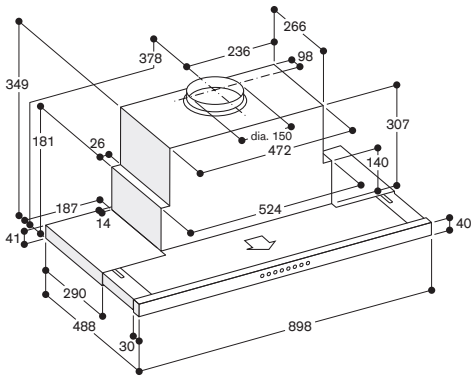

Upper cabinet for AF 210

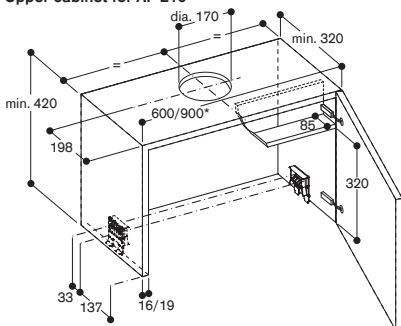

* for upper cabinets measuring 90 cm, the AA 210 491 installation set is required in addition

Upper cabinet for AF210 with assembly kit AA 210 491

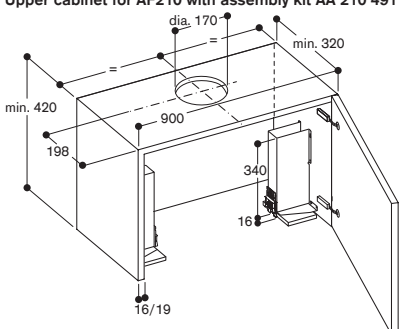

View of upper cabinet from above with AA 211 812

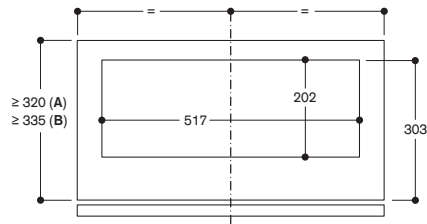

A: Appliance only
B: Appliance with lowering frame
measurements in mm

Cross-section of upper cabinet for AF210 with AA 211 812

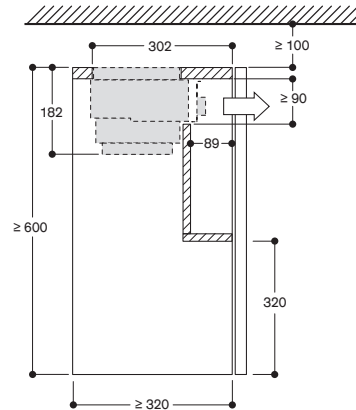

measurements in mm

Cross-section of upper cabinet for AF210 with AA 211 812 and AA 210 492/460 lowering frame

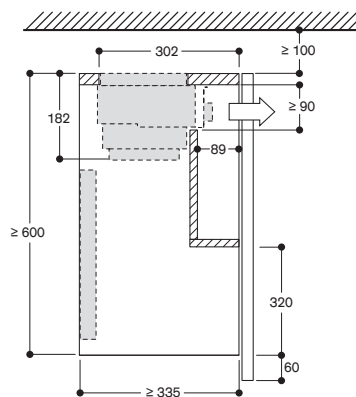

measurements in mm

Upper cabinet for AF 210 with lowering frame

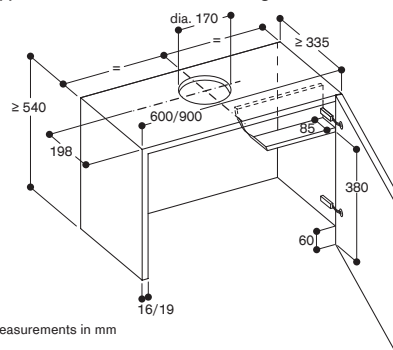

measurements in mm



AC 200 191

Stainless steel and glass

Width 86 cm

Air extraction / Air recirculation

AC 200 181

Stainless steel and glass

Width 70 cm

Air extraction / Air recirculation

AC 200 161

Stainless steel and glass

Width 52 cm

Air extraction / Air recirculation



Necessary Installation accessories

AA 211 812

Patented air recirculation module including 1 activated charcoal filter with highly efficient odour reduction and allergen deactivation.

For air recirculation.

Special accessories

AA 200 510

Remote control for canopy extractor

AC200

Installation accessories for air ducting you will find at the pages 287 – 293.

Canopy extractor 200 series

AC 200

- Can be integrated invisibly in upper cabinet
- Energy-saving, low-noise fan
- Rim extraction with flat and easy-to-clean glass cover
- Dimmable, neutral white LED light for ideal illumination of the cooktop
- Air extraction or air recirculation system
- Energy efficiency class A++

Output

Performance and noise level, output level 3/Intensive:

Air output according to EN 61591.

Sound power level according to EN 60704-3.

Appliance width 86 cm

Air extraction:

610 / 800 m³/h.

64 / 70 dB (A) re 1 pW.

Air recirculation:

540 / 790 m³/h.

72 / 77 dB (A) re 1 pW.

Appliance width 70 cm

Air extraction:

575 / 775 m³/h.

64 / 70 dB (A) re 1 pW.

Air recirculation:

540 / 740 m³/h.

73 / 78 dB (A) re 1 pW.

Appliance width 52 cm

Air extraction:

540 / 730 m³/h.

64 / 70 dB (A) re 1 pW.

Air recirculation:

530 / 690 m³/h.

72 / 77 dB (A) re 1 pW.

Features

3 electronically controlled power levels and 1 intensive mode.

Remote control is available as a special accessory.

Interval ventilation, 6 min.

Run-on function, 6 min.

Grease filter saturation indicator.

Metal grease filter, dishwasher-safe.

Glas filter cover.

Neutral white LED light (4000 K), dimmable.

Lamp output 2 x 1 W.

Illuminance 266 lx.

Fan technology with highly efficient, brushless DC motor (BLDC).

Consumption data

Energy efficiency class A++ at a range of energy efficiency classes from A+++ to D.

Energy consumption

31.4/30.3/29.6 kWh/year.

Ventilation efficiency class A.

Illumination efficiency class A.

Grease filter efficiency class D.

Sound level min. 41/42/44 dB /

max. 64/65/67 dB normal mode.

Planning notes

The equivalent ducting length to ensure good performance is Lmax 19 m.

Patented air recirculation module with activated charcoal filter can be installed in the upper cabinet. The activated carbon filter can be changed from the front by simply pulling out the filter drawer.

The door of the upper cabinet must be fully open in order to change the activated charcoal filter.

Can be integrated invisibly in upper cabinet.

Vario cooktops with intensive production of vapours like VR/VP should be placed in the middle beneath the hood (in this case air recirculation is not recommended).

Clearance above gas appliances min. 65 cm (more than total load gas 12 kW min. 70 cm).

Clearance above electric appliances min. 50 cm.

When installing a ventilation hood with air extraction mode and a chimney-vented fireplace, the power supply line of the ventilation appliance needs a suitable safety switch.

Special accessories

(order as spare parts):

Part No. 11034172

1 activated charcoal filter with highly efficient odour reduction and allergen deactivation.

For air recirculation module

AA 211 812.

Connection

Total connected load 172 W

Connecting cable 1.0 m with plug.

*Energy efficiency class: at a range of energy efficiency classes from A+++ to D.

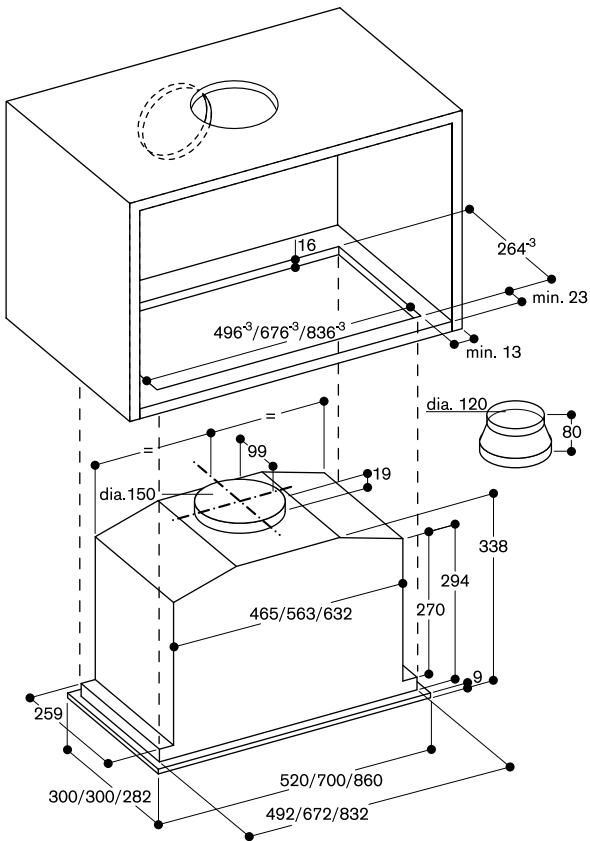

View of upper cabinet from above with AC 200 and AA 211 812

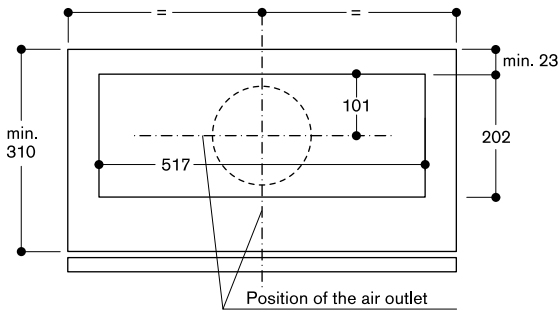

Cross-section of upper cabinet with AC 200 and AA 211 812

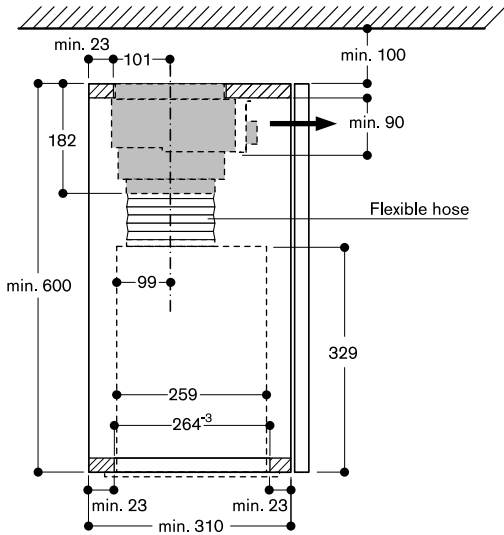



AR 400 142
 Metal housing
 Max. air output 830 m³/h
 Air extraction
 Inside installation

Special accessories
AA 400 510
 Window contact switch

Installation accessories for air ducting
 you will find at the pages 287 – 293.

Remote fan unit

AR 400

- Powerful remote fan unit to combine with motorless appliances
- Efficient BLDC technology

Output

Air output according to EN 61591.
 max. 830 m³/h.
 Sound power depending on built-in situation.
 Power levels depend on the motorless appliances.

Features

3 electronically controlled power levels and one intensive mode.
 Fan technology with highly efficient, brushless DC motor (BLDC).
 Steel housing, zinc-plated.
 Pipe connection pieces on intake side: 1 x DN 150 round, 4 x DN 150 round.
 Pipe connection pieces on output side: 1x DN 150 round.
 Spare cover for closing air intake.
 Retaining bracket for installation on the ceiling or side of a cupboard enclosed.

Planning notes

Remote fan unit in combination with motorless appliances.
 Connection to the respective appliances via network cable.
 Installation in the plinth with cut-out for the air ducting in the furniture base.
 Installation in a separate room allows for a reduced noise level in the kitchen.
 When installing a ventilation hood with air extraction mode and a chimney-vented fireplace, the power supply line of the ventilation appliance needs a suitable safety switch.

Connection

Total connected load 240 W.
 Connecting cable 1.8 m, pluggable.
 Network cable 5 m.

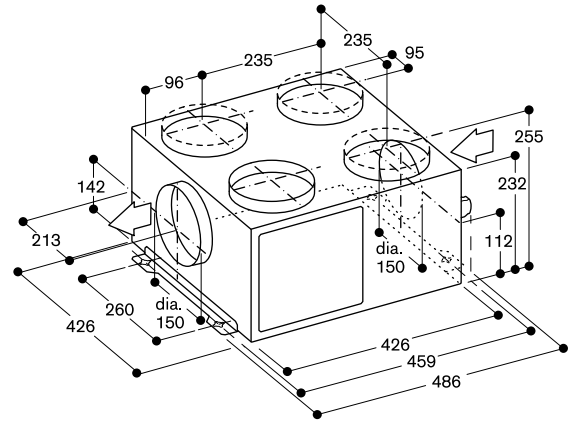

**AR 400 143**

Metal housing
 Max. air output 1005 m³/h
 Air extraction / Air recirculation
 Installation in the chimney of
 AW 442

Special accessories

AA 400 510
 Window contact switch

Installation accessories for air ducting
 you will find at the pages 287 – 293.

Remote fan unit**AR 400**

- Powerful remote fan unit to combine with motorless appliances
- Efficient BLDC technology
- Compact and space-saving due to the installation in the duct cover of AW 442 wall hood

Output

Air output according to EN 61591.
 max. 1005 m³/h.
 Sound power depending on built-in situation.
 Power levels depend on the motorless appliances.

Features

3 electronically controlled power levels and one intensive mode.
 Fan technology with highly efficient, brushless DC motor (BLDC).
 Including sound insulation to minimise the noise level.
 Steel housing, zinc-plated.
 Pipe connection pieces on output side:
 1x DN 150 round.

Planning notes

Remote fan unit in combination with the motorless AW 442.
 Connection to the respective appliances via network cable.
 Installation in the chimney of AW 442.
 When installing a ventilation hood with air extraction mode and a chimney-vented fireplace, the power supply line of the ventilation appliance needs a suitable safety switch.

Connection

Total connected load 230 W.
 Connecting and network cable included in delivery.

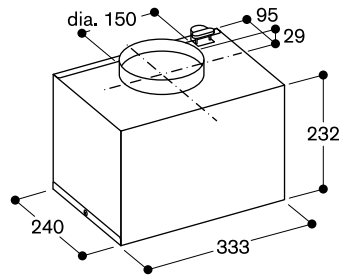



AR 401 142

Stainless steel
 Max. air output 1050 m³/h
 Air extraction
 Outside wall mounting

Installation accessories

AD 702 052
 Telescopic wall-duct
 Connection piece DN 200 round

Special accessories

AA 400 510
 Window contact switch

Installation accessories for air ducting
 you will find at the pages 287 – 293.

Remote fan unit

AR 401

- Powerful remote fan unit to combine with motorless appliances
- Efficient BLDC technology

Output

Air output according to EN 61591.
 max. 1050 m³/h.
 Sound power depending on built-in situation.
 Power levels depend on the motorless appliances.

Features

3 electronically controlled power levels and one intensive mode.
 Fan technology with highly efficient, brushless DC motor (BLDC).
 Including sound insulation to minimise the noise level.
 Stainless steel housing.
 Pipe connection pieces on intake side: 1x DN 200 round.
 Retaining bracket for installation on an outside wall enclosed.

Planning notes

Remote fan unit in combination with motorless appliances.
 Connection to the respective appliances via network cable.
 Installation in an exterior area allows for a reduced noise level in the kitchen.
 Installation on an outside wall.
 Control box must be installed indoors.
 Acceptable temperature range for installation of the control box:
 -25 to 60 °C.
 Distance for free air space from ground (or other object) to center of the pipe: min 60 cm.
 When installing a ventilation hood with air extraction mode and a chimney-vented fireplace, the power supply line of the ventilation appliance needs a suitable safety switch.

Connection

Total connected load 180 W.
 Connecting cable 1.8 m, pluggable.
 Network cable 5 m.

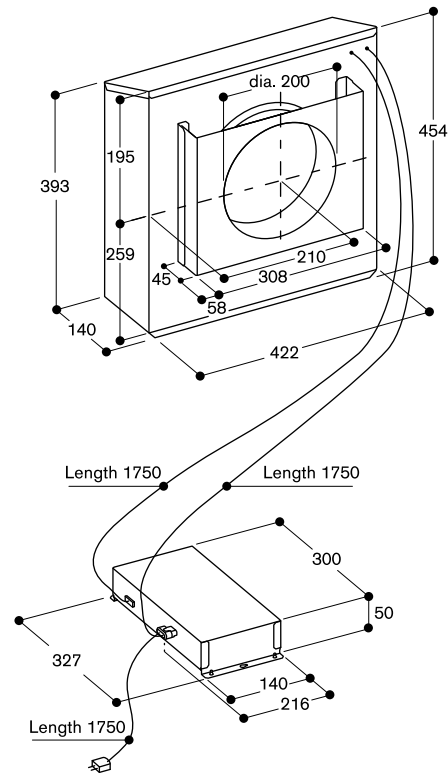

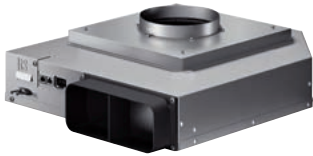
**AR 403 122**

Metal housing
 Max. air output 875 m³/h
 Air extraction
 Plinth installation

Special accessories

AA 400 510
 Window contact switch

Installation accessories for air ducting
 you will find at the pages 287 – 293.

Remote fan unit**AR 403**

- Powerful remote fan unit to combine with motorless appliances
- Efficient BLDC technology
- Compact and space-saving installation in a 10 cm high plinth

Output

Air output according to EN 61591.
 max. 875 m³/h.
 Sound power and sound pressure depending on built-in situation.
 Power levels depend on the motorless appliances.

Features

3 electronically controlled power levels and 1 intensive mode.
 Fan technology with highly efficient, brushless DC motor (BLDC).
 Steel housing, zinc-plated.
 Pipe connection pieces on intake side:
 1 x DN 150 round.
 Pipe connection pieces on output side:
 1x DN 150 flat duct.
 Retaining bracket for installation on the ceiling or side of a cupboard enclosed.

Planning notes

Remote fan unit in combination with motorless appliances.
 Connection to the respective appliances via network cable.
 Installation in the plinth with cut-out for the air ducting in the furniture base.
 When installing a ventilation hood with air extraction mode and a chimney-vented fireplace, the power supply line of the ventilation appliance needs a suitable safety switch.

Connection

Total connected load 180 W.
 Connecting cable 1.8 m, pluggable.
 Network cable 2 m.

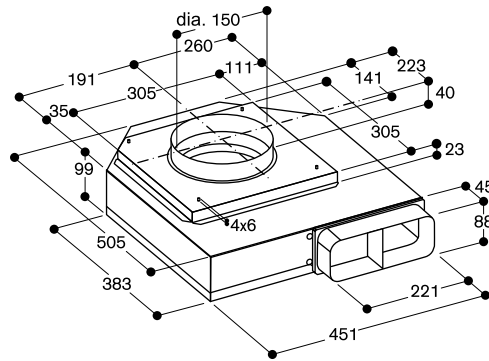

**AR 410 110**

Metal housing
Max. air output 675 m³/h
Air recirculation
Installation in the cupboard

Special accessories**AA 010 410**

Air exhaust grille air recirculation
Stainless steel-coloured, 90 cm,
including installation fittings, height
adjustable.

AA 410 112

2 regenerable activated charcoal filters
with highly efficient odour reduction.
Extended change interval of the
activated charcoal filter: regenerable
up to 30 times.
Regenerable in the oven at 200 °C.
For air recirculation.

Installation accessories for air ducting
you will find at the pages 287 – 293.

Remote fan unit**AR 410**

- Powerful remote fan unit to combine with Vario downdraft ventilation and table ventilation AL 400 122
- Efficient BLDC technology
- Particularly quiet due to patented noise insulation
- Compact, space-saving installation in the cabinet for Vario downdraft ventilation

Output

Air output according to EN 61591.
max. 675 m³/h.
Sound power depending on built-in
situation.
Power levels depend on the motorless
appliances.

Features

3 electronically controlled power levels
and 1 intensive mode.
Fan technology with highly efficient,
brushless DC motor (BLDC).
Including sound insulation to minimise
the noise level.
Steel housing, zinc-plated.
Pipe connection piece on intake side:
1 x DN 150 flat duct.
Retaining bracket for installation at the
furniture base enclosed.
2 activated charcoal filters enclosed ex
factory.
Highly efficient odour reduction for
cooking applications with complex
odour molecules (e.g. fish and seafood).
Filter replacement interval: 1 year
depending on cooking frequency.
2 regenerable activated charcoal filters
in option.

Planning notes

Remote fan unit to combine with Vario
downdraft ventilation and table
ventilation 400 series AL 400 122.
Connection to the respective
appliances via network cable.
Installation in a cupboard possible with
a cut-out in the furniture base or behind
the cupboard positioned on the floor.
To replace the filter the remote fan unit
must be accessible.
The activated charcoal filter exchange
is possible from both sides.
For optimum performance in air
recirculation we recommend an outflow
surface area of at least 400 cm².

Special accessories

(order as spare parts):
Part No. 11028106
2 activated charcoal filters with highly
efficient odour reduction.

Connection

Total connected load 170 W.
Connecting cable 1.8m, pluggable.
Network cable 2 m.

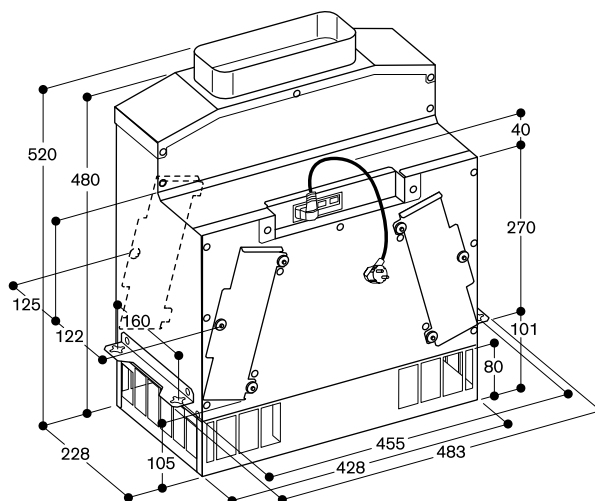
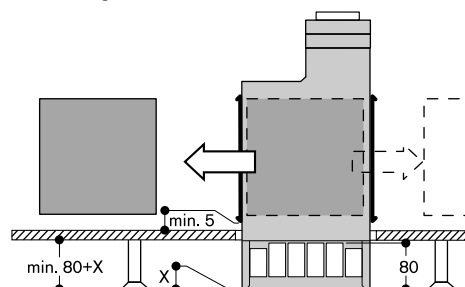
**Filter exchange**

Accessories and special accessories for extractors

AA 442 810

Air recirculation module inclusive 2 activated charcoal filters with highly efficient odour reduction.

For air recirculation.

Can be combined with island and wall-mounted hood AW 442.

Highly efficient odour reduction for cooking applications with complex odour molecules (e.g. fish and seafood).
Extended change interval for the activated charcoal filter (approx. 1–1.5 years depending on cooking frequency).

For installation on the inner chimney.
Consisting of filter bracket, 2 activated charcoal filters, flexible hose and 2 hose clamps.

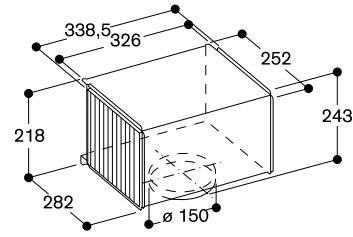

AA 200 812

Combinable with wall mounted hood AW 240.

AA 200 816

Combinable with island hood AI 240.

Air recirculation module inclusive 1 activated charcoal filter with highly efficient odour reduction and allergen deactivation.

Highly efficient odour reduction for cooking applications with complex odour molecules (e.g. fish and seafood).
The filter retains an extremely high amount of airborne pollen and deactivates allergens, which are retained by the filter.

Extended change interval for the activated charcoal filter.

For installation on the external chimney.
Includes design panel, wall fastening (AA 200 812), activated charcoal filter, flexible hose and 2 hose clamps.

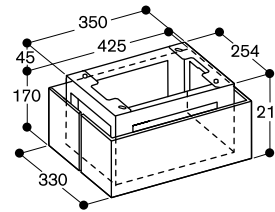
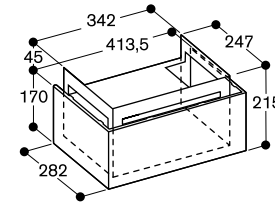

AA 211 812

Patented air recirculation module including 1 activated charcoal filter with highly efficient odour reduction and allergen deactivation.

For air recirculation.

Can be combined with flat kitchen hood series 200/canopy extractor 200 series.

Highly efficient odour reduction for cooking applications with complex odour molecules (e.g. fish and seafood).
The filter retains an extremely high amount of airborne pollen and deactivates allergens, which are retained by the filter.

Extended change interval for the activated charcoal filter.

For assembly in the upper cabinet.

Connecting pipe DN 150 round.

Consisting of filter housing with design panel, activated charcoal panel, activated charcoal filter, flexible hose and 2 hose clamps.

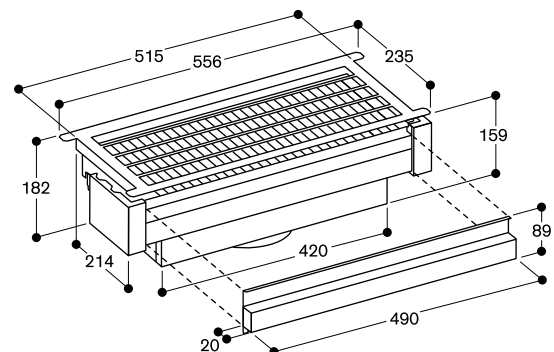

Removable filter panel

AA 010 811
Stainless steel
AA 012 811
White

For air recirculation.
Can be combined with ceiling ventilation AC 250 and AC 402.
Highly efficient odour reduction for cooking applications with complex odour molecules (e.g. fish and seafood).
The filter retains an extremely high amount of airborne pollen and deactivates allergens, which are retained by the filter.
Connecting pipe DN 150 round
Pipe connection at the front, side or top.
Recommended minimum gap between filter openings and wall: 100 cm.

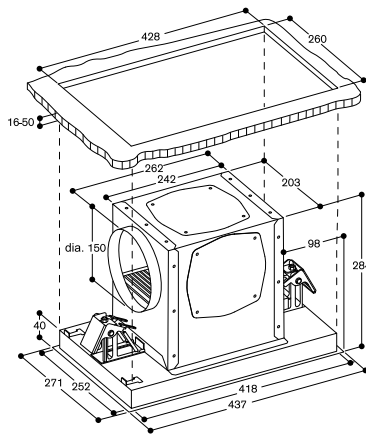

AA 200 880
Combinable with the table ventilation AL 200 180.
AA 200 890
Combinable with the table ventilation AL 200 190.

Recirculation module including activated charcoals filters with highly efficient odour reduction and allergen deactivation.
Easily removal from the top of the table ventilation
Highly efficient odour reduction for cooking applications with complex odour molecules (e.g. fish and seafood).
The filter retains an extremely high amount of airborne pollen and deactivates allergens, which are retained by the filter.



AA 200 882
Combinable with the table ventilation AL 200 180.
AA 200 892
Combinable with the table ventilation AL 200 190.

Regenerable air recirculation module including activated charcoal filters.
Easily removal from the top of the table ventilation for regenerating.
Regenerable in the oven at 200°C.
Extended change interval of the activated charcoal filter: regenerable up to 30 times.



AD 442 392 for AW 442
AD 200 392 for AW 240
AD 220 396 for AI 240
Ceiling collar for air chimneys
Stainless steel/aluminium-lacquered

Covers the fixing screws of wall and island air chimneys as well as uneven gaps at not exactly horizontal ceilings.
Allows the installation of customised one-piece wall chimneys and island chimneys without telescope.



Features
Ceiling fixture for duct and clip-on cover in the color of chimney.

Planning notes
Available for most of the Gaggenau chimney dimensions to fit with standard chimneys.

Ventilation moulding
AA 414 010
Ventilation moulding for VL 414 next to gas appliance.

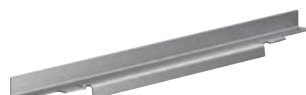

Ventilation moulding
LS 041 001
Ventilation moulding for VL 200 next to gas appliance.

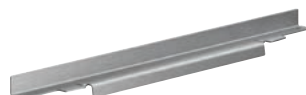

Accessories and special accessories for extractors

Extension for mounting kit for island hood AI 240

AD 223 346

For a chimney height of 1100–1500 mm. Appliance height is dependent on the structure (cabinet height).

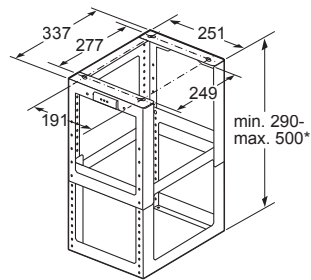
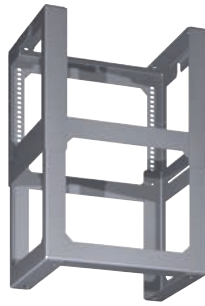

* height-adjustable in 10 mm increments

AA 210 492

Lowering frame for 90 cm flat kitchen hood

AA 210 460

Lowering frame for 60 cm flat kitchen hood

Can be combined with flat kitchen hood series 200.

The patented lowering frame allows the flat kitchen hood to disappear completely into the upper cabinet.

For assembly directly on the kitchen wall or reinforced upper cabinet.

For assembly in the upper cabinet. The required cavity depth of the upper cabinet together with the lowering frame measures 335 mm.

In combination with a back wall panel > 5 mm the lowering frame needs to be adapted accordingly.

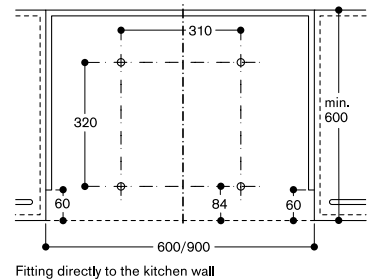
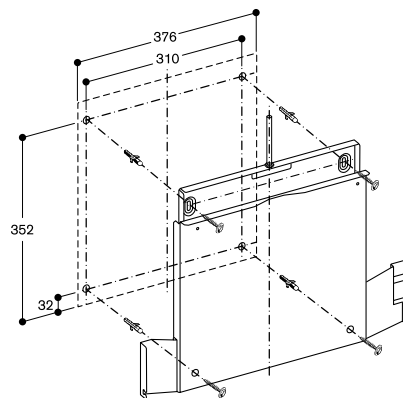
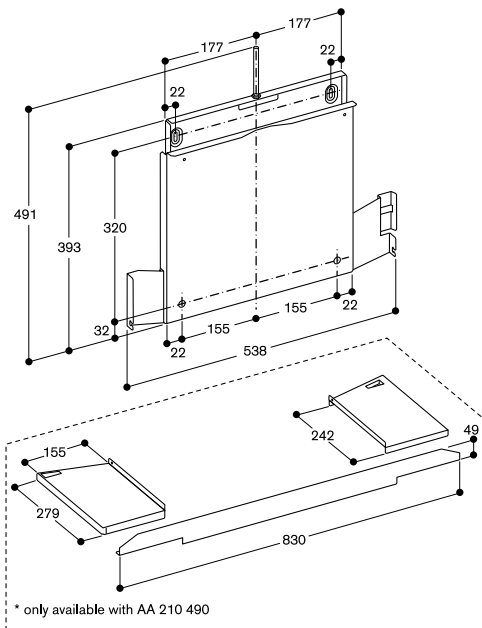
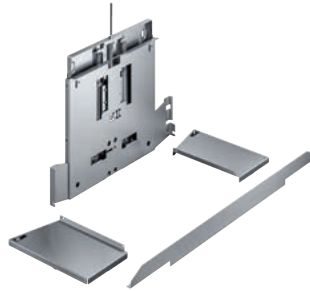

AA 210 491

Assembly kit for 90 cm upper cabinet

Can be combined with the 90 cm wide flat kitchen hoods 200 series.

Flat kitchen hood of 200 series For left/right assembly in upper cabinets.

For assembly in the upper cabinet.

If the lowering frame AA 210 492 is used, the assembly kit is not needed

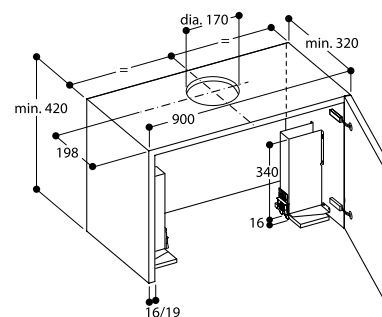

AA 200 900
 Kit for surface mounted installation
 AL 200
 Including 2 trims, each 5 mm width
 For the 80 cm and 90 cm variant
 Gaggenau Black



AL 200 in combination with induction cooktop in 2 separate cut-outs

View from above

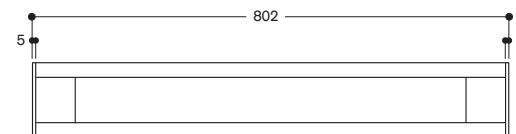

Measurements in mm

AL 200 in combination with induction cooktop in 2 separate cut-outs

View from above

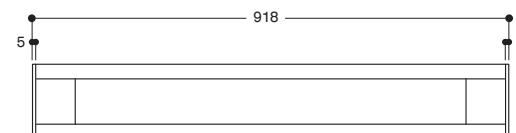

Measurements in mm

AA 200 910
 Installation kit for fan unit at a distance
 (3m maximum)
 Combinable with the table ventilation
 AL 200

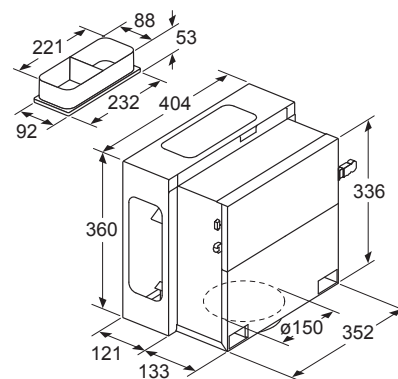
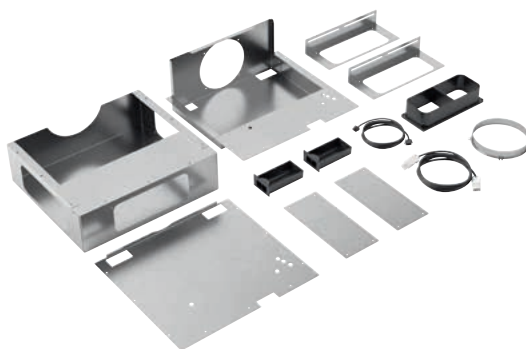

VA 200 080
 Combinable with the table ventilation
 AL 200 180.
VA 200 090
 Combinable with the table ventilation
 AL 200 190.
 Installation kit for installation in a single
 worktop cut-out.
 Consists of a connection strip and
 furniture supports that ensure cabinet
 stability.
 Adjustable for cabinet widths from
 90 cm, 100 cm, 120 cm.

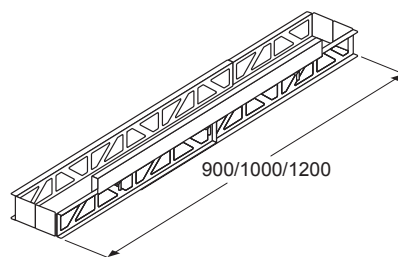
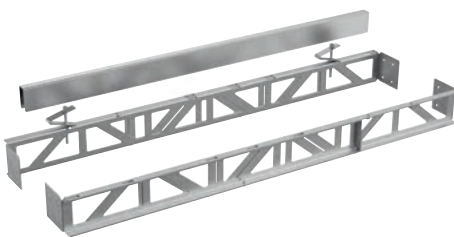

AA 409 401
 Furniture support for table ventilation
 AL 400
 90 cm
 Can be combined with table ventilation
 AL 400.
 Recommended as bearer for the work-
 top, instead of a cabinet frame.

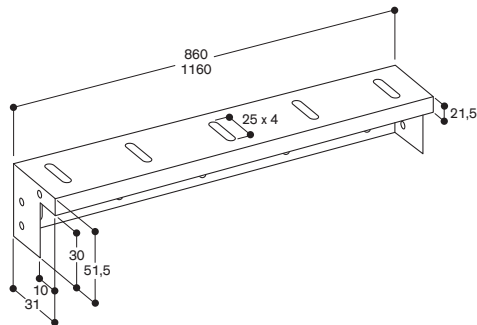
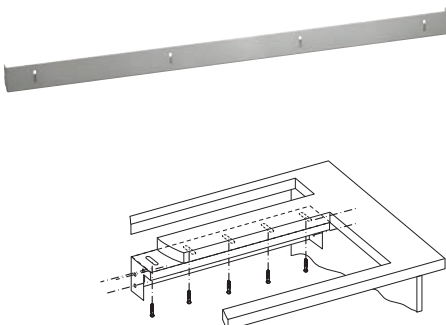

AA 409 431
 Furniture support for table ventilation
 AL 400
 120 cm
 Can be combined with table ventilation
 AL 400.
 Recommended as bearer for the work-
 top, instead of a cabinet frame.

Accessories and special accessories for extractors

AA 400 510

Window contact switch

Can be combined with motorless appliances 400 series.

When installing a ventilation hood with air extraction mode and a chimney-vented fireplace, the power supply line of the ventilation appliance needs a suitable safety switch.

The window contact switch is suitable for this purpose.

The ventilation appliance only works when the window is open if a window contact switch is connected. The lighting works even if the window is closed.

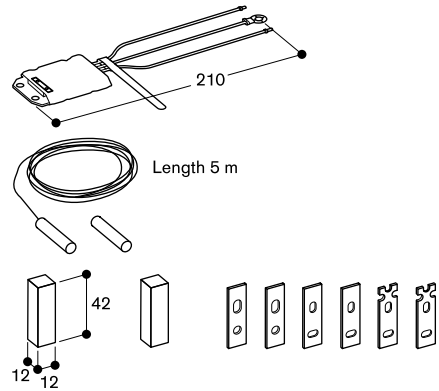

AA 200 510

Remote control for canopy extractor AC 200



AA 010 410

Air exhaust grille air recirculation
Stainless steel-coloured, 90 cm,
including installation fittings, height
adjustable.

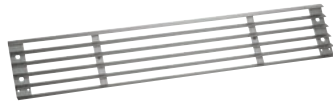

AA 010 410 air exhaust grille

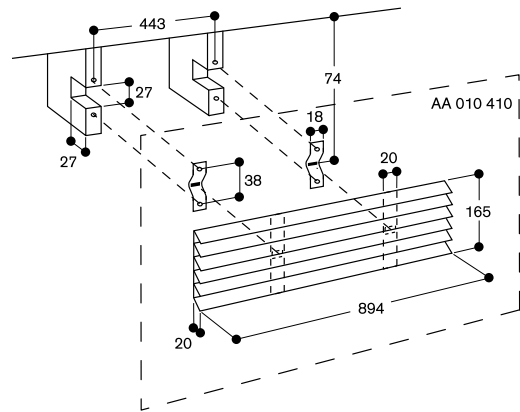

Excellent performance thanks to optimal ducting and installation.

Intelligently selecting and installing the duct system not only has a very positive effect on the output of the ventilation system; it also minimises the noise generated. It is therefore decisive for the efficiency of the entire ventilation system.

The duct type.

In Gaggenau's accessories catalogue, customers can select the type of duct appropriate to their needs, whether aluflex pipe, round duct or a flat duct system. Depending on the duct type, they can choose from the nominal sizes DN 150 and DN 200. For maximum output with minimal noise, the diameter should always be as large as possible.

For straight ducting, the use of plastic or metal ducts with smooth, level inner surfaces is recommended. These enable a laminar flow of air during extraction, without air turbulence. For sections that are not straight and for bends, aluflex pipe are preferred because they make it possible to avoid hard edges.

Where space limitations are a concern, the first choice is the Gaggenau flat duct system. The remarkable design with special conducting fins in the bends and junction pieces allow for a very low height and large nominal size, thus ensuring very efficient air circulation. This also applies in situations where there are many bends. We strongly discourage the use of other flat ducts due to the high output losses in duct bends, duct corners and junction pieces.

Spiral and corrugated ducts should definitely not be used. In addition to displaying the worst flow conditions, these types also tend to flutter and thus generate noise.

The duct diameter.

A good guideline here is: The duct diameter should be as large and constant as possible, while the ducting should be as short and straight as possible. The wall outlet must correspond to the duct diameter.

The building regulations.

Please observe the local applicable building regulation when configuring ventilation solutions.

The plastic flat duct complies with the Needle Flame Test (according to IEC 60695-11-5), the V2 flammability class (according to UL94) and the B1 and B2 building material class (DIN 4102-1) depending on the parts.

The metal ducts are particularly suitable for Vario downdraft and Table ventilation in countries with increased fire protection requirements.

The metal ducts are non-combustible and suitable for all combinations.

AD 857 015

Flat duct
Plastic, low flammability
DN 150 flat
Length 500 mm



AD 857 010

Flat duct
Plastic, low flammability
DN 150 flat
Length 1000 mm

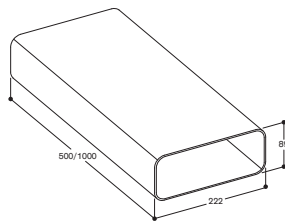

AD 854 010

Flat duct
Metal
DN 150 flat
Length 1000 mm

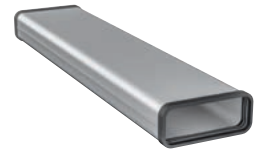

Features

Sealing is pre-assembled on each side.

Planning notes

Suitable for flat duct bends.
To connect 2 flat ducts, a flat duct connecting piece is required.
If the removal of the seal is necessary, the connection must be fastened and sealed with aluminium adhesive tape.

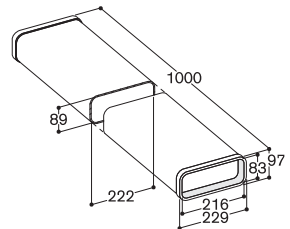

AD 857 040

Flat duct connecting piece
Plastic, low flammability
DN 150 flat
Connector sleeve to connect other plastic flat ducts together.



Features

Integrated sealings for full airtightness without necessity for any adhesiv tape. Easy-to-connect via time saving click mechanism.

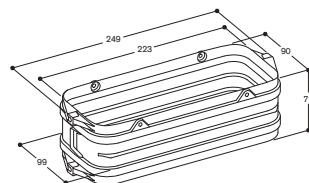

AD 854 040

Flat duct connecting piece
Metal
DN 150 flat
To connect 2 flat ducts.



Planning notes

Suitable for flat duct and flat duct flex.

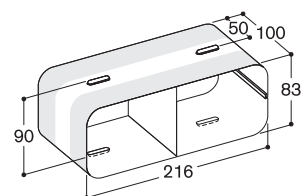

Installation accessories for air ducting

AD 857 030
 Flat duct bend 90° vertical
 Plastic, low flammability
 DN 150 flat

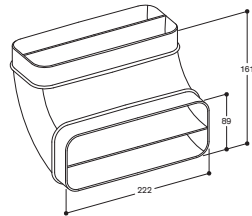

AD 854 030
 Flat duct bend 90° vertical
 Metal
 DN 150 flat

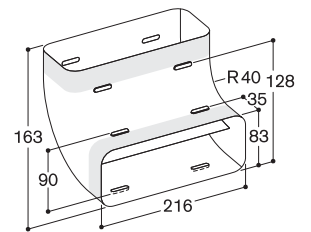

Planning notes
 Suitable for flat duct and flat duct flex.

AD 857 031
 Flat duct bend 90° horizontal
 Plastic, low flammability
 DN 150 flat

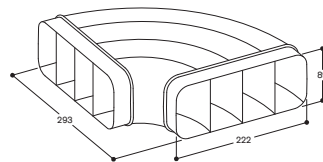

AD 854 031
 Flat duct bend 90° horizontal
 Metal
 DN 150 flat

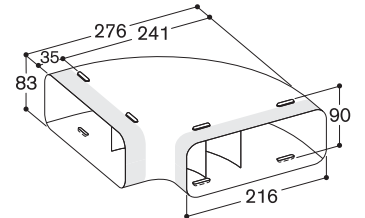
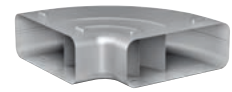

Planning notes
 Suitable for flat duct and flat duct flex.

AD 854 000
 Flat duct bend connecting piece
 Metal
 DN 150 flat
 To connect 2 flat duct bends.

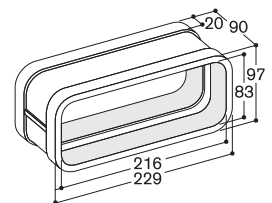

Planning notes
 If the removal of the seal is necessary, the connection must be fastened and sealed with aluminium adhesive tape.

AD 853 011
 Flat duct system flex pipe
 Plastic low flammability
 DN 150 flat
 Length: 1000 mm

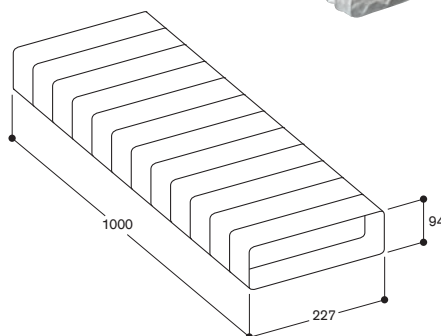

AD 858 010
 Flat duct flex pipe
 Metal
 DN 150 flat
 Length 1000 mm

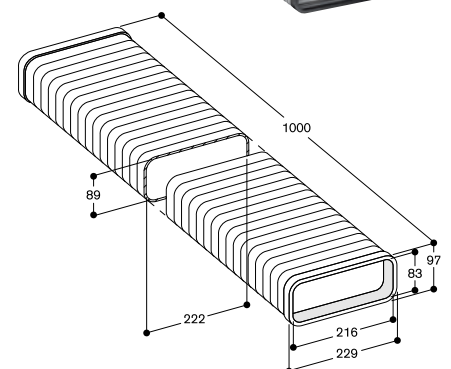
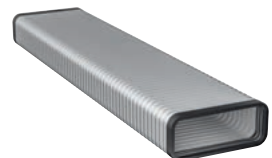

Planning notes
 Suitable for flat duct bends.
 Flat duct flex pipe can be shortened.
 Useful for bends (<90°) or for parallel offsetting.
 If the removal of the seal is necessary, the connection must be fastened and sealed with aluminium adhesive tape.

AD 857 042

Flat duct adapter round 90°
 Plastic, low flammability
 DN 150 flat / round
 Transition from flat duct to round duct.

Planning notes

Suitable for flat duct and flat duct flex.
 Suitable for round duct (with pipe connector), and aluflex pipe.

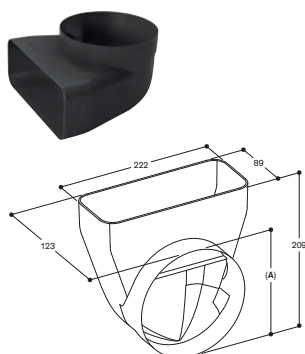

A: ø 152.5
 measurements in mm

AD 854 032

Flat duct adapter round 90°
 Metal
 DN 150 flat/round
 Transition from flat duct to round duct.

Planning notes

Suitable for flat duct and flat duct flex.
 Suitable for round duct and aluflex pipe.

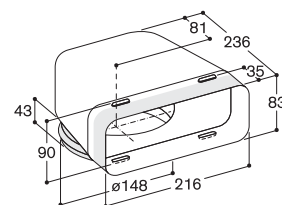

AD 857 041

Flat duct adapter round
 Plastic, low flammability
 DN 150 flat / round
 Transition from flat duct to round duct.

Planning notes

Suitable for flat duct and flat duct flex.
 Suitable for round duct (with pipe connector), and aluflex pipe.

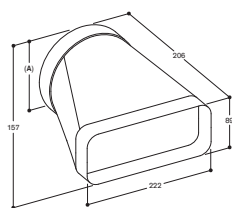

A: ø 152.5

AD 854 041

Flat duct adapter round
 Metal
 DN 150 flat/round
 Transition from flat duct to round duct.

Planning notes

Suitable for flat duct and flat duct flex.
 Suitable for round duct and aluflex pipe.

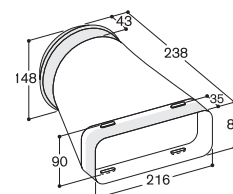

AD 990 091

Adhesive tape for duct components
 Aluminium
 Width 50 mm
 10 m/roll

Planning notes

Useful for all connections of duct components.

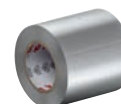

Installation accessories for air ducting

AD 410 040

Flexibel connecting piece for VL 200 and VL 414
DN 150 flat

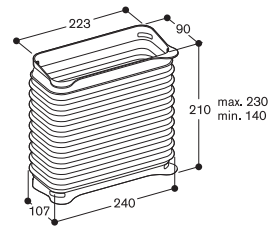

AD 851 041

Connecting piece VL 200 and VL 414
for extension with flat duct DN 150 for
extra deep worktop

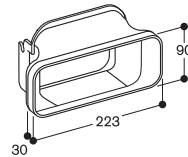
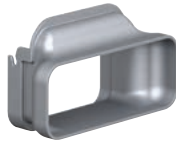

AD 754 049

Connecting piece for AL 400
Metal zinc coated
DN 150 round

Planning notes

Fitting AL 400, front or back side.
2 x DN 150 round duct air intake.

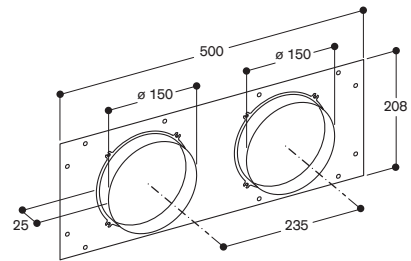

AD 854 050

Connecting piece for AL 400
Metal zinc coated
DN 150 flat

Planning notes

Fitting AL 400, bottom side.
2 x DN 150 flat duct air intake.

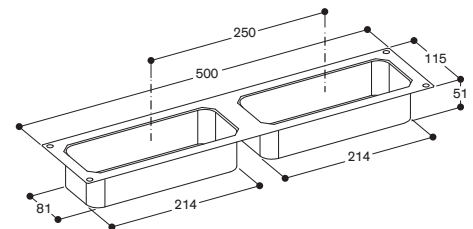
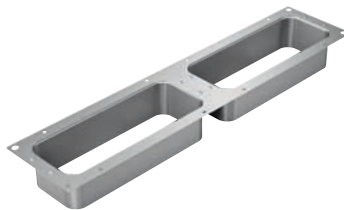

AD 704 050

Air collector box for AL 400
Metal zinc coated
DN 150 flat

Planning notes

1 x Air collector box.
2 x DN 150 flat duct air intake.
To connect AL 400 to the remote fan
unit AR 403 / AR 413 bottom side.
1 x DN 200 round duct air outlet.
To connect AL 400 to the remote fan
unit AR 401 (in combination with the
air collector).
1 x DN 200 round duct air intake.
To connect AL 400 to the remote fan
unit AR 403 in the cellar (in combina-
tion with the air collector and the DN
200 air outlet).

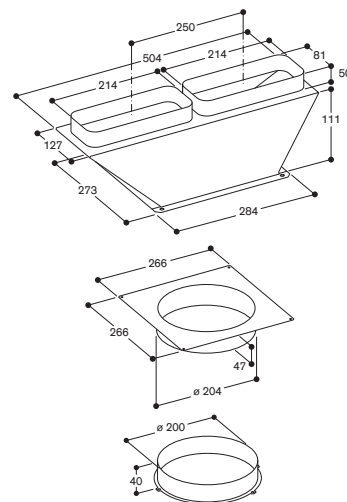

AD 854 048

Air collector box DN 150 flat duct

Planning notes

For connecting two filter modules AC 402, integrate a controle module with or without light in between:
 2 x DN 150 flat duct air intake.
 1 x DN 150 flat duct air outlet.

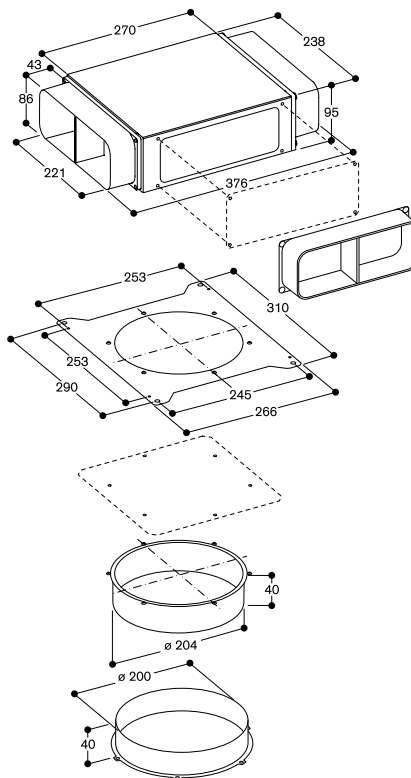

AD 754 048

Air collector box DN 150 round pipe

Planning notes

For connecting two filter modules AC 402, integrate a controle module with or without light in between:
 2 x DN 150 round duct air intake.
 1 x DN 150 round duct air outlet.

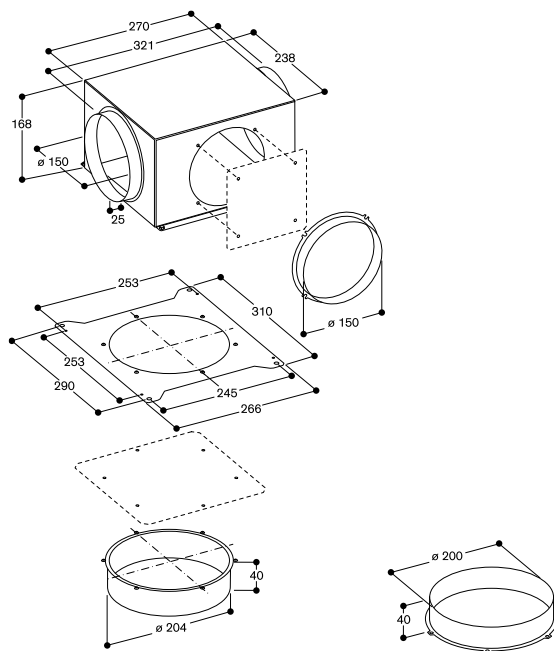
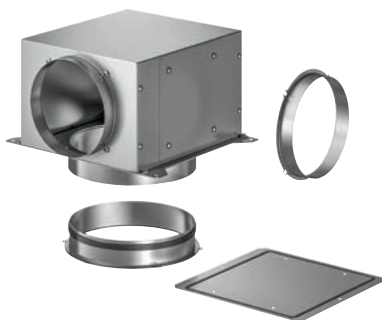

AD 751 010

Aluflex pipe
 Aluminium
 DN 150 round

Planning notes

Recommended only for routing ducting through air paths which are not in a straight line or for round wall and floor apertures. 2 hose clamps enclosed. For combination with all adapters, press the pipe wall flat at the ends. 2 aluflex pipes must be connected with a pipe connection piece for aluflex pipes.

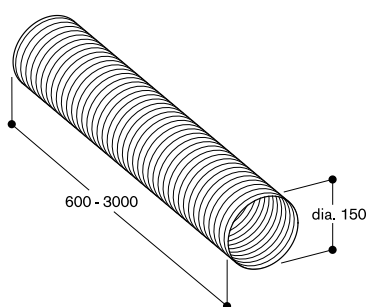

Installation accessories for air ducting

AD 752 010

Round duct
Plastic, low flammability
DN 150 round

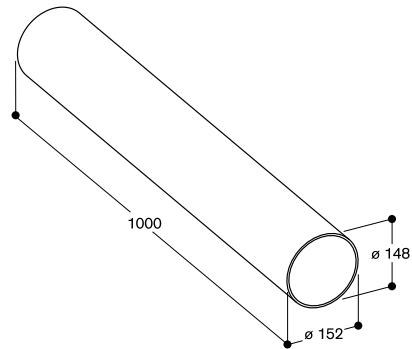

Planning notes

2 round ducts must be connected with the pipe connector AD 754 090.

AD 754 090

Pipe connector for plastic pipe
Plastic
DN 150 round

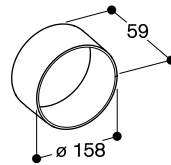

Planning notes

2 round ducts must be connected with the pipe connector AD 754 090.

AD 704 040

Pipe adapter DN 200/150 round
Metal zinc plated
DN 200 round
Reduce DN 200 connection to DN 150 connection.

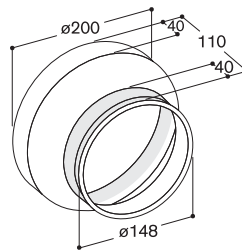

Planning notes

Can be combined with telescopic wall-duct DN 200 and pipe connector DN 150.

AD 752 030

Duct bend 90°
Plastic
DN 150 round

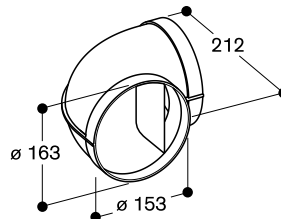

AD 752 070

Condensation trap
Plastic
DN 150 round

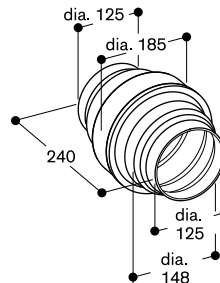

Planning notes

Recommended under vertical pipe sections. Installation on the bottom end of the pipe.

AD 990 090

Adhesive tape for duct components
Plastic
10 m/roll



RK 040 150

One-way flap for insertion in the exhaust air outlet of the hood.
DN 150 round.



Planning notes

In order that ducting is well sealed and air leaks are consequently prevented, the adhesive tape AD 990 090 is necessary at all pipe connection piece points. The adhesive tape is heat- and UV-resistant.

AD 700 051

Wall outlet

Stainless steel
DN 200 round

Little loss of airflow due to large stainless steel outlet louvers.

Features

Weatherproof stainless steel louvers.
Integrated one-way flap.
Connecting piece DN 200 round

Planning notes

For use with telescopic wall-duct
AD 702
Wall breakthrough \varnothing 210 mm

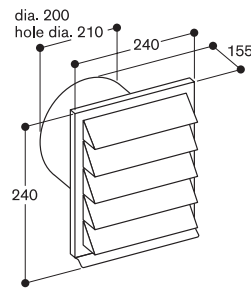

AD 850 050

Wall outlet

Stainless steel
DN 150 flat

Little loss of airflow due to large stainless steel outlet louvers.
Compact dimensions by flat structure.
Connecting piece flat duct DN 150.

Features

Weatherproof stainless steel louvers.
Integrated one-way flap.

Planning notes

Direct connection of flat duct DN 150
without pipe connector.

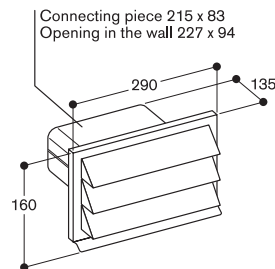

AD 702 052

Telescopic wall-duct

Stainless steel
DN 200 round

Features

Connecting piece DN 200 round.
Integrated one-way flap.

Planning notes

For use with wall outlet AD 700 051 or
remote fan unit AR 401.

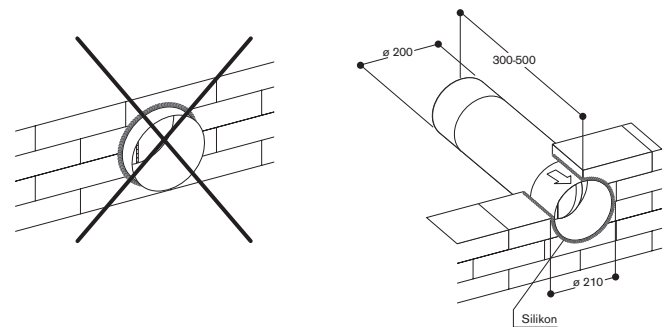

AD 750 054

Wall outlet with telescopic duct

Stainless steel/plastic
DN 150 round

Optimal temperature insulation.
Hermetically sealed by an optimized built-in heat retention system. Flat stainless steel cover with minimal effect to the aesthetics of the building exterior facade.

Features

Weatherproof stainless steel louvers.
3-times insulating Backflow system.
Magnetic opening and closing.
Defined opening pressure (65 Pa) prevents rattling.
Full opening even at low flow rates.
Telescopic wall duct 350 - 500 mm for round pipe connection piece DN 150.

Planning notes

Conform to blower-door test.
For connection of round pipe DN 150 or flat pipe DN 150. Wall breakthrough \varnothing 155 mm.

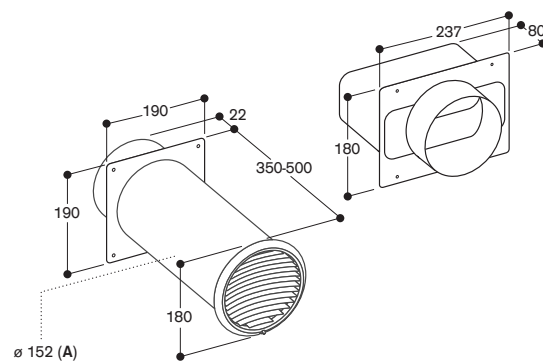
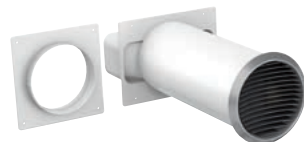

A: Drilling \varnothing 155
measurements in mm

Ceiling ventilation 400 series



Appliance type	Ceiling ventilation	Ceiling ventilation	Ceiling ventilation
Stainless steel	Filter module	Control module	Light module
Air extraction / air recirculation	AC 402 181	AC 482 181	AC 472 181
Air extraction / air recirculation	• / •		
Compatible with (air extraction):	AR 400 142 / AR 401 142 / AR 403 122		
Compatible with (air recirculation):	AR 400 142 and AA 010 811 or AA 012 811		
Dimensions			
Width of overall frame	(cm) 80	80	80
Depth of overall frame	(cm) 40	14	14
Height	(cm) 10.5	13.5	13.5
Net weight	(kg) 8	9.5	9.5
Consumption data according to EU regulation 65 / 2014			
Energy efficiency class	B ^{*3}		
Energy consumption	kWh/year	60.6 ³	
Ventilation efficiency class		A ^{*3}	
Illumination efficiency class		E ^{*3}	
Grease filter efficiency class		B ^{*3}	
Sound level min. / max. normal mode	dB(A)	50/65 ³	
Air extraction performance (EN 61591) with fan units, power level 1 / 2 / 3 / Intensive		Airflow per remote fan unit with one filter module ²	
Air extraction with AR 400 142 for inside installation	(m ³ /h) at 5 Pa	300/460/570/720	–
Air extraction with AR 401 142 for outside installation	(m ³ /h) at 5 Pa	340/510/640/750	–
Air extraction with AR 403 122 for inside installation	(m ³ /h) at 5 Pa	370/490/640/780	
Air recirculation with AR 400 142 and AA 010 811 or AA 012 811	(m ³ /h) at 0 Pa	260/400/500/570	
Features			
Infrared remote control		•	
Power levels		3 plus intensive	
Run-on function		•/6 min.	
Interval ventilation		•/6 min.	
Grease filter saturation indicator		–/•	
Grease filter art	Rim extraction		
Grease filter units	2		
Art of lighting		LED	LED
Exhaust air connection bottom / side / top / back	–/–/•/–		
Exhaust air connection piece DN 150 round duct	•		
Exhaust air connection piece DN 150 flat duct	AD 852 042 ¹		
Connecting cable length	(m)	1.75	1.75
Network cable length			2
Cooktop-based ventilation control		–	
Home network integration for digital services (Home Connect) wireless via WiFi.		–	
Minimum clearance above cooking position			
For gas appliances with total connected load gas of less / more than 12 kW	(cm) 70/70	70/70	70/70
For electric appliances	(cm) 70	70	70
Connection			
Total connected load	(W)	depending on fan unit	
Radio frequency interference-suppressed		•	•

• Standard. – Not available.

¹ Special accessory.

² For configurations with more than one filter module per fan unit up to 70 m³/h can be added.

³ Values refers to the configuration AC 402 181 (1x), AC 482 181 (1x), with the remote fan unit AR 400 142.

* Energy efficiency class: at a range of energy efficiency classes from A+++ to D.

Ventilation, Illumination, Grease filter efficiency : at a range of classes from A to G.



Appliance type		Ceiling ventilation
Gaggenau Light Bronze		AC 250 121
Air extraction / air recirculation		• / Air recirculation module as accessory
Dimensions		
Width of overall frame	(cm)	120
Depth of overall frame	(cm)	50
Height	(cm)	30
Net weight	(kg)	37
Consumption data according to EU regulation 65 / 2014		
Energy efficiency class		A⁺ *
Energy consumption	kWh/year	35.2
Ventilation efficiency class		A*
Illumination efficiency class		-
Grease filter efficiency class		E*
Sound level min. / max. normal mode	dB(A)	41/56
Air extraction performance (EN 61591) with fan units, power level 1 / 2 / 3 / Intensive		
Air extraction	(m ³ /h) at 5 Pa	265/331/458/933
Air recirculation	(m ³ /h) at 0 Pa	197/313/419/637
Max. back pressure at 0 m ³ /h	(Pa)	416
Sound power level (EN 60704-3) max/Int		
Air extraction mode	(dB(A) re 1 pW)	56/70
Air recirculation mode	(dB(A) re 1 pW)	63/72
Air extraction ducting recommendation		
Equivalent ducting length Lmax	(m)	23
Features		
Remote control		•
Power levels		3 plus intensive
Run-on function		• / integrated
Interval ventilation		• / 6 min.
Grease filter saturation indicator		•
Activated charcoal filter saturation indicator		•
Grease filter art		Cartridge-type filter
Grease filter units		2
Art of lighting		-
Lamp output	(W)	-
Illuminance	(lx)	-
Lighting colour	(Kelvin)	-
Colour range (adjustable with Home Connect)	(Kelvin)	-
Exhaust air connection piece	(ø mm)	150
Exhaust air connection piece, top / side / rear / front		- / • / • / •
Connecting cable length	(m)	1.3
Cooktop-based ventilation control		• ¹
Home network integration for digital services (Home Connect) wireless via WiFi. ²		•
Accessories		
Air recirculation module White		AA 010 811
Air recirculation module Stainless steel		AA 012 811
Regenerable activated charcoal filter		AA 200 112
Activated charcoal filter (order as spare parts)		Part No. 11033934
Minimum clearance above cooking position		
For gas appliances with total connected load gas of less / more than 12 kW	(cm)	65/70
For electric appliances	(cm)	65
Connection		
Total connected load	(W)	250
Radio frequency interference-suppressed		•

• Standard. – Not available.

¹ Via Home Connect; in combination with suitable cooktop.

² The use of the Home Connect functionality depends on the Home Connect services, which are not available in every country.

* Energy efficiency class: at a range of energy efficiency classes from A+++ to D.

Ventilation, Illumination, Grease filter efficiency: at a range of classes from A to G.

Table ventilations 400 series



Appliance type	Table ventilation	
Stainless steel	AL 400 122	AL 400 192
Air extraction / air recirculation	• / •	• / •
Compatible with (air extraction): For EU countries, the AL 400 122 is only recommended in air recirculation due to legislation EU 66/2014.	2x AR 400 142 / 2x AR 401 142 / 2x AR 403 122	AR 400 142 / AR 401 142 / AR 403 122
Compatible with (air recirculation):	2x AR 413 122 / 2x AR 410 110	AR 413 122
Dimensions		
Height of overall frame	(cm) 0.3	0.3
Surface mounting / flush mounting	• / •	• / •
Extending height	(cm) 33	33
Width on worktop	(cm) 118.4	90.8
Width in lower cabinet	(cm) 113.6	86
Depth on worktop	(cm) 14	14
Height in lower cabinet	(cm) 55–86	55–86
Net weight	(kg) 46	38
Consumption data according to EU regulation 65 / 2014		
Energy efficiency class		A ^{*2}
Energy consumption	kWh/year	45.5 ²
Ventilation efficiency class		A ^{*2}
Illumination efficiency class		C ^{*2}
Grease filter efficiency class		B ^{*2}
Sound level min. / max. normal mode	dB(A)	45/61 ²
Air extraction performance (EN 61591) with fan units, power level 1 / 2 / 3 / Intensive	with 2 remote fan units	with 1 remote fan unit
Air extraction with AR 400 142 for inside installation	(m ³ /h) at 5 Pa 540/820/1020/1140	310/485/600/765
Air extraction with AR 401 142 for outside wall mounting	(m ³ /h) at 5 Pa 550/800/1000/1200	295/450/560/660
Air extraction with AR 403 122 for plinth installation	(m ³ /h) at 5 Pa 560/750/980/1240	340/460/600/750
Air recirculation with AR 413 122 for plinth installation	(m ³ /h) at 0 Pa 610/845/1080/1375	310/425/555/715
Air recirculation with AR 410 110 for cupboard installation	(m ³ /h) at 0 Pa 740/890/1015/1210	
Air extraction ducting recommendation		
Equivalent ducting length Lmax	(m) 19	19
Features		
Power levels	3 plus intensive	3 plus intensive
Automatic function	–	–
Run-on function	(min) •/6 min.	•/6 min.
Interval ventilation	(min) •/6 min.	•/6 min.
Grease filter saturation indicator	•	•
Grease filter art	Cartridge-type filter	Cartridge-type filter
Grease filter units	3	2
Grease drain channel	•	•
Art of lighting	LED	LED
Lamp output	(W) 2 x 10	2 x 10
Illuminance	(lx) 400	400
Lighting colour	(Kelvin) 3600	3600
Air connection bottom / front / back side	• / • / •	• / • / •
Air connection piece DN 150 round duct (front/back side)	AD 754 049 ¹	AD 754 049 ¹
Air connection piece DN 150 flat duct (bottom side)	AD 854 050 ¹	AD 854 050 ¹
Connecting cable length	(m) 1.75	1.75
Cooktop-based ventilation control	–	–
Home network integration for digital services (Home Connect) wireless via WiFi.	–	–
Connection		
Total connected load	(W) depending on fan unit	depending on fan unit
Radio frequency interference-suppressed	•	•

• Standard. – Not available.

¹ Necessary installation accessory.

² Values refers to the configuration AL 400 with the remote fan unit AR 400 142.

* Energy efficiency class: at a range of energy efficiency classes from A+++ to D.

Ventilation, Illumination, Grease filter efficiency : at a range of classes from A to G.



Appliance type	Island hood	Island hood
Gaggenau Black	AL 200 180	AL 200 190
Air extraction / air recirculation	• /Air recirculation module as accessory	• /Air recirculation module as accessory
Dimensions with chimney		
Width	(cm) 80	90
Surface mounting / flush mounting	with AA 200 900 / •	with AA 200 900 / •
Extending height	(cm) 25	25
Width in worktop	(cm) 79.2	85.4
Depth in worktop	(cm) 14	14
Width in lower cabinet	(cm) 77.9	85.4
Height in lower cabinet surface	(cm) 70.3	70.3
Net weight	(kg) 37	43
Consumption data according to EU regulation 65/2014		
Energy efficiency class	A *	A *
Energy consumption	kWh/year 36.9	37.8
Ventilation efficiency class	A*	A*
Illumination efficiency class	–	–
Grease filter efficiency class	B*	C*
Sound level min. / max. normal mode	dB(A) 39/62	41/62
Air extraction performance (EN 61591), power level 1 / 2 / 3 / Intensive		
Air extraction	(m ³ /h) at 5 Pa	223/378/501/775
Air recirculation	(m ³ /h) at 0 Pa	170/362/447/562
Max. back pressure at 0 m ³ /h	(Pa)	
Sound power level (EN 60704-3) max/ Int		
Air extraction mode	(dB(A) re 1 pW)	62/70
Air recirculation mode	(dB(A) re 1 pW)	65/70
Air extraction ducting recommendation		
Equivalent ducting length Lmax	(m)	28
Features		
Power levels	3 plus intensive	3 plus intensive
Automatic function	•	•
Run-on function	(min) • / integrated	• / integrated
Interval ventilation	(min) –	–
Grease filter saturation indicator	•	•
Activated charcoal filter saturation indicator	•	•
Grease filter art	Cartridge-type filter	Cartridge-type filter
Grease filter units	2	2
Grease drain channel	•	•
Ambient lighting	•	•
Exhaust air connection piece	(ø mm) 150	150
Exhaust air connection, bottom / side / rear / front	• / - / - / -	• / - / - / -
Fan output	(W) 300	300
Connecting cable length	(m) 1.3	1.3
Cooktop-based ventilation control	• ¹	• ¹
Home network integration for digital services (Home Connect) wireless via WiFi. ²	•	•
Accessories		
Kit for surface mounted installation	AA 200 900	AA 200 900
Installation kit for fan unit at a distance	AA 200 910	AA 200 910
Installation kit for installation in a single worktop cut out	VA 200 080	VA 200 090
Air recirculation module	AA 200 880	AA 200 890
Activated charcoal filter (order as spare parts)	Part No. 17005381	Part No. 17005381
Regenerable air recirculation module	AA 200 882	AA 200 892
Connection		
Total connected load	(W) 300	300
Radio frequency interference-suppressed	•	•

• Standard. – Not available.

¹ Via Home Connect; in combination with suitable cooktop.

² The use of the Home Connect functionality depends on the Home Connect services, which are not available in every country.

* Energy efficiency class: at a range of energy efficiency classes from A+++ to D.
Ventilation, Illumination, Grease filter efficiency : at a range of classes from A to G.

Downdraft ventilation 400 series and Downdraft ventilation 200 series



Appliance type	Downdraft	Downdraft
Stainless steel	VL 414 115	–
Respective knob (Stainless steel / Black) ⁵	CKV 410 010 / CKV 410 000	–
Gaggenau Black	–	VL 200 120
Air extraction / air recirculation	•/•	•/•
Compatible with (air extraction):	AR 400 142 / AR 401 142 / AR 403 122	AR 403 122 / AR 400 142 / AR 401 142
Compatible with (air recirculation):	AR 413 122 / AR 410 110	AR 413 122 / AR 410 110
Dimensions		
Height of overall frame	(cm) 0.3	–
Surface mounting / flush mounting	•/•	•/–
Width on worktop	(cm) 15.5	15
Depth on worktop	(cm) 52	51.2
Height in lower cabinet surface mounting / flush mounting	(cm) 17.5/17.8	17.5/–
Net weight	(kg) 7	7
Consumption data according to EU regulation 65 / 2014		
Energy efficiency class	A⁺ ^{*1}	A ^{*2}
Energy consumption	kWh/year 40.4 ¹	48.3 ²
Ventilation efficiency class	A*	A*
Illumination efficiency class	–	–
Grease filter efficiency class	B*	B*
Sound level min. / max. normal mode	dB(A) 57/71 ¹	56/71 ¹
Air extraction performance (EN 61591) with fan units, power level 1 / 2 / 3 / Intensive		
	1 x VL 414	
Air extraction with AR 400 142 for inside installation	(m ³ /h) at 5 Pa 280/430/540/640	280/440/545/645
Air extraction with AR 401 142 for outside wall mounting	(m ³ /h) at 5 Pa 300/455/570/660	305/460/575/660
Air extraction with AR 403 122 for plinth installation	(m ³ /h) at 5 Pa 320/420/550/690	320/430/555/690
Air recirculation with AR 413 122 for plinth installation	(m ³ /h) at 0 Pa 290/390/520/660	305/410/530/665
Air recirculation with AR 410 110 for cupboard installation	(m ³ /h) at 0 Pa 350/415/490/590	360/435/500/595
Air extraction ducting recommendation		
Equivalent ducting length Lmax	(m) 26	26
Features		
Power levels	3 plus intensive	3 plus intensive
Automatic function	•	•
Run-on function	•	•
Interval ventilation	(min) • / 6 min.	• / 6 min.
Grease filter saturation indicator	•	•
Activated charcoal filter saturation indicator	•	•
Grease filter art	Metal grease filter	Metal grease filter
Grease filter units	1	1
Grease drain channel	•	•
Exhaust air connection bottom / side / back	–/–/•	–/–/•
Flexibel connecting piece DN 150 flat	AD 410 040 ²	AD 410 040 ²
Connecting piece for extension with flat duct DN150	AD 851 041 ²	AD 851 041 ²
Connecting cable length	(m) 1.75	1.7
Cooktop-based ventilation control	• ³	–
Home network integration for digital services (Home Connect) wireless via WiFi.	• ⁴	–
Connection		
Total connected load	(W) depending on fan unit	depending on fan unit
Radio frequency interference-suppressed	•	•

• Standard – Not available

¹ Values refers to the configuration VL 414 / VL 200 with the remote fan unit AR 403 122.

² Installation accessory

³ Via Home Connect; in combination with suitable cooktop

⁴ The use of the Home Connect functionality depends on the Home Connect services, which are not available in every country.

⁵ The knob must be ordered separately.

* Energy efficiency class: at a range of energy efficiency classes from A+++ to D.
Ventilation, Illumination, Grease filter efficiency : at a range of classes from A to G.



Appliance type		Wall-mounted hoods
Stainless steel		AW 442 120
Air extraction / air recirculation		• / •
Compatible with (air extraction):		AR 400 142 / AR 401 142 / AR 400 143
Compatible with (air recirculation):		AR 400 143 and AA 442 810
Dimensions with chimney		
Width	(cm)	120
Depth	(cm)	55
Height, air extraction / air recirculation, min.–max.	(cm)	72–150
Net weight, min.–max.	(kg)	32
Weight air extraction duct, min.–max.	(kg)	7–11
Consumption data according to EU regulation 65 / 2014		
Energy efficiency class		A ^{*1}
Energy consumption	kWh/year	48.1 ¹
Ventilation efficiency class		A* ¹
Illumination efficiency class		B* ¹
Grease filter efficiency class		B* ¹
Sound level min. / max. normal mode	dB(A)	47/64 ¹
Air extraction performance (EN 61591) with fan units, power level 1 / 2 / 3 / Intensive		
Air extraction with AR 400 142 for inside installation	(m ³ /h) at 5 Pa	315/490/615/755
Air extraction with AR 400 143 for chimney of AI / AW 442	(m ³ /h) at 5 Pa	325/505/615/885
Air extraction with AR 401 142 for outside wall mounting	(m ³ /h) at 5 Pa	320/485/615/720
Air recirculation with AR 400 143 for chimney of AI / AW 442	(m ³ /h) at 0 Pa	290/455/565/775
Air extraction ducting recommendation		
Equivalent ducting length Lmax	(m)	26
Features		
Power levels		3 plus intensive
Automatic function		•
Run-on function	(min)	• / integrated
Interval ventilation	(min)	–
Grease filter saturation indicator		•
Grease filter art		Baffle filter
Grease filter units		4
Grease drain channel		•
Art of lighting		LED
Lamp output	(W)	3 x 10
Illuminance	(lx)	940
Lighting colour	(Kelvin)	3500
Exhaust air connection piece	(ø mm)	150
Exhaust air connection piece, top / side / rear / front S = specially produced		• / S / S / S
Connecting cable length	(m)	1.75
Cooktop-based ventilation control		–
Home network integration for digital services (Home Connect) wireless via WiFi.		–
Minimum clearance above cooking position		
For gas appliances with total connected load gas of less / more than 12 kW	(cm)	70
For electric appliances	(cm)	60
Connection		
Total connected load	(W)	depending on fan unit
Radio frequency interference-suppressed		•

¹ Values refers to the configuration AW 442 with the remote fan unit AR 400 143.

* Energy efficiency class: at a range of energy efficiency classes from A+++ to D.
Ventilation, Illumination, Grease filter efficiency : at a range of classes from A to G.

Wall-mounted hoods 200 series and Island hoods 200 series



Appliance type	Wall-mounted hoods	Island hood
Stainless steel	AW 240 191	AI 240 191
Glass front in Gaggenau Anthracite		
Air extraction / air recirculation	• / Air recirculation module as accessory	• / Air recirculation module as accessory
Dimensions with chimney		
Width	(cm) 90	90
Depth	(cm) 50	60
Height, air extraction / air recirculation, min.–max.	(cm) 65-95/82-115	74-92/82-104
Net weight	(kg) 21	32
Weight air extraction duct		
Consumption data according to EU regulation 65 / 2014		
Energy efficiency class	A *	A *
Energy consumption	kWh/year 44.5	48,8
Ventilation efficiency class	A*	A*
Illumination efficiency class	A*	A*
Grease filter efficiency class	B*	B*
Sound level min. / max. normal mode	dB(A) 44/64	43/64
Air extraction performance (EN 61591), power level 1 / 2 / 3 / Intensive		
Air extraction	(m³/h) at 5 Pa 275/422/618/970	291/441/641/988
Air recirculation	(m³/h) at 0 Pa 185/321/383/476	195/362/448/530
Max. back pressure at 0 m³/h	(Pa) 459	436
Sound power level (EN 60704-3) max / Int		
Air extraction mode	(dB(A) re 1 pW) 64/73	64/72
Air recirculation mode	(dB(A) re 1 pW) 69/74	69/72
Air extraction ducting recommendation		
Equivalent ducting length Lmax	(m) 26	23
Features		
Power levels	3 plus intensive	3 plus intensive
Automatic function	•	•
Run-on function	(min) • / integrated	• / integrated
Interval ventilation	(min) • / 6 min.	• / 6 min.
Grease filter saturation indicator	•	•
Activated charcoal filter saturation indicator	•	•
Grease filter art	Cartridge-type filter	Cartridge-type filter
Grease filter units	3	3
Grease drain channel	-	-
Art of lighting	LED	LED
Lamp output	(W) 3 x 3	4 x 3
Illuminance	(lx) 551	650
Lighting colour	(Kelvin) 3500	3500
Colour range (adjustable with Home Connect)	(Kelvin) 2700 - 5000	2700 - 5000
Exhaust air connection piece	(ø mm) 150	150
Exhaust air connection piece, top / side / rear / front S = specially produced	• / S / S / S	• / S / S / S
Fan output	(W) 260	260
Connecting cable length	(m) 1.3	1.3
Cooktop-based ventilation control	• ¹	• ¹
Home network integration for digital services (Home Connect) wireless via WiFi. ²	•	•
Minimum clearance above cooking position		
For gas appliances with total connected load gas of less/more than 12 kW	(cm) 65/70	65/70
For electric appliances	(cm) 55	55
Accessories		
Air recirculation module	AA 200 812	AA 200 816
Regenerable activated charcoal filter	AA 200 112	AA 200 112
Activated charcoal filter (order as spare parts)	Part No. 11033934	Part No. 11033934
Chimney extension	AD 200 322	AD 200 326
Extension for mounting kit		AD 223 346
Ceiling collar	AD 200 392	AD 220 396
Chimney for air extraction		
Connection		
Total connected load	(W) 269	272
Radio frequency interference-suppressed	•	•

• Standard. – Not available.

¹ Via Home Connect; in combination with suitable cooktop.

² The use of the Home Connect functionality depends on the Home Connect services, which are not available in every country.

* Energy efficiency class: at a range of energy efficiency classes from A+++ to D.

Ventilation, Illumination, Grease filter efficiency : at a range of classes from A to G.



Appliance type	Flat kitchen hood	Flat kitchen hood
Stainless steel-coloured	AF 210 192	AF 210 162
Air extraction / air recirculation	• /Air recirculation module as accessory	• /Air recirculation module as accessory
Dimensions		
Width	(cm) 90	60
Depth	(cm) 32	32
Depth when steam screen extended	(cm) 48.8	48.8
Height	(cm) 37.8	37.8
Net weight	(kg) 17	15
Consumption data according to EU regulation 65 / 2014		
Energy efficiency class	A *	A *
Energy consumption	kWh/year 41.4	40.3
Ventilation efficiency class	A*	A*
Illumination efficiency class	A*	A*
Grease filter efficiency class	B*	B*
Sound level min. / max. normal mode	dB(A) 42/57	41/57
Air extraction performance (EN 61591), power level 1 / 2 / 3 / Intensive		
Air extraction	(m³/h) at 5 Pa 272/384/517/965	271/386/515/953
Air recirculation	(m³/h) at 0 Pa 267/372/506/876	266/364/497/885
Max. back pressure at 0 m³/h	(Pa) 434	455
Sound power level (EN 60704-3) max / Int		
Air extraction mode	(dB(A) re 1 pW) 57/71	57/71
Air recirculation mode	(dB(A) re 1 pW) 62/69	62/69
Air extraction ducting recommendation		
Equivalent ducting length Lmax	(m) 23	23
Features		
Glass screen	•	•
Arrangement of controls	Buttons at front	Buttons at front
Power levels	3 plus intensive	3 plus intensive
Automatic function	•	•
Run-on function	(min) • / integrated	• / integrated
Interval ventilation	(min) –	–
Grease filter saturation indicator	•	•
Grease filter art	Stainless steel grease filter	Stainless steel grease filter
Grease filter units	1	1
Grease drain channel	–	–
Art of lighting	LED	LED
Lamp output	(W) 3 x 3	2 x 3
Illuminance	(lx) 355	294
Lighting colour	(Kelvin) 3500	3500
Exhaust air connection piece	(ø mm) 150	150
Exhaust air connection piece, top / side / rear / front S = specially produced	• / - / - / -	• / - / - / -
Fans	(No.) 1	1
Fan output	(W) 260	260
Connecting cable length	(m) 1.75	1.75
Cooktop-based ventilation control	–	–
Home network integration for digital services (Home Connect) wireless via WiFi.	–	–
Minimum clearance above cooking position		
For gas appliances with total connected load gas of less / more than 12 kW	(cm) 65/70	65/70
For electric appliances	(cm) 43	43
Accessories		
Lowering frame	AA 210 492	AA 210 460
Assembly kit for 90 cm upper cabinet	AA 210 491	
Air recirculation module	AA 211 812	AA 211 812
Activated charcoal filter (order as spare parts)	Part No. 11034172	Part No. 11034172
Connection		
Total connected load	(W) 266	264
Radio frequency interference-suppressed	•	•

• Standard. – Not available.

* Energy efficiency class: at a range of energy efficiency classes from A+++ to D.
Ventilation, Illumination, Grease filter efficiency : at a range of classes from A to G.

Canopy extractors 200 series



Appliance type	Canopy extractor	Canopy extractor	Canopy extractor
Stainless steel-coloured	AC 200 191	AC 200 181	AC 200 161
Air extraction / air recirculation	•/Air recirculation module as accessory	•/Air recirculation module as accessory	•/Air recirculation module as accessory
Dimensions			
Width	(cm) 86	70	52
Depth	(cm) 28.2	30	30
Height	(cm) 36 (housing)	36 (housing)	36 (housing)
Net weight	(kg) 9.8	9.2	8.3
Consumption data according to EU regulation 65 / 2014			
Energy efficiency class	A++*	A++*	A++*
Energy consumption	kWh/year 31.4 kWh	30.3 kWh	29.6 kWh
Ventilation efficiency class	A*	A*	A*
Illumination efficiency class	A*	A*	A*
Grease filter efficiency class	D*	D*	D*
Sound level min. / max. normal mode	dB(A) 41/64	46/64	44/64
Air extraction performance (EN 61591), power level 1 / 2 / 3 / Intensive			
Air extraction	(m³/h) at 5 Pa 210/380/610/800	210/380/575/775	210/365/540/730
Air recirculation	(m³/h) at 0 Pa 200/360/540/790	200/360/540/740	200/360/530/690
Max. back pressure at 0 m³/h	(Pa) 560	560	560
Air extraction ducting recommendation			
Equivalent ducting length Lmax	19	19	19
Sound power level (EN 60704-3) max / Int			
Air extraction mode	(dB(A) re 1 pW) 64/70	64/70	64/70
Air recirculation mode	(dB(A) re 1 pW) 72/77	73/78	72/77
Features			
Infrared remote control	AA 200 510	AA 200 510	AA 200 510
Power levels	3 plus intensive	3 plus intensive	3 plus intensive
Automatic function	-	-	-
Run-on function	•/6 min.	•/6 min.	•/6 min.
Interval ventilation	•/6 min.	•/6 min.	•/6 min.
Grease filter saturation indicator	•	•	•
Grease filter art	Cartridges	Cartridges	Cartridges
Grease filter units	2	2	1
Grease drain channel	-	-	-
Art of lighting	LED	LED	LED
Lamp output	(W) 2 x 1	2 x 1	2 x 1
Illuminance	(lx) 266	244	244
Lighting colour	(Kelvin) 4000	4000	4000
Exhaust air connection piece	(ø mm) 150/120	150/120	150/120
Exhaust air connection piece, top / side / rear / front S = specially produced	•/-/-/-	•/-/-/-	•/-/-/-
Fans	(No.) 1	1	1
Fan output	(W) 170	170	170
Connecting cable length	(m) 1	1	1
Cooktop-based ventilation control	-	-	-
Home network integration for digital services (Home Connect) wireless via WiFi.	-	-	-
Minimum clearance above cooking position			
For gas appliances with total connected load gas of less / more than 12 kW	(cm) 65/70	65/70	65/70
For electric appliances	(cm) 65	65	65
Accessories			
Air recirculation module	AA 211 812	AA 211 812	AA 211 812
Activated charcoal filter (order as spare parts)	Part No. 11034172	Part No. 11034172	Part No. 11034172
Connection			
Total connected load	(W) 172	172	172
Radio frequency interference-suppressed	•	•	•

• Standard. – Not available.

* Energy efficiency class: at a range of energy efficiency classes from A+++ to D.

Ventilation, Illumination, Grease filter efficiency : at a range of classes from A to G.



Appliance type	Inside	Inside	Outside wall	Plinth	Plinth	Inside
Stainless steel			AR 401 142			
Metal zinc plated	AR 400 142	AR 400 143		AR 403 122	AR 413 122	AR 410 110
Air extraction / air recirculation	•/–	•/–	•/–	•/–	–/•	–/•
Dimensions						
Width	(cm) 42.6	33.3	42.2	45.1	40.6	42.8
Depth	(cm) 42.6	24	45.3	50.5	53.5	22.8
Height	(cm) 23.2	23.2	14	9.5	9.9	52
Net weight	(kg) 14	5	14	9	9	12
Installation possibility						
Slanted roof (not Eternit)			•			
Outside wall			•			
Inside wall	•			•	•	•
Bottom cupboard	•			•	•	•
Chimney hood AI / AW 442		•				
Attic	•			•		
Cellar	•			•		
Air extraction performance (EN 61591) with fan units, power level 1 / 2 / 3 / Intensive						
Air extraction (up to)	(m³/h) at 0 Pa	880	1065	1200	965	
Air recirculation (up to)	(m³/h) at 0 Pa					900
Max. back pressure at 0 m³/h	(Pa)	500	480	640	770	610
Features						
Power levels	3 plus intensive	3 plus intensive	3 plus intensive	3 plus intensive	3 plus intensive	3 plus intensive
Fan technology	BLDC	BLDC	BLDC	BLDC	BLDC	BLDC
Fans	(No) 1	1	1	1	1	1
Fan output	(W) 240	230	180	180	180	170
Sound insulation	•	•	•	–	–	•
Retaining bracket	•	–	•	•	•	•
Pipe connection piece intake side	(ø mm) 5 x 150		1 x 200	1 x 150	1 x 150	1 x 150 flat
Pipe connection piece output side	(ø mm) 1 x 150	1 x 150		1 x 150 flat		
Spare cover for closing air intake	•	–	–	–	–	–
Activated charcoal filter (order as spare parts)	–	–	–	–	Part No. 17003002	Part No. 11028106
Connecting cable length	(m) 1.75	–	1.75	1.75	1.75	1.75
Network cable length	(m) 5	–	5	2	2	2
Ratings in combination with extraction element						
Radio frequency interference-suppressed	•	•	•	•	•	•

• Standard. – Not available.

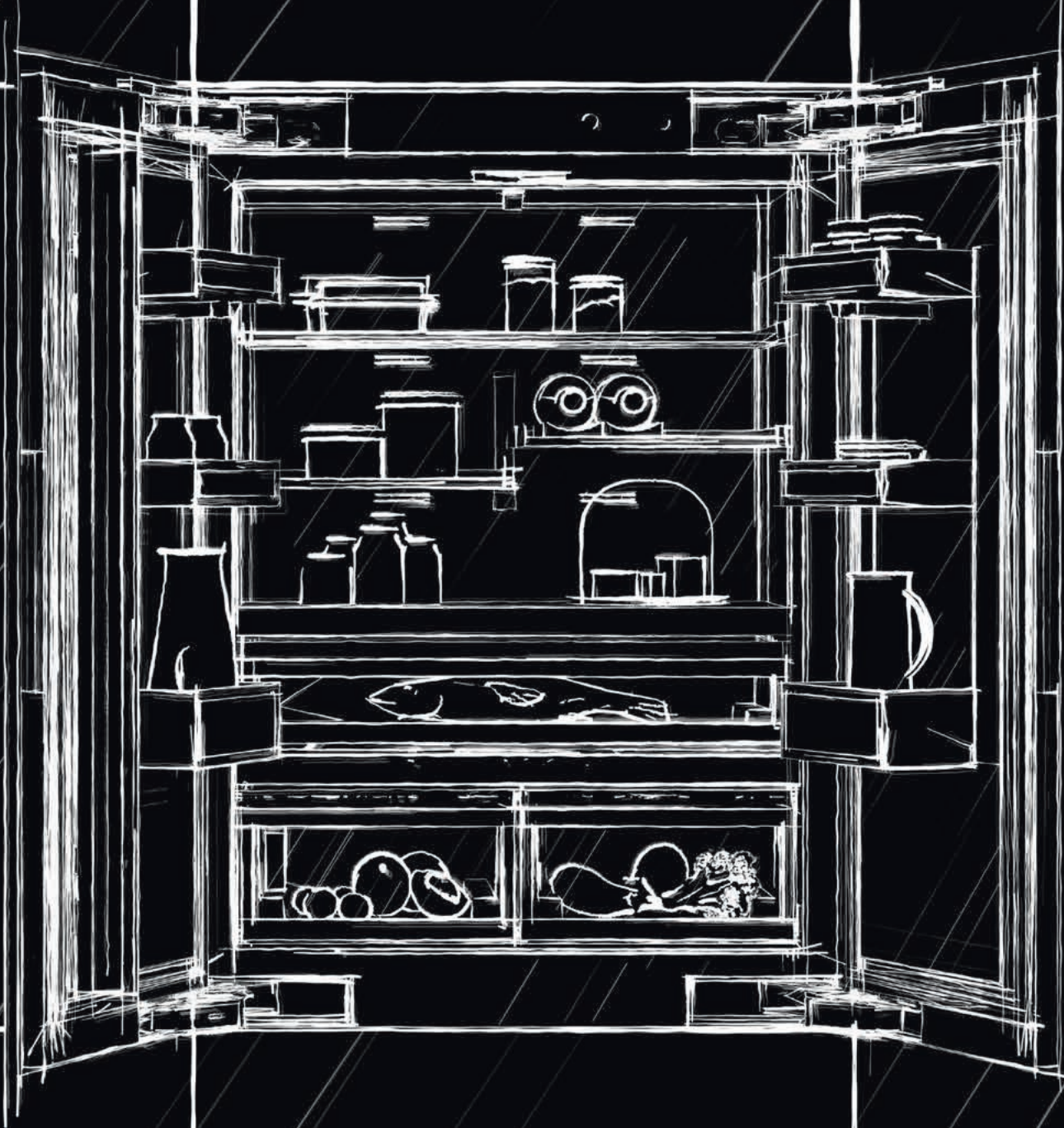

The cooling appliances

Overview	306
The new generation of cooling	310
Vario cooling 400 series: Cooling, freezing and wine	316
Planning notes Vario cooling 400 series	328
Vario cooling 200 series: Cooling and freezing	336
Cooling appliances 200 series	340
Planning notes Vario cooling and cooling 200 series	349
Wine	350
Accessories special accessories	358
Technical specifications	370

Overview

The new generation of cooling

Niche 213 cm

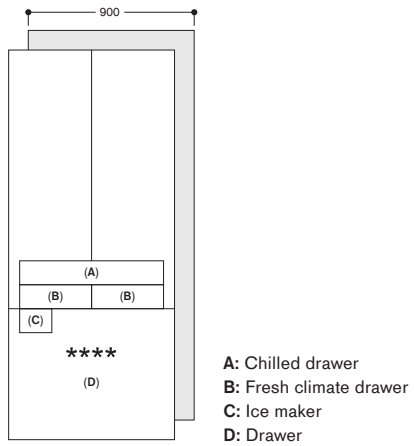

RVY 497

Vario cooling 400 series

Niche 213 cm

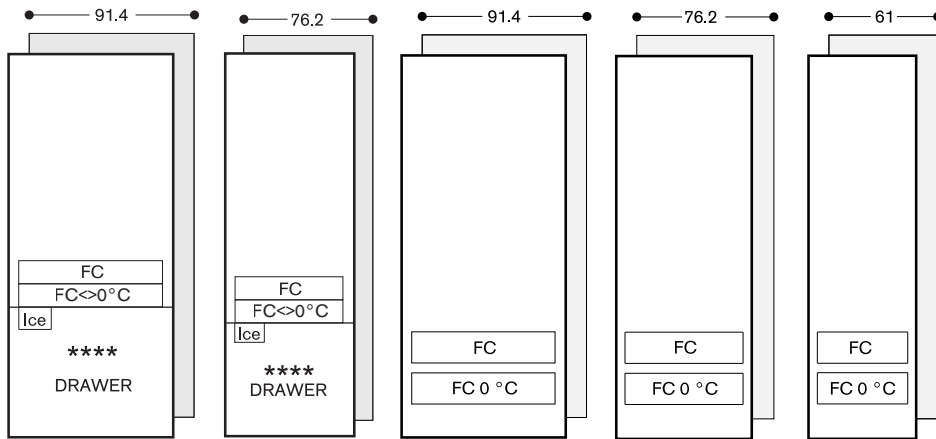

RB 492

RB 472

RC 492

RC 472

RC 462

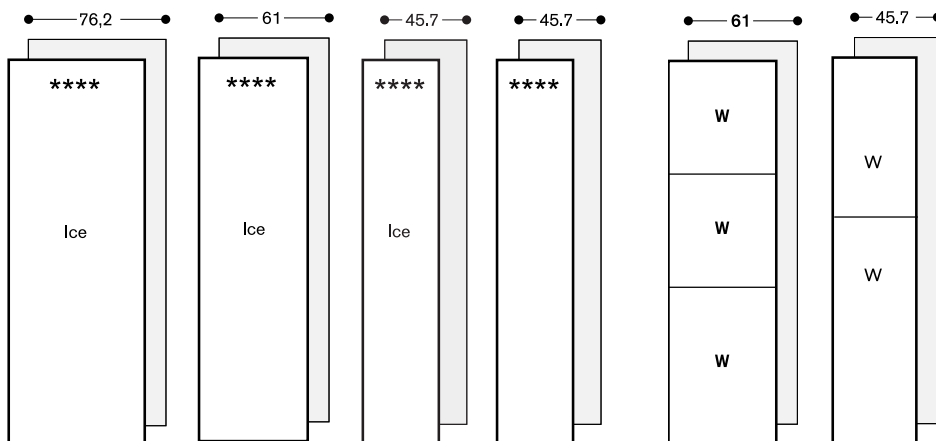

RF 471

RF 461

RF 411

RF 410

RW 466

RW 414

Vario cooling 200 series

Niche 178 cm

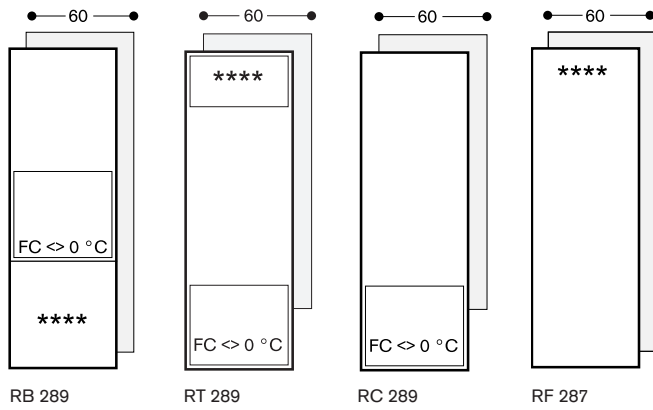

FC: Fresh cooling
 FC $\lt; 0^\circ\text{C}$: Fresh cooling close to 0°C
 FC 0°C : Fresh cooling 0°C
 W: Wine
 Ice: Ice maker

Overview

Cooling 200 series

Freestanding / Height 183 cm

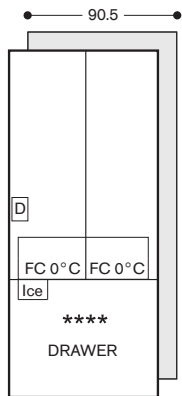

RY 295

Niche 178 cm

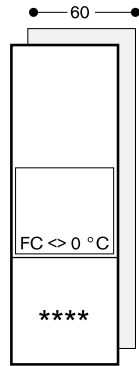

RB 282

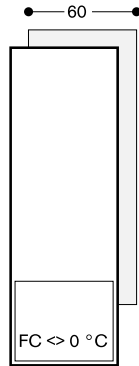

RC 282



RT 282

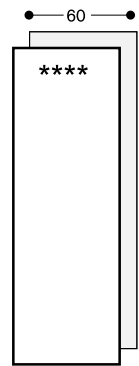

RF 282

Niche 82 cm / Under-counter

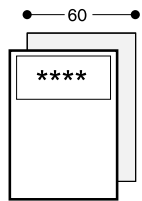

RT 202

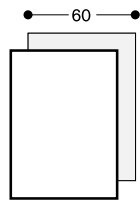

RC 202

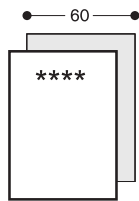

RF 202

Wine climate cabinet

Niche 213 cm

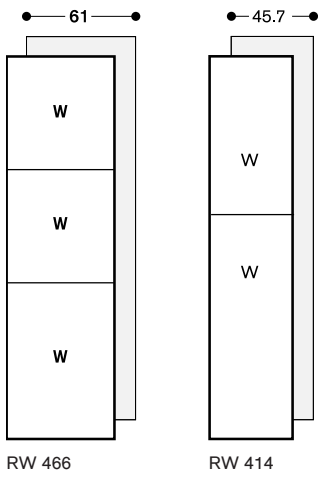

Niche 178 cm

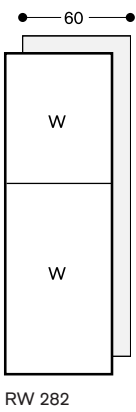

Niche 123 cm

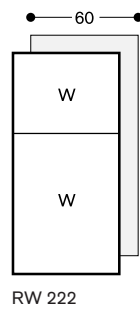

Niche 82 cm / Under-counter

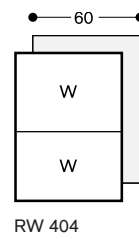



RVY 497 190

Fully integrated
Niche width 90 cm,
Niche height 213.4 cm
Cooling compartment with two doors
and one fully extendable freezing
drawer



Included in the price

- 1 egg holder with lid
- 1 ice cube scoop
- 2 wooden bottle holder magnetic
- 2 bottle supports, oak wood

Installation accessories

RA 425 110

Handle bar, stainless steel, long
With 3 mounts, length 1.131 mm,
height 49 mm, drilling distance
between each mount 554 mm.

RA 425 910

For RVY 497, RB 492 and RW 222,
with 2 mounts, length 810 mm, height
49 mm, drilling distance between the
mounts 787 mm.

RA 460 030

Connecting element for vertically split
fronts (for fridge-freezer combination).

RVA 421 922

Door panels, dark brushed stainless
steel, with handles
For RVY 497, panel thickness 19 mm.

RVA 423 141

Side trims, 3 mm. 2 pieces.

RVA 428 922

Door panels, dark brushed stainless
steel, handleless
For RVY 497, panel thickness 19 mm.

RA 460 000

Accessory for side-by-side installation
For RVY 497.

RVA 460 020

Accessory for side-by-side installation,
backward compatible
Required if a RVY 497 is installed
side-by-side with a RY, RB, RC, RF or
RW of the Vario cooling 400 series.

RVA 460 900

Accessory for replacement side-by-side
installation in unmodified niche
Required if a RVY 497 (89.4 cm wide)
is installed side-by-side into a niche
which was formerly housing a
combination including a RY 492,
RB 492 or RC 492 (90.8 cm wide).

RVA 460 910

Accessory for replacement in single
unmodified niche
Required if a RVY 497 (89.4 cm wide)
is replacing a RY 492, RB 492 or
RC 492 (90.8 cm wide).

Fridge-freezer combination dark brushed stainless steel RVY 497

- Dark brushed stainless steel interior, refined with solid anthracite aluminium elements
- Warm white and glare-free LED light concept for optimal food presentation in all compartments
- Opening assist for door enabling seamless integration without handles
- Flat dark brushed stainless steel inner door
- Flexible positioning of shelves and door racks through hidden rail system
- Solid anthracite aluminium door racks
- Professional freshness system with 2 fresh climate drawers and 1 chilled drawer
- Integrated ice maker with fixed water connection
- Spacious, fully extendable freezer compartment including 2 additional interior drawers
- Full touch TFT display
- Total volume: 575 litres

Handling

Opening assist for door.
Cushioned door closing system.
Light and display response to drawer interaction.
Automatic brightness adjustment based on ambient illumination.
Easy accessible full touch TFT display.
Clear text display.
Animated quick guides to assist appliance maintenance.

Technical features

Dynamic cold air distribution.
Automatic defrosting with defrost water evaporation.
Constant air purification by 2 activated charcoal air filters.
Open-door and malfunction alarm.

Selected digital services (Home Connect)

Storage management with cameras.
Personalisation function for saving custom programmes.
Remote control and monitoring.
Remote diagnostics.

Please read additional information on Home Connect on page 411.

Cooling

Professional freshness system.
No-Frost technology with fast cooling.
Temperature adjustable from +2 °C to +8 °C.
3 aluminium-framed safety glass shelves, individually adjustable in height.
1 integrated safety glass shelf with satin matte finish.
Optimal food presentation with warm white and glare-free, hidden LED light bars (3000 K).
Flexible positioning of door racks through hidden rail system.
6 door racks, thereof 4 height adjustable.
Total volume of all refrigerator compartments: 320 litres.

Fresh climate drawer

2 fresh climate drawers with humidity control.
Temperature adjustable from -1 °C to +2 °C.

Special accessories

ACLETHRF10

Ethylene absorber
Refill kit.

For placement in a fresh climate drawer.

ACLETHST10

Ethylene absorber
Starter kit.

For placement in a fresh climate drawer.

RA 430 100

Storage container with transparent lid, anthracite.

RA 450 012

Activated charcoal water filter
For RVY, RY, RB and RF.

RVA 438 040

Solid oak wood bottle support with magnetic connector.

RVA 450 220

Activated charcoal air filter.

Ideal storage conditions for different foods through dedicated programmes (e.g. Fruit, Vegetables, Meat).
Individual adjustment of temperature and humidity.
Extended food preservation with ethylene absorber.
Indirect illumination, transparent front.
Fully extendable, with cushioned closing system.

Chilled drawer

Temperature dependent on cooling compartment (always 2K to 3K lower).
Indirect illumination, transparent front.
Fully extendable, with cushioned closing system.

Freezing

No-frost technology with fast freezing at -30 °C.
4-star freezer compartment.
Temperature adjustable from -24 °C to -16 °C.
Freezer burn protection.
Oxidation protection.
Freezing capacity 13 kg/24 h.
Storage time after malfunction 10 h.
Spacious, fully extendable freezer compartment with synchronously running pull-out rails.
2 extendable interior drawers.
Warm-white, glare-free LED lighting (3000 K) within freezer compartment.
Total volume of freezer compartment: 197 litres.

Ice maker

Integrated in the freezer compartment, with fixed water connection (inlet).
Can be switched off.
Particle filter for water inlet, integrated in ventilation grille area.
Saturation indicator for filter via full touch TFT display.
Ice cube production approx. 3 kg/24 h.
Removable ice storage container with approx. 3 kg capacity.
Integrated, easy accessible ice cube scoop.

Consumption data

Energy efficiency class D at a range of energy efficiency classes from A to G.
Energy consumption 275 kWh/year.
Noise level 39 dB (A) re 1 pW.

Planning notes

Flat hinge.
Door hinge right, reversible.
Door opening angle of 115°, fixable at 90°.
Max. door panel weight:
Each door 64 kg.
Drawer 14 kg.
When rest mode is active, the appliance can only be opened using a handle.
Shut-off valve for water connection must be planned next to the appliance and always be accessible.
If the water pressure exceeds 0.8 MPa (8 bar), connect pressure relief valve between water tap and hose set.

Please read additional planning notes on page 312 – 315.

Connection

Total connected load 0.200 kW.
Connecting cable 3.0 m, pluggable.
Water inlet.
Supply hose 2.8 m with 3/4" connection.
Water pressure 2 to 8 bar.

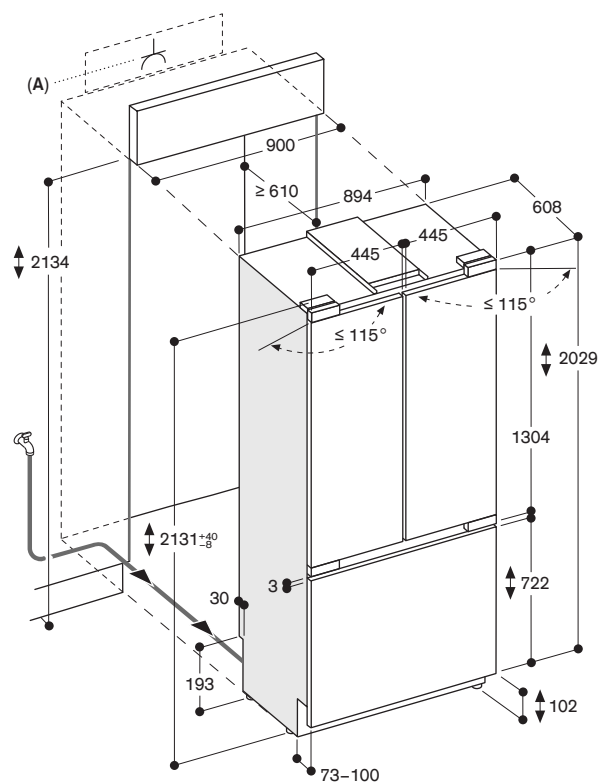

A: Socket

The maximum door panel dimensions are based on a clearance of 3 mm

The height of the plinth can be reduced to 50 mm

Measurements in mm

Additional planning notes for dark brushed stainless steel fridge-freezer combination RVY 497

The side walls of the adjacent cabinetry have to be dimensionally stable, as the cooling appliances are secured in the niche with only an anti-tilt bracket on the top back and on the bottom at the side.

The cooling appliances can be installed handle to handle as a side-by-side combination. In this case the side-by-side installation kit RVA 460 000 is required. If the cooling appliances are joined together hinge to hinge an additional stable side wall must be foreseen. If restrictions in use are accepted, (a simultaneous opening of the doors is not possible) the appliances can be joined directly, using the side-by-side installation kit RVA 460 000.

When installing a cooling appliance handleless next to a BO/BM/BS/CM from the oven 400 series a minimum lateral distance of 30 mm is required, if the door of the cooling appliance opens towards the BO/BM/BS/CM. If the BO/BM/BS have a retrofitted handle on the same side as the cooling appliance's door hinge a lateral distance of 60 mm is required.

For the same installation next to a BOP/BMP/BSP from the ovens 200 series, a distance of 40 mm is required.

Door opening angle

To ensure correct kitchen planning it is essential to take into account the opening angle of the appliance's door plus the door panel and handle. Collisions with kitchen furniture (worktops, handles of adjacent cabinetry, etc.) or parts of the room (walls, protrusions, etc.) need to be avoided.

The necessary space for the hinge movement and the resulting clearances, depending on the door opening angle, to adjacent cabinetry and its handle are shown in the following drawing. The clearances are based on a door panel thickness of 19 mm.

In case of a potential collision, the following options are available to solve the situation:

- Limit the door opening angle to 90° (standard 115°). A pin to limit the opening is enclosed with the appliance
- Fit a spacer between the appliance and the cabinetry that it would collide with
- Rearrange surrounding cabinetry or appliance

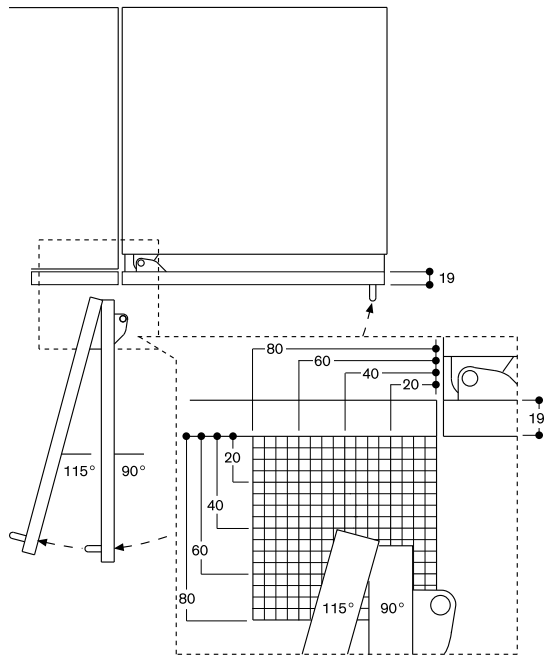

The hinge travel and resulting clearances from adjacent furniture units and handles can be found from the drawing while allowing for the thickness of the front panel. In the drawing, a furniture unit front panel thickness of 19 mm was assumed.

Wall clearance fridge-freezer combination

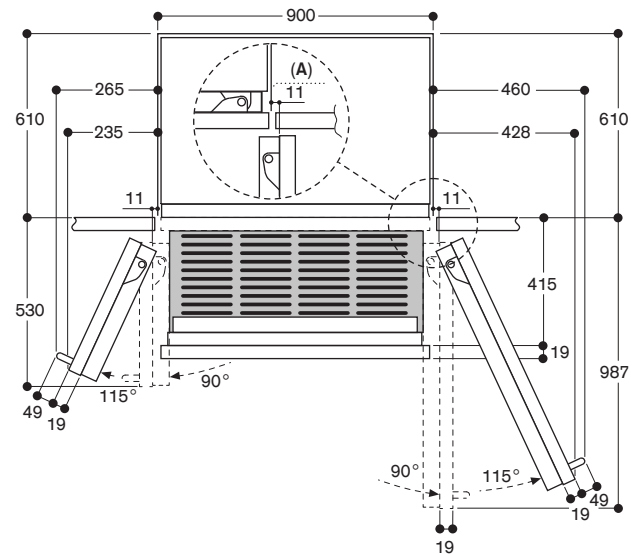

A: Recess

The clearances are based on a door panel thickness of 19 mm and a Gaggenau handle with a height of 49 mm

Measurements in mm

Unlike conventional built-in appliances, the appliance stands on the floor. Therefore the installation niche is a space in a line of kitchen units.

Installation niche

The specified dimensions of the installation niche must be ensured to guarantee a proper installation of the appliance and a seamless integration into the kitchen design. It is particularly important that the installation niche is square. The side walls must be smooth, not uneven and without protrusions. Use the appropriate tools, e.g. spirit level, diagonal measurements, etc. to determine whether the installation niche is square.

The side walls and the crown of the installation niche must be at least 16 mm thick.

The anti-tip bracket must be installed at the standard installation height of 2134 mm. If the niche exceeds this height, the anti-tip bracket must be installed at the highest point of the niche and the appliance then raised to match the niche height.

Installation niche for an individual appliance

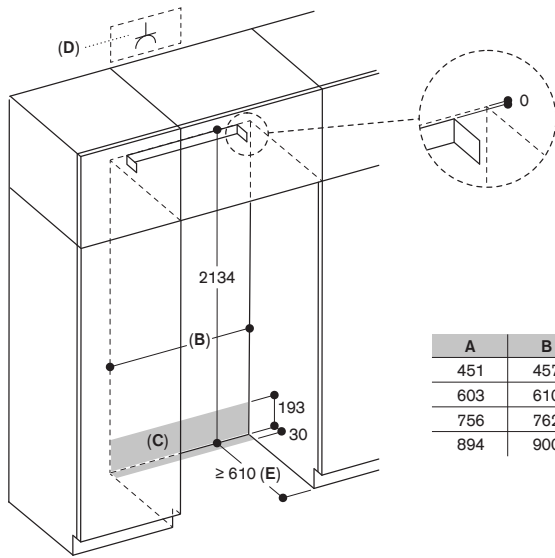

- A: Appliance width
- B: Width of installation niche
- C: Area for guiding water supply hose
- D: Socket
- E: Depth of installation niche, depending on kitchen design

Measurements in mm

Installation niche for a side-by-side solution

The cooling appliances offer options for side-by-side combinations to create an individual kitchen design. The required width of the installation niche is the sum of the widths of the single appliances. Height and depth of the installation niche correspond to the specifications of the single appliances.

It is important to comply with the specified dimensions to ensure enough space for the electrical and water connection. For precise dimensions, please refer to the details given for the single appliances.

Location

The appliance should be installed in a dry and well-ventilated room. The location of the appliance should not be subject to direct sunlight or be near a heat source, such as a cooker, a radiator, etc.

If an installation next to a heat source is unavoidable the following minimum distances to that source need to be considered:

- 3 cm to electric or gas cookers
- 3 cm to electric or gas ovens
- 30 cm to an oil-fired or solid-fuel cooker

Surface

To ensure that the appliance is installed securely and functions properly, the floor must be level and even. Moreover, it must consist of a hard, rigid material and not give way, due to the heavy weight of a fully loaded appliance. The following table shows the resulting weight of an appliance when installed with a door panel having the max. permitted weight and being fully loaded.

Maximum load weight

Model	Description	Max. panel weight
RVY497	Fridge-freezer combination 89.4 cm, 3 doors	583.6 kg

In case of doubt, consult an architect, structural engineer or construction expert. If required the floor must be reinforced. To ensure the proper functionality of the ice maker the appliance must be upright.

Neighbouring cabinetry

The appliance is securely positioned into its niche by screwing it firmly to the adjacent and top cabinetry. It must be ensured that all cabinetry onto which the appliance is fastened, is firmly connected to the floor or the wall. The thickness of the skirting board can be max. 19 mm.

Plinth area

Important!
 Poor ventilation damages the appliance!
 It is not permitted to cover the air inlets and the exhaust air outlets of the appliance in the plinth area.
 Based on the standard installation height the plinth height is 102 mm (the distance between the floor and the bottom edge of the door panel installed on the appliance) to ensure a proper operation of the appliance. Take this into consideration also when adjusting the feet of the appliance.

Plinth area

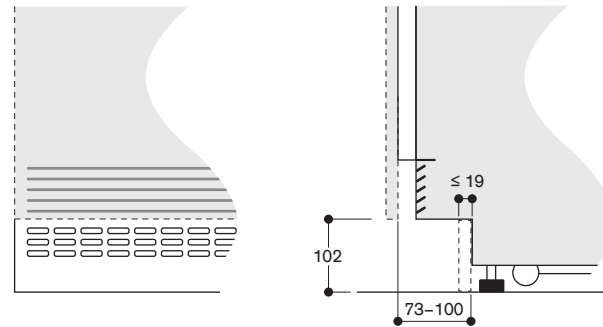

Based on the standard installation height, the height of the plinth is 102 mm

The height of the plinth can be reduced to 50 mm

Maximum skirting board thickness 19 mm

Measurements in mm

For design reasons, it may be necessary to decrease the plinth height. It can be reduced to 50 mm. Subsequently the height of the skirting board (C) needs to be reduced as well to match the now lower plinth height, so the additional ventilation openings (B) are not fully covered. Only then, a proper operation of the appliance can be guaranteed.

E.g. Plinth height: 70 mm. The skirting board shall not be higher than 70 mm. Adhesive connectors on the appliance ensure a secure fixation of the skirting board.

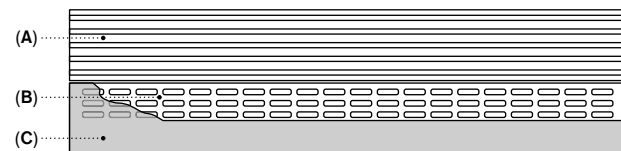

- A: Air inlets and exhaust air outlets
- B: Ventilation openings in skirting board area
- C: Skirting board

The height of the plinth can be reduced to 50 mm based on the standard installation height. The skirting board height needs to be reduced to match the plinth height to allow for the additional ventilation.

Special accessories | Replacement

Crown

Important!

The crown of the installation niche must always have a depth of at least 102 mm (measured from the front edge of the appliance) and be at least 16 mm thick. Only then a secure installation of the appliance in the niche can be guaranteed.

The height of the door panel on the appliance is dependent on:

- The overall height of the appliance
- The distance from the bottom edge of the door panel to the floor
- The appliance type (one-door or multi-door appliances)

This height may vary depending on the installation conditions. For design reasons it may be necessary to lengthen the cabinet door upwards by extending it beyond the top of the appliance.

Dimensions of special accessories – door panels

The cabinetry, the height of the plinth, the overall height of the kitchen and other determining dimensions of the kitchen must be considered in order to plan the exact positioning of the door panel, so that the appliance integrates perfectly into the overall kitchen design.

The following drawings show the basic dimensions of the special accessory door panels.

These are designed to fit the following basic specifications:

- Height of the plinth: 102 mm
- Overall height of the installation niche: 2134 mm
- Gaps: 3 mm
- Door panel thickness: 19 mm

Important!

The following drawings are not a substitute for detailed designs. Compliance with specified requirements relating to kitchen design is essential.

Niche width 900 mm

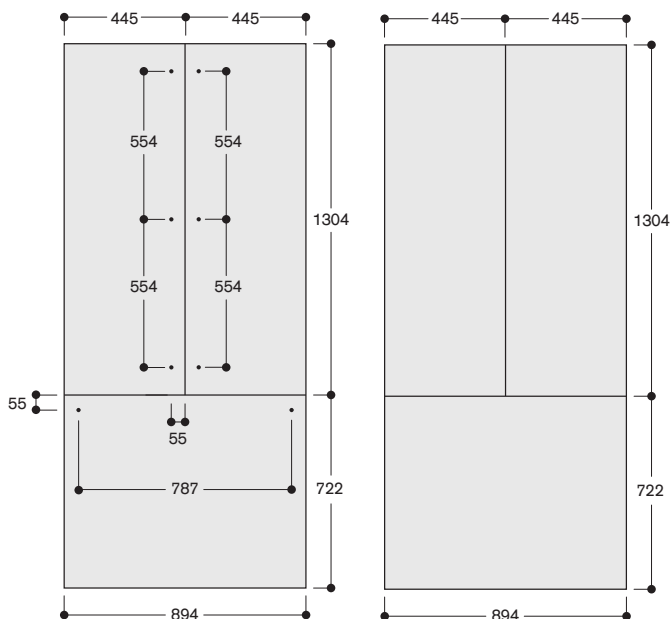

The door panel thickness is 19 mm

The maximum door panel dimensions are based on a clearance of 3 mm, based on a single niche

Measurements in mm

When designing custom door panels ensure the maximum panel weights shown in the following table are not exceeded.

Maximum permitted door panel weight

Model	Description	Max. panel weight
RVY497	Fridge-freezer combination 89.4 cm, 3 doors	Each door 64 kg / Drawer 14 kg

Replacement of RVY497 into 914 mm niche

If a RVY 497 is installed into an existing, unmodified 914 mm wide niche (e.g. replacement of an appliance of the Vario cooling 400 series - RY 492) be aware of the following dimensional changes:

- Appliance width 894 mm (compared to 908 mm within Vario cooling 400 series)
- Range of height adjustable feet based on the standard installation height +40 mm / -8 mm (compared to +35 mm / -13 mm within Vario cooling 400 series)

To guarantee the aesthetics of the installation 10 mm wide side trims (RVA 460 910) should be installed on both sides of the appliance to cover the gap between the side walls of the appliance and the adjacent cabinetry.

If a Vario cooling 400 appliance was installed in the niche before, the screwing holes in the crown and side walls (if side trims were used) will become visible, upon removal of the appliance. To ensure perfect aesthetics of the newly installed RVY 497 the screwing holes should be covered.

Existing custom door panels can be re-used as well as the special accessory door panels from the Vario Cooling 400 series. New door panels need to have the widths displayed in the following drawing.

Be aware that any door panel to fully cover the niche will now protrude from the doors of the RVY 497 due to the difference in width.

This has an influence on the hinge movement and resulting clearances to adjacent cabinetry and handles.

Replacement of RVY 497 into 914 mm niche

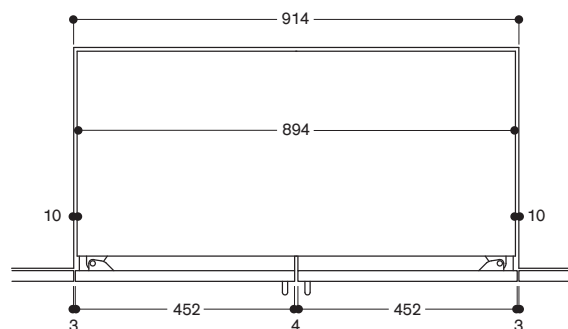

The resulting lateral gaps of 10 mm can be covered with side trims included in the installation accessory RVA 460 910

Measurements in mm

Replacement of side-by-side installation incl. RVY 497

In case of a side-by-side installation into an existing, unmodified niche previously designed for two 908 mm wide appliances or one 908 mm wide appliance and any narrower one, the installation accessory RVA 460 900 is required. Different side and center trims to cover the gaps between both appliances and between the appliances' side walls and the adjacent cabinetry are included.

For the narrow 3 mm side trims the installation accessory RVA 423 141 needs to be ordered.

For a correct installation, every appliance must be centered within their niche. For this, the spacers on the appliances' side walls may need to be exchanged before moving the appliance into the niche.

Depending on the niche width (A) and the appliances' widths (B) + (C) the gaps (D) + (E) + (F) have different measurements. See drawing:

Replacement of side-by-side installation incl. RVY 497

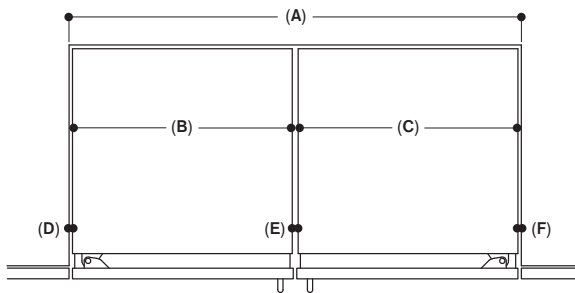

A: Niche width	1828	≤ 1676
B: Appliance 1 width	894	894
C: Appliance 2 width	894	≤ 756
D: Left gap	10	10
E: Center gap	20	13
F: Right gap	10	3

Measurements in mm

Replacement of side-by-side installation with Vario Cooling 400 series

If an RVY 497 must be installed side-by-side with a Vario cooling 400 appliance the installation accessory RVA 460 020 is required.

Beware that neither the overall appliance design nor the appliances' capabilities match and are not intended to do so.

All installation parts used in the initial Vario cooling 400 side-by-side installation need to be removed, including the heater kit. These are not necessary anymore. Depending on the individual installation situation, additional installation accessories may be necessary.

Side and center trims from the initial installation can be reused. Beware that the colours do not match, nor does the length of the trims fit perfectly, depending on the appliance used on. Side and center trims matching the new appliance's design to cover the gaps between both appliances and between the appliances' side walls and the adjacent cabinetry are included in the installation accessory RVA 460 020.

Important!
 To join the appliances outside of the niche and adjusting them to the niche height, the feet of the Vario cooling 400 appliance must be raised.
 This leads to:
 – A visible height difference in the plinth area between both appliances (when the doors are open)
 – The Vario Cooling 400 appliance not standing on its rollers, but on its front feet on the ground. To move it into the niche it must be slightly lifted with a hand truck.

Replacement of side-by-side installation with Vario Cooling 400 series

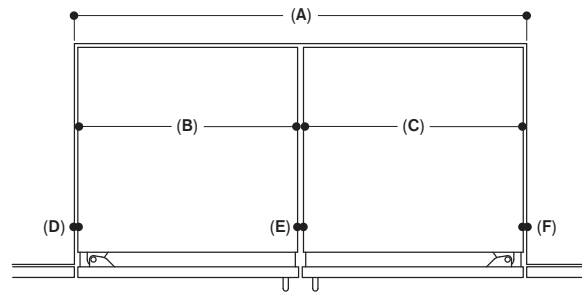

A: Niche width	1828	≤ 1676
B: Replacement appliances width	894	≤ 756
C: Vario Cooling 400 appliances width	≤ 908	≤ 908
D: Left gap	10	3
E: Center gap	13	6
F: Right gap	3	3

Measurements in mm



RB 492 305

With fresh cooling close to 0 °C
Fully integrated
Niche width 91.4 cm,
Niche height 213.4 cm
Cooling section with one door and one fully extendable freezing drawer

RB 472 305

With fresh cooling close to 0 °C
Fully integrated
Niche width 76.2 cm,
Niche height 213.4 cm
Cooling section with one door and one fully extendable freezing drawer



Included in the price

- 1 egg holder with lid
- 1 ice cube scoop

Installation accessories

RA 421 712

Stainless steel door panels with handles
For RB 472, panel thickness 19 mm.

RA 421 910

Stainless steel door panels with handles
For RB 492, panel thickness 19 mm.

RA 423 340

Side trims, 2 pieces, for RB.

RA 425 110

Handle bar, stainless steel, long
With 3 mounts, length 1131 mm,
height 49 mm, drilling distance
between each mount 554 mm.

RA 425 710

Handle bar, stainless steel, short
For RB 472, with 2 mounts,
length 658 mm, height 49 mm,
drilling distance between the mounts
637 mm.

RA 425 910

For RVY 497, RB 492 and RW 222,
with 2 mounts, length 810 mm, height
49 mm, drilling distance between the
mounts 787 mm.

RA 428 712

Stainless steel door panels, handleless
For RB 472, panel thickness 19 mm.

RA 428 910

Stainless steel door panels, handleless
For RB 492, panel thickness 19 mm.

RA 460 000

Accessory for side-by-side installation.
Not required if appliances are installed
more than 160 mm apart from each other.
Included in delivery for RF and RW.

Vario fridge-freezer combination 400 series

RB 492/RB 472

- Stainless steel interior with solid anthracite aluminium elements
- Warm white and glare-free LED light spots
- Opening assist for door with two options:
 1. Push-to-open function for integration into handleless furniture front
 2. Pull-to-open function to facilitate opening the door using a handle
- Flat stainless steel inner door, full-length
- Almost invisible rail system for shelves and door racks for flexible positioning
- Solid anthracite aluminium door racks
- 1 fresh cooling drawer close to 0 °C with manually adjustable temperature and 1 fresh cooling drawer with manually adjustable humidity
- Integrated ice maker with fixed inlet water connection
- Fully extendable freezer drawer with practical divider in anthracite
- TFT touch display
- Total volume 555/452 litres

Handling

TFT touch display operation.
Clear text display.

Technical features

Dynamic cold air distribution.
Automatic defrosting with defrost water evaporation.
Cushioned door closing system.
Activated charcoal air filter.
Rest mode certified by Star-K.
When rest mode is active, the appliance can only be opened using a handle.
Open-door and malfunction alarm.

Selected digital services (Home Connect)

Remote control and monitoring.
Remote diagnostics.

Please read additional information on Home Connect on page 411.

Cooling

No-Frost technology with fast cooling.
Temperature adjustable from +2 °C to +8 °C.
2 safety glass shelves, white glass, individually adjustable in height.
1 integrated shelf with satin-finished glass.
4 brilliant LED light spots with warm white, glare-free light (3500 K) within cooling area and drawers.
Flat door rail system with fully flexible positioning of door racks.
3 height adjustable door racks, 1 of which is extra deep.
Total volume all refrigerator compartments 389/316 litres.

Fresh cooling close to 0 °C

1 fully extendable fresh cooling drawer close to 0 °C with transparent front, illuminated.
Cushioned closing system.
Temperature can be adjusted manually.
Ideal for meat, fish and poultry.

RA 460 013

Additional side heating element 230 V.
Required if appliances are installed with a distance greater than 16 mm and less than 160 mm next to each other and for all built-in situations in a very humid environment. Not required if appliances are installed more than 160 mm apart from each other.

RA 460 030

Connecting element for vertically split fronts (for fridge-freezer combination).

RA 464 713

Ventilation grille stainless steel
For RB 472.

RA 464 913

Ventilation grille stainless steel
For RB 492.

Special accessories

RA 430 100

Storage container with transparent lid, anthracite.

RA 450 012

Activated charcoal water filter
For RVY, RY, RB and RF.

Fresh cooling

1 fully extendable fresh cooling drawer with transparent front, illuminated.
Cushioned closing system.
Humidity can be adjusted manually.
Ideal for fruit and vegetables.

Freezing

No-Frost technology with fast freezing at -30 °C.
Temperature adjustable from -24 °C to -14 °C.
4-star freezer compartment.
Freezing capacity 14/14 kg/24 h.
Storage time after a malfunction 13/13 h.
2 fully extendable drawers, one of them inside. Outer drawer with synchronously running pull-out rails.
Interior lighting with 2 LED light spots, warm white light.
Volume 166/136 litres.

Ice maker

Integrated in the freezer compartment, with fixed inlet water connection.
Particle filter for water inlet, integrated in ventilation grille area.
Saturation indicator shown in TFT touch display.
Can be switched off.
Ice cube production approx. 1.6/1.7 kg/24 h.
Removable ice storage container with approx. 3 kg capacity.

Consumption data

Energy efficiency class E at a range of energy efficiency classes from A to G.
Energy consumption 326/295 kWh/year.
Noise level 42 dB (A) re 1 pW.

Planning notes

Flat hinge.
Door hinge right, reversible.
Door opening angle of 115°, fixable at 90°.
Max. door panel weight:
Door 47/41 kg.
Drawer 12/10 kg.
Shut-off valve for water connection must be planned next to the appliance and always be accessible.
If the water pressure exceeds 0.8 MPa (8 bar), connect pressure relief valve between water tap and hose set.

Please read additional planning notes on page 328 – 335.

Connection

Total connected load 0.300 kW.
Connecting cable 3.0 m, pluggable.
Water inlet.
Supply hose 2.0 m with 3/4" connection.
Water pressure 2 to 8 bar.

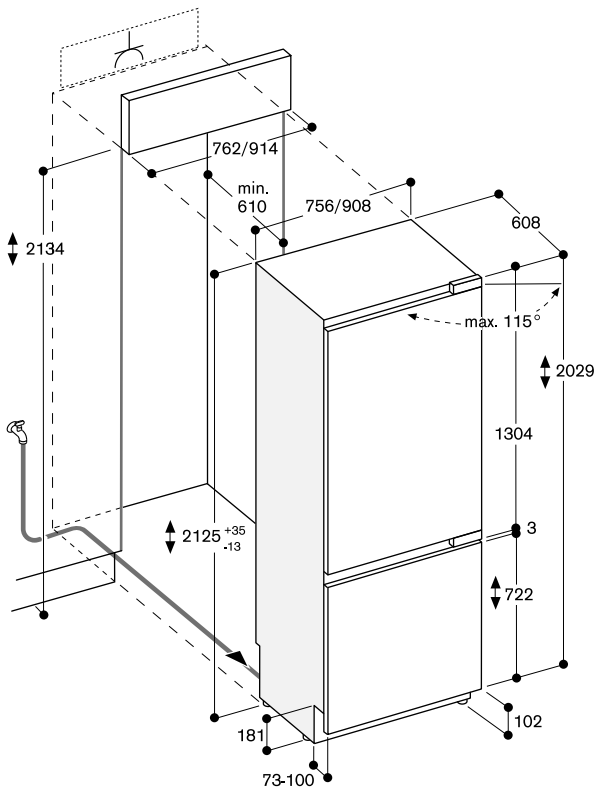

The maximum door panel dimensions are based on a clearance of 3 mm.



RC 492 305

With fresh cooling 0 °C
Fully integrated
Niche width 91.4 cm,
Niche height 213.4 cm

RC 472 305

With fresh cooling 0 °C
Fully integrated
Niche width 76.2 cm,
Niche height 213.4 cm

RC 462 305

With fresh cooling 0 °C
Fully integrated
Niche width 61 cm,
Niche height 213.4 cm



Included in the price

1 egg holder with lid

Installation accessories

RA 421 610

Stainless steel door panel with handle
For 61 cm wide appliances, panel
thickness 19 mm.

RA 421 710

Stainless steel door panel with handle
For 76.2 cm wide appliances, panel
thickness 19 mm.

RA 421 911

Stainless steel door panel with handle
For 91.4 cm wide appliances, panel
thickness 19 mm.

RA 423 140

Side trims, long.

RA 425 110

Handle bar, stainless steel, long
With 3 mounts, length 1131 mm,
height 49 mm, drilling distance
between each mount 554 mm.

RA 428 610

Stainless steel door panel, handleless
For 61 cm wide appliances, panel
thickness 19 mm.

RA 428 710

Stainless steel door panel, handleless
For 76.2 cm wide appliances, panel
thickness 19 mm.

RA 428 911

Stainless steel door panel, handleless
For 91.4 cm wide appliances, panel
thickness 19 mm.

RA 460 000

Accessory for side-by-side installation.
Not required if appliances are installed
more than 160 mm apart from each other.
Included in delivery for RF and RW.

Vario refrigerator 400 series

RC 492/RC 472/RC 462

- Stainless steel interior with solid anthracite aluminium elements
- Warm white and glare-free LED light spots
- Opening assist for door with two options:
 1. Push-to-open function for integration into handleless furniture front
 2. Pull-to-open function to facilitate opening the door using a handle
- The drawers in the RC and RF models are positioned at the same height. With side-by-side installation, the glass shelves and door racks can be aligned on the same level
- Flat stainless steel inner door, full-length
- Almost invisible rail system for shelves and door racks for flexible positioning
- Solid anthracite aluminium door racks
- 1 fresh cooling drawer 0 °C with temperature control from -1 °C to +3 °C and 1 fresh cooling drawer with manually adjustable humidity
- TFT touch display
- Total volume 579/467/357 litres

Handling

TFT touch display operation.
Clear text display.

Technical features

Dynamic cold air distribution.
Automatic defrosting with defrost water evaporation.
Cushioned door closing system.
Activated charcoal air filter.
Rest mode certified by Star-K.
When rest mode is active, the appliance can only be opened using a handle.
Open-door and malfunction alarm.

Selected digital services (Home Connect)

Remote control and monitoring.
Remote diagnostics.

Please read additional information on Home Connect on page 411.

Cooling

Fast cooling.
Temperature adjustable from +2 °C to +8 °C.
3 safety glass shelves, white glass, individually adjustable in height.
1 shallow, fully extendable drawer with transparent front.
1 integrated shelf with satin-finished glass.
Cushioned closing system.
4 brilliant LED light spots with warm white, glare-free light (3500 K) within cooling area and drawers.
Flat door rail system with fully flexible positioning of door racks.
3 height adjustable door racks, 1 of which is extra deep.
Volume 494/398/305 litres.

RA 460 013

Additional side heating element 230 V.
Required if appliances are installed with a distance greater than 16 mm and less than 160 mm next to each other and for all built-in situations in a very humid environment. Not required if appliances are installed more than 160 mm apart from each other.

RA 460 020

Connecting element for vertically split appliance fronts (for a flush front).

RA 464 611

Ventilation grille stainless steel
For 61 cm wide appliances.

RA 464 711

Ventilation grille stainless steel
For 76.2 cm wide appliances.

RA 464 911

Ventilation grille stainless steel
For 91.4 cm wide appliances.

Special accessories

RA 430 100

Storage container with transparent lid, anthracite.

Fresh cooling 0 °C

1 large, fully extendable fresh cooling 0 °C drawer with transparent front, illuminated.
Cushioned closing system.
Temperature control via central TFT display, temperature can be adjusted from -1 °C to +3 °C.
Ideal for meat, fish and poultry.
Volume 85/69/52 litres.

Fresh cooling

1 fully extendable fresh cooling drawer with transparent front, illuminated.
Cushioned closing system.
Humidity can be adjusted manually.
Ideal for fruit and vegetables.

Consumption data

Energy efficiency class E at a range of energy efficiency classes from A to G.
Energy consumption
182/166/150 kWh/year.
Noise level 40 dB (A) re 1 pW.

Planning notes

Flat hinge.
Door hinge right, reversible.
Door opening angle of 115°, fixable at 90°.
Max. door panel weight 43/29/41 kg.

Please read additional planning notes on page 328 – 335.

Connection

Total connected load 0.300 kW.
Connecting cable 3.0 m, pluggable.

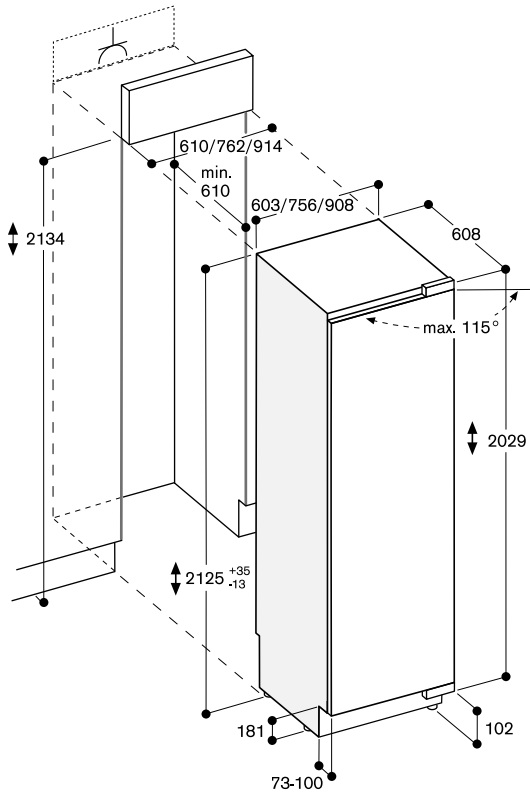

The maximum door panel dimensions are based on a clearance of 3 mm.



RF 471 306

Fully integrated, with ice maker
Niche width 76.2 cm,
Niche height 213.4 cm

RF 461 306

Fully integrated, with ice maker
Niche width 61 cm,
Niche height 213.4 cm

RF 411 306

Fully integrated, with ice maker
Niche width 45.7 cm,
Niche height 213.4 cm



Included in the price

- 1 ice cube scoop
- 1 Accessory for side-by-side installation
- 1 Ice storage container, small
- 1 Ice storage container, large

Installation accessories

RA 421 110

Stainless steel door panel with handle
For 45.7 cm wide appliances, panel thickness 19 mm.

RA 421 610

Stainless steel door panel with handle
For 61 cm wide appliances, panel thickness 19 mm.

RA 421 710

Stainless steel door panel with handle
For 76.2 cm wide appliances, panel thickness 19 mm.

RA 423 140

Side trims, long.

RA 425 110

Handle bar, stainless steel, long
With 3 mounts, length 1131 mm,
height 49 mm, drilling distance
between each mount 554 mm.

RA 428 110

Stainless steel door panel, handleless
For 45.7 cm wide appliances, panel
thickness 19 mm.

RA 428 610

Stainless steel door panel, handleless
For 61 cm wide appliances, panel
thickness 19 mm.

RA 428 710

Stainless steel door panel, handleless
For 76.2 cm wide appliances, panel
thickness 19 mm.

Vario freezer 400 series

RF 471/RF 461/RF 411

- Stainless steel interior with solid anthracite aluminium elements
- Warm white and glare-free LED light spots
- Opening assist for door with two options:
 1. Push-to-open function for integration into handleless furniture front
 2. Pull-to-open function to facilitate opening the door using a handle
- The drawers in the RC and RF models are positioned at the same height. With side-by-side installation, the glass shelves and door racks can be aligned on the same level
- Material and aesthetics of interior as for RC model
 - Glass shelves
 - Solid anthracite aluminium door racks
- Flat stainless steel inner door, full-length
- Almost invisible rail system for shelves and door racks for flexible positioning
- Integrated ice maker with fixed inlet water connection
- TFT touch display
- Total volume 445/344/240 litres

Handling

TFT touch display operation.
Clear text display.

Technical features

Dynamic cold air distribution.
Automatic defrosting with defrost water evaporation.
Cushioned door closing system.
Rest mode certified by Star-K.
When rest mode is active, the appliance can only be opened using a handle.
Open-door and malfunction alarm.

Selected digital services (Home Connect)

Remote control and monitoring.
Remote diagnostics.

Please read additional information on Home Connect on page 411.

Freezing

No-Frost technology with fast freezing at -30 °C.
Temperature adjustable from -24 °C to -14 °C.
4-star freezer compartment.
Freezing capacity 23/19/16 kg/24 h.
Storage time after a malfunction 10/7/6 h.
4 safety glass shelves, white glass, 3 of which are individually height adjustable.
2 fully extendable drawers with transparent front.
Brilliant LED light spots with warm white, glare-free light (3500 K).
Flat door rail system with fully flexible positioning of door racks.
4 height-adjustable door racks.

RA 460 013

Additional side heating element 230 V.
Required if appliances are installed with a distance greater than 16 mm and less than 160 mm next to each other and for all built-in situations in a very humid environment. Not required if appliances are installed more than 160 mm apart from each other.

RA 460 020

Connecting element for vertically split appliance fronts (for a flush front).

RA 464 113

Ventilation grille stainless steel
For 45.7 cm wide appliances with integrated water filter.

RA 464 616

Ventilation grille stainless steel
For 61 cm wide appliances with integrated water filter.

RA 464 714

Ventilation grille stainless steel
For 76.2 cm wide appliances with integrated water filter.

Special accessories

RA 450 012

Activated charcoal water filter
For RY, RY, RB and RF.

Ice maker

Integrated in the freezer compartment, with fixed inlet water connection.
Particle filter for water inlet, integrated in ventilation grille area.
Saturation indicator shown in TFT touch display.
Can be switched off.
Ice cube production approx. 1.7/1.5/1.4 kg/24 h.
Removable ice storage container with approx. 4 kg capacity.

Consumption data

Energy efficiency class E at a range of energy efficiency classes from A to G.
Energy consumption 321/284/246 kWh/year.
Noise level 42 dB (A) re 1 pW.

Planning notes

Flat hinge.
Door hinge left, reversible.
Door opening angle of 115°, fixable at 90°.
In case of door opening angle of 90°, the drawers have restricted access and the standard ice storage container cannot be removed.
A small ice storage container (RA 448 220) is available to ensure access. This change must be done prior to fixing the door.
Max. door panel weight 29/41/59 kg.
Shut-off valve for water connection must be planned next to the appliance and always be accessible.
If the water pressure exceeds 0.8 MPa (8 bar), connect pressure relief valve between water tap and hose set.

Please read additional planning notes on page 328 – 335.

Connection

Total connected load 0.300 kW.
Connecting cable 3.0 m, pluggable.
Water inlet.
Supply hose 2.0 m with 3/4 " connection.
Water pressure 2 to 8 bar.

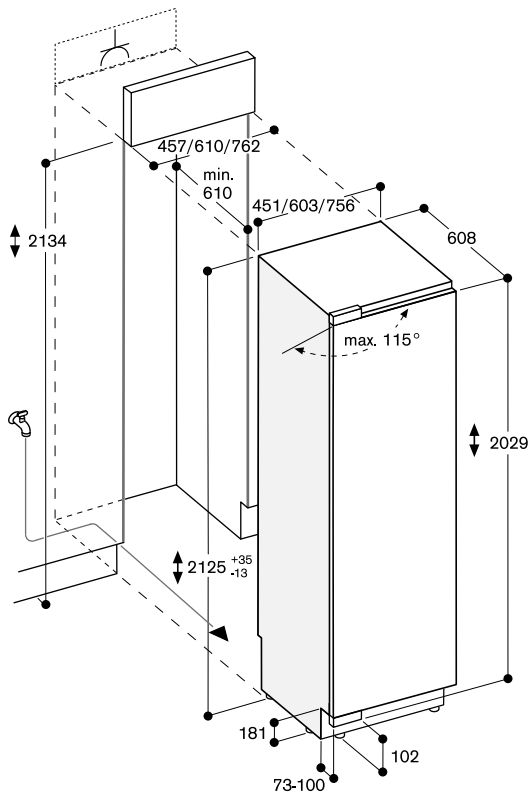

The maximum door panel dimensions are based on a clearance of 3 mm.



RF 410 304

Fully integrated
Niche width 45.7 cm,
Niche height 213.4 cm



Included in the price

1 Accessory for side-by-side installation

Installation accessories

RA 421 110

Stainless steel door panel with handle
For 45.7 cm wide appliances, panel thickness 19 mm.

RA 423 140

Side trims, long.

RA 425 110

Handle bar, stainless steel, long
With 3 mounts, length 1131 mm,
height 49 mm, drilling distance
between each mount 554 mm.

RA 428 110

Stainless steel door panel, handleless
For 45.7 cm wide appliances, panel
thickness 19 mm.

RA 460 013

Additional side heating element 230 V.
Required if appliances are installed
with a distance greater than 16 mm and
less than 160 mm next to each other
and for all built-in situations in a very
humid environment. Not required if
appliances are installed more than
160 mm apart from each other.

RA 460 020

Connecting element for vertically split
appliance fronts (for a flush front).

RA 464 111

Ventilation grille stainless steel
For 45.7 cm wide appliances.

Vario freezer 400 series

RF 410

- Stainless steel interior with solid anthracite aluminium elements
- Warm white and glare-free LED light spots
- Opening assist for door with two options:
 1. Push-to-open function for integration into handleless furniture front
 2. Pull-to-open function to facilitate opening the door using a handle
- The drawers in the RC and RF models are positioned at the same height. With side-by-side installation, the glass shelves and door racks can be aligned on the same level
- Material and aesthetics of interior as for RC model
 - Glass shelves
 - Solid anthracite aluminium door racks
- Flat stainless steel inner door, full-length
- Almost invisible rail system for shelves and door racks for flexible positioning
- TFT touch display
- Total volume 240 litres

Handling

TFT touch display operation.
Clear text display.

Technical features

Dynamic cold air distribution.
Automatic defrosting with defrost water evaporation.
Cushioned door closing system.
Rest mode certified by Star-K.
When rest mode is active, the appliance can only be opened using a handle.
Open-door and malfunction alarm.

Selected digital services (Home Connect)

Remote control and monitoring.
Remote diagnostics.

Please read additional information on Home Connect on page 411.

Freezing

No-Frost technology with fast freezing at -30 °C.
Temperature adjustable from -24 °C to -14 °C.
4-star freezer compartment.
Freezing capacity 16 kg/24 h.
Storage time after a malfunction 6 h.
4 safety glass shelves, white glass, 4 of which are individually height adjustable.
2 fully extendable drawers with transparent front.
Brilliant LED light spots with warm white, glare-free light (3500 K).
Flat door rail system with fully flexible positioning of door racks.
4 height-adjustable door racks.

Consumption data

Energy efficiency class E at a range of energy efficiency classes from A to G.
Energy consumption 246 kWh/year.
Noise level 42 dB (A) re 1 pW.

Planning notes

Flat hinge.
Door hinge left, reversible.
Door opening angle of 115°, fixable at 90°.
For an installation with a door opening angle of 90°, the drawers have a restricted access.
Max. door panel weight 59 kg.

Please read additional planning notes on page 328 – 335.

Connection

Total connected load 0.300 kW.
Connecting cable 3.0 m, pluggable.

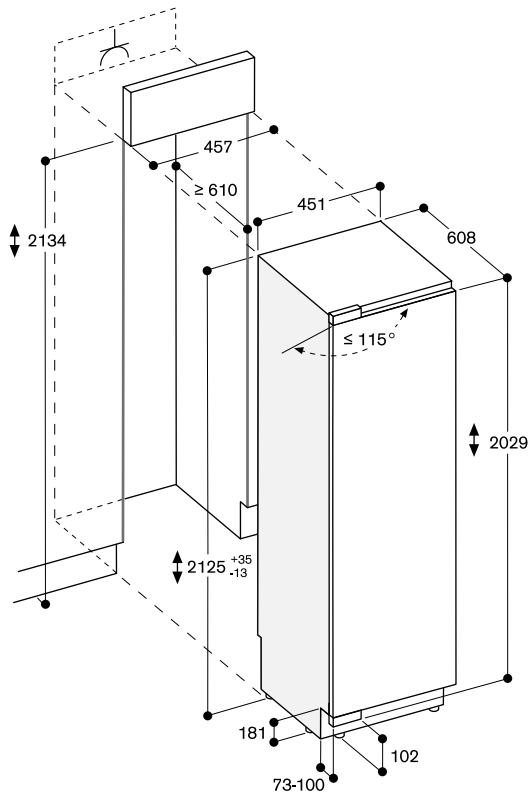

The maximum door panel dimensions are based on a clearance of 3 mm.
measurements in mm



RW 466 365

Fully integrated, with glass door
Niche width 61 cm,
Niche height 213.4 cm



RW 466 305

Fully integrated, with solid door
Niche width 61 cm,
Niche height 213.4 cm



Included in the price

1 Accessory for side-by-side
installation

Installation accessories

RA 420 010

Door lock for RW 414,
RW 464 and RW 466.

RA 421 610

Stainless steel door panel with handle
For 61 cm wide appliances, panel
thickness 19 mm.

RA 421 611

Stainless steel door panel frame with
handle
For 61 cm wide appliances, left-hinged,
panel thickness 19 mm.

RA 421 612

Stainless steel door panel frame with
handle
For 61 cm wide appliances,
right-hinged, panel thickness 19 mm.

RA 423 140

Side trims, long.

RA 425 110

Handle bar, stainless steel, long
With 3 mounts, length 1131 mm,
height 49 mm, drilling distance
between each mount 554 mm.

RA 428 610

Stainless steel door panel, handleless
For 61 cm wide appliances, panel
thickness 19 mm.

RA 428 611

Stainless steel door panel frame,
handleless
For 61 cm wide appliances, panel
thickness 19 mm.

Vario wine climate cabinet 400 series

RW 466

- 3 independently controllable climate zones
- Consistent temperatures with exact control from +5 °C to +20 °C
- Humidity control
- Stainless steel interior
- Fully extendable bottle trays in oak wood and solid aluminium in anthracite
- Bottle trays with hidden telescopic rails
- Warm white and glare-free LED light spots
- 5 preset lighting scenarios, selectable via TFT display
- Opening assist for door with two options:
 1. Push-to-open function for integration into handleless furniture front
 2. Pull-to-open function to facilitate opening the door using a handle
- Low-vibration operation
- TFT touch display
- Number of standard wine bottles: 99

Handling

TFT touch display operation.
Clear text display.
Lockable door (with door lock
RA 420 010).

Technical features

Dynamic cold air distribution.
Automatic defrosting with defrost water evaporation.
Cushioned door closing system.
Activated charcoal air filter.
UV-protection.
Rest mode certified by Star-K.
When rest mode is active, the appliance can only be opened using a handle.
Open-door and malfunction alarm.

Selected digital services (Home Connect)

Remote control and monitoring.
Remote diagnostics.
Light scenarios.

Please read additional information on Home Connect on page 411.

Features

Capacity 99 bottles
(based on 0.75 l standard bottles).
12 bottle trays,
- 9 fully extendable trays
- 3 suitable for storage of Magnum bottles.
Flexible interior configuration possible by adding or removing fully extendable bottle trays.
Storage of up to 12 Magnum bottles with standard tray configuration (12 bottle trays).
Space for max. 12 bottle trays.
2 brilliant LED light spots with warm white, glare-free light (3500 K) in each climate zone.
5 different lighting scenarios can be selected for individual wine presentation.
Total volume 370 litres.

RA 460 013

Additional side heating element 230 V.
Required if appliances are installed with a distance greater than 16 mm and less than 160 mm next to each other and for all built-in situations in a very humid environment. Not required if appliances are installed more than 160 mm apart from each other.

RA 460 020

Connecting element for vertically split appliance fronts (for a flush front).

RA 464 611

Ventilation grille stainless steel
For 61 cm wide appliances.

Special accessories

RA 430 000

Screw hole cover set. 8 pieces.

RA 491 661

Fully extendable bottle trays with hidden telescopic rails in oak wood and solid aluminium in anthracite
For 61 cm wide appliances.

RA 492 660

Removable shelf with oak wood frame
Suitable for decanters and open bottles.
For 61 cm wide appliances.

RA 493 060

Presenter in oak wood and aluminium in anthracite for single bottle display
1 piece.

RA 498 640

Bottle support in oak wood for convenient storage of bottles on the division plate.
For 61 cm wide appliances.

Consumption data

Energy efficiency class G/F at a range of energy efficiency classes from A to G.
Energy consumption 155/129 kWh/year.
Noise level 42 dB (A) re 1 pW.

Planning notes

Flat hinge.
Door hinge right, reversible.
Door opening angle of 115°, fixable at 90°.
Max. door panel weight 73 kg.
The mains socket needs to be planned outside the built-in niche.
No transport/operation above 2000 m sea level.

Please read additional planning notes on page 328 – 335.

Connection

Total connected load 0.300 kW.
Connecting cable 3.0 m, pluggable.

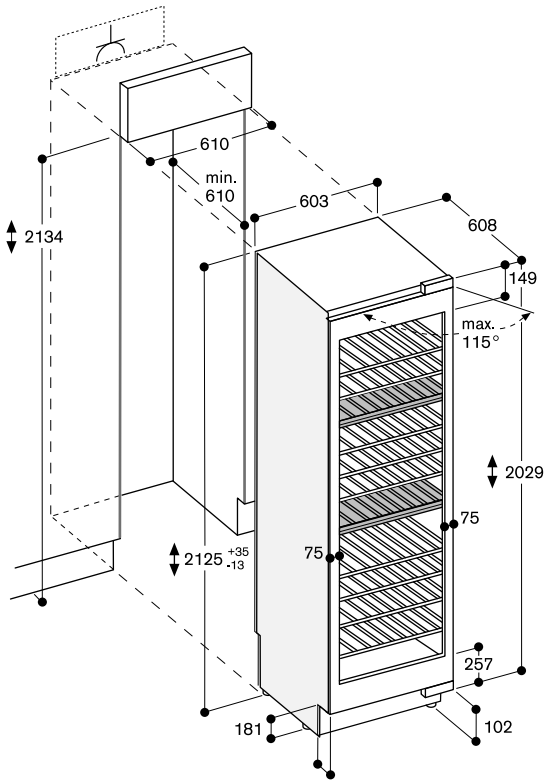

The maximum door panel dimensions are based on a clearance of 3 mm.

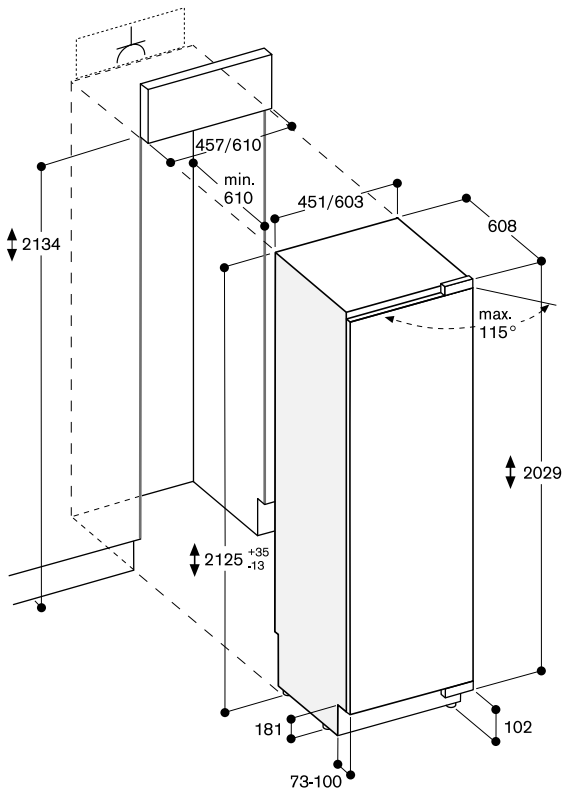

The maximum door panel dimensions are based on a clearance of 3 mm.

Bottle storage

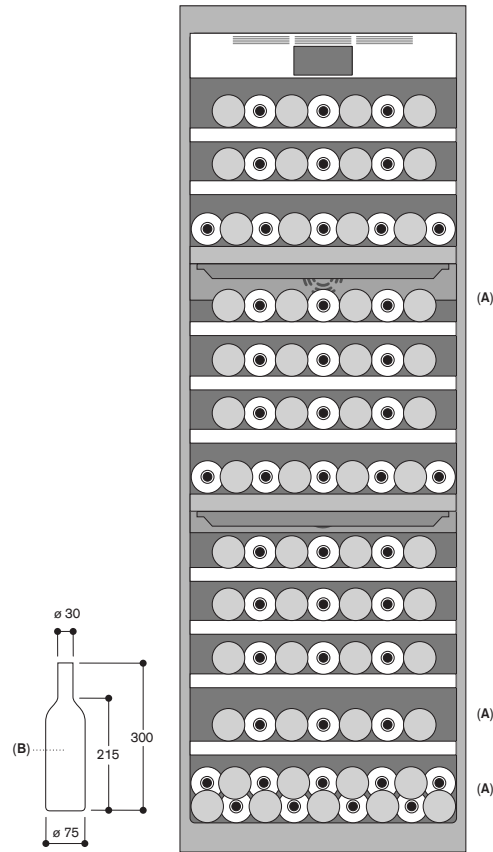

- A: Suitable area for storage of magnum bottles in standard tray configuration
- B: 0.75 litres

Measurements in mm



RW 414 365

Fully integrated, with glass door
Niche width 45.7 cm,
Niche height 213.4 cm



RW 414 305

Fully integrated, with solid door
Niche width 45.7 cm,
Niche height 213.4 cm



Included in the price

1 Accessory for side-by-side installation

Installation accessories

RA 420 010

Door lock for RW 414,
RW 464 and RW 466.

RA 421 110

Stainless steel door panel with handle
For 45.7 cm wide appliances, panel thickness 19 mm.

RA 421 111

Stainless steel door panel frame with handle
For 45.7 cm wide appliances,
left-hinged, panel thickness 19 mm.

RA 421 112

Stainless steel door panel frame with handle
For 45.7 cm wide appliances,
right-hinged, panel thickness 19 mm.

RA 423 140

Side trims, long.

RA 425 110

Handle bar, stainless steel, long
With 3 mounts, length 1131 mm,
height 49 mm, drilling distance
between each mount 554 mm.

RA 428 110

Stainless steel door panel, handleless
For 45.7 cm wide appliances, panel thickness 19 mm.

RA 428 111

Stainless steel door panel frame,
handleless
For 45.7 cm wide appliances, panel thickness 19 mm.

Vario wine climate cabinet 400 series RW 414

- 2 independently controllable climate zones
- Consistent temperatures with exact control from +5 °C to +20 °C
- Humidity control
- Stainless steel interior
- Fully extendable bottle trays in oak wood and solid aluminium in anthracite
- Bottle trays with hidden telescopic rails
- Warm white and glare-free LED light spots
- 5 preset lighting scenarios, selectable via TFT display
- Opening assist for door with two options:
 1. Push-to-open function for integration into handleless furniture front
 2. Pull-to-open function to facilitate opening the door using a handle
- Low-vibration operation
- TFT touch display
- Number of standard wine bottles: 70

Handling

TFT touch display operation.
Clear text display.
Lockable door (with door lock RA 420 010).

Technical features

Dynamic cold air distribution.
Automatic defrosting with defrost water evaporation.
Cushioned door closing system.
Activated charcoal air filter.
UV-protection.
Rest mode certified by Star-K.
When rest mode is active, the appliance can only be opened using a handle.
Open-door and malfunction alarm.

Selected digital services (Home Connect)

Remote control and monitoring.
Remote diagnostics.
Light scenarios.

Please read additional information on Home Connect on page 411.

Features

Capacity 70 bottles (based on 0.75 l standard bottles).
12 bottle trays,
- 10 fully extendable trays
- 3 suitable for storage of Magnum bottles.
Flexible interior configuration possible by adding or removing fully extendable bottle trays.
Storage of up to 6 Magnum bottles with standard tray configuration (12 bottle trays).
Space for max. 13 bottle trays.
2 brilliant LED light spots with warm white, glare-free light (3500 K) in each climate zone.
5 different lighting scenarios can be selected for individual wine presentation.
Total volume 272 litres.

RA 460 013

Additional side heating element 230 V.
Required if appliances are installed with a distance greater than 16 mm and less than 160 mm next to each other and for all built-in situations in a very humid environment. Not required if appliances are installed more than 160 mm apart from each other.

RA 460 020

Connecting element for vertically split appliance fronts (for a flush front).

RA 464 111

Ventilation grille stainless steel
For 45.7 cm wide appliances.

Special accessories

RA 430 000

Screw hole cover set. 8 pieces.

RA 491 161

Fully extendable bottle trays with hidden telescopic rails in oak wood and solid aluminium in anthracite
For 45.7 cm wide appliances.

RA 492 160

Removable shelf with oak wood frame
Suitable for decanters and open bottles.

For 45.7 cm wide appliances.

RA 493 060

Presenter in oak wood and aluminium in anthracite for single bottle display
1 piece.

RA 498 140

Bottle support in oak wood for convenient storage of bottles on the division plate.

For 45.7 cm wide appliances.

Consumption data

Energy efficiency class G/F at a range of energy efficiency classes from A to G.
Energy consumption 145/120 kWh/year.
Noise level 42 dB (A) re 1 pW.

Planning notes

Flat hinge.
Door hinge right, reversible.
Door opening angle of 115°, fixable at 90°.
Max. door panel weight 76 kg.
The mains socket needs to be planned outside the built-in niche.
No transport/operation above 2000 m sea level.

Please read additional planning notes on page 328 – 335.

Connection

Total connected load 0.300 kW.
Connecting cable 3.0 m, pluggable.

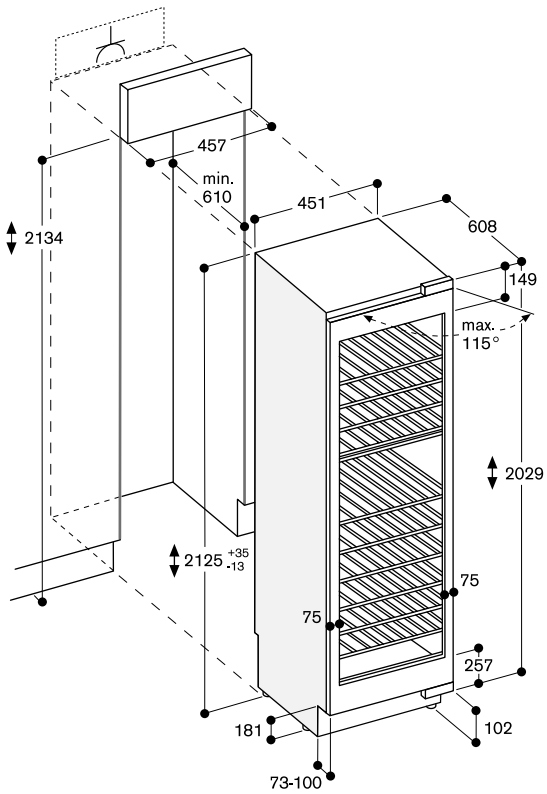

The maximum door panel dimensions are based on a clearance of 3 mm.

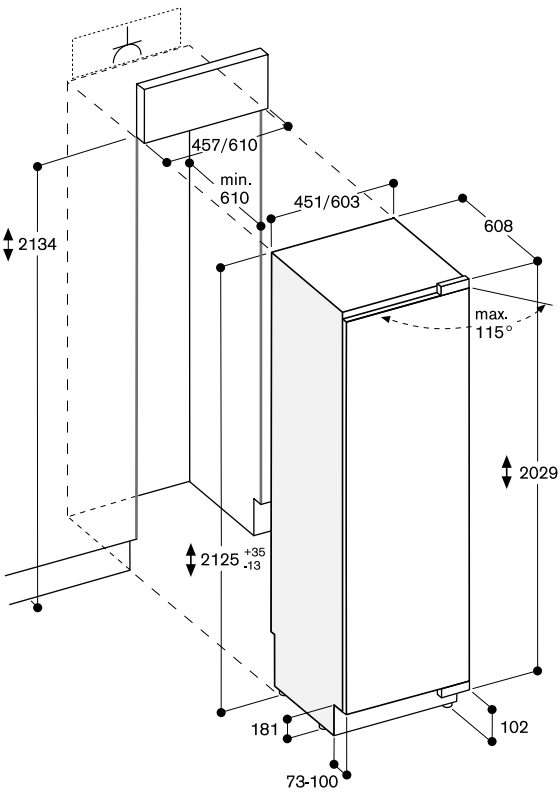

The maximum door panel dimensions are based on a clearance of 3 mm.

Bottle storage

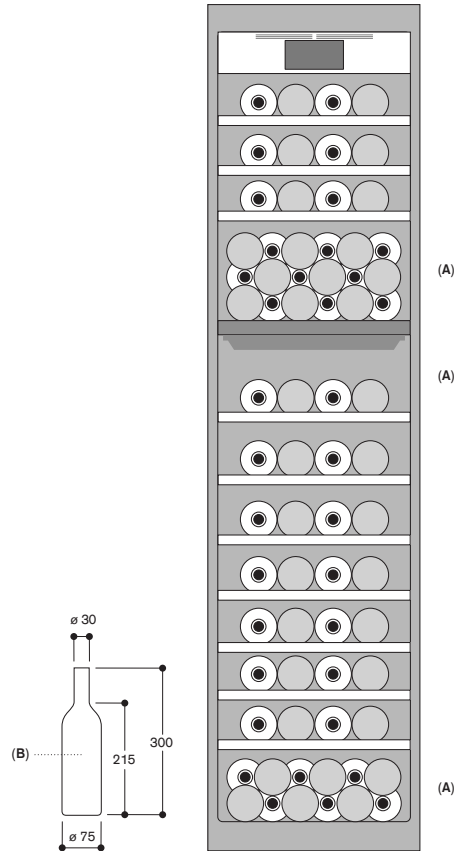

A: Suitable area for storage of magnum bottles in standard tray configuration
 B: 0.75 litres

Measurements in mm

Additional planning notes for Vario cooling 400 series

The side walls of the adjacent cabinetry have to be dimensionally stable, as the Vario cooling appliances are secured in the niche with only an anti-tilt bracket on the top back and on the bottom at the side.

Vario cooling appliances can be installed handle to handle as a side-by-side combination. In this case the side-by-side installation kit RA 460 000 is required. If the distance between the appliances is greater than 16 mm or less than 160 mm or the environment very humid the additional side heating element RA 460 013 needs to be installed between the appliances to avoid condensation.

If the appliances are combined hinge to handle in a very humid environment the additional side heating element RA 460 013 is required as well. It can be omitted if the distance between the appliances is greater than 160 mm. The additional side heating element RA 460 013 does not take up any additional space. It is already included in the niche dimensions.

If the Vario cooling appliances are joined together hinge to hinge an additional stable side wall must be foreseen.

If restrictions in use are accepted (no simultaneous opening of the doors possible) the appliances can be joined together directly, using the side-by-side installation accessory RA 460 000.

When installing a Vario cooling appliance from the 400 series handleless next to a BO/BM/BS/CM from the oven 400 series, a minimum lateral distance of 30 mm is required, if the door of the Vario cooling appliance opens towards the BO/BM/BS/CM. When installing a Vario cooling appliance from the 400 series next to a BO/BM/BS from the ovens 400 series, a lateral distance of 60 mm is required, if the BO/BM/BS retrofitted handle is on the same side as the Vario cooling appliance door hinge. For the same installation next to a BOP/BMP/BSP from the ovens 200 series, a distance of 40 mm is required.

Door opening angle

To ensure correct kitchen planning it is essential to take into account the opening angle of the appliance door (plus fitted cabinet door and handle). There should be no possibility of collision with other kitchen furnishings (worktops, handles of other cabinetry etc.) or parts of the room (walls, protrusions etc.).

The space needed for the hinge and the consequential distance to the adjacent cabinetry and its handle can, depending on the panel thickness, be seen in the following drawing. The drawing assumes a panel thickness of 19 mm.

If a collision occurs, the following options are available to remedy the situation: Restrict the door opening angle to 90° (standard 115°). Pin to restrict the angle is enclosed with the appliance. Due to limitation in use, it is not recommended to install a freezer (RF 411, RF 461, RF 471) next to a wall which requires a door angle of 90° or any other installation which requires a 90° door angle as drawers can't be pulled out completely or removed. If the restrictions in use are accepted, the ice storage container must be exchanged for the small ice storage container (RA 448 220). This must be done prior fixing the door.

Fit a spacer between the appliance and the cabinetry that it would collide with. Rearrange surrounding cabinetry or appliance.

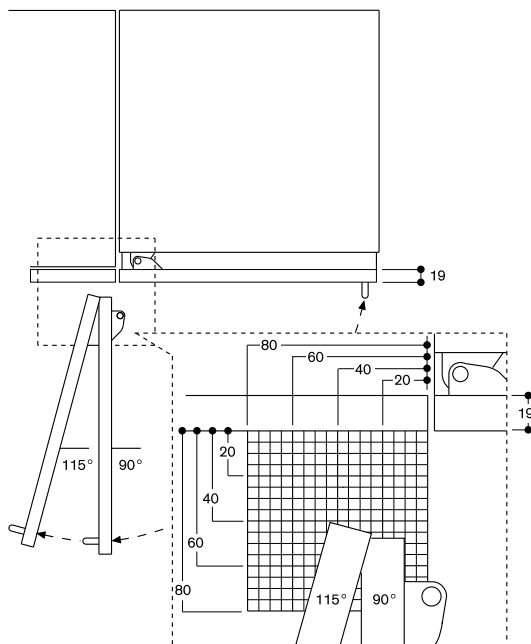

The hinge travel and resulting clearances from adjacent furniture units and handles can be found from the drawing while allowing for the thickness of the front panel. In the drawing, a furniture unit front panel thickness of 19 mm was assumed.

Wall clearance RB 492

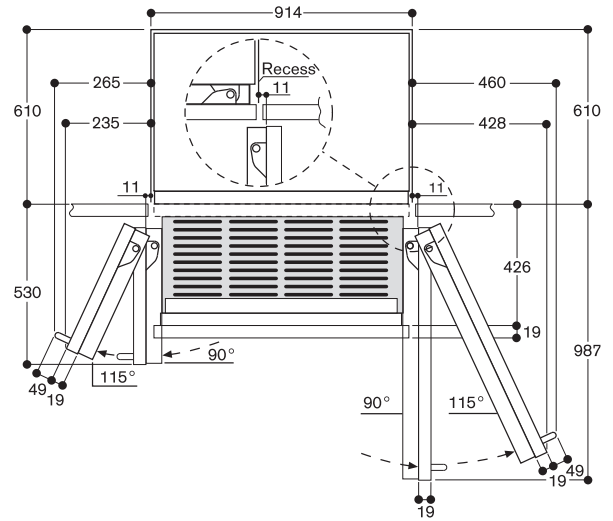

In the drawing, a unit front thickness of 19 mm and a Gaggenau unit handle of 49 mm were taken as a basis.

Wall clearance RB 472/RC/RF/RW

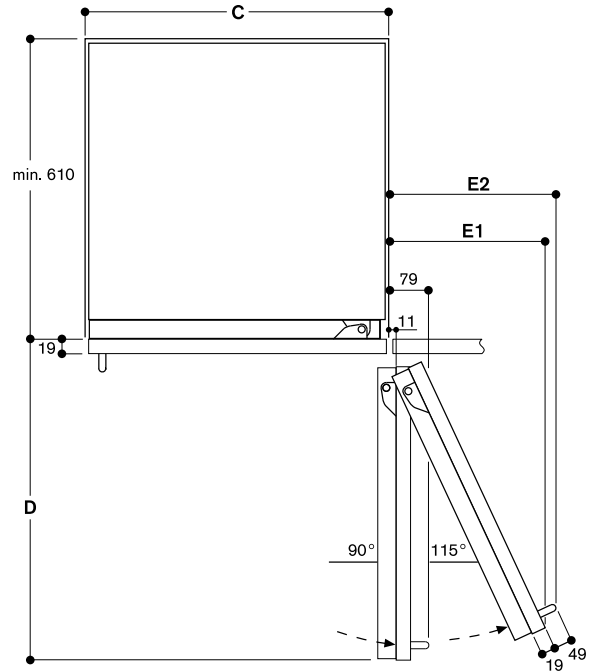

Recess width C	D	E1	E2
457 mm	525 mm	235 mm	265 mm
610 mm	677 mm	299 mm	330 mm
762 mm	830 mm	364 mm	395 mm
914 mm	980 mm	428 mm	460 mm

In the drawing, a unit front thickness of 19 mm and a Gaggenau unit handle of 49 mm were taken as a basis.

Notes:

- The adjustable feet have an adjustment range of +35 mm to -13 mm. The standard height displayed in the pictures is 0 mm.
- For proper ventilation of the appliance, the clearance between the floor and bottom edge of the cabinet front must be at least 100 mm.
- The panel thickness of customised doors can range from between 19 mm and 38 mm (in the picture 19 mm).

Unlike conventional built-in appliances, Vario cooling appliances stand on the floor. This means that the installation niche is a space in a line of kitchen units.

Installation niche

The specified dimensions of the installation niche must be observed to guarantee the proper installation of the appliance and the design of the cabinet front. It is particularly important that the installation niche is square. The side walls must be smooth, not have any protrusions or unevenness. Use the appropriate tools, e.g. spirit level, diagonal measurements, etc. to determine whether the installation niche is square. The side walls and the crown of the installation niche must be at least 16 mm thick.

Installation niche for an individual appliance:

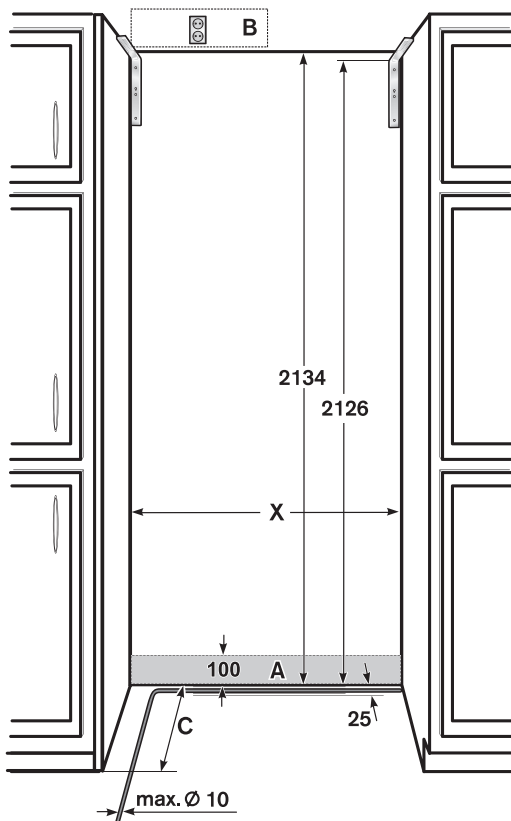

- A Area for installation the water connection
- B Area for installation the electrical connection must be outside the niche
- C Depth of installation niche, depending on kitchen design.
C = 610 mm minimum!
- X Width of installation niche, refer to the table below for more details:

Appliance type	Width of the niche X
451 mm	457 mm
603 mm	610 mm
756 mm	762 mm
908 mm	914 mm

Installation niche for a side-by-side solution:

In a side-by-side solution, there are many ways to combine the appliances. The width of the installation niche is calculated from the sum of the widths of the individual appliances. The height and depth of the installation niche correspond to the specifications for the individual appliances. It is important to comply with the dimensions in the area set aside for electric and water connections. For the precise dimensions, please refer to the details given for individual appliances.

Location

The appliance should be installed in a dry, well ventilated room. The location of the appliance should not be subject to direct sunlight or near a source of heat, such as a cooker, a radiator, etc. If installation next to a heat source is unavoidable or observe the following minimum distances from the heat source:

- 3 cm to electric or gas cookers.
- 3 cm to electric or gas ovens.
- 30 cm to an oil-fired or solid-fuel cooker.

The floor of the installation location must not give way; if required, reinforce floor. To ensure that the ice maker functions correctly, the appliance must be upright.

Surface

To ensure that the appliance is installed securely and functions properly, the surface must be level and even. The floor must consist of a hard, rigid material. The floor in the installation area must have the same height as the floor in the rest of the room. Due to the heavy weight of a fully loaded appliance, the floor beneath must be stable. If in doubt, consult an architect, structural engineer or construction expert.

Neighbouring cabinetry

The new appliance is screwed firmly in place with the neighbouring cabinet parts. Care should be taken to ensure that all cupboards onto which something is fastened, are connected firmly to the floor or the wall. The thickness of the plinth can be a maximum 19 mm.

Base area | Crown of the niche

Base area

Important!
Poor ventilation leads to damage to the appliance!
Under no circumstances is it permitted to cover the air inlets and the exhaust air outlets of the appliance in the lower base area. You must observe the minimum distance of 100 mm between the upper edge of the floor and the bottom edge of the cabinet door of the appliance. Take this into consideration also when adjusting the appliance feet.

In relation to the standard height, the maximum height of the base board is 102 mm. The plinth can be maximum 19 mm thick.

Adhesive connectors are supplied on the front panel of the appliance for fitting the base board.

The air inlets and the exhaust air outlets of the appliance are located above the base board. They must not be covered.

Base detail

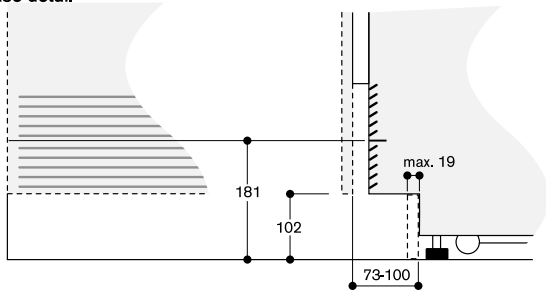

Based on the standard appliance height, the height of the plinth is 102 mm. Maximum plinth thickness 19 mm.

For design reasons, it may be necessary to increase the distance between the upper edge of the floor and the bottom edge of the cabinet door of the appliance, so that it extends beyond the standard dimension of 102 mm. The maximum dimension is 181 mm. If this is the case, air inlets and exhaust air outlets would become visible!

Crown

The height of the cabinet door on the appliance is dependent on:
– the overall height of the appliance,
– the distance from the bottom edge of the cabinet door to the floor,
– the appliance type (one-door or multi-door appliances).
The overall height of the appliance is 2.029 mm.

The height can be adjusted within a range of -13 mm to +35 mm. You must observe the minimum distance of 100 mm between the upper edge of the floor and the bottom edge of the cabinet door of the appliance.

This height can vary depending on the conditions at the site. It is possible, e.g. for design reasons, to lengthen the cabinet door upwards by extending it beyond the top of the appliance.

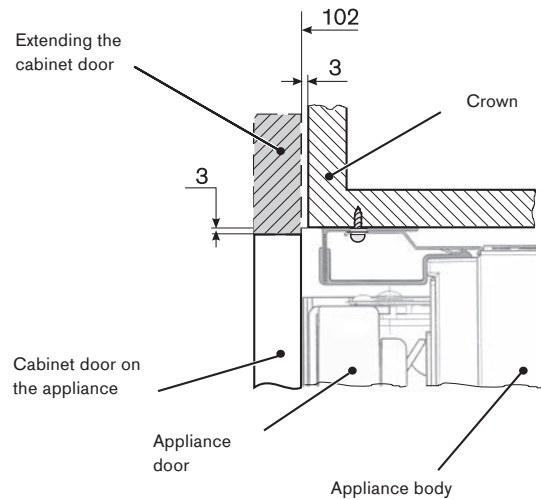

Important!
It must be ensured that the crown of the installation niche always has a depth of at least 100 mm (measured from the front edge of the appliance). Only then can the secure installation of the appliance in the installation niche be guaranteed.

The cabinetry, the height of the base board, the overall height of the kitchen and other determining dimensions of the kitchen must be taken into account, in order to plan the exact positioning of the cabinet door so that the appliance integrates perfectly into the overall picture of the kitchen.

The following diagrams show the basic dimensions of the special accessories door fronts/door front frames for various appliances.

The dimensions of the doors shown are designed for the following basic specifications:

- Height of the base board: 102 mm
- Overall height of the installation niche: 2.134 mm
- Gap: 3 mm
- Panel thickness: 19 mm

These specifications provide you with a good starting point for a variety of kitchen designs.

When designing a customised cabinet door, please ensure that the back of the cabinet door is visible to a height of 205 mm over the floor when opening the appliance door and adapt to the front design. All diagrams are also valid for doors without handle.

Important!

The following diagrams are not a substitute for detailed designs. Compliance with specified requirements relating to kitchen design is essential.

Recess width 45.7 cm

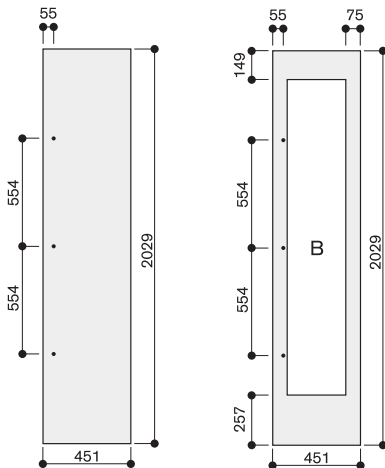

The door panel thickness is 19 mm.
The maximum door panel dimensions are based on a clearance of 3 mm, based on a single recess.
B: Width of the side frame parts of the door panel can be between 65 mm and 82 mm.

Recess width 91.4 cm

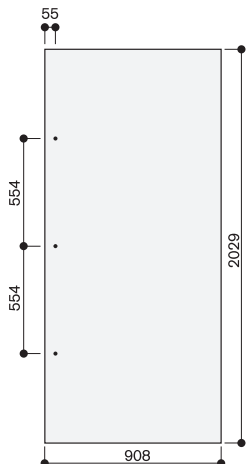

The door panel thickness is 19 mm.
The maximum door panel dimensions are based on a clearance of 3mm, based on a single recess.

Recess width 61 cm

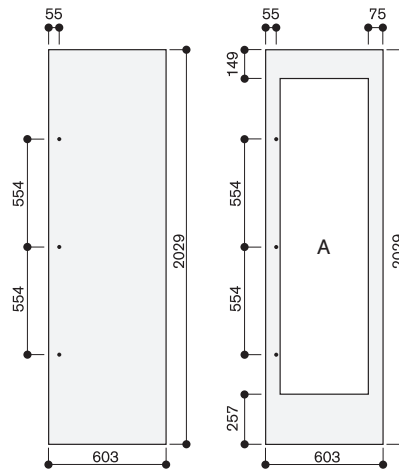

The door panel thickness is 19 mm.
The maximum door panel dimensions are based on a clearance of 3 mm, based on a single recess.
A: Width of the side frame parts of the door panel can be between 65 mm and 82 mm.

Recess width 76.2 cm

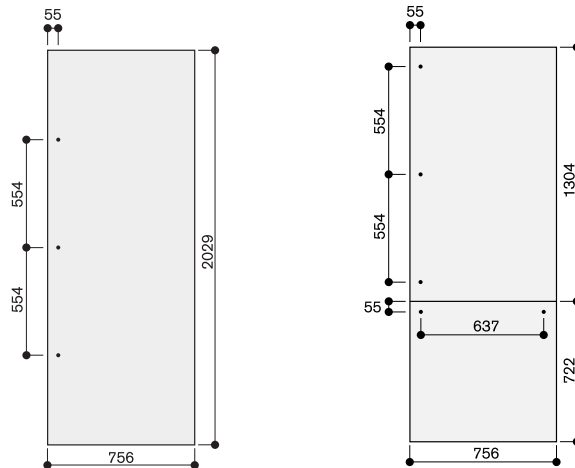

The door panel thickness is 19 mm.
The maximum door panel dimensions are based on a clearance of 3 mm, based on a single recess.

Recess width 91.4 cm

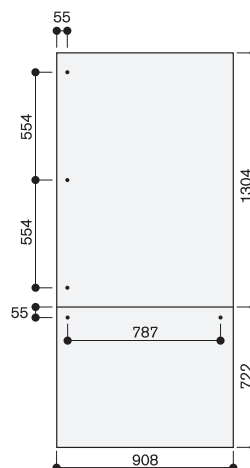

The door panel thickness is 19 mm.
The maximum door panel dimensions are based on a clearance of 3 mm, based on a single recess.

Planning principle for an individual appliance

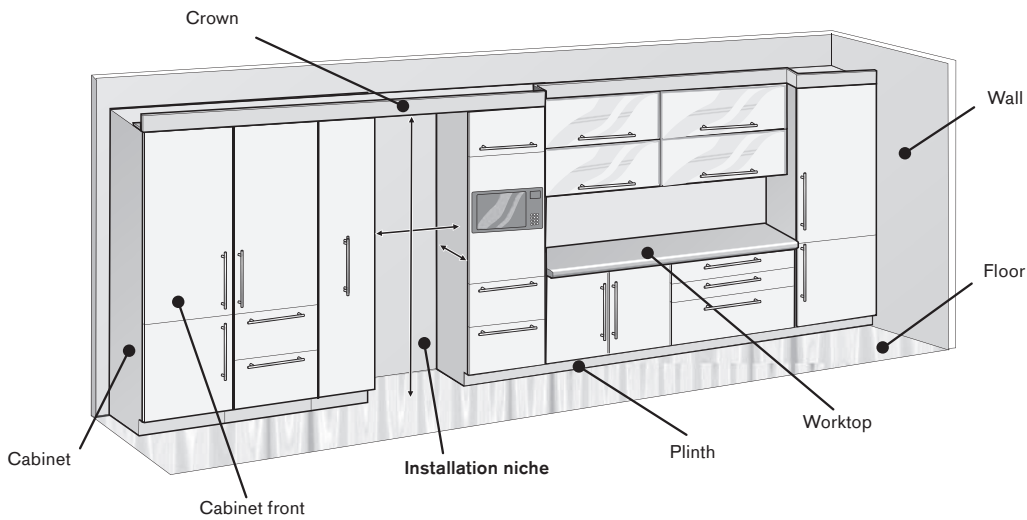

Vertical cut Installation niche

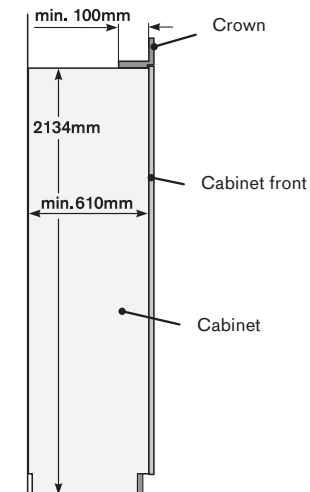

Installation niche for an individual cooling appliance (example: 762 mm wide)

In this example, the installation niche is formed by two tall cupboards (left and right) with an appropriate crown to the niche.

The cabinet door for the appliance comes in an identical design to the other kitchen fronts.

Requirements for the installation niche:

- The side walls of the installation niche must be completely even and flat along their entire depth
- Crown is at least 100 mm deep and made of a solid material (min. 16 mm thick)
- Width of the installation niche: 762 mm
- Depth of the installation niche: min. 610 mm

The side walls of the installation niche must be completely even and flat along their entire depth.

Horizontal cut Installation niche

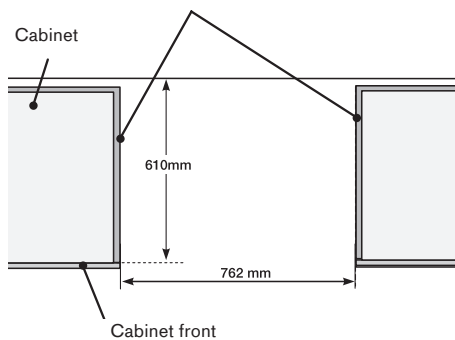

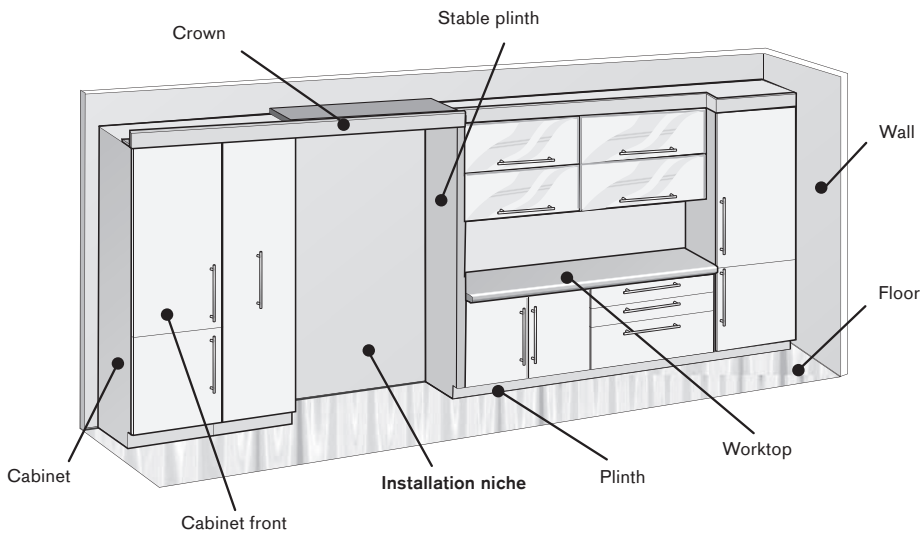

Vertical cut Installation niche

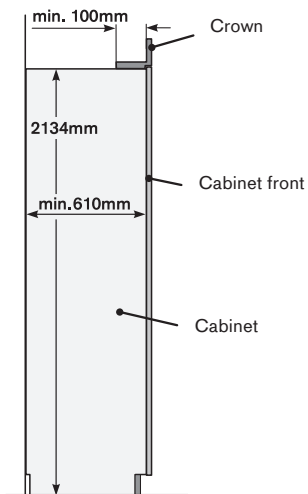

Installation niche for a side-by-side solution

- 610 mm cooling appliance (right)
- 457 mm freezer (left)

In this example, the installation niche is formed by a tall cupboard (left) and a stable plinth (right) together with an appropriate crown for the niche.

The cabinet door for both appliances comes in an identical design to the other kitchen fronts.

Requirements for the installation niche:

- The side walls of the installation niche must be completely even and flat along their entire depth
- Crown is at least 100 mm deep and made of a solid material (min. 16 mm thick)
- Width of the installation niche:
610 mm + 457 mm = 1.067 mm
- Depth of the installation niche: min. 610 mm

The side walls of the installation niche must be completely even and flat along their entire depth.

Horizontal cut Installation niche

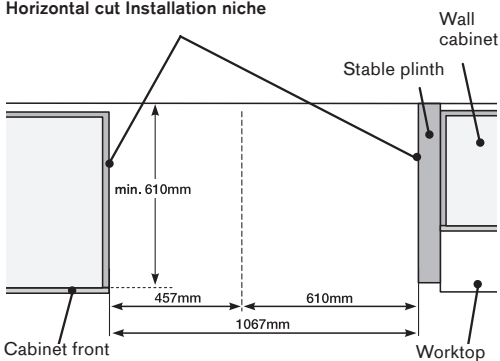

Planning examples for Vario cooling 400 series

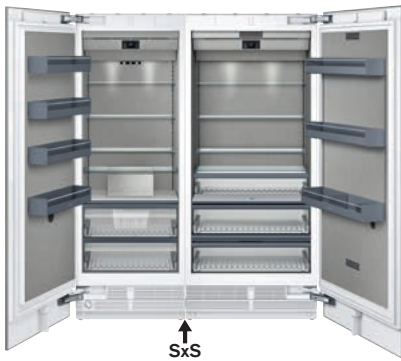

Side-by-side solution 1

RF 471 / RC 492

Usability limitations: No limitation.

Installation accessories: 1x RA 460 000 installation accessories for side-by-side installation (SxS)*.

Notes: Door hinges on the outside.



Side-by-side solution 2

RW 414 / RB 472

Usability limitations: No limitation.

Installation accessories: 1x RA 460 000 installation accessories for side-by-side installation (SxS)*.

Notes: Door hinges on the outside. Change door hinge of RW.

If using the stainless steel door panels with a handle (installation accessories), select the correct panel for the intended hinge side of the RW.



Combination of 3

RF 461 / RW 466 / RC 462

Usability limitations: The doors of RW and RC cannot be opened at the same time, but one after another.

Installation accessories: 2x RA 460 000 installation accessories for side-by-side installation (SxS)*.

Notes: All three appliances must be connected to each other before installation and pushed together into the installation niche.



Maximum distance

RF 471 / RW 466 / RW 466 / RC 472

Usability limitations: No limitation. All doors can be opened fully.

Installation accessories: 2x RA 460 000 (SxS)*.

Notes: Two separate installation niches. Clearance is large enough to open all doors at the same time. Change door hinge of one of the RW 466.

If using the stainless steel door panels with a handle (installation accessories), select the correct panel for the intended hinge side of the RW.



Distance \geq 160 mm

RF 471 / RC 472 / RW 466 / RW 466

Usability limitations: The middle doors cannot be opened at the same time.

Installation accessories: 2x RA 460 000 (SxS)*.

Notes: Two separate installation niches. The clearance between the two installation niches is greater than 160 mm. Change door hinge of RW.

If using the stainless steel door panels with a handle (installation accessories), select the correct panel for the intended hinge side of the RW.

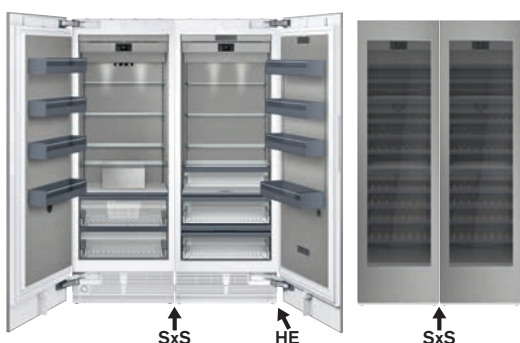

Distance \leq 160 mm

RF 471 / RC 472 / RW 466 / RW 466

Usability limitations: It may be necessary to open the middle doors one after the other, rather than at the same time.

Installation accessories: 2x RA 460 000 (SxS)*, 1x RA 460 013 (HE)*.

Notes: Two separate installation niches with a stable plinth between them. The clearance between the two installation niches is less than 160 mm. Therefore, an additional side heating element is required. Change door hinge of RW. If using the stainless steel door panels with handle (installation accessories), select the correct panel for the intended hinge side of the RW.



Combination of 4

RF 471 / RW 466 / RW 466 / RC 472

Usability limitations: If the middle doors are open, then neither of the outer doors can be opened.

Installation accessories: 3x RA 460 000 installation accessories for side-by-side installation (SxS)*.

Notes: The appliances in the middle are connected side-by-side. Connecting the others will require additional side-by-side installation accessories. All four appliances must be connected to each other before installation and pushed together into the installation niche.



Combination of 4 - alternative

RF 471 / RW 466 / RW 466 / RC 472

Usability limitations: The middle doors cannot be opened at the same time.

Installation accessories: 3x RA 460 000 installation accessories for side-by-side installation (SxS)*.

Notes: The appliances in the middle are connected hinge to hinge. All four appliances must be connected to each other before installation and pushed together into the installation niche. If using the stainless steel door panels with handle (installation accessories), select the correct panel for the intended hinge side of the RW.

Footnote:

*SxS Accessory for side-by-side installation. In a very humid environment always use the additional side heating element instead of the accessory for side-by-side installation.

*HE Additional side heating element. Always required, if the distance between the appliances is greater than 16 mm or less than 160 mm.



RB 289 300

With fresh cooling close to 0 °C
Fully integrated
Niche width 56 cm,
Niche height 177.5 cm



Included in the price

- 2 bottle supports, maple wood
- 2 egg trays
- 1 ice cube tray
- 2 ice packs

Special accessories

RA 430 100

Storage container with transparent lid, anthracite.

RA 238 030

Solid maple bottle support with magnetic connector, oiled.

RA 260 000

Heavy duty hinge support for a maximum door weight of 24 kg.

Vario fridge-freezer combination 200 series

RB 289

- Interior with precision-fitted, solid aluminium elements in Gaggenau Light Bronze
- Extendable shelves and drawers
- Warm white and glare-free LED light
- 4 climate zones incl. 2 fresh cooling drawers close to 0 °C
- Height-adjustable, extendable safety glass shelves, set in solid aluminium profiles
- Cushioned door closing system allowing a soft and controlled door closure
- Easy-glide, fully extendable telescopic pull-out racks and a cushioned closing system allowing soft and controlled drawer closure
- Solid maple bottle supports with magnetic connector
- Total volume 223 litres

Handling

Electronic temperature control with digital display.
Touch keys.

Technical features

Automatic defrosting with defrost water evaporation.

Cushioned door closing system from 20° door opening angle, integrated in door hinge.

Open-door and malfunction alarm.

Holiday mode.

Selected digital services (Home Connect)

Remote control and monitoring.

Please read additional information on Home Connect on page 411.

Cooling

Fast cooling.

Temperature adjustable from +3 °C to +8 °C.

2 height-adjustable safety glass shelves, partly extendable.

1 frosted white glass shelf.

2 oiled, solid maple bottle supports with magnetic connector, can be increased to 5 supports per shelf.

A total of 9 bottles (based on a 0.75 l bottle) can be stored on one level using 5 bottle supports.

The bottle supports are also suitable for storing champagne bottles and magnums.

1 large aluminium door rack for bottles.
1 aluminium door rack.

Warm white interior lighting (3500 K) with integrated glare-free LED side lights.
Volume 101 litres.

Fresh cooling close to 0 °C

Drawers with solid aluminium handles and signature drawer front with a gradual frosted surface.

1 fully extendable fresh cooling drawer close to 0 °C, illuminated.

Humidity can be adjusted manually.
Ideal for fruit and vegetables.

1 fully extendable fresh cooling drawer close to 0 °C, illuminated.

Ideal for meat, fish and poultry.
Volume 55 litres.

Freezing

No-frost technology with fast freezing.
Temperature adjustable from -24 °C to -14 °C.

4-star freezer compartment.

Drawers with solid aluminium handles and signature drawer front with a gradual frosted surface.

Defrost assistance.

Freezing capacity 7 kg/24 h.

Storage time after a malfunction 8 h.

3 freezer drawers, 1 of which extra large.

2 safety glass shelves.

Volume 67 litres.

Consumption data

Energy efficiency class D at a range of energy efficiency classes from A to G.

Energy consumption 201 kWh/year.

Noise level 37 dB (A) re 1 pW.

Planning notes

Flat hinge.

Door hinge right, reversible.

Door opening angle of 115°, fixable at 90°.

Max. door panel weight:

Upper door 19 kg. Lower door 19 kg.

Please read additional planning notes on page 349.

Connection

Total connected load 0.090 kW.

Connecting cable 2.3 m with plug.

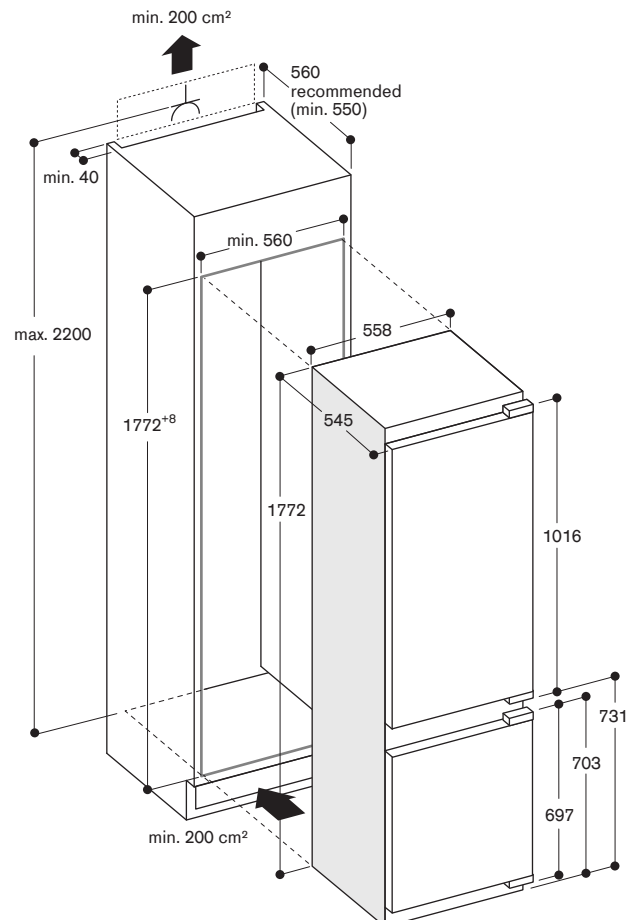

**RT 289 370**

With fresh cooling close to 0 °C
Fully integrated
Niche width 56 cm,
Niche height 177.5 cm

**Included in the price**

2 bottle supports, maple wood
2 egg trays
1 ice cube tray
1 heavy duty hinge support

Special accessories**RA 430 100**

Storage container with transparent lid,
anthracite.

RA 238 030

Solid maple bottle support with
magnetic connector, oiled.

**Vario fridge-freezer combination
200 series**
RT 289

- Interior with precision-fitted, solid aluminium elements in Gaggenau Light Bronze
- Opening assist for door:
 1. Push-to-open function for integration into handleless furniture front
 2. Door opening via voice assistant possible
- Extendable shelves and drawers
- 4 climate zones incl. 3 fresh cooling drawers close to 0 °C
- Height-adjustable, extendable safety glass shelves, set in solid aluminium profiles
- Easy-glide, fully extendable telescopic pull-out racks and a cushioned closing system allowing soft and controlled drawer closure
- Solid maple bottle supports with magnetic connector
- Total volume 269 litres

Handling

Electronic temperature control with digital display.
Touch keys.

Technical features

Automatic defrosting with defrost water evaporation.
Cushioned door closing system from 20° door opening angle, integrated in door hinge.
Open-door and malfunction alarm.

**Selected digital services
(Home Connect)**

Remote control and monitoring.
Door opening via voice assistant.

Please read additional information on Home Connect on page 411.

Cooling

Fast cooling.
Temperature adjustable from +3 °C to +8 °C.
5 height-adjustable safety glass shelves, partly extendable.
1 frosted white glass shelf.
2 oiled, solid maple bottle supports with magnetic connector, can be increased to 5 supports per shelf.
A total of 9 bottles (based on a 0.75l bottle) can be stored on one level using 5 bottle supports.
The bottle supports are also suitable for storing champagne bottles and magnums.
1 large aluminium door rack for bottles.
3 aluminium door racks.
Warm white interior lighting (3500 K) with integrated glare-free LED side lights.
Volume 171 litres.

Fresh cooling close to 0 °C

Drawers with solid aluminium handles and signature drawer front with a gradual frosted surface.
1 fully extendable fresh cooling drawer close to 0 °C, illuminated.
Humidity can be adjusted manually.
Ideal for fruit and vegetables.
2 fully extendable fresh cooling drawers close to 0 °C, illuminated.
Ideal for meat, fish and poultry.
Volume 83 litres.

Freezing

Storage temperature -18 °C and lower.
4-star freezer compartment.
Freezing capacity 2.8 kg/24 h.
Storage time after a malfunction 9.5 h.
Volume 15 litres.

Consumption data

Energy efficiency class E at a range of energy efficiency classes from A to G.
Energy consumption 184 kWh/year.
Noise level 36 dB (A) re 1 pW.

Planning notes

Flat hinge.
Door hinge right, reversible.
Door opening angle of 115°, fixable at 90°.
Max. door panel weight 27 kg.

Please read additional planning notes on page 349.

Connection

Total connected load 0.090 kW.
Connecting cable 2.3 m with plug.

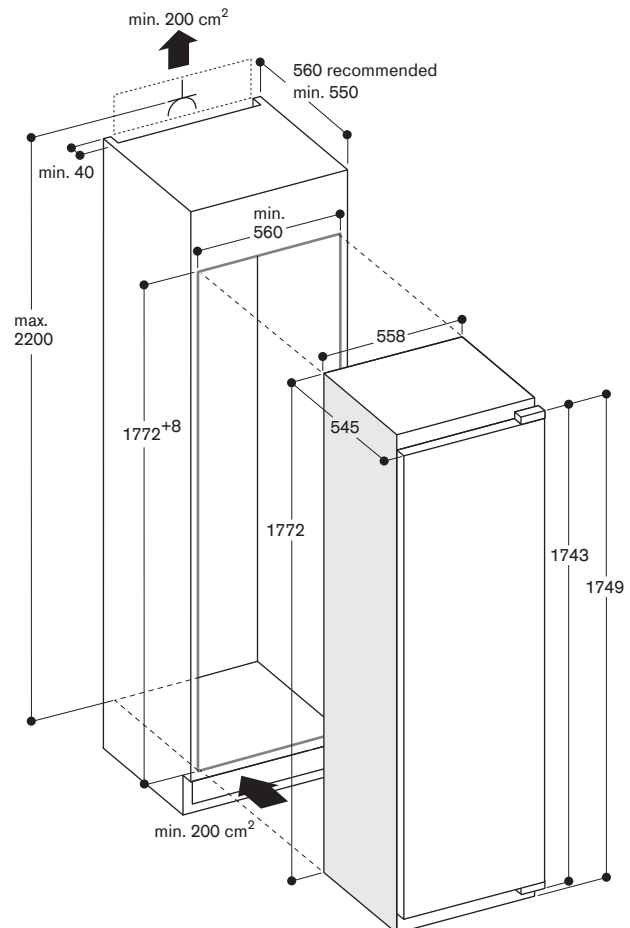



RC 289 370

With fresh cooling close to 0 °C
Fully integrated
Niche width 56 cm,
Niche height 177.5 cm



Included in the price

2 bottle supports, maple wood
2 egg trays
1 heavy duty hinge support

Special accessories

RA 430 100

Storage container with transparent lid, anthracite.

RA 238 030

Solid maple bottle support with magnetic connector, oiled.

Vario refrigerator 200 series

RC 289

- Interior with precision-fitted, solid aluminium elements in Gaggenau Light Bronze
- Opening assist for door:
 1. Push-to-open function for integration into handleless furniture front
 2. Door opening via voice assistant possible
- Extendable shelves and drawers
- 3 climate zones incl. 3 fresh cooling drawers close to 0 °C
- Height-adjustable, extendable safety glass shelves, set in solid aluminium profiles
- Combines with freezer RF287 (side-by-side integration)
- Cushioned door closing system allowing a soft and controlled door closure
- Easy-glide, fully extendable telescopic pull-out racks and a cushioned closing system allowing soft and controlled drawer closure
- Solid maple bottle supports with magnetic connector
- Total volume 289 litres

Handling

Electronic temperature control with digital display.
Touch keys.

Technical features

Automatic defrosting with defrost water evaporation.
Cushioned door closing system from 20° door opening angle, integrated in door hinge.
Open-door and malfunction alarm.

Selected digital services (Home Connect)

Remote control and monitoring.
Door opening via voice assistant.

Please read additional information on Home Connect on page 411.

Cooling

Fast cooling.
Temperature adjustable from +3 °C to +8 °C.
6 safety glass shelves, height adjustable, partly extendable.
1 frosted white glass shelf.
2 oiled, solid maple bottle supports with magnetic connector, can be increased to 5 supports per shelf.
A total of 9 bottles (based on a 0.75l bottle) can be stored on one level using 5 bottle supports.
The bottle supports are also suitable for storing champagne bottles and magnums.
1 large aluminium door rack for bottles.
3 aluminium door racks.
Warm white interior lighting (3500 K) with integrated glare-free LED side lights.
Volume 206 litres.

Fresh cooling close to 0 °C

Drawers with solid aluminium handles and signature drawer front with a gradual frosted surface.
1 fully extendable fresh cooling drawer close to 0 °C, illuminated.
Humidity can be adjusted manually.
Ideal for fruit and vegetables.
2 fully extendable fresh cooling drawers close to 0 °C, illuminated.
Ideal for meat, fish and poultry.
Volume 83 litres.

Consumption data

Energy efficiency class D at a range of energy efficiency classes from A to G.
Energy consumption 120 kWh/year.
Noise level 36 dB (A) re 1 pW.

Planning notes

Flat hinge.
Door hinge right, reversible.
Door opening angle of 115°, fixable at 90°.
Max. door panel weight 27 kg.
For a side-by-side installation every appliance must be planned in its own niche.

Please read additional planning notes on page 349.

Connection

Total connected load 0.090 kW.
Connecting cable 2.3 m with plug.

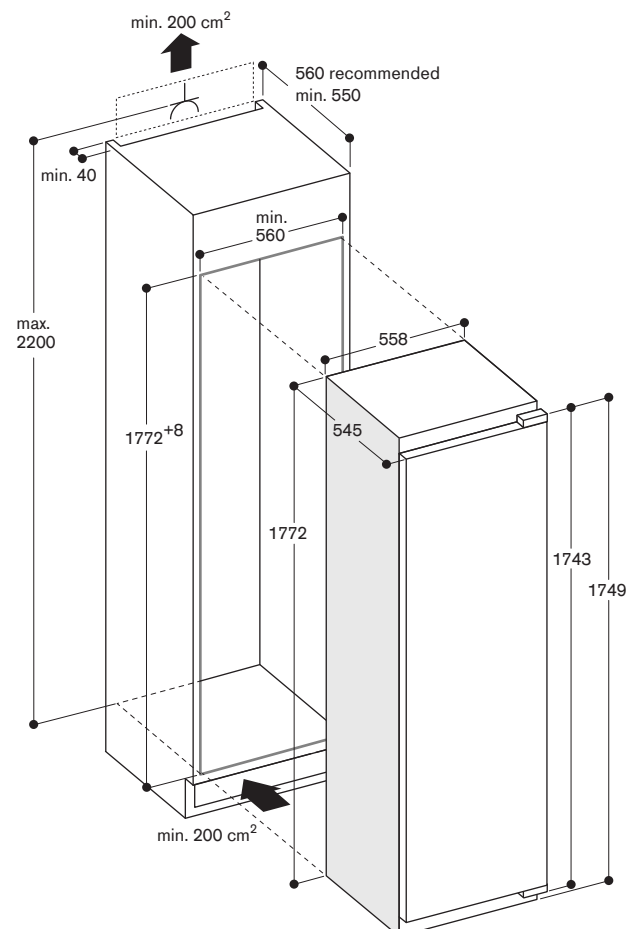



RF 287 370
Fully integrated
Niche width 56 cm,
Niche height 177.5 cm



Included in the price

- 1 ice cube tray
- 1 heavy duty hinge support

Vario freezer 200 series

RF 287

- Interior with precision-fitted, solid aluminium elements in Gaggenau Light Bronze
- Opening assist for door:
 1. Push-to-open function for integration into handleless furniture front
 2. Door opening via voice assistant possible
- Safety glass shelves, set in solid aluminium profiles
- Drawers with solid aluminium handles and signature drawer front with a gradual frosted surface
- Warm white interior lighting (3500 K) with integrated glare-free LED side lights
- Direct access through open storage areas
- Combines with fridge RC 289 (side-by-side integration)
- Combines with wine climate cabinet RW 282 (side-by-side integration)
- Cushioned door closing system allowing a soft and controlled door closure
- Total volume 212 litres

Handling

Electronic temperature control with temperature display.
Touch keys.

Technical features

Dynamic cold air distribution.
Cushioned door closing system from 20° door opening angle, integrated in door hinge.
Open-door and malfunction alarm.

Selected digital services (Home Connect)

Remote control and monitoring.
Door opening via voice assistant.

Please read additional information on Home Connect on page 411.

Freezing

No-frost technology with fast freezing.
Temperature adjustable from -24 °C to -14 °C.
4-star freezer compartment.
Freezing capacity 14 kg/24 h.
Storage time after a malfunction 9 h.
3 freezer drawers, 1 of which is extra large, removable.
6 safety glass shelves, 3 of which are set in solid aluminium profiles, removable.

Consumption data

Energy efficiency class E at a range of energy efficiency classes from A to G.
Energy consumption 235 kWh/year.
Noise level 35 dB (A) re 1 pW.

Planning notes

Flat hinge.
Door hinge left, reversible.
Door opening angle of 115°, fixable at 90°.
Max. door panel weight 27 kg.
For a side-by-side installation every appliance must be planned in its own niche.

Please read additional planning notes on page 349.

Connection

Total connected load 0.120 kW.
Connecting cable 2.3 m with plug.

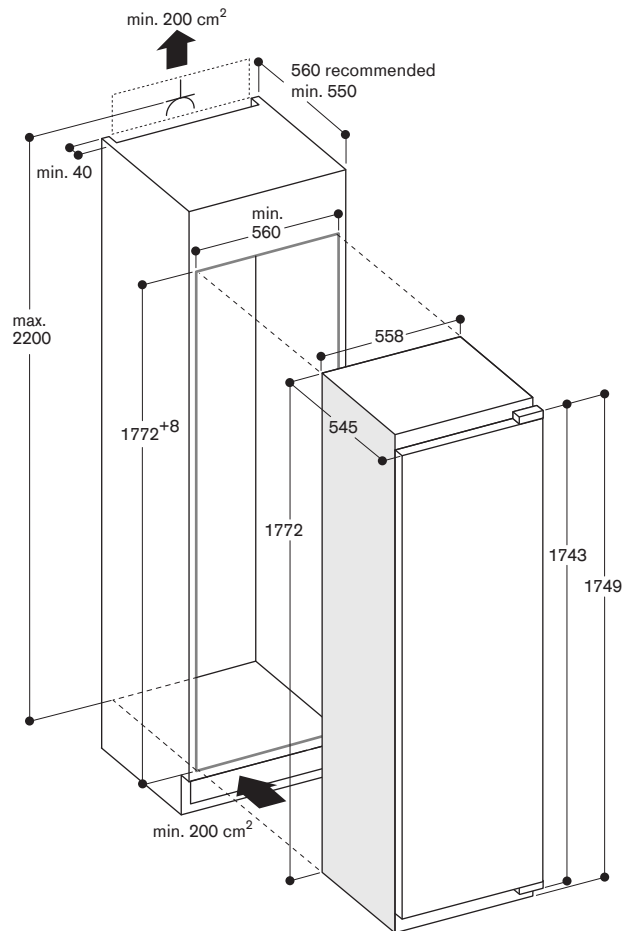



RY 295 350

With fresh cooling 0 °C

Freestanding

Front doors and drawer in anthracite stainless steel

Width 91 cm, height 183 cm



Included in the price

1 ice cube scoop

1 activated charcoal filter

Special accessories

RA 450 012

Activated charcoal water filter

For RVY, RY, RB and RF.

Freestanding fridge-freezer combination 200 series

RY 295

- 3 climate zones incl. fresh cooling 0 °C
- 2 fresh cooling drawer 0 °C with 5 preset temperature settings between -2 °C and +4 °C
- 3 symmetrically split glass shelves, height adjustable
- Integrated ice maker with fixed inlet water connection
- Internal water dispenser for chilled water
- 5 preset brightness settings for the lighting
- Total volume 573 litres

Handling

Electronic temperature control with temperature display.

Touch keys.

Technical features

Dynamic cold air distribution.

Automatic defrosting with defrost water evaporation.

Open-door and malfunction alarm.

Child lock.

Rest mode certified by Star-K.

Holiday mode.

Dark anthracite coloured top and side panels outside.

Activated charcoal filter for water filter system with saturation indicator shown in display.

Air filter.

Selected digital services

(Home Connect)

Remote control and monitoring.

Please read additional information on Home Connect on page 411.

Cooling

Fast cooling.

Temperature adjustable from +2 °C to +8 °C.

3 split safety glass shelves, all 6 half shelves with manual height adjustment.

1 integrated shelf.

2 large door racks for bottles.

4 door racks, 2 of which are height adjustable.

1 full width drawer.

Internal water dispenser with fixed inlet water connection, integrated in left side wall.

Glare-free LED lighting (5600 K).

5 preset brightness settings for the lighting, also via Home Connect.

Interior stainless steel back wall.

Volume 335 litres.

Fresh cooling 0 °C

2 fresh cooling 0 °C drawers.

5 preset temperature settings between -2 °C and +4 °C combined with humidity setting for fish and meat, fruit, vegetables, beverages, standard.

Volume 67 litres.

Freezing

No-Frost technology with fast freezing.

Temperature adjustable from

-24 °C to -16 °C.

4-star freezer compartment.

Freezing capacity 15 kg /24 h.

Storage time after a malfunction 18.5 h.

3 fully extendable drawers.

Volume 171 litres.

Ice maker

Integrated in the freezer compartment, with fixed inlet water connection.

Can be switched off manually.

Ice cube production approx. 1.5kg/24 h.

Removable ice storage container with

approx. 3 kg capacity.

Consumption data

Energy efficiency class E at a range of energy efficiency classes from A to G.

Energy consumption 333 kWh/year.

Noise level 39 dB (A) re 1 pW.

Planning notes

Door opening angle of 118°, fixable at 90°.

Wall recess of 25 mm necessary.

If the water pressure exceeds 0.8 MPa (8 bar), connect pressure relief valve between water tap and hose set.

To achieve the declared energy consumption, the attached spacers have to be used. The spacers increase the appliance depth by about 2.5 cm.

Without the spacers, the appliance is fully functional but consumes slightly more energy.

Connection

Connecting cable 2.4 m with plug.

Water inlet.

Supply hose 3.0 m with 3/4 " connection.

Water pressure 2 to 8 bar.

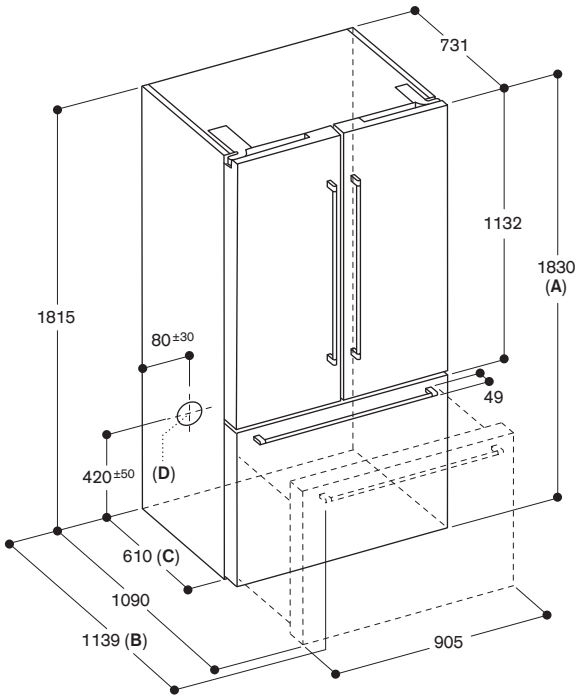

- A: Front is adjustable from 1830 to 1847, with front levelling feet fully extended.
- B: With handle
- C: Add 25 mm for fixed spacers on back
- D: Water connection position

measurements in mm

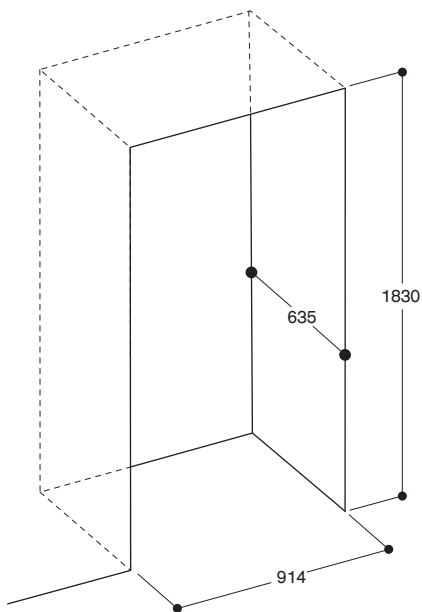

If you install the appliance in a niche, adhere to the shown dimensions

measurements in mm

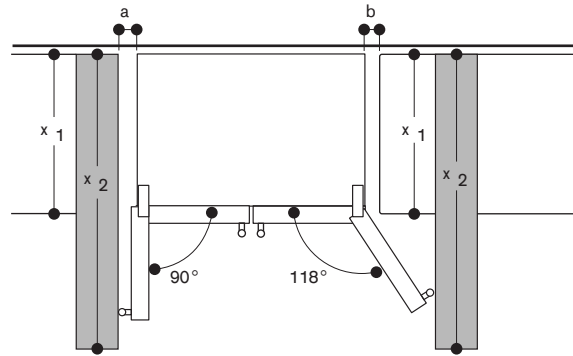

x ₁ (unit depth)	a	b
600	0	0
650	0	33
700	45	60
x ₂ (wall)	93	266

measurements in mm

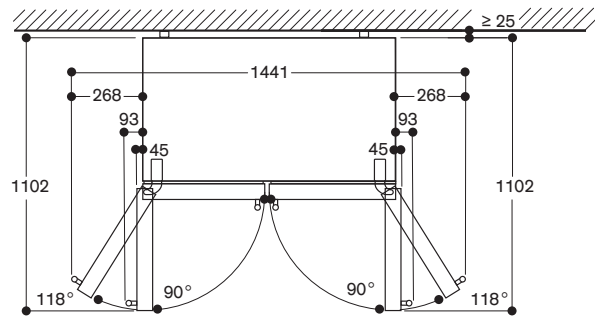

measurements in mm

Minimum Clearances

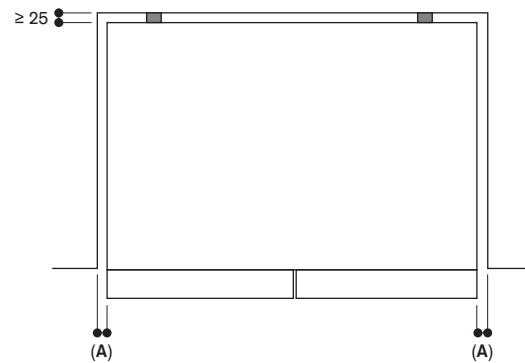

A: ≥ 3.2 mm

Leave a clearance of min. 12.7 mm above the appliance. Observe minimum clearances as seen above

measurements in mm



RB 282 306

With fresh cooling close to 0 °C
Fully integrated
Niche width 56 cm,
Niche height 177.5 cm



Included in the price

- 2 ice packs
- 3 egg trays
- 1 wine and champagne rack
- 1 ice cube tray with lid

Special accessories

RA 430 100

Storage container with transparent lid, anthracite.

RA 260 000

Heavy duty hinge support for a maximum door weight of 24 kg.

Fridge-freezer combination 200 series RB 282

- 4 climate zones incl. 2 fresh cooling drawers close to 0 °C
- Height adjustable safety glass shelves
- Door racks with aluminium profiles
- Cushioned door closing system allowing a soft and controlled door closure
- Total volume 223 litres

Handling

Electronic temperature control with digital display.
Touch keys.

Technical features

Automatic defrosting with defrost water evaporation.
Cushioned door closing system from 20° door opening angle, integrated in door hinge.
Open-door and malfunction alarm.
Holiday mode.

Selected digital services (Home Connect)

Remote control and monitoring.

Please read additional information on Home Connect on page 411.

Cooling

Fast cooling.
Temperature adjustable from +3 °C to +8 °C.
2 safety glass shelves, height adjustable, of which 1 is extendable.
1 integrated shelf.
Wine and champagne rack for 4 bottles, can be completely folded.
1 large door rack with aluminium profile for bottles with flexible bottle holder.
1 door rack with aluminium profile.
Bright interior lighting (5800 K) with integrated glare-free LED side light element.
Volume 101 litres.

Fresh cooling close to 0 °C

1 fully extendable fresh cooling drawer close to 0 °C, illuminated.
Humidity can be adjusted manually.
Ideal for fruit and vegetables.
1 fully extendable fresh cooling drawer close to 0 °C, illuminated.
Ideal for meat, fish and poultry.
Volume 55 litres.

Freezing

No-Frost technology with fast freezing.
Temperature adjustable from -24 °C to -16 °C.
4-star freezer compartment.
Defrost assistance.
Freezing capacity 7 kg/24 h.
Storage time after a malfunction 8 h.
3 freezer drawers, 1 of which extra large.
2 safety glass shelves.
Volume: 67 litres.

Consumption data

Energy efficiency class D at a range of energy efficiency classes from A to G.
Energy consumption 201 kWh/year.
Noise level: 37 dB (A) re 1 pW.

Planning notes

Flat hinge.
Door hinge right, reversible.
Door opening angle of 115°, fixable at 90°.
Max. door panel weight:
Upper door 19 kg.
Lower door 19 kg.

Please read additional planning notes on page 349.

Connection

Total connected load 0.090 kW.
Connecting cable 2.3 m with plug.

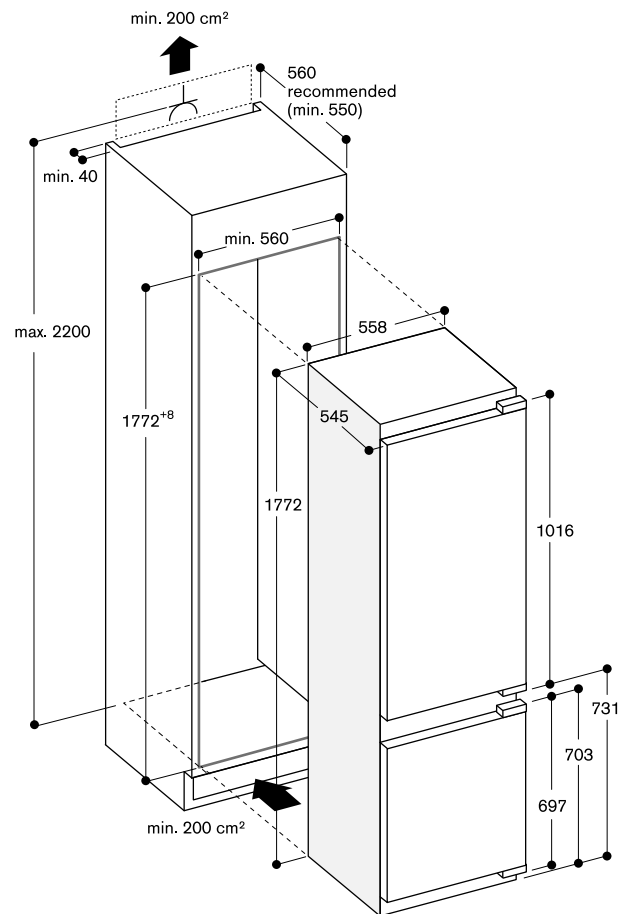

**RT 282 306**

With fresh cooling close to 0 °C
Fully integrated
Niche width 56 cm,
Niche height 177.5 cm

**Included in the price**

3 egg trays
1 wine and champagne rack
1 ice cube tray with lid

Special accessories**RA 430 100**

Storage container with transparent lid,
anthracite.

RA 260 000

Heavy duty hinge support for a
maximum door weight of 27 kg.

Fridge-freezer combination 200 series**RT 282**

- 4 climate zones incl. 3 fresh cooling drawers close to 0 °C
- Height adjustable safety glass shelves
- Door racks with aluminium profiles
- Cushioned door closing system allowing a soft and controlled door closure
- Total volume 269 litres

Handling

Electronic temperature control with digital display.
Touch keys.

Technical features

Automatic defrosting with defrost water evaporation.
Cushioned door closing system from 20° door opening angle, integrated in door hinge.
Open-door and malfunction alarm.

Selected digital services (Home Connect)

Remote control and monitoring.

Please read additional information on Home Connect on page 411.

Cooling

Fast cooling.
Temperature adjustable from +3 °C to +8 °C.
5 safety glass shelves, height adjustable, of which 1 is extendable.
1 integrated shelf.
Wine and champagne rack for 4 bottles, can be completely folded away.
1 large door rack with aluminium profile for bottles with flexible bottle holder.
4 door racks with aluminium profile.
Bright interior lighting (5800 K) with integrated glare-free LED side light element.
Volume 171 litres.

Fresh cooling close to 0 °C

1 fully extendable fresh cooling drawer close to 0 °C, illuminated.
Humidity can be adjusted manually.
Ideal for fruit and vegetables.
2 fully extendable fresh cooling drawers close to 0 °C, illuminated.
Ideal for meat, fish and poultry.
Volume 83 litres.

Freezing

Storage temperature -18 °C and lower.
4-star freezer compartment.
Freezing capacity 2.8 kg/24 h.
Storage time after a malfunction 9.5 h.
Volume 15 litres.

Consumption data

Energy efficiency class E at a range of energy efficiency classes from A to G.
Energy consumption 184 kWh/year.
Noise level: 36 dB (A) re 1 pW.

Planning notes

Flat hinge.
Door hinge right, reversible.
Door opening angle of 115°, fixable at 90°.
Max. door panel weight 22 kg.

Please read additional planning notes on page 349.

Connection

Total connected load 0.090 kW.
Connecting cable 2.3 m with plug.

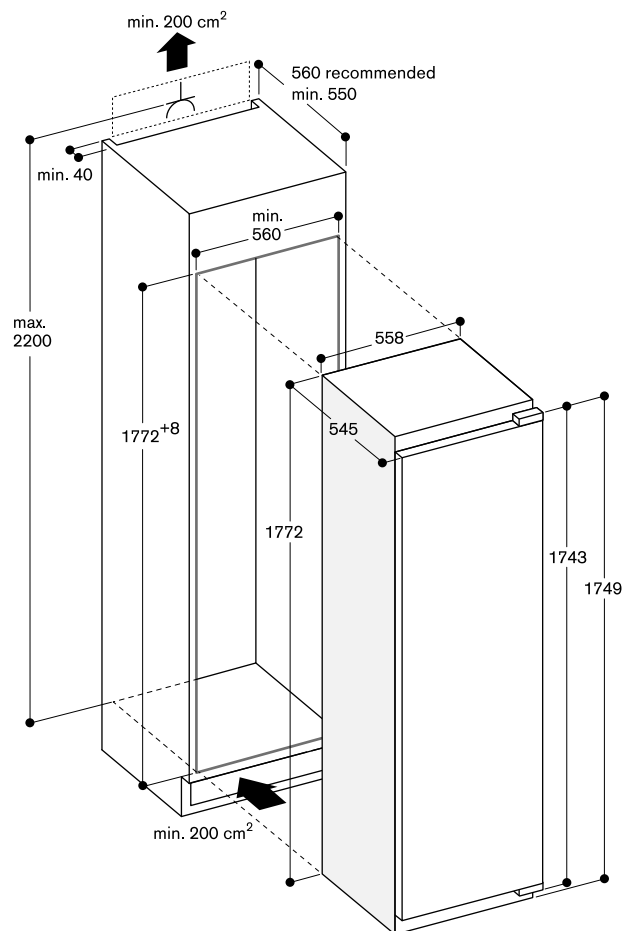



RC 282 306

With fresh cooling close to 0 °C
Fully integrated
Niche width 56 cm,
Niche height 177.5 cm



Included in the price

3 egg trays
1 wine and champagne rack

Special accessories

RA 430 100
Storage container with transparent lid,
anthracite.

RA 260 000

Heavy duty hinge support for a
maximum door weight of 27 kg.

Refrigerator 200 series

RC 282

- 3 climate zones incl. 3 fresh cooling drawers close to 0 °C
- Height adjustable safety glass shelves
- Door racks with aluminium profiles
- Combines with freezer RF282 (side-by-side integration)
- Cushioned door closing system allowing a soft and controlled door closure
- Total volume 289 litres

Handling

Electronic temperature control with digital display.
Touch keys.

Technical features

Automatic defrosting with defrost water evaporation.
Cushioned door closing system from 20° door opening angle, integrated in door hinge.
Open-door and malfunction alarm.

Selected digital services (Home Connect)

Remote control and monitoring.

Please read additional information on Home Connect on page 411.

Cooling

Fast cooling.
Temperature adjustable from +3 °C to +8 °C.
6 safety glass shelves, height adjustable, of which 1 is extendable.
1 integrated shelf.
Wine and champagne rack for 4 bottles, can be completely folded.
1 large door rack with aluminium profile for bottles with flexible bottle holder.
4 door racks with aluminium profile.
Bright interior lighting (5800 K) with integrated glare-free LED side light element.
Volume 206 litres.

Fresh cooling close to 0 °C

1 fully extendable fresh cooling drawer close to 0 °C, illuminated.
Humidity can be adjusted manually.
Ideal for fruit and vegetables.
2 fully extendable fresh cooling drawers close to 0 °C, illuminated.
Ideal for meat, fish and poultry.
Volume 83 litres.

Consumption data

Energy efficiency class D at a range of energy efficiency classes from A to G.
Energy consumption 120 kWh/year.
Noise level: 36 dB (A) re 1 pW.

Planning notes

Flat hinge.
Door hinge right, reversible.
Door opening angle of 115°, fixable at 90°.
Max. door panel weight 22 kg.
For a side-by-side installation every appliance must be planned in its own niche.

Please read additional planning notes on page 349.

Connection

Total connected load 0.090 kW.
Connecting cable 2.3 m with plug.

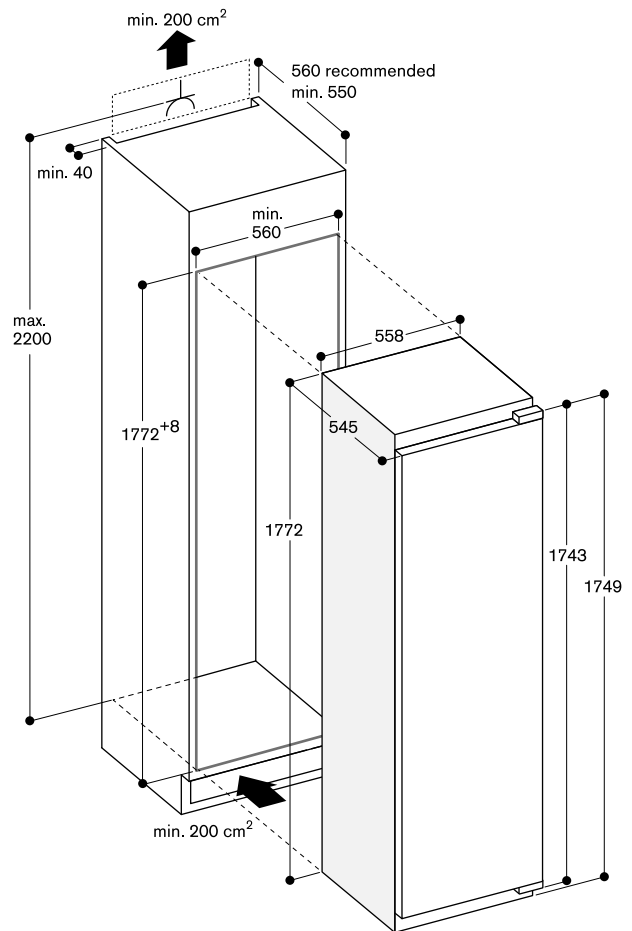



RF 282 306
Fully integrated
Niche width 56 cm,
Niche height 177.5 cm



Included in the price
1 ice cube tray

Special accessories
RA 260 000
Heavy duty hinge support for a
maximum door weight of 27 kg.

Freezer 200 series RF 282

- Flexible interior configuration: all drawers and safety glass shelves can be removed
- Combines with fridge RC282 (side-by-side integration)
- Combines with wine climate cabinet RW 282 (side-by-side integration)
- Cushioned door closing system allowing a soft and controlled door closure
- Total volume 212 litres

Handling

Electronic temperature control with temperature display.
Touch keys.

Technical features

Dynamic cold air distribution.
Cushioned door closing system from 20° door opening angle, integrated in door hinge.
Open-door and malfunction alarm.

Selected digital services (Home Connect)

Remote control and monitoring.

Please read additional information on Home Connect on page 411.

Freezing

No-Frost technology with fast freezing.
Temperature adjustable from -24 °C to -14 °C.
4-star freezer compartment.
Freezing capacity 13.8 kg/24 h.
Storage time after a malfunction 8 h.
5 freezer drawers, 2 of which extra large.
4 safety glass shelves between the freezer drawers.
2 safety glass shelves with transparent front flap.
All freezer drawers and safety glass shelves can be removed.
Volume 212 litres.

Consumption data

Energy efficiency class E at a range of energy efficiency classes from A to G.
Energy consumption 235 kWh/year.
Noise level: 35 dB (A) re 1 pW.

Planning notes

Flat hinge.
Door hinge left, reversible.
Door opening angle of 115°, fixable at 90°.
Max. door panel weight 22 kg.
For a side-by-side installation every appliance must be planned in its own niche.

Please read additional planning notes on page 349.

Connection

Total connected load 0.120 kW.
Connecting cable 2.3 m with plug.

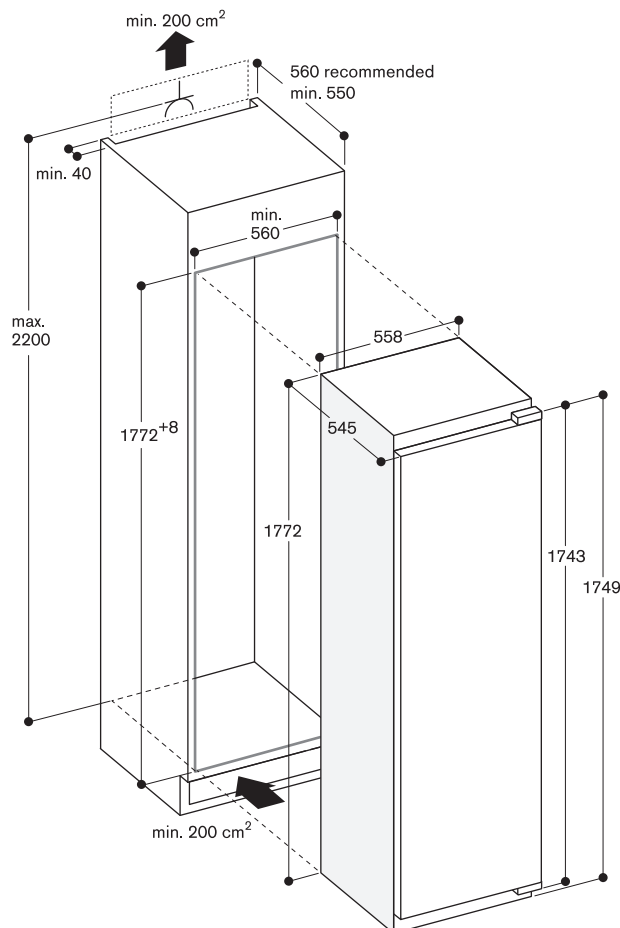



RT 202 180

Fully integrated, under-counter
Niche width 60 cm,
Niche height 82 cm



Included in the price

- 1 egg tray
- 1 ice cube tray

Special accessories

RA430100
Storage container with transparent lid,
anthracite.

Fridge-freezer combination 200 series RT 202

- Interior with solid elements in light satin aluminium
- Height-adjustable safety glass shelf with aluminium profile
- Warm white and glare-free LED light
- Drawer with solid aluminium handle, close to 0 °C
- Cushioned door closing system allowing a soft and controlled door closure
- Total volume 110 litres

Handling

LED electronic with touch control.

Technical features

Cushioned door closing system from 20° door opening angle, integrated in door hinge.
Open-door alarm.
Holiday mode.
Rest mode.

Selected digital services

(Home Connect)
Remote control and monitoring.
Remote diagnostics.

Please read additional information on Home Connect on page 411.

Cooling

Fast cooling.
Temperature adjustable from +2 °C to +6 °C.
1 height-adjustable safety glass shelf with aluminium profile.
1 drawer with solid aluminium handle, close to 0 °C, ideal for meat, fish and poultry.
1 bottom compartment with sliding glass lid.
1 large aluminium door rack for bottles, extra deep.
1 height-adjustable aluminium door rack.
1 adjustable door rack, small.
Warm white interior lighting (3500 K) with integrated glare-free LED side light.
Total volume of all refrigerator compartments: 93 litres.

Freezing

Storage temperature -18 °C and lower.
4-star freezer compartment.
Freezing capacity 3 kg/24 h.
Storage time after a malfunction 9 h.
Volume 17 litres.

Consumption data

Energy efficiency class D at a range of energy efficiency classes from A to G.
Energy consumption 119 kWh/year.
Noise level: 35 dB (A) re 1 pW.

Planning notes

Flat hinge.
Door hinge right, reversible.
Door opening angle of 115°, fixable at 90°.
Max. door panel weight 12 kg.
Height-adjustable feet.
The enclosed ventilation grille must be used.
The mains socket needs to be planned outside the built-in niche.

Please read additional planning notes on page 349.

Connection

Total connected load 0.090 kW.
Connecting cable 2.3 m with plug.

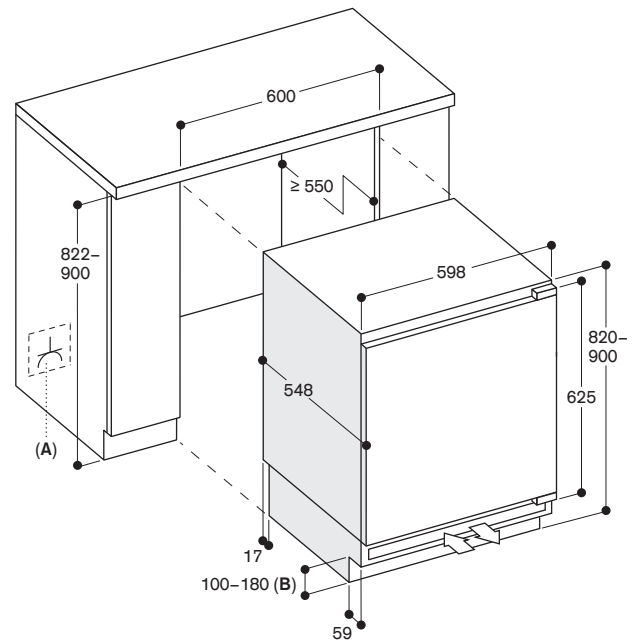

- A:** Socket
B: Base height:
- 100 mm when niche height is 822 mm
- 180 mm when niche height is 900 mm

Measurements in mm

**RC 202 180**

Fully integrated, under-counter
Niche width 60 cm,
Niche height 82 cm

**Included in the price**

1 egg tray

Special accessories

RA 430 100

Storage container with transparent lid,
anthracite.

Refrigerator 200 series**RC 202**

- Interior with solid elements in light satin aluminium
- Height-adjustable safety glass shelves with aluminium profile
- Warm white and glare-free LED light
- Drawer with solid aluminium handle, close to 0 °C
- Cushioned door closing system allowing a soft and controlled door closure
- Total volume: 134 litres

Handling

LED electronic with touch control.

Technical features

Cushioned door closing system from 20° door opening angle, integrated in door hinge.
Open-door alarm.
Holiday mode.
Rest mode.

Selected digital services (Home Connect)

Remote control and monitoring.
Remote diagnostics.

Please read additional information on Home Connect on page 411.

Cooling

Fast cooling.
Temperature adjustable from +2 °C to +6 °C.
2 height-adjustable safety glass shelves with aluminium profile.
1 drawer with solid aluminium handle, close to 0 °C, ideal for meat, fish and poultry.
1 bottom compartment with sliding glass lid.
1 large aluminium door rack for bottles, extra deep.
1 height-adjustable aluminium door rack.
1 adjustable door rack, small.
Warm white interior lighting (3500 K) with integrated glare-free LED side light.

Consumption data

Energy efficiency class E at a range of energy efficiency classes from A to G.
Energy consumption 93 kWh/year.
Noise level: 35 dB (A) re 1 pW.

Planning notes

Flat hinge.
Door hinge right, reversible.
Door opening angle of 115°, fixable at 90°.
Max. door panel weight 12 kg.
Height-adjustable feet.
The enclosed ventilation grille must be used.
The mains socket needs to be planned outside the built-in niche.

Please read additional planning notes on page 349.

Connection

Total connected load 0.090 kW.
Connecting cable 2.3 m with plug.

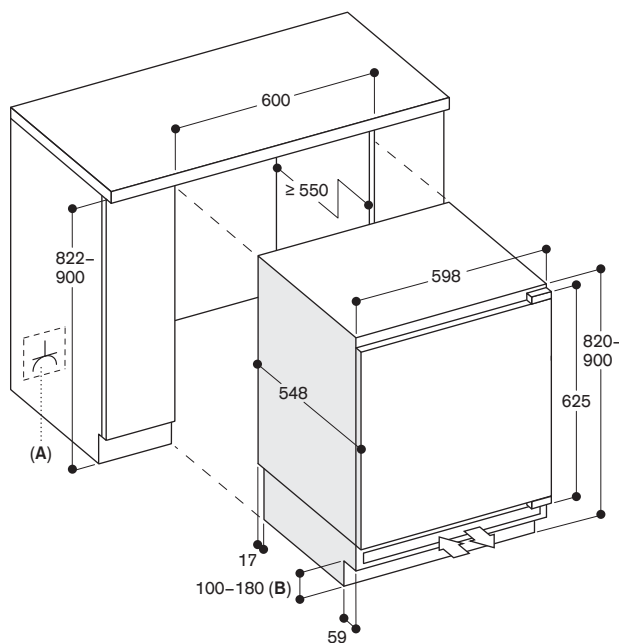

A: Socket

B: Base height:

- 100 mm when niche height is 822 mm
- 180 mm when niche height is 900 mm

Measurements in mm



RF 202 180

Fully integrated, under-counter
Niche width 60 cm,
Niche height 82 cm



Included in the price

1 ice cube tray

Freezer 200 series

RF 202

- Interior with solid elements in light satin aluminium
- Drawers with solid aluminium handles
- Cushioned door closing system allowing a soft and controlled door closure
- Total volume: 85 litres

Handling

LED electronic with touch control.

Technical features

Automatic defrosting.

Cushioned door closing system from 20° door opening angle, integrated in door hinge.

Open-door and malfunction alarm.

Holiday mode.

Rest mode.

Selected digital services

(Home Connect)

Remote control and monitoring.

Remote diagnostics.

Please read additional information on Home Connect on page 411.

Freezing

No-frost technology with fast freezing.

Temperature adjustable

from -24 °C to -18 °C.

4-star freezer compartment.

Freezing capacity 8 kg /24 h.

Storage time after a malfunction 9 h.

Consumption data

Energy efficiency class E at a range of

energy efficiency classes from A to G.

Energy consumption 189 kWh/year.

Noise level: 35 dB (A) re 1 pW.

Planning notes

Flat hinge.

Door hinge right, reversible.

Door opening angle of 115°, fixable at 90°.

Max. door panel weight 12 kg.

Height-adjustable feet.

The enclosed ventilation grille must be used.

The mains socket needs to be planned outside the built-in niche.

Please read additional planning notes on page 349.

Connection

Total connected load 0.090 kW.

Connecting cable 2.3 m with plug.

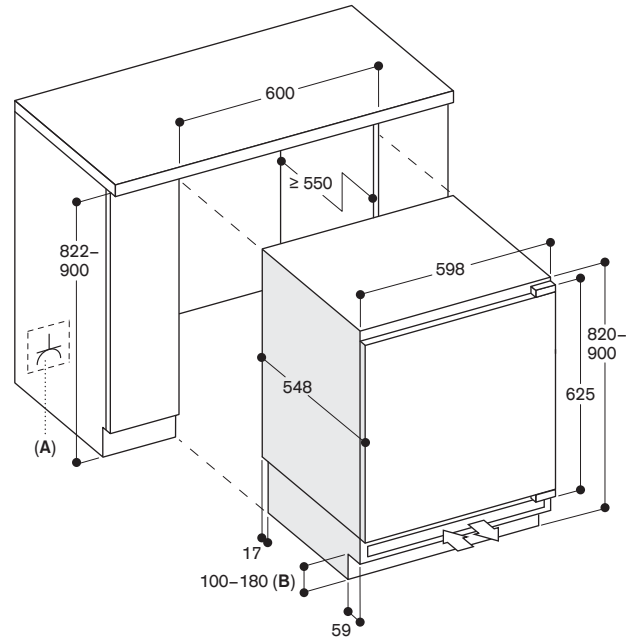

A: Socket

B: Base height:

- 100 mm when niche height is 822 mm
- 180 mm when niche height is 900 mm

Measurements in mm

Location

The appliance should be installed in a dry, well ventilated room. The location of the appliance should not be subject to direct sunlight or near a source of heat, such as an oven, a cooker or a radiator, etc.

If installation next to a heat source is unavoidable, observe the following minimum distances from the heat source:

- 3 cm to electric or gas ovens,
- 3 cm to electric or gas cooker,
- 30 cm to an oil-fired or solid-fuel cooker.

Side-by-side installation

Vario 200 and 200 series cooling appliances can be installed side by side in the following combinations, in their own kitchen units:

- RW + RW
- RC + RF (no other appliance next to RC model)
- RW + RF (no other appliance next to RW model, except RW)

For all other combinations, a minimum clearance of 150 mm must be observed between appliances.

Clearance to adjacent furniture depending on the furniture panel thickness and radii

The panel thickness of customer-specific doors can be between 19 mm and 22 mm.

Recommended gap dimensions for flat hinges

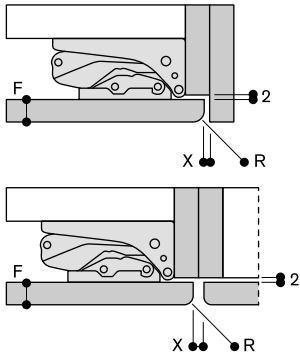

F	R	X
16-19	0-3	2.5
20	0-1	3
	2-3	2.5
21	0-1	3
	2-3	2.5
22	0	4
	1	3.5
	2-3	3

F = Furniture panel thickness
R = Radius
X = Gap dimension

The gap dimensions recommended in the table must be adhered in order to ensure that the appliance door does not collide with anything when it is opened, and to avoid causing damage to furniture panels.

measurements in mm

Door panels

Maximum permissible door panel weight

Recess height	Number of doors	Max. permissible door panel weight
178 cm, Vario 200, 200 series	1	22 kg
178 cm, Vario 200, 200 series	2	19 kg each
178 cm, Vario 200, 200 series + RA 260 000	1	27 kg
178 cm, Vario 200, 200 series + RA 260 000	2	24 kg each
82 cm, 200 series	1	12 kg
178 cm, 123 cm, 200 series wine	1	20 kg

If the maximum permissible weight is exceeded, this may damage or impair the function of the hinge.

Base area

Important!

Poor ventilation leads to damage of the appliance!
The appliance air inlet opening in the base area of the fitted kitchen must not be covered under any circumstances.
A cross-section of at least 200 cm² must be provided for the air inlet opening.

Dimensions of the special accessories – door panel frames.

The following diagrams show the basic dimensions of the special accessories door front frames for RW 282 and RW 222.

The dimensions of the doors shown are designed for the following basic specifications:

- Panel thickness: 19 mm
- Gap: 3 mm

These specifications provide you with a good starting point for a variety of kitchen designs.

Important!

The following diagrams are not a substitute for detailed designs. Compliance with specified requirements relating to kitchen design is essential.

Recess height 178 cm

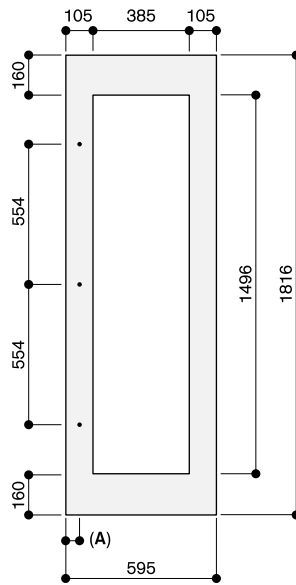

Recess height 123 cm

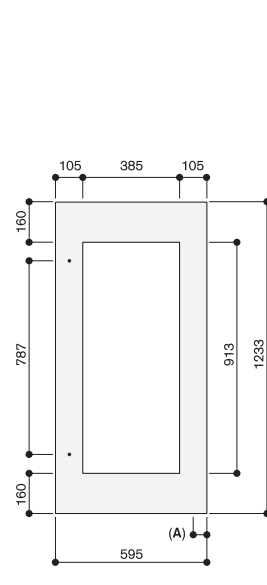

A: 52.5

The door panel thickness is 19 mm.
The maximum door panel dimensions are based on a clearance of 3 mm, based on a single recess.

measurements in mm

Ventilation options

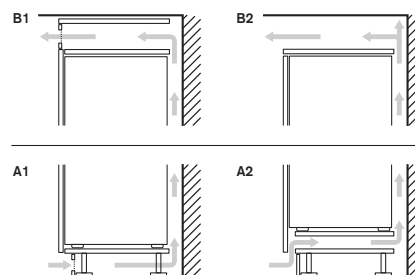
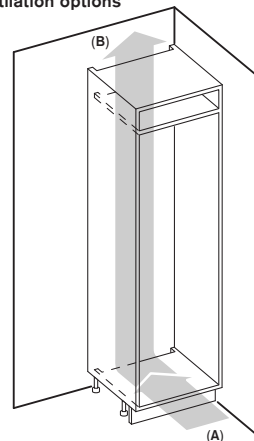

A: Air inlet ≥ 200 cm²; ventilation options A1 or A2

B: Air outlet ≥ 200 cm²; ventilation options B1 or B2



RW 466 365

Fully integrated, with glass door
Niche width 61 cm,
Niche height 213.4 cm



RW 466 305

Fully integrated, with solid door
Niche width 61 cm,
Niche height 213.4 cm



Included in the price

1 Accessory for side-by-side
installation

Installation accessories

RA 420 010

Door lock for RW 414,
RW 464 and RW 466.

RA 421 610

Stainless steel door panel with handle
For 61 cm wide appliances, panel
thickness 19 mm.

RA 421 611

Stainless steel door panel frame with
handle
For 61 cm wide appliances, left-hinged,
panel thickness 19 mm.

RA 421 612

Stainless steel door panel frame with
handle
For 61 cm wide appliances,
right-hinged, panel thickness 19 mm.

RA 423 140

Side trims, long.

RA 425 110

Handle bar, stainless steel, long
With 3 mounts, length 1131 mm,
height 49 mm, drilling distance
between each mount 554 mm.

RA 428 610

Stainless steel door panel, handleless
For 61 cm wide appliances, panel
thickness 19 mm.

RA 428 611

Stainless steel door panel frame,
handleless
For 61 cm wide appliances, panel
thickness 19 mm.

Vario wine climate cabinet 400 series

RW 466

- 3 independently controllable climate zones
- Consistent temperatures with exact control from +5 °C to +20 °C
- Humidity control
- Stainless steel interior
- Fully extendable bottle trays in oak wood and solid aluminium in anthracite
- Bottle trays with hidden telescopic rails
- Warm white and glare-free LED light spots
- 5 preset lighting scenarios, selectable via TFT display
- Opening assist for door with two options:
 1. Push-to-open function for integration into handleless furniture front
 2. Pull-to-open function to facilitate opening the door using a handle
- Low-vibration operation
- TFT touch display
- Number of standard wine bottles: 99

Handling

TFT touch display operation.
Clear text display.
Lockable door (with door lock
RA 420 010).

Technical features

Dynamic cold air distribution.
Automatic defrosting with defrost water evaporation.
Cushioned door closing system.
Activated charcoal air filter.
UV-protection.
Rest mode certified by Star-K.
When rest mode is active, the appliance can only be opened using a handle.
Open-door and malfunction alarm.

Selected digital services (Home Connect)

Remote control and monitoring.
Remote diagnostics.
Light scenarios.

Please read additional information on Home Connect on page 411.

Features

Capacity 99 bottles
(based on 0.75 l standard bottles).
12 bottle trays,
- 9 fully extendable trays
- 3 suitable for storage of Magnum bottles.
Flexible interior configuration possible by adding or removing fully extendable bottle trays.
Storage of up to 12 Magnum bottles with standard tray configuration (12 bottle trays).
Space for max. 12 bottle trays.
2 brilliant LED light spots with warm white, glare-free light (3500 K) in each climate zone.
5 different lighting scenarios can be selected for individual wine presentation.
Total volume 370 litres.

Consumption data

Energy efficiency class G/F at a range of energy efficiency classes from A to G.
Energy consumption 155/129 kWh/year.
Noise level 42 dB (A) re 1 pW.

RA 460 013

Additional side heating element 230 V.
Required if appliances are installed with a distance greater than 16 mm and less than 160 mm next to each other and for all built-in situations in a very humid environment. Not required if appliances are installed more than 160 mm apart from each other.

RA 460 020

Connecting element for vertically split appliance fronts (for a flush front).

RA 464 611

Ventilation grille stainless steel
For 61 cm wide appliances.

Special accessories

RA 430 000

Screw hole cover set. 8 pieces.

RA 491 661

Fully extendable bottle trays with hidden telescopic rails in oak wood and solid aluminium in anthracite
For 61 cm wide appliances.

RA 492 660

Removable shelf with oak wood frame
Suitable for decanters and open bottles.
For 61 cm wide appliances.

RA 493 060

Presenter in oak wood and aluminium in anthracite for single bottle display
1 piece.

RA 498 640

Bottle support in oak wood for convenient storage of bottles on the division plate.
For 61 cm wide appliances.

Planning notes

Flat hinge.
Door hinge right, reversible.
Door opening angle of 115°, fixable at 90°.
Max. door panel weight 73 kg.
The mains socket needs to be planned outside the built-in niche.
No transport/operation above 2000 m sea level.

Please read additional planning notes on page 328 – 335.

Connection

Total connected load 0.300 kW.
Connecting cable 3.0 m, pluggable.

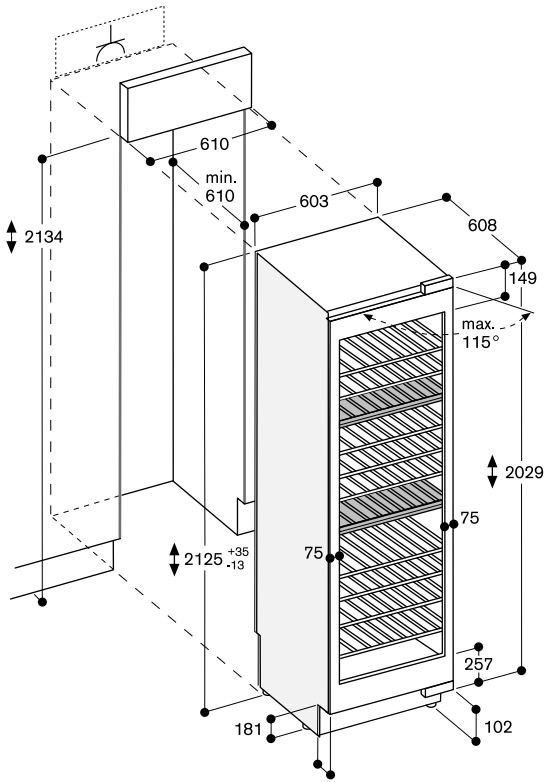

The maximum door panel dimensions are based on a clearance of 3 mm.

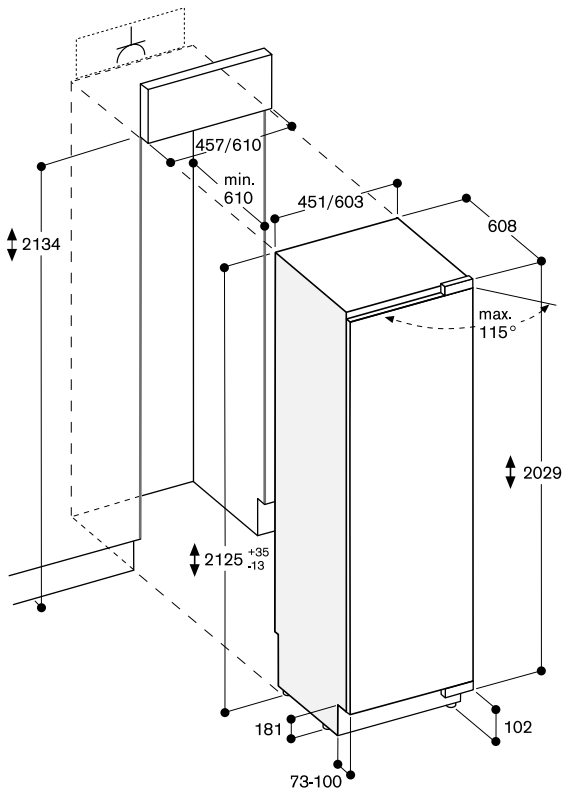

The maximum door panel dimensions are based on a clearance of 3 mm.

Bottle storage

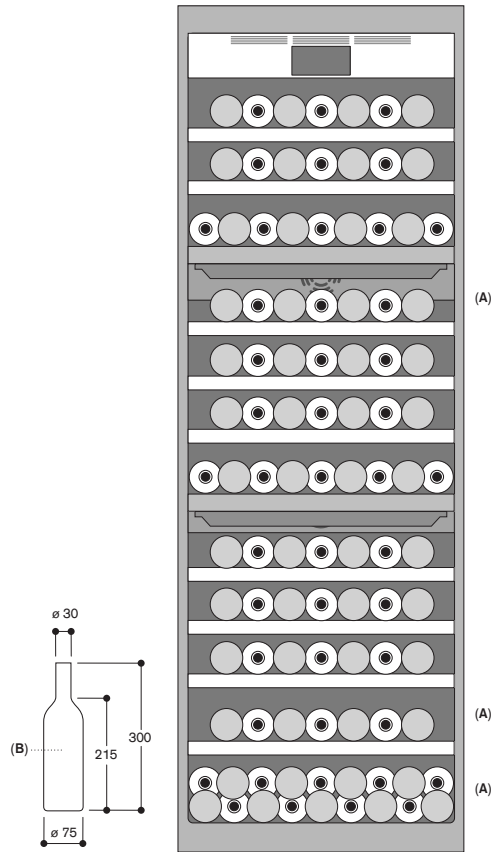

A: Suitable area for storage of magnum bottles in standard tray configuration
 B: 0.75 litres

Measurements in mm



RW 414 365

Fully integrated, with glass door
Niche width 45.7 cm,
Niche height 213.4 cm



RW 414 305

Fully integrated, with solid door
Niche width 45.7 cm,
Niche height 213.4 cm



Included in the price

1 Accessory for side-by-side installation

Installation accessories

RA 420 010

Door lock for RW 414,
RW 464 and RW 466.

RA 421 110

Stainless steel door panel with handle
For 45.7 cm wide appliances, panel
thickness 19 mm.

RA 421 111

Stainless steel door panel frame with
handle
For 45.7 cm wide appliances,
left-hinged, panel thickness 19 mm.

RA 421 112

Stainless steel door panel frame with
handle
For 45.7 cm wide appliances,
right-hinged, panel thickness 19 mm.

RA 423 140

Side trims, long.

RA 425 110

Handle bar, stainless steel, long
With 3 mounts, length 1131 mm,
height 49 mm, drilling distance
between each mount 554 mm.

RA 428 110

Stainless steel door panel, handleless
For 45.7 cm wide appliances, panel
thickness 19 mm.

RA 428 111

Stainless steel door panel frame,
handleless
For 45.7 cm wide appliances, panel
thickness 19 mm.

Vario wine climate cabinet 400 series RW 414

- 2 independently controllable climate zones
- Consistent temperatures with exact control from +5 °C to +20 °C
- Humidity control
- Stainless steel interior
- Fully extendable bottle trays in oak wood and solid aluminium in anthracite
- Bottle trays with hidden telescopic rails
- Warm white and glare-free LED light spots
- 5 preset lighting scenarios, selectable via TFT display
- Opening assist for door with two options:
 1. Push-to-open function for integration into handleless furniture front
 2. Pull-to-open function to facilitate opening the door using a handle
- Low-vibration operation
- TFT touch display
- Number of standard wine bottles: 70

Handling

TFT touch display operation.
Clear text display.
Lockable door (with door lock
RA 420 010).

Technical features

Dynamic cold air distribution.
Automatic defrosting with defrost water evaporation.
Cushioned door closing system.
Activated charcoal air filter.
UV-protection.
Rest mode certified by Star-K.
When rest mode is active, the appliance can only be opened using a handle.
Open-door and malfunction alarm.

Selected digital services (Home Connect)

Remote control and monitoring.
Remote diagnostics.
Light scenarios.

Please read additional information on Home Connect on page 411.

Features

Capacity 70 bottles
(based on 0.75 l standard bottles).
12 bottle trays,
- 10 fully extendable trays
- 3 suitable for storage of Magnum bottles.
Flexible interior configuration possible by adding or removing fully extendable bottle trays.
Storage of up to 6 Magnum bottles with standard tray configuration (12 bottle trays).
Space for max. 13 bottle trays.
2 brilliant LED light spots with warm white, glare-free light (3500 K) in each climate zone.
5 different lighting scenarios can be selected for individual wine presentation.
Total volume 272 litres.

Consumption data

Energy efficiency class G/F at a range of energy efficiency classes from A to G.
Energy consumption 145/120 kWh/year.
Noise level 42 dB (A) re 1 pW.

RA 460 013

Additional side heating element 230 V.
Required if appliances are installed with a distance greater than 16 mm and less than 160 mm next to each other and for all built-in situations in a very humid environment. Not required if appliances are installed more than 160 mm apart from each other.

RA 460 020

Connecting element for vertically split appliance fronts (for a flush front).

RA 464 111

Ventilation grille stainless steel
For 45.7 cm wide appliances.

Special accessories

RA 430 000

Screw hole cover set. 8 pieces.

RA 491 161

Fully extendable bottle trays with hidden telescopic rails in oak wood and solid aluminium in anthracite
For 45.7 cm wide appliances.

RA 492 160

Removable shelf with oak wood frame
Suitable for decanters and open bottles.
For 45.7 cm wide appliances.

RA 493 060

Presenter in oak wood and aluminium in anthracite for single bottle display
1 piece.

RA 498 140

Bottle support in oak wood for convenient storage of bottles on the division plate.
For 45.7 cm wide appliances.

Planning notes

Flat hinge.
Door hinge right, reversible.
Door opening angle of 115°, fixable at 90°.
Max. door panel weight 76 kg.
The mains socket needs to be planned outside the built-in niche.
No transport/operation above 2000 m sea level.

Please read additional planning notes on page 328 – 335.

Connection

Total connected load 0.300 kW.
Connecting cable 3.0 m, pluggable.

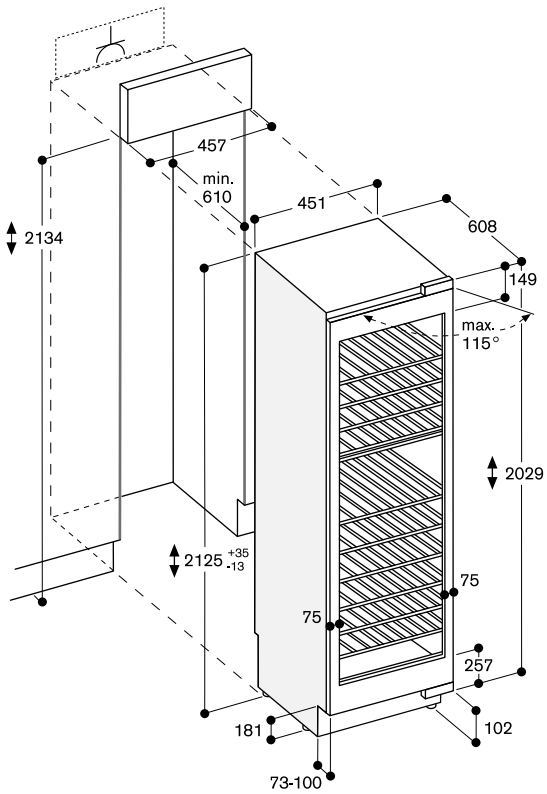

The maximum door panel dimensions are based on a clearance of 3 mm.

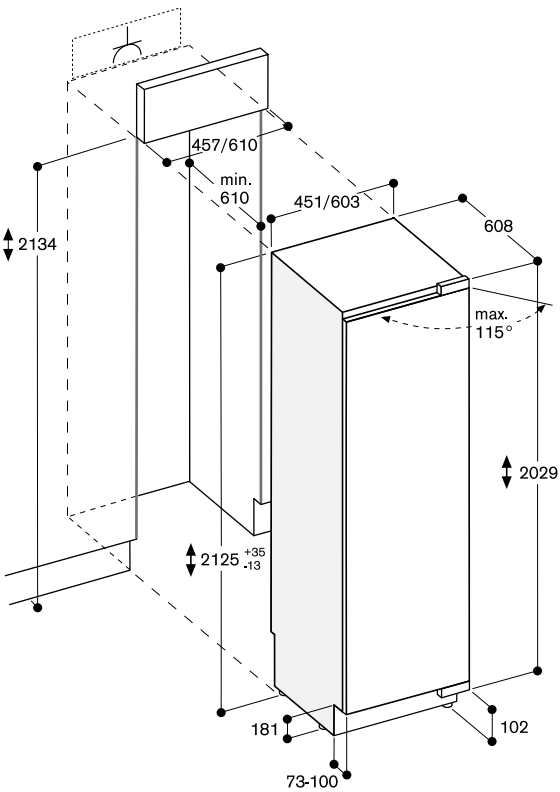

The maximum door panel dimensions are based on a clearance of 3 mm.

Bottle storage

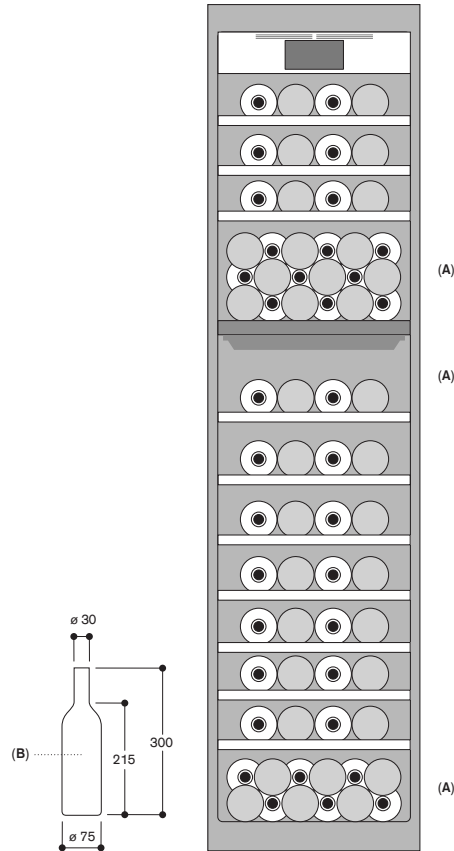

A: Suitable area for storage of magnum bottles in standard tray configuration
B: 0.75 litres

Measurements in mm



RW 282 263

Fully integrated, with glass door
Niche width 56 cm,
Niche height 177.2 cm



Installation accessories

RA 221 311

Stainless steel door panel with handle
for RW 282, panel thickness 19 mm.

RA 425 110

Handle bar, stainless steel, long
With 3 mounts, length 1131 mm,
height 49 mm, drilling distance
between each mount 554 mm.

Special accessories

RA 050 220

Replacement activated charcoal air
filter.

Wine climate cabinet 200 series

RW 282

- 2 independently controllable climate zones
- Consistent temperatures with exact control from +5 °C to +20 °C
- Humidity control
- Extendable bottle trays in beech and aluminium
- Presentation light option
- Low-vibration operation
- Combines with freezer RF287 or RF282 (side-by-side integration)
- Number of standard wine bottles: 80

Handling

Electronic temperature control with digital display.
Touch keys.
Presentation light option in each climate zone, dimmable.
Interior LED lighting (3000 K) with automatic dimming with opening and closing of door.

Technical features

Dynamic cold air distribution.
Automatic defrosting with defrost water evaporation.
Cushioned door closing system integrated in door hinge.
1 activated charcoal air filter for both climate zones.
UV-protection.
Open-door and malfunction alarm.
Child lock.

Features

Capacity 80 bottles
(based on 0.75 l standard bottles).
10 bottle trays, 8 of which are extendable.
Storage of magnum bottles possible.
LED lighting.
Total volume 254 litres.

Consumption data

Energy efficiency class G at a range of energy efficiency classes from A to G.
Energy consumption 162 kWh/year.
Noise level 32 dB (A) re 1 pW.

Planning notes

Flat hinge.
Door hinge right, reversible.
Height-adjustable feet.
Door opening angle of 115°, fixable at 90°.
Max. door panel weight 20 kg.
Door panel thickness min. 16 mm / max. 22 mm.
The mains socket needs to be planned outside the built-in niche.
For a side-by-side installation every appliance must be planned in its own niche.
The wine climate cabinet can be combined with a second wine climate cabinet or a freezer (RF287 or RF282) only. If combining the wine climate cabinet with other cooling appliances (RC, RT, RB), a clearance of min. 150 mm is to be kept between the appliances to avoid condensation.
No transport/operation above 1500 m sea level.

Please read additional planning notes on page 328 – 335.

Connection

Total connected load 0.130 kW.
Connecting cable 2.8 m with plug.

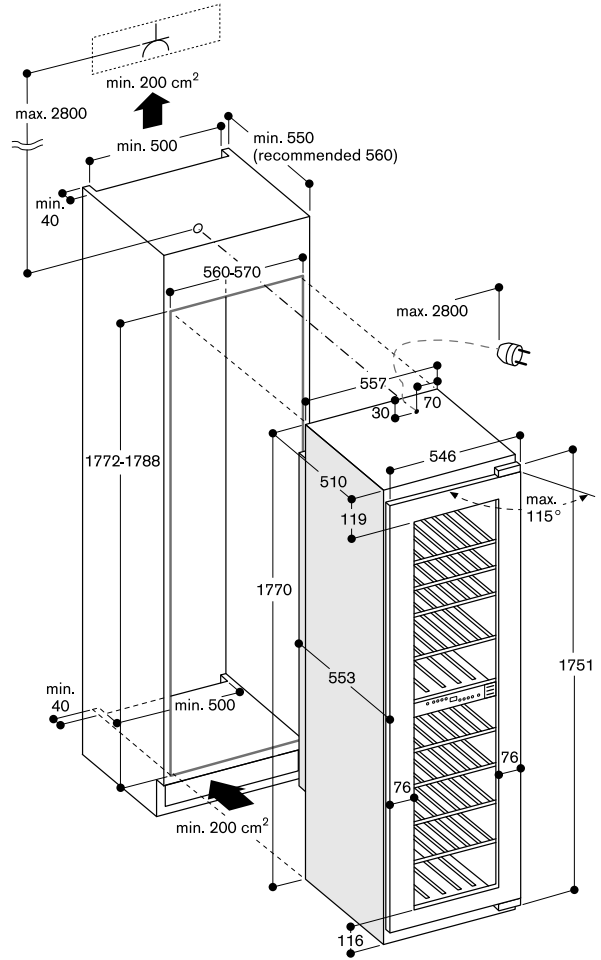

Bottle storage

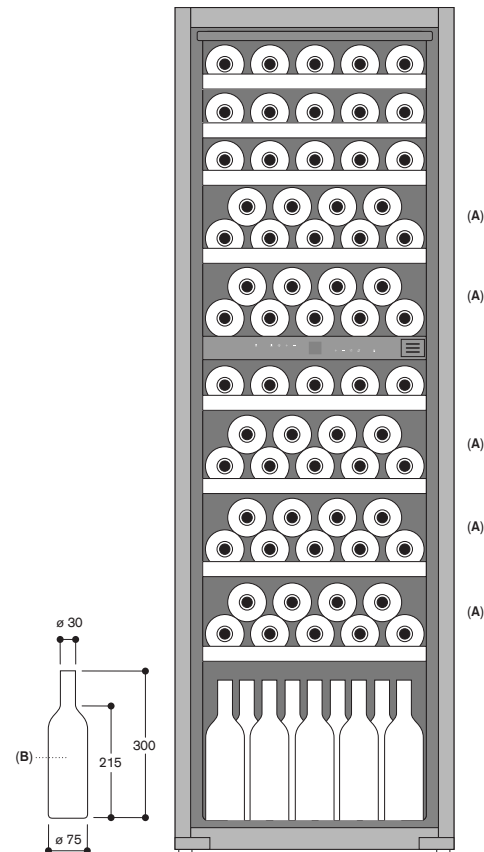

A: Suitable area for storage of magnum bottles
B: 0.75 litres

Measurements in mm

**RW 222 263**

Fully integrated, with glass door
Niche width 56 cm,
Niche height 123 cm

**Installation accessories****RA 221 211**

Stainless steel door panel with handle
For RW 222, panel thickness 19 mm.

RA 425 910

For RVY 497, RB 492 and RW 222,
with 2 mounts, length 810 mm, height
49 mm, drilling distance between the
mounts 787 mm.

Special accessories**RA 050 220**

Replacement activated charcoal air
filter.

Wine climate cabinet 200 series**RW 222**

- 2 independently controllable climate zones
- Consistent temperatures with exact control from +5 °C to +20 °C
- Humidity control
- Extendable bottle trays in beech and aluminium
- Presentation light option
- Low-vibration operation
- Number of standard wine bottles: 48

Handling

Electronic temperature control with digital display.

Touch keys.

Presentation light option in each climate zone, dimmable.

Interior LED lighting (3000 K) with automatic dimming with opening and closing of door.

Technical features

Dynamic cold air distribution.

Automatic defrosting with defrost water evaporation.

Cushioned door closing system integrated in door hinge.

1 activated charcoal air filter for both climate zones.

UV-protection.

Open-door and malfunction alarm.

Child lock.

Features

Capacity 48 bottles
(based on 0.75 l standard bottles).

6 bottle trays, 4 of which are extendable.

Storage of magnum bottles possible.

LED lighting.

Total volume 159 litres.

Consumption data

Energy efficiency class G at a range of energy efficiency classes from A to G.

Energy consumption 151 kWh/year.

Noise level 32 dB (A) re 1 pW.

Planning notes

Flat hinge.

Door hinge right, reversible.

Height-adjustable feet.

Door opening angle of 115°, fixable at 90°.

Max. door panel weight 20 kg.

Door panel thickness

min. 16 mm/max. 22 mm.

The mains socket needs to be planned outside the built-in niche.

For a side-by-side installation every appliance must be planned in its own niche.

When combining the wine climate cabinet with cooling appliances other than a second wine climate cabinet, a clearance of min. 150 mm is to be kept between the appliances to avoid condensation.

No transport/operation above 1500 m sea level.

Connection

Total connected load 0.130 kW.

Connecting cable 2.0 m with plug.

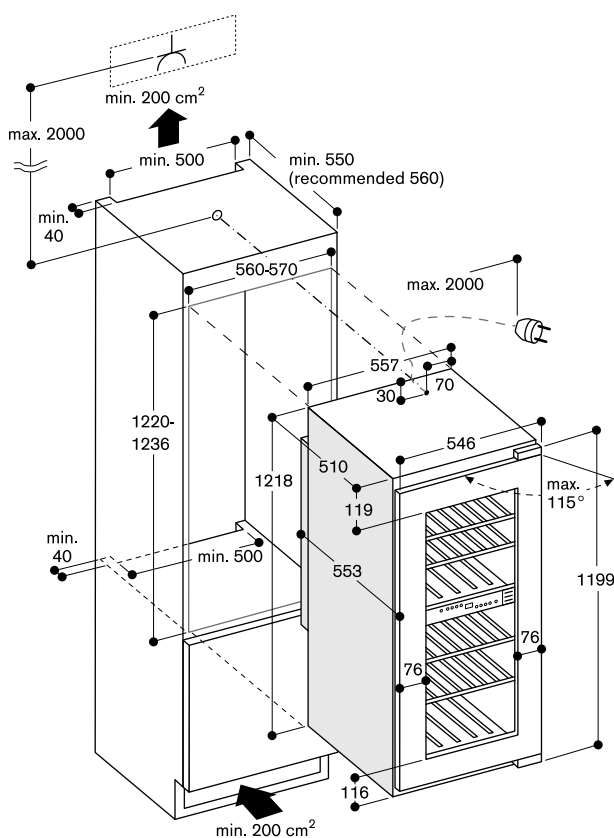
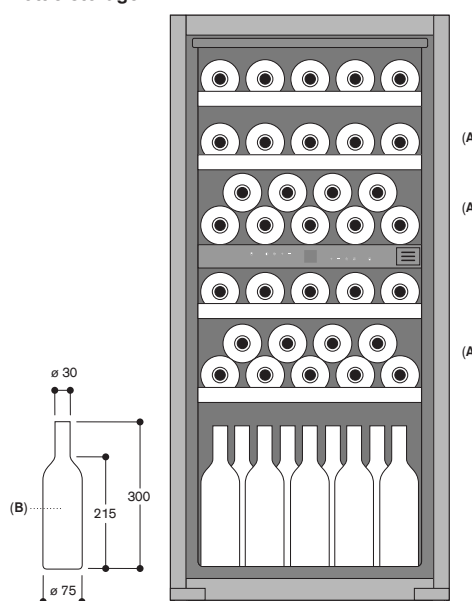
**Bottle storage**

A: Suitable area for storage of magnum bottles

B: 0.75 litres

Measurements in mm



RW 404 264

Under-counter, stainless steel-framed glass door
Niche width 60 cm,
Niche height 82 cm



Special accessories

RA 050 220

Replacement activated charcoal air filter.

RA 097 600

Accessory for side-by-side installation of two under-counter wine climate cabinets

Wine climate cabinet 200 series

RW 404

- 2 independently controllable climate zones
- Consistent temperatures with exact control from +5 °C to +20 °C
- Humidity control
- Extendable bottle trays in beech and aluminium
- LED lighting
- Cushioned door closing system allowing a soft and controlled door closure
- Lockable door
- Number of standard wine bottles: 34
- Side-by-side installation possible with special accessory

Handling

Electronic temperature control with digital display.
Touch keys.
Presentation light option in each climate zone, dimmable.
Interior LED lighting (3000 K) with automatic dimming with opening and closing of door.

Technical features

Dynamic cold air distribution.
Automatic defrosting with defrost water evaporation.
Cushioned door closing system integrated in door hinge.
1 activated charcoal air filter for both climate zones.
UV-protection.
Open-door and malfunction alarm.
Dust filter, dishwasher-safe.

Features

Capacity 34 bottles (based on 0.75 l standard bottles).
5 bottle trays, 3 of which are extendable.
Storage of magnum bottles possible.
LED lighting.
Total volume 94 litres.

Consumption data

Energy efficiency class G at a range of energy efficiency classes from A to G.
Energy consumption 138 kWh/year.
Noise level 34 dB (A) re 1 pW.

Planning notes

Flat hinge.
Door hinge right, reversible.
Height-adjustable feet.
Door opening angle of 115°, fixable at 90°.
For integration next to a side wall a clearance of 150 mm hinge side is necessary.
The mains socket needs to be planned outside the built-in niche.
No transport/operation above 1500 m sea level.

Connection

Total connected load 0.130 kW.
Connecting cable 2.0 m with plug.

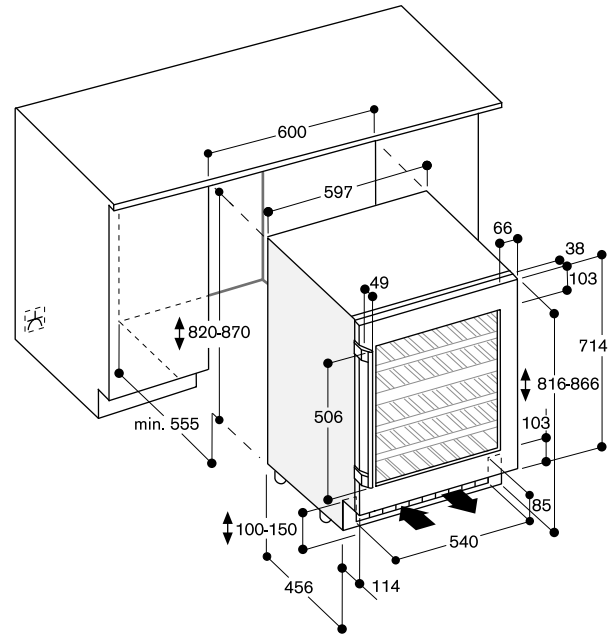

Bottle storage

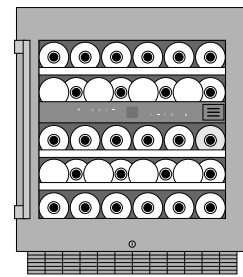
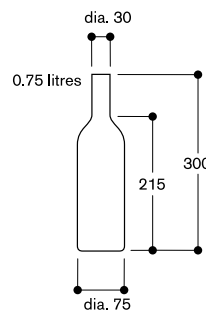

Accessories and special accessories for dark brushed stainless steel fridge-freezer combination RVY 497

RA 430 100
Storage container with transparent lid, anthracite



RVA 438 040
Solid oak wood bottle support with magnetic connector



ACLETHST10
Ethylene absorber
Starter kit.
For placement in a fresh climate drawer.



ACLETHRF10
Ethylene absorber
Refill kit.
For placement in a fresh climate drawer.



RA 450 012
Activated charcoal water filter
For RVY, RY, RB and RF.



RVA 450 220
Activated charcoal air filter
2 pieces.



RVA 421 922
Door panels, dark brushed stainless steel, with handles
For RVY 497, panel thickness 19 mm.



RVA 428 922
Door panels, dark brushed stainless steel, handleless
For RVY 497, panel thickness 19 mm.

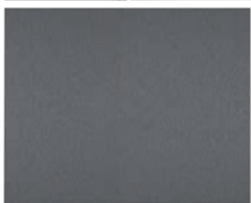

RA 425 110
Handle bar, stainless steel, long
With 3 mounts, length 1.131 mm, height 49 mm, drilling distance between each mount 554 mm.



RA 425 910
For RVY 497, RB 492 and RW 222, with 2 mounts, length 810 mm, height 49 mm, drilling distance between the mounts 787 mm.



RVA 460 000
Accessory for side-by-side installation
For RVY 497.

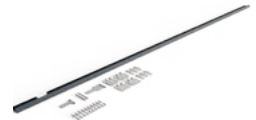

RVA 460 020
Accessory for side-by-side installation, backward compatible
Required if a RVY 497 is installed side-by-side with a RY, RB, RC, RF or RW of the Vario cooling 400 series.



RVA 460 900
Accessory for replacement side-by-side installation in unmodified niche
Required if a RVY 497 (89.4 cm wide) is installed side-by-side into a niche which was formerly housing a combination including a RY 492, RB 492 or RC 492 (90.8 cm wide).

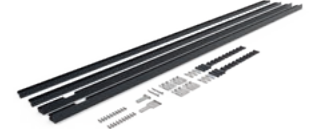

RVA 460 910
Accessory for replacement in single unmodified niche
Required if a RVY 497 (89.4 cm wide) is replacing a RY 492, RB 492 or RC 492 (90.8 cm wide).



RA 460 030
Connecting element for vertically split fronts (for fridge-freezer combination)



RVA 423 141
Side trims, 3 mm
2 pieces.



RA 050 220
Replacement activated charcoal air filter



RA 430 100
Storage container with transparent lid, anthracite



RA 493 060
Presenter in oak wood and aluminium in anthracite for single bottle display 1 piece.



RA 430 000
Screw hole cover set. 8 pieces.



RA 448 220
Ice storage container, small
For installation with a door opening angle of 90° the delivered ice storage container must be exchanged for the small ice storage container. This must be done prior to fixing the door.



RA 492 160
Removable shelf with oak wood frame
Suitable for decanters and open bottles.
For 45.7 cm wide appliances.

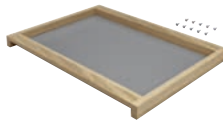

RA 492 660
Removable shelf with oak wood frame
Suitable for decanters and open bottles.
For 61 cm wide appliances.



RA 498 140
Bottle support in oak wood for convenient storage of bottles on the division plate
For 45.7 cm wide appliances.



RA 498 640
Bottle support in oak wood for convenient storage of bottles on the division plate
For 61 cm wide appliances.



RA 238 030
Solid maple bottle support with magnetic connector, oiled



RA 421 110
Stainless steel door panel with handle
For 45.7 cm wide appliances, panel thickness 19 mm.



RA 428 110
Stainless steel door panel, handleless
For 45.7 cm wide appliances, panel thickness 19 mm.



RA 421 111
Stainless steel door panel frame with handle
For 45.7 cm wide appliances, left-hinged, panel thickness 19 mm.



RA 421 112
Stainless steel door panel frame with handle
For 45.7 cm wide appliances, right-hinged, panel thickness 19 mm.



Accessories and special accessories for Vario 400, Vario 200 and 200 series cooling appliances

RA 428 111

Stainless steel door panel frame,
handleless
For 45.7 cm wide appliances, panel
thickness 19 mm.



RA 421 612

Stainless steel door panel frame with
handle
For 61 cm wide appliances,
right-hinged, panel thickness 19 mm.



RA 421 610

Stainless steel door panel with handle
For 61 cm wide appliances,
panel thickness 19 mm.



RA 428 611

Stainless steel door panel frame,
handleless
For 61 cm wide appliances, panel
thickness 19 mm.



RA 428 610

Stainless steel door panel, handleless
For 61 cm wide appliances, panel
thickness 19 mm.

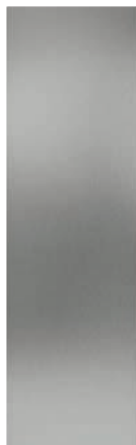

RA 421 710

Stainless steel door panel with handle
For 76.2 cm wide appliances,
panel thickness 19 mm.

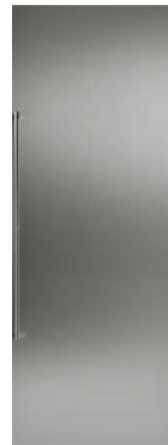

RA 421 611

Stainless steel door panel frame with
handle
For 61 cm wide appliances,
left-hinged, panel thickness 19 mm.



RA 428 710

Stainless steel door panel, handleless
For 76.2 cm wide appliances, panel
thickness 19 mm.



RA 421 911

Stainless steel door panel with handle
For 91.4 cm wide appliances, panel
thickness 19 mm.

**RA 421 910**

Stainless steel door panels with
handles
For RB 492, panel thickness 19 mm.

**RA 428 911**

Stainless steel door panel, handleless
For 91.4 cm wide appliances, panel
thickness 19 mm.

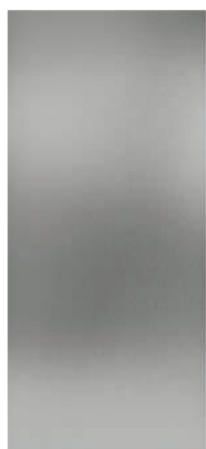
**RA 428 910**

Stainless steel door panels, handleless
For RB 492, panel thickness 19 mm.

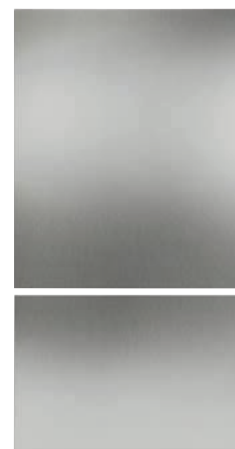
**RA 421 712**

Stainless steel door panel with handle
For RB 472, panel thickness 19 mm.

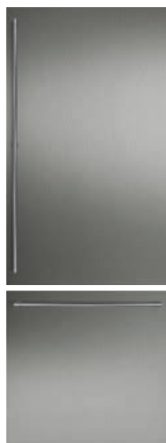
**RA 221 311**

Stainless steel door panel with handle
For RW 282, panel thickness 19 mm.

**RA 428 712**

Stainless steel door panels, handleless
For RB 472, panel thickness 19 mm.

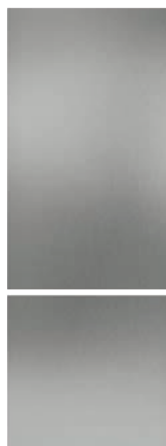
**RA 221 211**

Stainless steel door panel with handle
For RW 222, panel thickness 19 mm.



Accessories and special accessories for Vario 400, Vario 200 and 200 series cooling appliances

RA 425 110

Handle bar, stainless steel, long
With 3 mounts, length 1.131 mm,
height 49 mm, drilling distance
between each mount 554 mm.



RA 425 710

Handle bar, stainless steel, short.
For RB 472 with 2 mounts,
length 658 mm, height 49 mm,
drilling distance between the mounts
637 mm.



RA 425 910

For RVY 497, RB 492 and RW 222,
with 2 mounts, length 810 mm,
height 49 mm, drilling distance
between the mounts 787 mm.



RA 450 012

Activated charcoal water filter
For RVY, RY, RB and RF.



RA 460 000

Accessory for side-by-side installation.
Not required if appliances are installed
more than 160 mm apart from each other.
Included in delivery for RF and RW.



RA 460 013

Additional side heating element 230 V.
Required if appliances are installed
with a distance greater than 16 mm and
less than 160 mm next to each other
and for all built-in situations in a very
humid environment. Not required if
appliances are installed more than
160 mm apart from each other.



RA 460 020

Connecting element for vertically split
appliance fronts (for a flush front)



RA 460 030

Connecting element for vertically split
fronts (for fridge-freezer combination)



RA 464 111

Ventilation grille stainless steel
For 45.7 cm wide appliances.



RA 464 113

Ventilation grille stainless steel
For 45.7 cm wide appliances with
integrated water filter.



RA 464 611

Ventilation grille stainless steel
For 61 cm wide appliances.



RA 464 616

Ventilation grille stainless steel
For 61 cm wide appliances with
integrated water filter.



RA 464 711

Ventilation grille stainless steel
For 76.2 cm wide appliances.



RA 464 714

Ventilation grille stainless steel
For 76.2 cm wide appliances with
integrated water filter.



RA 464 713

Ventilation grille stainless steel
For RB 472.



RA 464 913

Ventilation grille stainless steel
For RB 492.



RA 464 911

Ventilation grille stainless steel
For 91.4 cm wide appliances.



RA 420 010

Door lock for RW 414 and RW 466



RA 097 600

Accessory for side-by-side installation
of two under-counter wine climate
cabinets

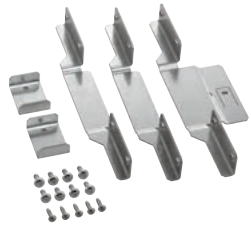

RA 260 000

Heavy duty hinge support
For RC/RF/RT 28* maximum door
weight 27 kg.
For RB 28* maximum door weight 24 kg.
RB 28* requires 2 x RA 260 000.



RA 491 161

Fully extendable bottle trays with hidden telescopic rails in oak wood and solid aluminium in anthracite
For 45.7 cm wide appliances.

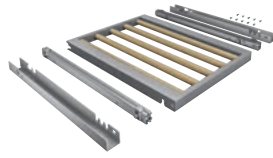
**RA 491 661**

Fully extendable bottle trays with hidden telescopic rails in oak wood and solid aluminium in anthracite
For 61 cm wide appliances.

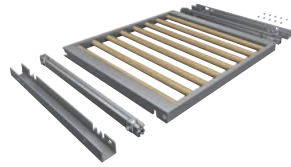
**RA 423 140**

Side trims, long

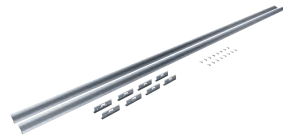
**RA 423 340**

Side trims, 2 pieces, for RB

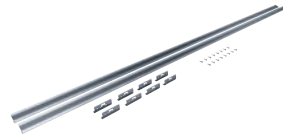

Special accessories for dark brushed stainless steel fridge-freezer combination RVY 497



Appliance type		Fridge-freezer combination
		RVY 497 190
Door panels		
Dark brushed stainless steel door panel with handles, panel thickness 19 mm.		RVA 421 922
Dark brushed stainless steel door panel without handles, panel thickness 19 mm.		RVA 428 922
Handles		
RA 425 110	Handle bar, stainless steel, long. With 3 mounts, length 1.131 mm, drilling distance between each mount 554 mm.	•
RA 425 910	Handle bar, stainless steel, short. For RVY 497 and RB/RY 492, with 2 mounts, length 810 mm, drilling distance between the mounts 787 mm.	•
Miscellaneous		
RA 430 100	Storage container with transparent lid, anthracite	•
RVA 438 040	Solid oak wood bottle support	•
RA 450 012	Activated charcoal water filter	•
RVA 450 220	Activated charcoal air filter	•
ACLETHST10	Ethylene absorber - Starter kit	•
ACLETHRF10	Ethylene absorber - Refill kit	•

Special accessories for Vario cooling 400 series



Appliance type	Fridge-freezer combination	Fridge-freezer combination	Refrigerator	Refrigerator
	RB 492 305	RB 472 305	RC 492 305	RC 472 305
Door panels / door panel frames				
Stainless steel door panel with handles, panel thickness 19 mm.	RA 421 910	RA 421 712	RA 421 911	RA 421 710
Stainless steel door panel without handles, panel thickness 19 mm.	RA 428 910	RA 428 712	RA 428 911	RA 428 710
Stainless steel door panel frame with handle, left-hinged, panel thickness 19 mm.				
Stainless steel door panel frame with handle, right-hinged, panel thickness 19 mm.				
Stainless steel door panel frame without handle, panel thickness 19 mm.				
RA 420 010 Door lock for RW 414 and RW 464				
Ventilation grille				
Stainless steel	RA 464 913	RA 464 713	RA 464 911	RA 464 711
Interior for wine climate cabinet				
Fully extendable bottle trays in oak wood and solid aluminium in anthracite.				
Removable shelf with oak wood frame. Suitable for decanters and open bottles.				
Presenter in oak wood and aluminium in anthracite for single bottle display. 1 piece.				
Bottle support in oak wood for convenient storage of bottles on the division plate.				
RA 430 000 Screw whole cover set. 8 Pieces.				
Handles				
RA 425 110 Handle bar, stainless steel, long. With 3 mounts, length 1.131 mm, height 49 mm, drilling distance between each mount 554 mm.	•	•	•	•
RA 425 710 Handle bar, stainless steel, short. For RB 472 with 2 mounts, length 658 mm, height 49 mm, drilling distance between the mounts 637 mm.		•		
RA 425 910 Handle bar, stainless steel, short. For RVY 497, RB 492 and RW 222, with 2 mounts, length 810 mm, height 49 mm, drilling distance between the mounts 787 mm.	•			
Miscellaneous				
RA 430 100 Storage container with transparent lid, anthracite.	•	•	•	•
RA 448 220 Ice storage container, small. For installation with a door opening angle of 90°				
RA 450 012 Activated charcoal filter for water filter system	•	•		
ET 636 458 Activated charcoal air filter (spare part)	•	•	•	•



Refrigerator	Freezer	Freezer	Freezer	Freezer	Wine climate cabinet	Wine climate cabinet	Wine climate cabinet	Wine climate cabinet
RC 462 305	RF 471 306	RF 461 306	RF 411 306	RF 410 304	RW 466 365	RW 414 365	RW 466 305	RW 414 305
RA 421 610	RA 421 710	RA 421 610	RA 421 110	RA 421 110			RA 421 610	RA 421 110
RA 428 610	RA 428 710	RA 428 610	RA 428 110	RA 428 110			RA 428 610	RA 428 110
					RA 421 611	RA 421 111		
					RA 421 612	RA 421 112		
					RA 428 611	RA 428 111		
					•	•	•	•
RA 464 611	RA 464 714	RA 464 616	RA 464 113	RA 464 111	RA 464 611	RA 464 111	RA 464 611	RA 464 111
					RA 491 661	RA 491 161	RA 491 661	RA 491 161
					RA 492 660	RA 492 160	RA 492 660	RA 492 160
					RA 493 060	RA 493 060	RA 493 060	RA 493 060
					RA 498 640	RA 498 140	RA 498 640	RA 498 140
					•	•	•	•
•	•	•	•	•	•	•	•	•
•	•	•	•					
•	•	•	•		•	•	•	•

Dark brushed stainless steel fridge-freezer combination RVY 497



Appliance type		Fridge-freezer combination
Fully integrated		RVY 497 190
Dimensions		
Appliance dimensions W x H x D	(cm)	89.4 x 212.3 x 60.8
Niche dimensions W x H x D	(cm)	90.0 x 213.4 x 61
Depth including wall clearance	(cm)	61
Weight when empty	(kg)	217.7
Shipping weight	(kg)	238
Maximum load weight	(kg)	583.6
Transport package dimensions W x H x D	(cm)	97.6 x 227 x 76
Type and configuration		
Cooling / freezing		•/•
Fresh climate drawer / Chilled drawer		•/•
Door hinge right / left / reversible		•/•/-
Dark brushed stainless steel door panel		◦
Volume / consumption data		
Total volume	(l)	577
- Volume of cooling	(l)	380
- Volume of freezing	(l)	197
Energy efficiency class		
Daily energy consumption ¹	(kWh/24h)	0.75
Annual energy consumption ¹	(kWh)	275
Noise level	(dB (A) re 1 pW)	39
Noise efficiency class		C
Climate class ²		SN - T
Handling		
TFT touch display		•
Opening assist for doors and freezer drawer		•
Clear text display	(No. of languages)	42
Features		
Ice cubes / Ice and water dispenser with ice cubes / crushed ice / water		•/-/-/-
Cooling compartments with temperature and humidity control	(no.)	2
Temperature / climate zones	(no.)	5
Temperature adjustable to the precise degree		•
No-Frost technology		•
Automatic defrosting: cooling / freezing		•/•
Activated charcoal air filter		2
Dark brushed stainless steel interior		•
Holiday mode		•
Malfunction, visual / audible warning signal		•/•
Door open, visual / audible warning signal or door lock indication		-/•
Digital services (Home Connect) wireless via WiFi. ³		•
Cooling		
Fast cooling		•
Dynamic cold air distribution		•
Levels in the interior	(no.)	3
Containers / drawers in the interior	(no.)	3
Door racks	(no.)	6
Egg racks	(No. of eggs)	18
Freezing		
Fast freezing		•
Freezing capacity	(kg/24h)	10
Storage time after a malfunction	(hrs.)	13
Interior compartments	(no.)	-
Baskets, containers, drawers in the interior	(no.)	3
Door racks	(no.)	-
Ice bucket, ice cube trays	(no.)	1
Activated charcoal filter		◦
Connection		
Total connected load	(kW)	0.200
Water connection inlet		•

• Standard. - Not available. ◦ Special accessory.

¹ Effective consumption depends on the use/location of appliance.

² The appliance is fully functional within the room temperature limits defined in the following climate classes: SN-ST (+10 °C to +38 °C), SNT (+10 °C to +43 °C).

³ The use of the Home Connect functionality depends on the Home Connect services, which are not available in every country.

Vario cooling appliances 400 series



Appliance type		Fridge-freezer combination	Fridge-freezer combination	Refrigerator	Refrigerator
Fully integrated / integrated		RB 492 305	RB 472 305	RC 492 305	RC 472 305
Dimensions					
Appliance dimensions W x H x D	(cm)	90.8 x 212.5 x 60.8	75.6 x 212.5 x 60.8	90.8 x 212.5 x 60.8	75.6 x 212.5 x 60.8
Niche dimensions W x H x D	(cm)	91.4 x 213.4 x 61	76.2 x 213.4 x 61	91.4 x 213.4 x 61	76.2 x 213.4 x 61
Depth including wall clearance	(cm)	61	61	61	61
Weight when empty	(kg)	226	203	205	182
Shipping weight	(kg)	244	219	223	198
Maximum load weight	(kg)	616	433	564	564
Transport package dimensions W x H x D	(cm)	100 x 226 x 75	85 x 226 x 75	100 x 230 x 75	85 x 226 x 75
Type and configuration					
Cooling / freezing / wine		•/•/-	•/•/-	•/-/-	•/-/-
Fresh cooling 0°C / fresh cooling <> 0°C / fresh cooling		-/•/•	-/•/•	•/-/•	•/-/•
Fully integrated / integrated / under-counter / free-standing		•/-/-/-	•/-/-/-	•/-/-/-	•/-/-/-
Door hinge right / left / reversible		•/-/•	•/-/•	•/-/•	•/-/•
Glass door		-	-	-	-
Full panelling / door panelling		-/°	-/°	-/°	-/°
Volume / consumption data					
Total volume	(l)	555	452	579	467
- Total volume all cooling compartments	(l)	389	316	-	-
- Volume of cooling	(l)	-	-	494	398
- Volume of fresh cooling 0°C / Fresh cooling <> 0°C	(l)	-	-	85	69
- Volume of freezing	(l)	166	136	-	-
Number of standard wine bottles (0.75 litres)	(no.)	-	-	-	-
Energy efficiency class					
Daily energy consumption ¹	(kWh/24h)	0.893	0.809	0.498	0.454
Annual energy consumption ¹	(kWh)	326	295	182	166
Noise level	(dB (A) re 1 pW)	42	42	40	40
Noise efficiency class		D	D	C	C
Climate class ²		SN - T	SN - T	SN - T	SN - T
Handling					
TFT touch display		•	•	•	•
Opening assist for doors and freezer drawer		•	•	•	•
Clear text display	(No. of languages)	52	52	52	52
Features					
Ice cubes / Ice and water dispenser with ice cubes / crushed ice / water		•/-/-/-	•/-/-/-	-/-/-/-	-/-/-/-
Fresh cooling zones with temperature control	(no.)	•	•	•	•
Fresh cooling zones with humidity control	(no.)	•	•	•	•
Temperature / climate zones	(no.)	4	4	3	3
Temperature display internal / external		•/-	•/-	•/-	•/-
Temperature adjustable to the precise degree		•	•	•	•
No-Frost technology		•	•	•	•
Automatic defrosting: cooling / fresh cooling / freezing		•/•/•	•/•/•	•/•/-	•/•/-
Presentation light	(no.)	-	-	-	-
Lock		-	-	-	-
Humidity control		-	-	-	-
Activated charcoal air filter		•	•	•	•
Low-vibration operation		-	-	-	-
UV-protection		-	-	-	-
Stainless steel interior		•	•	•	•
Holiday mode		•	•	-	-
Malfunction, visual / audible warning signal		•/•	•/•	•/•	•/•
Door open, visual / audible warning signal or door lock indication		-/•	-/•	-/•	-/•
Digital services (Home Connect) wireless via WiFi. ³		•	•	•	•
Cooling / fresh cooling					
Fast cooling		•	•	•	•
Dynamic cold air distribution		•	•	•	•
Levels in the interior	(No.)	3	3	4	4
Containers / drawers in the interior	(No.)	2	2	3	3
Door racks	(No.)	3	3	3	4
Egg racks	(No. of eggs)	18	18	18	18
Wine					
Max. levels in the interior		-	-	-	-
Bottle tray fully extendable / extendable		-	-	-	-
Shelf fully extendable / extendable / removable		-	-	-	-
Storage of Magnum bottles possible		-	-	-	-
Suitable for decanters, open bottles and humidors		-	-	-	-
Freezing					
Fast freezing		•	•	-	-
Freezing capacity	(kg/24h)	14	14	-	-
Storage time after a malfunction	(hrs.)	13	13	-	-
Interior compartments	(no.)	-	-	-	-
Baskets, containers, drawers in the interior	(no.)	2	2	-	-
Door racks	(no.)	-	-	-	-
Ice bucket, ice cube trays	(no.)	1	1	-	-
Activated charcoal filter for water filter system		°	°	-	-
Connection					
Total connected load	(kW)	0.300	0.300	0.300	0.300
Water connection inlet		•	•	-	-

• Standard. - Not available. ° Special accessory.

¹ Effective consumption depends on the use/location of appliance.

² The appliance is fully functional within the room temperature limits defined in the following climate classes: SN-ST (+10 °C to +38 °C), SNT (+10 °C to +43 °C).

³ The use of the Home Connect functionality depends on the Home Connect services, which are not available in every country.



Refrigerator	Freezer	Freezer	Freezer	Freezer	Wine climate cabinet	Wine climate cabinet	Wine climate cabinet	Wine climate cabinet
RC 462 305	RF 471 306	RF 461 306	RF 411 306	RF 410 304	RW 466 365	RW 414 365	RW 466 305	RW 414 305
60.3 x 212.5 x 60.8	75.6 x 212.5 x 60.8	60.3 x 212.5 x 60.8	45.1 x 212.5 x 60.8	45.1 x 212.5 x 60.8	60.3 x 212.5 x 60.8	45.1 x 212.5 x 60.8	60.3 x 212.5 x 60.8	45.1 x 212.5 x 60.8
61 x 213.4 x 61	76.2 x 213.4 x 61	61 x 213.4 x 61	45.7 x 213.4 x 61	45.7 x 213.4 x 61	61 x 213.4 x 61	45.7 x 213.4 x 61	61 x 213.4 x 61	45.7 x 213.4 x 61
61	61	61	61	61	61	61	61	61
163	182	158	130	135	165	140	159	139
178	199	173	143	148	179	152	173	152
555	483	401	300	300	571	377	571	377
70 x 226 x 74	85 x 226 x 75	70 x 226 x 75	55 x 226 x 75	55 x 226 x 75	70 x 226 x 75	55 x 226 x 75	70 x 226 x 75	55 x 226 x 75
•/•/•	-/•/-	-/•/-	-/•/-	-/•/-	-/•/•	-/•/•	-/•/•	-/•/•
•/•/•	-/•/-	-/•/-	-/•/-	-/•/-	-/•/•	-/•/•	-/•/•	-/•/•
•/•/•/•	•/•/•/•	•/•/•/•	•/•/•/•	•/•/•/•	•/•/•/•	•/•/•/•	•/•/•/•	•/•/•/•
•/•/•	-/•/•	-/•/•	-/•/•	-/•/•	•/•/•	•/•/•	•/•/•	•/•/•
-	-	-	-	-	•	•	-	-
-/°	-/°	-/°	-/°	-/°	-/°	-/°	-/°	-/°
357	445	344	240	240	370	272	370	272
-	-	-	-	-	-	-	-	-
305	-	-	-	-	-	-	-	-
52	-	-	-	-	-	-	-	-
-	445	344	240	240	-	-	-	-
-	-	-	-	-	99	70	99	70
0.410	0.791	0.700	0.607	0.607	0.425	0.396	0.354	0.330
150	321	284	246	246	155	145	129	120
40	42	42	42	42	42	42	42	42
C	D	D	D	D	D	D	D	D
SN - T	SN - T	SN - T	SN - T	SN - T	SN - T	SN - T	SN - T	SN - T
•	•	•	•	•	•	•	•	•
•	•	•	•	•	•	•	•	•
52	52	52	52	52	52	52	52	52
-/•/•/•	•/•/•/•	•/•/•/•	•/•/•/•	-/•/•/•	-/•/•/•	-/•/•/•	-/•/•/•	-/•/•/•
•	-	-	-	-	-	-	-	-
•	-	-	-	-	-	-	-	-
3	1	1	1	1	3	2	3	2
•/•	•/•	•/•	•/•	•/•	•/•	•/•	•/•	•/•
•	•	•	•	•	•	•	•	•
•	•	•	•	•	•	•	•	•
•/•/•	-/•/•	-/•/•	-/•/•	-/•/•	•/•/•	•/•/•	•/•/•	•/•/•
-	-	-	-	-	5	5	5	5
-	-	-	-	-	°	°	°	°
-	-	-	-	-	•	•	•	•
-	-	-	-	-	•	•	•	•
-	-	-	-	-	•	•	•	•
-	-	-	-	-	•	•	•	•
-	-	-	-	-	•	•	•	•
•/•	•/•	•/•	•/•	•/•	•/•	•/•	•/•	•/•
-/•	-/•	-/•	-/•	-/•	-/•	-/•	-/•	-/•
•	•	•	•	•	•	•	•	•
•	-	-	-	-	-	-	-	-
•	-	-	-	-	-	-	-	-
4	-	-	-	-	-	-	-	-
3	-	-	-	-	-	-	-	-
4	-	-	-	-	-	-	-	-
18	-	-	-	-	-	-	-	-
-	-	-	-	-	12	13	12	13
-	-	-	-	-	•	•	•	•
-	-	-	-	-	°	°	°	°
-	-	-	-	-	•	•	•	•
-	-	-	-	-	°	°	°	°
-	•	•	•	•	-	-	-	-
-	23	19	16	16	-	-	-	-
-	10	7	6	6	-	-	-	-
-	5	5	5	5	-	-	-	-
-	2	2	2	2	-	-	-	-
-	4	4	4	4	-	-	-	-
-	1	1	1	-	-	-	-	-
-	°	°	°	-	-	-	-	-
0.300	0.300	0.300	0.300	0.300	0.300	0.300	0.300	0.300
-	•	•	•	-	-	-	-	-

EB 333
 Ovens 400 series
 Ovens 200 series
 Vario cooktops
 Cooktops
 Extractors
 Cooling appliances
 Dishwashers | Washing machine
 Energy Label | Home Connect | Accessories

Wine climate cabinets



Appliance type		Wine climate cabinet	Wine climate cabinet	Wine climate cabinet
Fully integrated / integrated		RW 282 263	RW 222 263	
Stainless steel glass door				RW 404 264
Dimensions				
Appliance dimensions W x H x D	(cm)	55.7 x 177 x 55.3	55.7 x 121.8 x 55.3	59.7 x 82-87 x 57
Niche dimensions W x H x D	(cm)	56 x 177.2 x 55	56 x 122 x 55	60 x 82-87 x 58
Depth including wall clearance	(cm)	55	55	58
Weight when empty	(kg)	89	64	52
Shipping weight	(kg)	101	74	56
Transport package dimensions W x H x D	(cm)	64 x 190 x 64	64 x 139 x 64	66 x 87 x 69
Type and configuration				
Cooling / freezing / wine		-/-*	-/-*	-/-*
Fresh cooling 0°C / fresh cooling <> 0°C / fresh cooling		-/-/-	-/-/-	-/-/-
Fully integrated / integrated / under-counter / free-standing		*/-/-/-	*/-/-/-	-/-/*/-
Door hinge right / left / reversible		*/-*	*/-*	*/-*
Full panelling / door panelling		-/-	-/-	-/-
Volume / consumption data				
Total volume	(l)	254	159	94
Number of standard wine bottles (0.75 litres)	(no.)	80	48	34
Energy efficiency class				
Daily energy consumption ¹	(kWh/24h)	0.444	0.414	0.378
Annual energy consumption ¹	(kWh)	162	151	138
Noise level	(dB (A) re 1 pW)	32	32	34
Noise efficiency class		B	B	B
Climate class ²		SN-ST	SN-ST	SN - ST
Features				
Temperature / climate zones	(No.)	2	2	2
Temperature display internal / external		*/-	*/-	*/-
Temperature adjustable to the precise degree		•	•	•
Automatic defrosting: cooling / fresh cooling / freezing		*/-/-	*/-/-	*/-/-
Presentation light		•	•	•
Lock		-	-	•
Humidity control		•	•	•
Activated charcoal air filter		•	•	•
Low-vibration operation		•	•	•
UV-protection		•	•	•
Malfunction, visual / audible warning signal		*/-	*/-	*/-
Door open, visual / audible warning signal or door lock indication		*/*	*/*	*/*
Digital services (Home Connect) wireless via WiFi. ³		-	-	-
Cooling / fresh cooling				
Dynamic cold air distribution		•	•	•
Wine				
Max. levels in the interior		10	6	5
Bottle tray fully extendable / extendable		-/*	-/*	-/*
Shelf fully extendable / extendable		-/-	-/-	-/-
Storage of Magnum bottles possible		•	•	•
Suitable for decanters, open bottles and humidors		-	-	-
Connection				
Total connected load	(kW)	0.13	0.13	0.13
Water connection inlet		-	-	-

• Standard. - Not available.

¹ Effective consumption depends on the use/location of appliance.

² The appliance is fully functional within the room temperature limits defined in the following climate classes: SN-ST (+10 °C to +38 °C), SNT (+10 °C to +43 °C).

³ The use of the Home Connect functionality depends on the Home Connect services, which are not available in every country.



Appliance type		Fridge-freezer combination	Fridge-freezer combination	Refrigerator	Freezer
Fully integrated / integrated		RB 289 300	RT 289 370	RC 289 370	RF 287 370
Dimensions					
Appliance dimensions W x H x D	(cm)	55.8 x 177.2 x 54.5	55.8 x 177.2 x 54.5	55.8 x 177.2 x 54.5	55.8 x 177.2 x 54.5
Niche dimensions W x H x D	(cm)	56 x 177.5 x 55	56 x 177.5 x 55	56 x 177.5 x 55	56 x 177.5 x 55
Depth including wall clearance	(cm)	55	55	55	55
Weight when empty	(kg)	76	71	72	64
Shipping weight	(kg)	81	76	77	70
Transport package dimensions W x H x D	(cm)	62 x 184 x 64	62 x 184 x 64	62 x 184 x 64	62 x 184 x 64
Type and configuration					
Cooling / freezing / wine		•/•/-	•/•/-	•/-/-	-/•/-
Fresh cooling 0°C / fresh cooling <> 0°C / fresh cooling		-/•/-	-/•/-	-/•/-	-/-/-
Fully integrated / integrated / under-counter / free-standing		•/-/-/-	•/-/-/-	•/-/-/-	•/-/-/-
Door hinge right / left / reversible		•/-/•	•/-/•	•/-/•	-/•/•
Full panelling / door panelling		-/-	-/-	-/-	-/-
Volume / consumption data					
Total volume	(l)	223	269	289	212
- Volume of cooling	(l)	101	171	206	-
- Volume of fresh cooling 0°C/ Fresh cooling <> 0°C	(l)	55	83	83	-
- Volume of freezing	(l)	67	15	-	212
Energy efficiency class					
Daily energy consumption ¹	(kWh/24h)	0.550	0.504	0.328	0.580
Annual energy consumption ¹	(kWh)	201	184	120	235
Noise level	(dB (A) re 1 pW)	37	36	36	35
Noise efficiency class		C	C	C	B
Climate class ²		SN - T	SN - T	SN - T	SN - T
Features					
Ice and water dispenser with ice cubes / crushed ice / water		-/-/-	-/-/-	-/-/-	-/-/-
Fresh cooling zones with humidity control	(No.)	•	•	•	-
Temperature / climate zones	(No.)	4	4	3	1
Temperature display internal / external		•/-	•/-	•/-	•/-
Temperature adjustable to the precise degree		•	•	•	•
No-Frost technology		•	-	-	•
Automatic defrosting: cooling / fresh cooling / freezing		•/•/•	•/•/-	•/•/-	-/-/•
Activated charcoal air filter		-	-	-	-
Holiday mode		•	-	-	-
Malfunction, visual / audible warning signal		•/•	•/•	•/•	•/•
Door open, visual / audible warning signal or door lock indication		•/•	•/•	•/•	•/•
Digital services (Home Connect) wireless via WiFi. ³		•	•	•	•
Cooling / fresh cooling					
Fast cooling		•	•	•	-
Dynamic cold air distribution		-	-	-	-
Levels in the interior	(No.)	3	6	7	-
Containers / drawers in the interior	(No.)	2	3	3	-
Door racks	(No.)	2	4	4	-
Bottle support, maple wood		2	2	2	-
Egg racks	(No. of eggs)	12	12	12	-
Freezing					
Fast freezing		•	-	-	•
Freezing capacity	(kg/24h)	7	2.8	-	14
Storage time after a malfunction	(hrs.)	8	9.5	-	9
Interior compartments	(No.)	-	-	-	4
Baskets, containers, drawers in the interior	(No.)	3	-	-	3
Door racks	(No.)	-	-	-	-
Ice cube trays	(No.)	1	1	-	1
Ice packs	(No.)	2	-	-	-
Connection					
Total connected load	(kW)	0.09	0.09	0.09	0.12
Water connection inlet		-	-	-	-

• Standard. - Not available. ◊ Special accessory.

¹ Effective consumption depends on the use/location of appliance.

² The appliance is fully functional within the room temperature limits defined in the following climate classes: SN-ST (+10 °C to +38 °C), SN-T (+10 °C to +43 °C).

³ The use of the Home Connect functionality depends on the Home Connect services, which are not available in every country.

Cooling 200 series



Appliance type		Fridge-freezer combination	Fridge-freezer combination
Fully integrated / integrated		RB 282 306	RT 282 306
Stainless steel door, dark anthracite		RY 295 350	
Dimensions			
Appliance dimensions W x H x D	(cm)	90.5 x 183 x 70.6	55.8 x 177.2 x 54.5
Niche dimensions W x H x D	(cm)	–	56 x 177.5 x 55
Depth including wall clearance	(cm)	73.1	55
Weight when empty	(kg)	159	75
Shipping weight	(kg)	167	80
Transport package dimensions W x H x D	(cm)	99.8 x 197.5 x 80.4	62 x 184 x 64
Type and configuration			
Cooling / freezing / wine	•/•/–	•/•/–	•/•/–
Fresh cooling 0°C / fresh cooling <> 0°C / fresh cooling	•/–/–	–/•/–	–/•/–
Fully integrated / integrated / under-counter / free-standing	–/–/–/•	•/–/–/–	•/–/–/–
Door hinge right / left / reversible	•/•/–	•/–/•	•/–/•
Full panelling / door panelling	•/–	–/–	–/–
Volume / consumption data			
Total volume	(l)	573	223
– Total volume all cooling compartments	(l)	–	–
– Volume of cooling	(l)	335	101
– Volume of fresh cooling 0°C / Fresh cooling <> 0°C	(l)	67	55
– Volume of freezing	(l)	171	67
Energy efficiency class			
Daily energy consumption ¹	(kWh/24h)	0.760	0.550
Annual energy consumption ¹	(kWh)	333	201
Noise level	(dB (A) re 1 pW)	39	37
Noise efficiency class		C	C
Climate class ²		SN – T	SN – T
Features			
Ice and water dispenser with ice cubes / crushed ice / water	•/•	–/–/–	–/–/–
Fresh cooling zones with temperature control	•	•	•
Fresh cooling zones with humidity control	•	•	•
Temperature / climate zones	(No.)	3	4
Temperature display internal / external	•/–	•/–	•/–
Temperature adjustable to the precise degree	•	•	•
No-Frost technology	•	•	–
Automatic defrosting: cooling / fresh cooling system / freezing	•/•/–	•/•/•	•/•/–
Brightness settings of lighting	(No.)	5	–
Defrost assistance freezing	•	•	–
Activated charcoal air filter	•	–	–
Holiday mode	•	•	–
Malfunction, visual / audible warning signal	•/•	•/•	•/•
Door open, visual / audible warning signal or door lock indication	•/•	•/•	•/•
Digital services (Home Connect) wireless via WiFi. ³	•	•	•
Cooling / fresh cooling			
Fast cooling	•	•	•
Dynamic cold air distribution	•	–	–
Levels in the interior	(No.)	7	3
Containers / drawers in the interior	(No.)	3	2
Door racks	(No.)	6	2
Wine and champagne rack, fold-away	–	•	•
Egg racks	(No. of eggs)	–	12
Freezing			
Fast freezing	•	•	–
Freezing capacity	(kg/24h)	15	7
Storage time after a malfunction	(h)	18.5	8
Interior compartments	(No.)	–	3
Baskets, containers, drawers in the interior	(No.)	3	3
Door racks	(No.)	–	–
Ice cube trays	(No.)	–	1
Ice packs	(No.)	–	2
Connection			
Total connected load	(kW)	0.18	0.09
Water connection inlet	•	–	–

• Standard. – Not available. ◦ Special accessory.

¹ Effective consumption depends on the use/location of appliance.

² The appliance is fully functional within the room temperature limits defined in the following climate classes: SN-ST (+10 °C to +38 °C), SNT (+10 °C to +43 °C).

³ The use of the Home Connect functionality depends on the Home Connect services, which are not available in every country.



Refrigerator

Freezer

Fridge-freezer combination

Refrigerator

Freezer

RC 282 306

RF 282 306

RT 202 180

RC 202 180

RF 202 180

55.8 x 177.2 x 54.5

55.8 x 177.2 x 54.5

59.8 x 82 x 54.8

59.8 x 82 x 54.8

59.8 x 82 x 54.8

56 x 177.5 x 55

56 x 177.5 x 55

60 x 82.2 x 55

60 x 82.2 x 55

60 x 82.2 x 55

55

55

55

55

55

68

66

32

32

32

74

70

35

35

35

62 x 184 x 64

62 x 184 x 64

67 x 89 x 62

67 x 89 x 62

67 x 89 x 62

•/•/-

-/•/-

•/•/-

•/•/-

-/•/-

-/•/-

-/-/-

-/-/-

-/-/-

-/-/-

•/-/-/-

•/-/-/-

-/-/•/-

-/-/•/-

-/-/•/-

•/-/•

-/•/•

•/-/•

•/-/•

•/-/•

-/-

-/-

-/-

-/-

-/-

289

212

110

134

85

-

-

-

-

-

206

-

93

134

-

83

-

-

-

-

-

212

17

-

85



0.328

0.580

0.326

0.254

0.467

120

235

119

93

189

36

35

35

35

35

C

B

B

B

B

SN - T

SN - T

SN - T

SN - T

SN - T

-/-/-

-/-/-

-/-/-

-/-/-

-/-/-

•

-

-

-

-

•

-

-

-

-

3

1

2

1

1

•/-

•/-

•/-

•/-

•/-

•

•

-

-

-

-

•

-

-

•

•/•/-

-/-/•

-/-/-

-/-/-

-/-/•

-

-

-

-

-

-

-

-

-

-

-

-

•

•

•

-/-

•/•

-/-

-/-

•/-

•/•

-/•

•/•

•/•

•/•

•

•

•

•

•

•

-

•

•

-

-

-

-

-

-

7

-

2

3

-

3

-

1

1

-

5

-

3

3

-

•

-

-

-

-

12

-

6

6

-

-

•

-

-

•

-

13.8

3

-

8

-

8

9

-

9

-

7

1

-

-

-

5

-

-

3

-

-

-

-

-

-

1

1

-

1

-

-

-

-

-

0.09

0.12

0.09

0.09

0.09

-

-

-

-

-

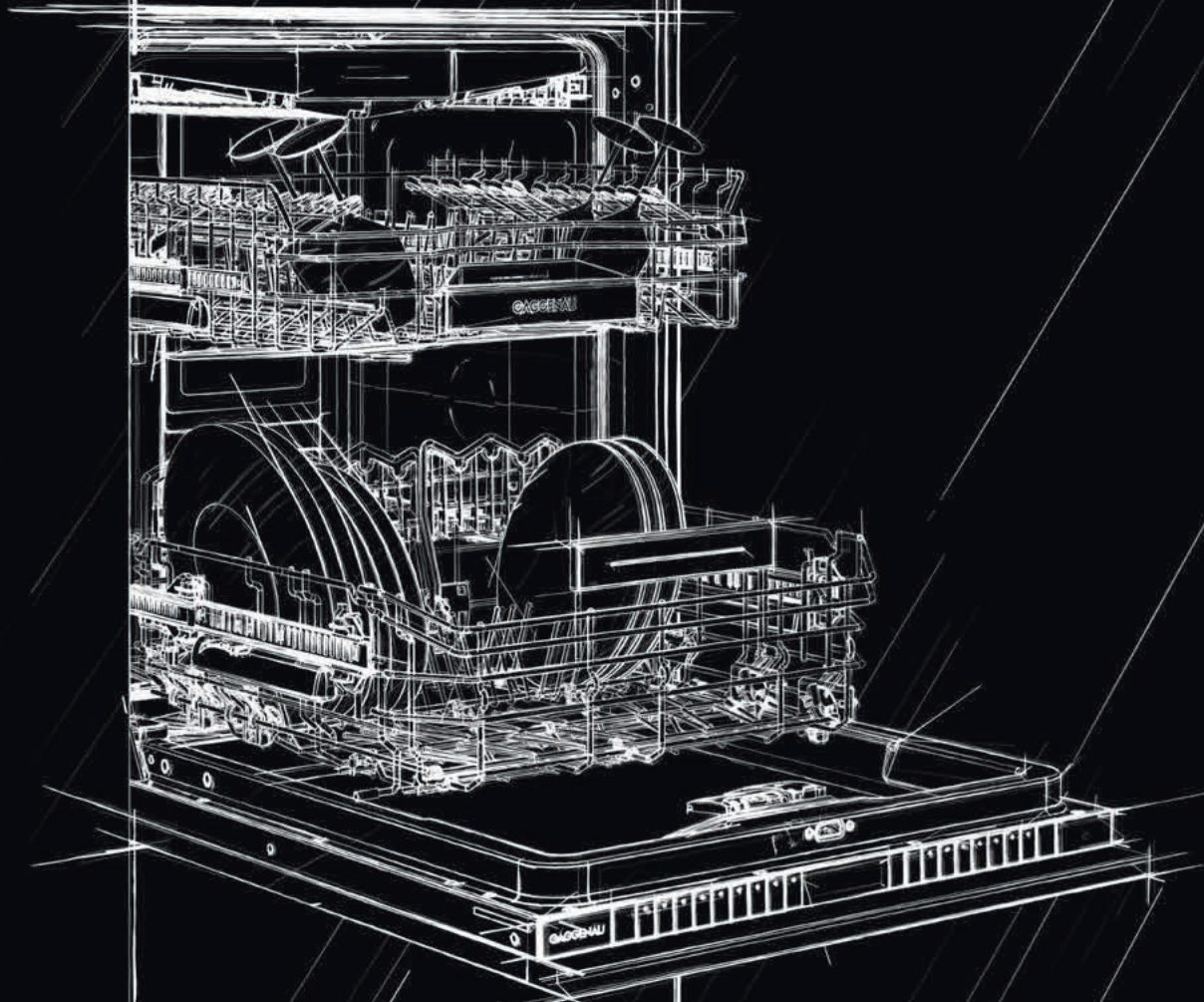

The dishwashers | washing machine | tumble dryer

Dishwashers 400 series	378
Dishwashers 200 series	382
Planning notes	392
Accessories special accessories	400
Technical specifications	402
Washing machine	404
Tumble dryer	405
Technical specifications	406



DF 481 101

Fully integrated
Height 86.5 cm

DF 480 101

Fully integrated
Height 81.5 cm



Included in the price

- 1 baking tray spray head
- 2 GN container inserts
- 1 holder for long-stemmed glasses
- 1 stainless steel trim kit

Installation accessories

DA 021 000

Hinge for all fully integrated dishwashers

GZ 010 011

Extension for water inlet and outlet (2 m long)

Special accessories

DA 041 160

Cutlery drawer with smooth running rails
3rd loading level above the upper basket.
For large pieces of cutlery, cooking utensils and espresso cups.

13 place setting capacity with all 3 levels.

DA 042 030

Silvercare cartridge for all dishwashers

DA 043 000

Holder for long-stemmed glasses
Offers safe positioning for up to four long-stemmed glasses during the dishwashing process and ensures an optimal cleaning result.
For positioning in the lower basket.

DA 045 061

3rd basket
With smooth running rails
For 86.5 cm high dishwashers
3rd loading level above the upper basket.
For small bowls, cups and cooking utensiles.
Movable knife shelf.

Dishwasher 400 series

DF 481/DF 480

- Optimal protection for sensitive glassware by low temperature drying with zeolite, elaborated basket design and intelligent water softening
- 8 programmes with aqua sensor and 4 options, such as Power for cleaning and drying dishes from 57 minutes and Intensive Plus for adjusting cleaning areas in the lower basket
- Flexible basket system with smooth running rails on all levels and cushioned closing of the upper and lower basket
- Perfectly illuminated interior
- Push-to-open function for perfect integration into handleless furniture fronts
- Remaining time projection onto the kitchen floor
- Very quiet: 43 dB

Handling

TFT display indicating remaining or end time, refill for salt and rinsing agent, inflow of water.
Touch key operation.
Flexible cycle time reduction, even during an active cycle.
Personalisation function for saving individual combinations of programmes.
Information key with use indicators.
Time delay up to 24 hours.
Visual and acoustic end of programme indicator.
Remaining time projection.

Technical features

Perfectly illuminated interior.
Glass protection with zeolite.
Aqua sensor.
Load sensor.
Detergent recognition.
Regeneration electronics.
Heat exchanger.
Continuous flow heater.
Triple filter system.
Soft lock.
Aqua stop.

Selected digital services (Home Connect)

Programme Intelligent for adapting a cycle based on user feedback.
Programme assistant.
Drying assistant for optional door opening at the end of the programme.
Temporary noise reduction.
Downloadable programmes.*

Please read additional information on Home Connect on page 411.

Programmes

8 programmes:
Auto 35 °C - 45 °C.
Auto 45 °C - 65 °C.
Auto 65 °C - 75 °C.
Intensive 70 °C.
Eco 50 °C.
Night programme.
Quick wash 45 °C (35 min.).
Personalisation function (default setting: Pre-rinse).

4 options:

Intensive Plus.
Power.
Half Load.
Hygiene.

Machine Care.

Interior

Flexible basket system with smooth running rails on all levels and cushioned closing of the upper and lower basket.

Upper basket:

Over extension.
Optional extra cleaning area by activating additional spray nozzles.
Rackmatic with 3 levels, adjustable in height up to 5 cm.
6 folding spines.
4 folding racks for optimal protection of glass.

Lower basket:

Motorised spray arm.
8 folding spines.
2 folding racks for optimal protection of glass.
Dividable glass support.
Cutlery basket.

Maximum dish sizes

(upper/lower basket)
for 86.5 cm high dishwashers:
29/28, 26.5/30.5 or 24/34 cm respectively.

Maximum dish sizes

(upper/lower basket)
for 81.5 cm high dishwashers:
27/25, 24.5/27.5 or 22/31 cm respectively.

12 place setting capacity.

Maximum glass loading capacity
23 wine glasses.

Consumption data

Energy efficiency class B at a range of energy efficiency classes from A to G.
From 9.5 l water.
From 0.626 kWh.
Noise level 43 dB (re 1 pW).

Planning notes

Height-adjustable feet.
Appliance plinth recess 100 mm (see drawing).
To display the remaining time projection, a minimum plinth protrusion is required (40 mm + thickness of the furniture front).
The maximum plinth height must be reduced by 30 mm to provide an optimal display of the remaining time projection.
Rear feet adjustable at front.
Door weight up to 10/8.5 kg.
Door panel dimension dependent on plinth height of kitchen furniture.
Installation and usage also with furniture handle possible. The push-to-open function remains active.

Please read additional planning notes on page 392 – 399.

Connection

Total connected load 2000-2400 W.
Connecting cable pluggable.
Water connection with 3/4" screw joint.
Connection to hot or cold water possible.

* Availability depending on country.

86.5 cm high dishwasher

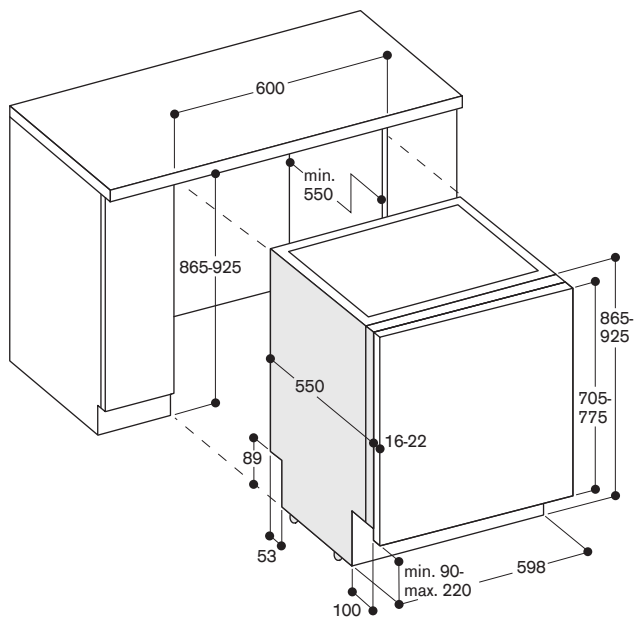

81.5 cm high dishwasher

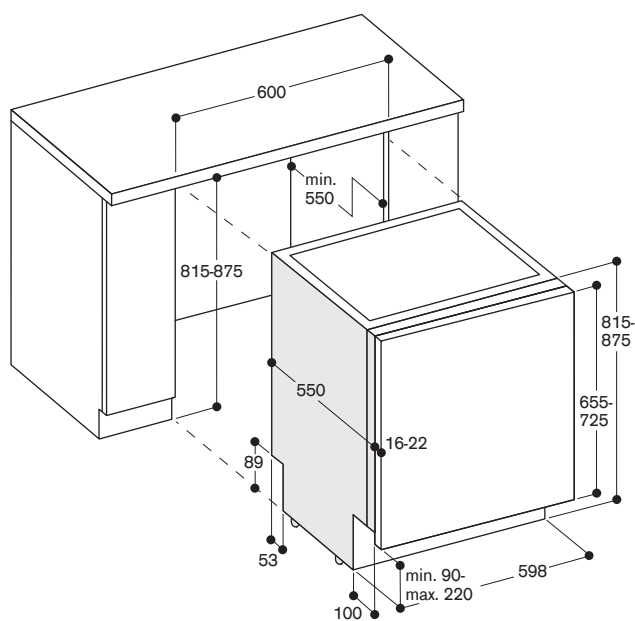

Connection dimensions for a 60 cm wide dishwasher

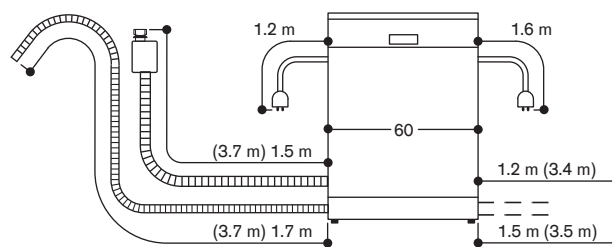

() values with extension kit



DF 481 101F

Fully integrated
Height 86.5 cm
With flexible hinge

DF 480 101F

Fully integrated
Height 81.5 cm
With flexible hinge



Included in the price

- 1 baking tray spray head
- 2 GN container inserts
- 1 holder for long-stemmed glasses
- 1 stainless steel trim kit

Installation accessories

GZ 010 011

Extension for water inlet and outlet
(2 m long)

Special accessories

DA 041 160

Cutlery drawer with smooth running rails
3rd loading level above the upper basket.
For large pieces of cutlery, cooking utensils and espresso cups.

13 place setting capacity with all 3 levels.

DA 042 030

Silvercare cartridge for all dishwashers

DA 043 000

Holder for long-stemmed glasses
Offers safe positioning for up to four long-stemmed glasses during the dishwashing process and ensures an optimal cleaning result.

For positioning in the lower basket.

DA 045 061

3rd basket

With smooth running rails

For 86.5 cm high dishwashers

3rd loading level above the upper basket.

For small bowls, cups and cooking utensiles.

Movable knife shelf.

Dishwasher 400 series

DF 481/DF 480

- Optimal protection for sensitive glassware by low temperature drying with zeolite, elaborated basket design and intelligent water softening
- 8 programmes with aqua sensor and 4 options, such as Power for cleaning and drying dishes from 57 minutes and Intensive Plus for adjusting cleaning areas in the lower basket
- Flexible basket system with smooth running rails on all levels and cushioned closing of the upper and lower basket
- Perfectly illuminated interior
- Push-to-open function for perfect integration into handleless furniture fronts
- Flexible hinge for reduced plinth height as of 50 mm or tall unit installation
- Lateral Info-Light
- Very quiet: 43 dB

Handling

TFT display indicating remaining or end time, refill for salt and rinsing agent, inflow of water.

Touch key operation.

Flexible cycle time reduction, even during an active cycle.

Personalisation function for saving individual combinations of programmes.

Information key with use indicators.

Time delay up to 24 hours.

Visual and acoustic end of programme indicator.

Lateral Info-Light.

Technical features

Perfectly illuminated interior.

Glass protection with zeolite.

Aqua sensor.

Load sensor.

Detergent recognition.

Regeneration electronics.

Heat exchanger.

Continuous flow heater.

Triple filter system.

Soft lock.

Aqua stop.

Selected digital services

(Home Connect)

Programme Intelligent for adapting a cycle based on user feedback.

Programme assistant.

Drying assistant for optional door opening at the end of the programme.

Temporary noise reduction.

Downloadable programmes.*

Please read additional information on Home Connect on page 411.

Programmes

8 programmes:

Auto 35 °C - 45 °C.

Auto 45 °C - 65 °C.

Auto 65 °C - 75 °C.

Intensive 70 °C.

Eco 50 °C.

Night programme.

Quick wash 45 °C (35 min.).

Personalisation function

(default setting: Pre-rinse).

4 options:
Intensive Plus.
Power.
Half Load.
Hygiene.

Machine Care.

Interior

Flexible basket system with smooth running rails on all levels and cushioned closing of the upper and lower basket.

Upper basket:

Over extension.

Optional extra cleaning area by activating additional spray nozzles.

Rackmatic with 3 levels, adjustable in height up to 5 cm.

6 folding spines.

4 folding racks for optimal protection of glass.

Lower basket:

Motorised spray arm.

8 folding spines.

2 folding racks for optimal protection of glass.

Dividable glass support.

Cutlery basket.

Maximum dish sizes

(upper/lower basket)

for 86.5 cm high dishwashers:

29/28, 26.5/30.5 or 24/34 cm

respectively.

Maximum dish sizes

(upper/lower basket)

for 81.5 cm high dishwashers:

27/25, 24.5/27.5 or 22/31 cm

respectively.

12 place setting capacity.

Maximum glass loading capacity

23 wine glasses.

Consumption data

Energy efficiency class B at a range of energy efficiency classes from A to G.

From 9.5 l water.

From 0.626 kWh.

Noise level 43 dB (re 1 pW).

Planning notes

Height-adjustable feet.

Appliance plinth recess 100 mm

(see drawing).

Rear feet adjustable at front.

Door weight up to 11 kg.

Door panel dimension dependent on plinth height of kitchen furniture.

Installation and usage also with furniture handle possible. The

push-to-open function remains active.

Please read additional planning notes,

also concerning flexible hinge, on

page 392 – 399.

Connection

Total connected load 2000-2400 W.

Connecting cable pluggable.

Water connection with 3/4" screw joint.

Connection to hot or cold water possible.

* Availability depending on country.

86.5 cm high dishwasher with flexible hinge

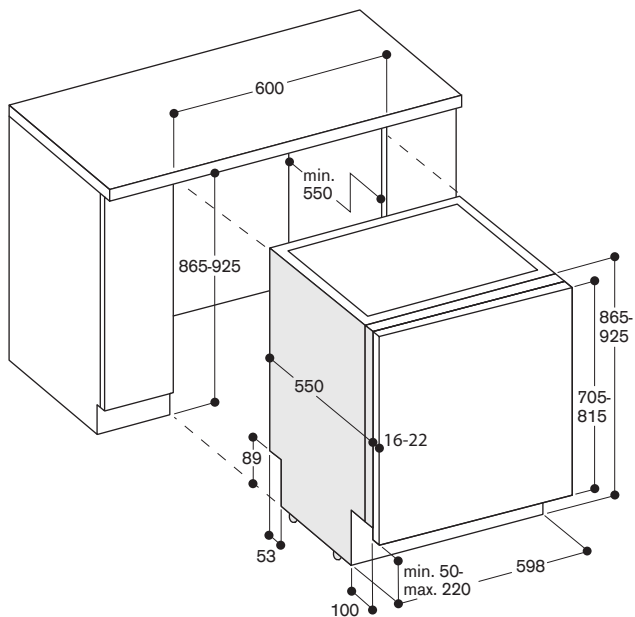

81.5 cm high dishwasher with flexible hinge

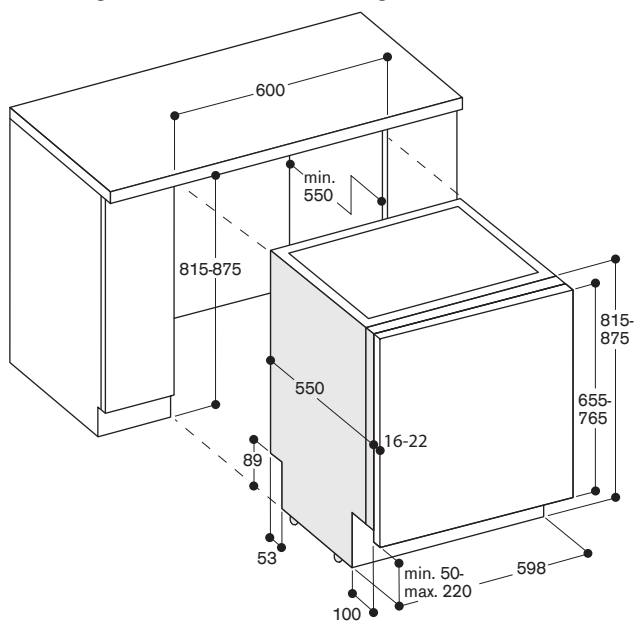

Connection dimensions for a 60 cm wide dishwasher

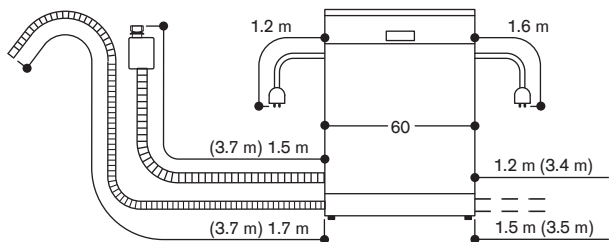

() values with extension kit



DF 271 101

Fully integrated
Height 86.5 cm

DF 270 101

Fully integrated
Height 81.5 cm



Included in the price

- 1 baking tray spray head
- 1 stainless steel trim kit

Installation accessories

DA 021 000

Hinge for all fully integrated dishwashers

GZ 010 011

Extension for water inlet and outlet (2 m long)

Special accessories

DA 041 160

Cutlery drawer with smooth running rails
3rd loading level above the upper basket.
For large pieces of cutlery, cooking utensils and espresso cups.
13 place setting capacity with all 3 levels.

DA 042 030

Silvercare cartridge for all dishwashers

DA 043 000

Holder for long-stemmed glasses
Offers safe positioning for up to four long-stemmed glasses during the dishwashing process and ensures an optimal cleaning result.
For positioning in the lower basket.

DA 045 061

3rd basket
With smooth running rails
For 86.5 cm high dishwashers
3rd loading level above the upper basket.
For small bowls, cups and cooking utensils.
Movable knife shelf.

Dishwasher 200 series

DF 271/DF 270

- Optimal protection for sensitive glassware by low temperature drying with zeolite, elaborated basket design and intelligent water softening
- 6 programmes with aqua sensor and 3 options, such as Power for cleaning and drying dishes from 57 minutes and Intensive for particularly thorough cleaning in the lower basket
- Flexible basket system with smooth running rails on all levels
- Bright interior lighting
- Push-to-open function for perfect integration into handleless furniture fronts
- Remaining time projection onto the kitchen floor
- Very quiet: 43 dB

Handling

TFT display indicating remaining or end time, refill for salt and rinsing agent, inflow of water.
Touch key operation.
Flexible cycle time reduction, even during an active cycle.
Personalisation function for saving individual combinations of programmes.
Information key with use indicators.
Time delay up to 24 hours.
Visual and acoustic end of programme indicator.
Remaining time projection.

Technical features

Bright interior lighting.
Glass protection with zeolite.
Aqua sensor.
Load sensor.
Detergent recognition.
Regeneration electronics.
Heat exchanger.
Continuous flow heater.
Triple filter system.
Soft lock.
Aqua stop.

Selected digital services (Home Connect)

Downloadable programmes.*
Programme assistant.
Temporary noise reduction.
Drying assistant for optional door opening at the end of the programme.

Please read additional information on Home Connect on page 411.

Programmes

6 programmes:
Auto 35 °C - 45 °C.
Auto 45 °C - 65 °C.
Auto 65 °C - 75 °C.
Eco 50 °C.
Quick wash 45 °C (35 min.).
Personalisation function (default setting: Pre-rinse).

3 options:
Intensive.
Power.
Half Load.

Machine Care.

Interior

Flexible basket system with smooth running rails on all levels.

Upper basket:

Over extension.
Optional extra cleaning area by activating additional spray nozzles.
Rackmatic with 3 levels, adjustable in height up to 5 cm.
6 folding spines.
4 folding racks for optimal protection of glass.

Lower basket:

8 folding spines.
2 folding racks for optimal protection of glass.
Dividable glass support.
Cutlery basket.

Maximum dish sizes

(upper/lower basket)
for 86.5 cm high dishwashers:
29/28, 26.5/30.5 or 24/34 cm respectively.

Maximum dish sizes

(upper/lower basket)
for 81.5 cm high dishwashers:
27/25, 24.5/27.5 or 22/31 cm respectively.

12 place setting capacity.
Maximum glass loading capacity
23 wine glasses.

Consumption data

Energy efficiency class B at a range of energy efficiency classes from A to G.
From 9.5 l water.
From 0.725 kWh.
Noise level 43 dB (re 1 pW).

Planning notes

Height-adjustable feet.
Appliance plinth recess 100 mm (see drawing).
To display the remaining time projection, a minimum plinth protrusion is required (40 mm + thickness of the furniture front).
The maximum plinth height must be reduced by 30 mm to provide an optimal display of the remaining time projection.
Rear feet adjustable at front.
Door weight up to 10/8.5 kg.
Door panel dimension dependent on plinth height of kitchen furniture.
Installation and usage also with furniture handle possible. The push-to-open function remains active.

Please read additional planning notes on page 392 – 399.

Connection

Total connected load 2000-2400 W.
Connecting cable pluggable.
Water connection with 3/4" screw joint.
Connection to hot or cold water possible.

* Availability depending on country.

86.5 cm high dishwasher

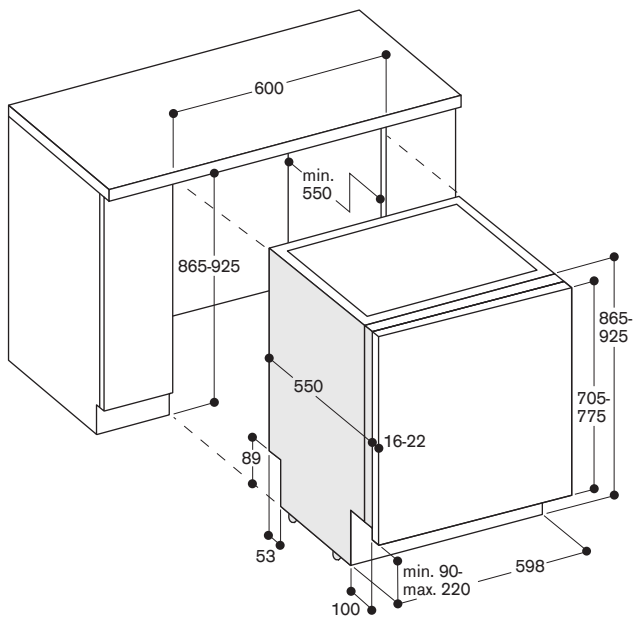

81.5 cm high dishwasher

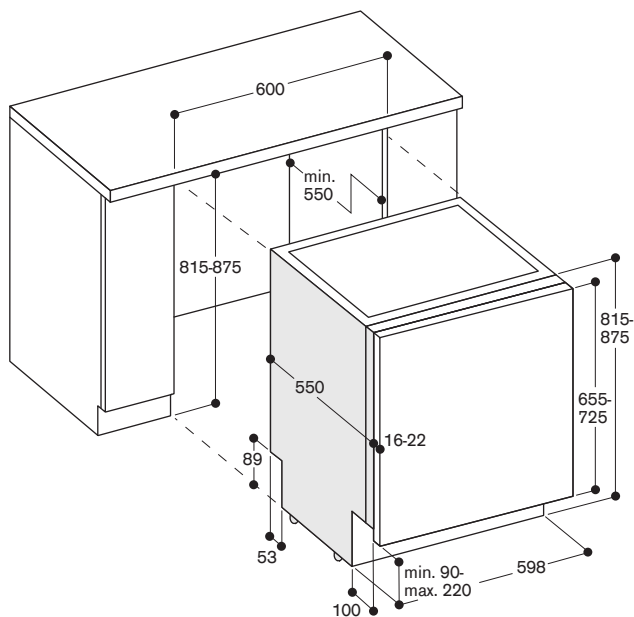

Connection dimensions for a 60 cm wide dishwasher

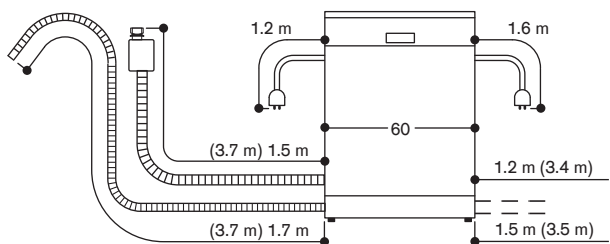

() values with extension kit



DF 271 101F

Fully integrated
Height 86.5 cm
With flexible hinge

DF 270 101F

Fully integrated
Height 81.5 cm
With flexible hinge



Included in the price

- 1 baking tray spray head
- 1 stainless steel trim kit

Installation accessories

GZ 010 011

Extension for water inlet and outlet
(2 m long)

Special accessories

DA 041 160

Cutlery drawer with smooth running rails
3rd loading level above the upper basket.
For large pieces of cutlery, cooking utensils and espresso cups.
13 place setting capacity with all 3 levels.

DA 042 030

Silvercare cartridge for all dishwashers

DA 043 000

Holder for long-stemmed glasses
Offers safe positioning for up to four long-stemmed glasses during the dishwashing process and ensures an optimal cleaning result.

For positioning in the lower basket.

DA 045 061

3rd basket
With smooth running rails
For 86.5 cm high dishwashers
3rd loading level above the upper basket.
For small bowls, cups and cooking utensiles.
Movable knife shelf.

Dishwasher 200 series

DF 271/DF 270

- Optimal protection for sensitive glassware by low temperature drying with zeolite, elaborated basket design and intelligent water softening
- 6 programmes with aqua sensor and 3 options, such as Power for cleaning and drying dishes from 57 minutes and Intensive for particularly thorough cleaning in the lower basket
- Flexible basket system with smooth running rails on all levels
- Bright interior lighting
- Push-to-open function for perfect integration into handleless furniture fronts
- Flexible hinge for reduced plinth height as of 50 mm or tall unit installation
- Lateral Info-Light
- Very quiet: 43 dB

Handling

TFT display indicating remaining or end time, refill for salt and rinsing agent, inflow of water.
Touch key operation.
Flexible cycle time reduction, even during an active cycle.
Personalisation function for saving individual combinations of programmes.
Information key with use indicators.
Time delay up to 24 hours.
Visual and acoustic end of programme indicator.
Lateral Info-Light.

Technical features

Bright interior lighting.
Glass protection with zeolite.
Aqua sensor.
Load sensor.
Detergent recognition.
Regeneration electronics.
Heat exchanger.
Continuous flow heater.
Triple filter system.
Soft lock.
Aqua stop.

Selected digital services (Home Connect)

Downloadable programmes.*
Programme assistant.
Temporary noise reduction.
Drying assistant for optional door opening at the end of the programme.

Please read additional information on Home Connect on page 411.

Programmes

6 programmes:
Auto 35 °C - 45 °C.
Auto 45 °C - 65 °C.
Auto 65 °C - 75 °C.
Eco 50 °C.
Quick wash 45 °C (35 min.).
Personalisation function (default setting: Pre-rinse).

3 options:
Intensive.
Power.
Half Load.

Machine Care.

Interior

Flexible basket system with smooth running rails on all levels.

Upper basket:

Over extension.
Optional extra cleaning area by activating additional spray nozzles.
Rackmatic with 3 levels, adjustable in height up to 5 cm.
6 folding spines.
4 folding racks for optimal protection of glass.

Lower basket:

8 folding spines.
2 folding racks for optimal protection of glass.
Dividable glass support.
Cutlery basket.

Maximum dish sizes (upper/lower basket)

for 86.5 cm high dishwashers: 29/28, 26.5/30.5 or 24/34 cm respectively.

Maximum dish sizes (upper/lower basket)

for 81.5 cm high dishwashers: 27/25, 24.5/27.5 or 22/31 cm respectively.

12 place setting capacity.
Maximum glass loading capacity
23 wine glasses.

Consumption data

Energy efficiency class B at a range of energy efficiency classes from A to G.
From 9.5 l water.
From 0.725 kWh.
Noise level 43 dB (re 1 pW).

Planning notes

Height-adjustable feet.
Appliance plinth recess 100 mm (see drawing).
Rear feet adjustable at front.
Door weight up to 11 kg.
Door panel dimension dependent on plinth height of kitchen furniture.
Installation and usage also with furniture handle possible. The push-to-open function remains active.

Please read additional planning notes, also concerning flexible hinge, on page 392 – 399.

Connection

Total connected load 2000-2400 W.
Connecting cable pluggable.
Water connection with 3/4" screw joint.
Connection to hot or cold water possible.

* Availability depending on country.

86.5 cm high dishwasher with flexible hinge

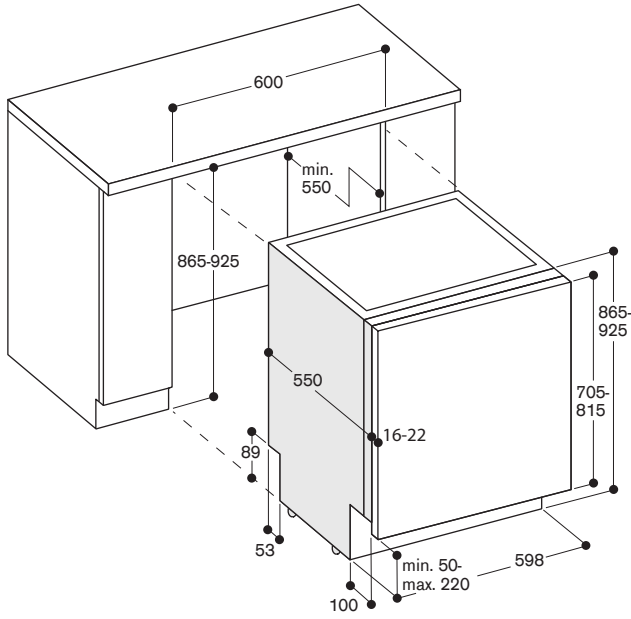

81.5 cm high dishwasher with flexible hinge

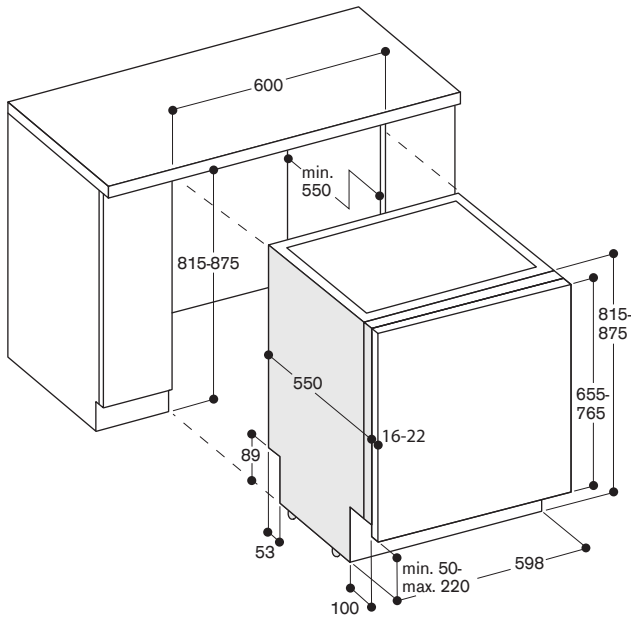

Connection dimensions for a 60 cm wide dishwasher

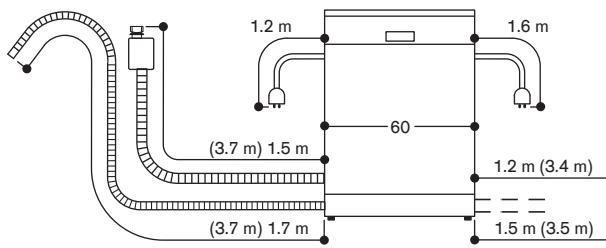

() values with extension kit



DF 261 101

Fully integrated
Height 86.5 cm

DF 260 101

Fully integrated
Height 81.5 cm



Included in the price

- 1 baking tray spray head
- 1 stainless steel trim kit

Installation accessories

DA 021 000

Hinge for all fully integrated dishwashers

GH 045 010

Handle bar with 2 mounts, stainless steel, length 45 cm, height 49 mm, drilling distance 427 mm

GZ 010 011

Extension for water inlet and outlet (2 m long)

Special accessories

DA 041 061

Cutlery drawer
3rd loading level above the upper basket.
For large pieces of cutlery, cooking utensils and espresso cups.
14 place setting capacity with all 3 levels.

DA 042 030

Silvercare cartridge for all dishwashers

DA 043 000

Holder for long-stemmed glasses
Offers safe positioning for up to four long-stemmed glasses during the dishwashing process and ensures an optimal cleaning result.

For positioning in the lower basket.

DA 045 060

3rd basket
For 86.5 cm high dishwashers
3rd loading level above the upper basket.
For small bowls, cups and cooking utensils.

Movable knife shelf.

Dishwasher 200 series

DF 261/DF 260

- Optimal protection for sensitive glassware by low temperature drying with zeolite, elaborated basket design and intelligent water softening
- 6 programmes with aqua sensor and 3 options, such as Power for cleaning and drying dishes from 57 minutes and Intensive for particularly thorough cleaning in the lower basket
- Flexible basket system
- Bright interior lighting
- Remaining time projection onto the kitchen floor
- Very quiet: 43 dB

Handling

TFT display indicating remaining or end time, refill for salt and rinsing agent, inflow of water.

Touch key operation.

Flexible cycle time reduction, even during an active cycle.

Personalisation function for saving individual combinations of programmes.

Information key with use indications.

Time delay up to 24 hours.

Visual and acoustic end of programme indicator.

Remaining time projection.

Technical features

Bright interior lighting.

Glass protection with zeolite.

Aqua sensor.

Load sensor.

Detergent recognition.

Regeneration electronics.

Heat exchanger.

Continuous flow heater.

Triple filter system.

Soft lock.

Aqua stop.

Selected digital services

(Home Connect)

Downloadable programmes.*

Programme assistant.

Temporary noise reduction.

Drying assistant for optional door opening at the end of the programme.

Please read additional information on Home Connect on page 411.

Programmes

6 programmes:

Auto 35 °C - 45 °C.

Auto 45 °C - 65 °C.

Auto 65 °C - 75 °C.

Eco 50 °C.

Quick wash 45 °C (35 min.).

Personalisation function (default setting: Pre-rinse).

3 options:

Intensive.

Power.

Half Load.

Machine Care.

Interior

Flexible basket system.

Upper basket:

Over extension.

Optional extra cleaning area by activating additional spray nozzles.

Rackmatic with 3 levels, adjustable in height up to 5 cm.

6 folding spines.

4 folding racks for optimal protection of glass.

Lower basket:

8 folding spines.

2 folding racks for optimal protection of glass.

Dividable glass support.

Cutlery basket.

Maximum dish sizes

(upper/lower basket)

for 86.5 cm high dishwashers:

29/28, 26.5/30.5 or 24/34 cm respectively.

Maximum dish sizes

(upper/lower basket)

for 81.5 cm high dishwashers:

27/25, 24.5/27.5 or 22/31 cm respectively.

13 place setting capacity.

Maximum glass loading capacity

23 wine glasses.

Consumption data

Energy efficiency class B at a range of energy efficiency classes from A to G.

From 9.5 l water.

From 0.635 kWh.

Noise level 43 dB (re 1 pW).

Planning notes

Height-adjustable feet.

Appliance plinth recess 100 mm

(see drawing).

To display the remaining time projection, a minimum plinth protrusion is required (40 mm + thickness of the furniture front).

The maximum plinth height must be reduced by 30 mm to provide an optimal display of the remaining time projection.

Rear feet adjustable at front.

Door weight up to 10/8.5 kg.

Door panel dimension dependent on plinth height of kitchen furniture.

Please read additional planning notes on page 392 – 399.

Connection

Total connected load 2000-2400 W.

Connecting cable pluggable.

Water connection with 3/4" screw joint.

Connection to hot or cold water possible.

* Availability depending on country.

86.5 cm high dishwasher

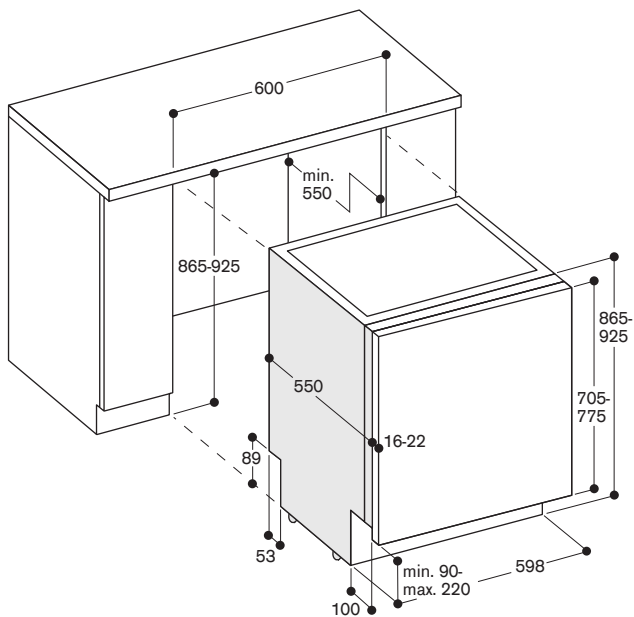

81.5 cm high dishwasher

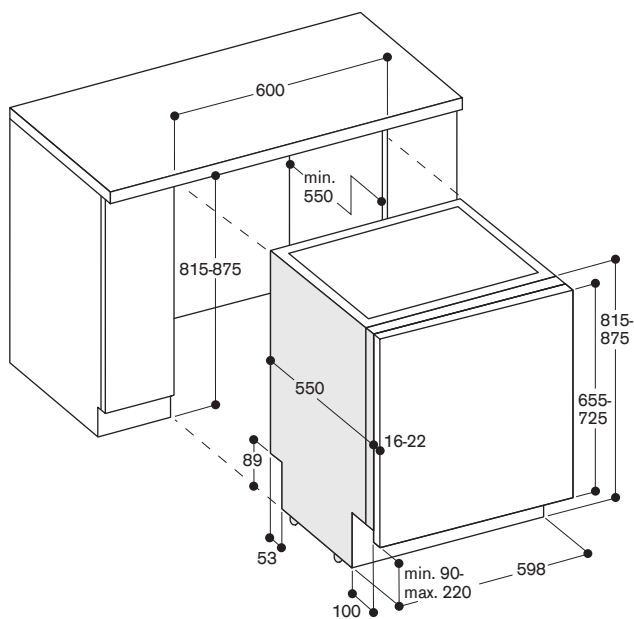

Connection dimensions for a 60 cm wide dishwasher

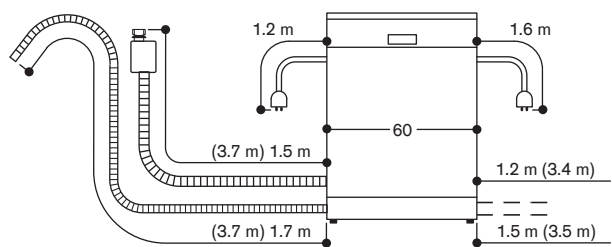

() values with extension kit



DF 211 100

Fully integrated

Height 86.5 cm

DF 210 100

Fully integrated

Height 81.5 cm



Included in the price

1 baking tray spray head

Installation accessories

DA 020 011

Stainless steel trim kit for 81.5 cm high dishwashers

DA 020 111

Stainless steel trim kit for 86.5 cm high dishwashers

DA 021 000

Hinge for all fully integrated dishwashers

GH 045 010

Handle bar with 2 mounts, stainless steel, length 45 cm, height 49 mm, drilling distance 427 mm

GZ 010 011

Extension for water inlet and outlet (2 m long)

Special accessories

DA 041 061

Cutlery drawer

3rd loading level above the upper basket.

For large pieces of cutlery, cooking utensils and espresso cups.

14 place setting capacity with all 3 levels.

DA 042 030

Silvercare cartridge for all dishwashers

DA 043 000

Holder for long-stemmed glasses

Offers safe positioning for up to four long-stemmed glasses during the dishwashing process and ensures an optimal cleaning result.

For positioning in the lower basket.

DA 045 060

3rd basket

For 86.5 cm high dishwashers

3rd loading level above the upper basket.

For small bowls, cups and cooking utensils.

Movable knife shelf.

Dishwasher 200 series

DF 211/DF 210

- 6 programmes with aqua sensor and 3 options, such as Power for cleaning and drying dishes from 57 minutes and Intensive for particularly thorough cleaning in the lower basket
- Flexible basket system
- Bright interior lighting
- Very quiet: 44 dB

Handling

TFT display indicating remaining or end time, refill for salt and rinsing agent, inflow of water.

Touch key operation.

Flexible cycle time reduction, even during an active cycle.

Personalisation function for saving individual combinations of programmes.

Information key with use indications.

Time delay up to 24 hours.

Visual and acoustic end of programme indicator.

Info-Light.

Technical features

Bright interior lighting.

Glass protection.

Aqua sensor.

Load sensor.

Detergent recognition.

Regeneration electronics.

Heat exchanger.

Continuous flow heater.

Triple filter system.

Soft lock.

Aqua stop.

Selected digital services (Home Connect)

Downloadable programmes.*

Programme assistant.

Temporary noise reduction.

Please read additional information on

Home Connect on page 411.

Programmes

6 programmes:

Auto 35 °C - 45 °C.

Auto 45 °C - 65 °C.

Auto 65 °C - 75 °C.

Eco 50 °C.

Quick wash 45 °C (29 min.).

Personalisation function

(default setting: Pre-rinse).

3 options:

Intensive.

Power.

Extra Dry.

Interior

Flexible basket system.

Upper basket:

Over extension.

Rackmatic with 3 levels, adjustable in height up to 5 cm.

6 folding spines.

4 folding racks for optimal protection of glass.

Lower basket:

8 folding spines.

2 folding racks for optimal protection of glass.

Dividable glass support.

Cutlery basket.

Maximum dish sizes

(upper/lower basket)

for 86.5 cm high dishwashers:

29/28, 26.5/30.5 or 24/34 cm respectively.

Maximum dish sizes

(upper/lower basket)

for 81.5 cm high dishwashers:

27/25, 24.5/27.5 or 22/31 cm respectively.

13 place setting capacity.

Maximum glass loading capacity

23 wine glasses.

Consumption data

Energy efficiency class D at a range of energy efficiency classes from A to G.

From 9.5 l water.

From 0.836 kWh.

Noise level 44 dB (re 1 pW).

Planning notes

Height-adjustable feet.

Appliance plinth recess 100 mm

(see drawing).

Rear feet adjustable at front.

Door weight up to 10/8.5 kg.

Door panel dimension dependent on

plinth height of kitchen furniture.

Please read additional planning notes

on page 392 – 399.

Connection

Total connected load 2000-2400 W.

Connecting cable pluggable.

Water connection with 3/4" screw joint.

Connection to hot or cold water possible.

* Availability depending on country.

86.5 cm high dishwasher

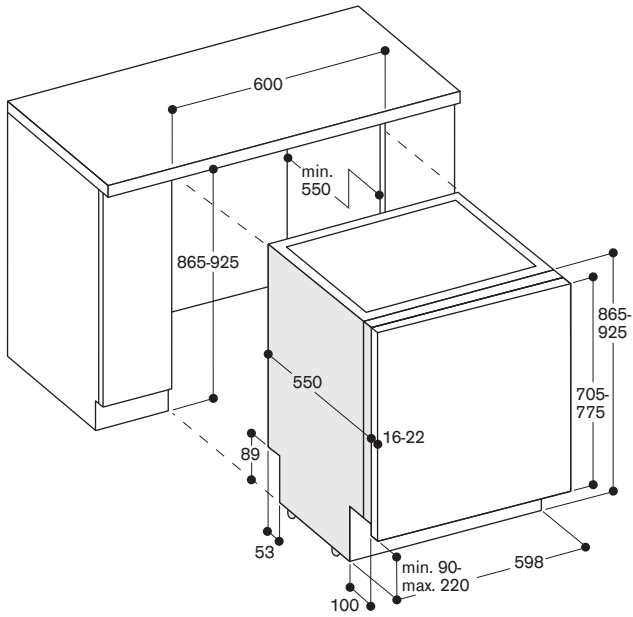

81.5 cm high dishwasher

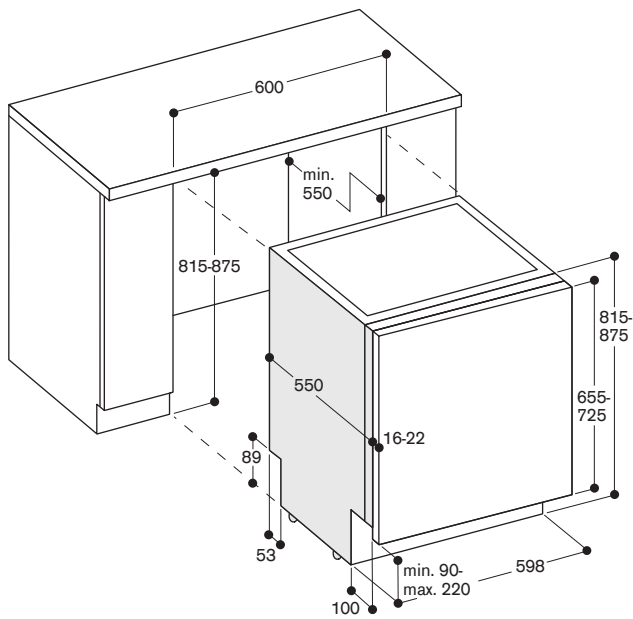

Connection dimensions for a 60 cm wide dishwasher

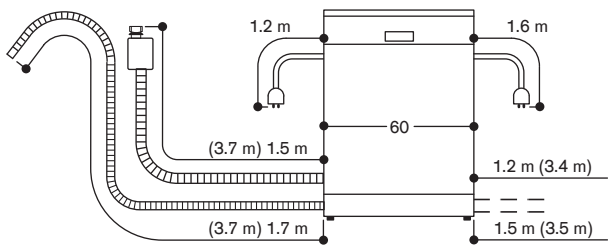

() values with extension kit



DF 264 101

Fully integrated

Height 81.5 cm, width 45 cm



Included in the price

1 baking tray spray head

Special accessories

DA 020 041

Stainless steel trim kit for 81.5 cm high and 45 cm wide dishwashers

DA 021 000

Hinge for all fully integrated dishwashers

DA 042 030

Silvercare cartridge for all dishwashers

GZ 010 011

Extension for water inlet and outlet (2 m long)

Dishwasher 200 series

DF 264

- Optimal protection for sensitive glassware by low temperature drying with zeolite, elaborated basket design and intelligent water softening
- 6 programmes with aqua sensor and option Power for cleaning and drying dishes from 57 minutes
- Flexible basket system including cutlery drawer for optimal loading
- Remaining time projection onto the kitchen floor
- Bright interior lighting
- Very quiet: 43 dB

Handling

Display indicating remaining or end time, refill for salt and rinsing agent, inflow of water.

Flexible cycle time reduction, even during an active cycle.

Personalisation function for saving individual combinations of programmes.

Time delay up to 24 hours.

Visual and acoustic end of programme indicator.

Remaining time projection.

Technical features

Bright interior lighting.

Glass protection with zeolite.

Aqua sensor.

Load sensor.

Detergent recognition.

Regeneration electronics.

Heat exchanger.

Continuous flow heater.

Low maintenance filter system.

Soft lock.

Aqua stop.

Selected digital services

(Home Connect)

Programme assistant.

Temporary noise reduction.

Drying assistant for optional door opening at the end of the programme.

Please read additional information on Home Connect on page 411.

Programmes

6 programmes:

Auto 35 °C - 45 °C.

Auto 45 °C - 65 °C.

Intensive. Eco 50 °C.

Quick wash 45 °C (29 min.).

Personalisation function

(default setting: Pre-rinse).

1 Option:

Power.

Machine Care.

Interior

Flexible basket system.

Cutlery drawer.

Upper basket:

Rackmatic with 3 levels, adjustable in height up to 5 cm.

3 folding spines.

1 folding rack.

Lower basket:

4 folding spines.

1 folding rack.

Glass support.

Maximum dish sizes

(upper/lower basket)

21/26, 18.5/28.5 or 16/31 cm respectively.

10 place setting capacity.

Consumption data

Energy efficiency class B at a range of

energy efficiency classes from A to G.

From 8.5 l water.

From 0.512 kWh.

Noise level 43 dB (re 1 pW).

Planning notes

Height-adjustable feet.

Appliance plinth recess 100 mm

(see drawing).

To display the remaining time projection, a minimum plinth protrusion is required (40 mm + thickness of the furniture front).

The maximum plinth height must be reduced by 30 mm to provide an optimal display of the remaining time projection.

Rear feet adjustable at front.

Door weight up to 7.5 kg.

Door panel dimension dependent on plinth height of kitchen furniture.

Please read additional planning notes on page 392 – 399.

Connection

Total connected load 2.0 kW - 2.4 kW.

Connecting cable pluggable.

Water connection with 3/4" screw joint.

Connection to hot or cold water possible.

Power consumption standby/network 2.0 W.

Time auto-standby/network 2 min.

Please check the user manual for how to switch off the WiFi module.

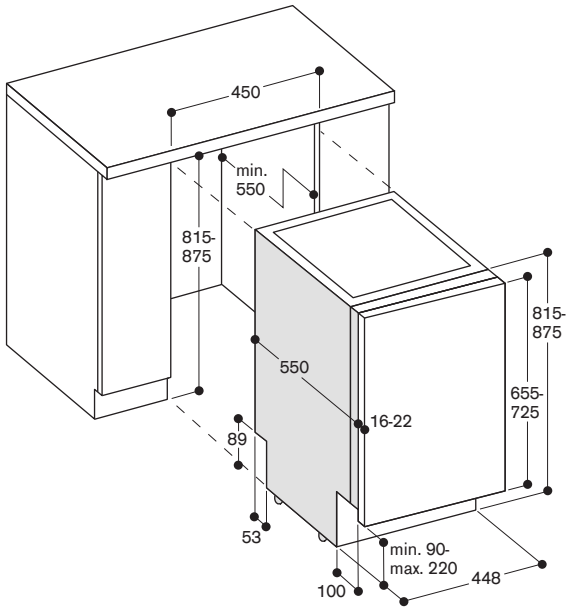

Connection dimensions for a 45 cm wide dishwasher

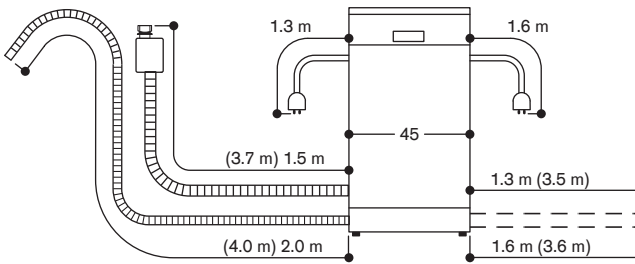

() values with extension kit

Additional planning notes for standard dishwashers (without flexible hinge)

For niche heights from 815 to 855 mm, in most cases, the 81.5 cm high dishwasher must be planned, regardless of the plinth height.

For niche heights from 885 to 925 mm, in most cases, the 86.5 cm high dishwasher must be planned, regardless of the plinth height.

If the niche height amounts to 865 or 875 mm, please note:
Whether the 81.5 cm high dishwasher or the 86.5 cm high dishwasher can be used here depends on the plinth height.

For dishwasher with remaining time projection, the maximum plinth height must be reduced by 30 mm to provide an optimal display.

Plinth height in mm	Front height 655-765 mm											Front height 705-815 mm					
	Niche height in mm →																
	815	825	835	845	855	865	875	885	895	905	915	925					
<90	1 (S)	1 (S)	1 (S)	1 (S)	1 (S)	6 (S)	6 (S)	6 (S)	6 (S)	6 (S)	6 (S)	6 (S)	6 (S)	6 (S)	6 (S)	6 (S)	6 (S)
90	1	1 (S/D)	1 (S)	1 (S)	1 (S)	6	6 (S)	6 (S)	6 (S)	6 (S)	6 (S)	6 (S)	6 (S)	6 (S)	6 (S)	6 (S)	6 (S)
100	1	1	1 (S/D)	1 (S)	1 (S)	1 (S) 6	6	6 (S/D)	6 (S)	6 (S)	6 (S)	6 (S)	6 (S)	6 (S)	6 (S)	6 (S)	6 (S)
110	1	1	1	1 (S/D)	1 (S)	1 (S) 6	1 (S) 6	6	6 (S/D)	6 (S)	6 (S)	6 (S)	6 (S)	6 (S)	6 (S)	6 (S)	6 (S)
120	1	1	1	1	1 (S/D)	1 (S) 6	1 (S) 6	6	6	6 (S/D)	6 (S)	6 (S)	6 (S)	6 (S)	6 (S)	6 (S)	6 (S)
130	1	1	1	1	1	1 (S/D) 6	1 (S) 6	6	6	6	6 (S/D)	6 (S)	6 (S)	6 (S)	6 (S)	6 (S)	6 (S)
140	1	1	1	1	1	1 6	1 (S/D) 6	6	6	6	6	6 (S/D)	6 (S)	6 (S)	6 (S)	6 (S)	6 (S)
150	1	1	1	1	1	1 6	1 6	6	6	6	6	6	6	6	6	6	6
160	1	1	1	1	1	1 6	1 6	6	6	6	6	6	6	6	6	6	6
170		1	1	1	1	1	1 6	6	6	6	6	6	6	6	6	6	6
180			1	1	1	1	1	6	6	6	6	6	6	6	6	6	6
190				1	1	1	1		6	6	6	6	6	6	6	6	6
200					1	1	1			6	6	6	6	6	6	6	6
210						1	1					6	6	6	6	6	6
220							1									6	6

- 1 = 81.5 cm high dishwasher DF 480/DF 270/DF 260/DF 210, (S) = special solution
- 6 = 86.5 cm high dishwasher DF 481/DF 271/DF 261/DF 211, (S) = special solution
- (S) = special solution with folding hinge (DA 021 000) / divided kitchen furniture door
- (D) = special solution with 10 mm gap from the worktop → Spacer batten / child lock not possible

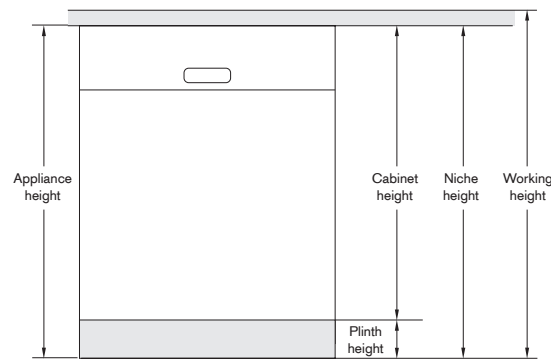

Tall unit installation of dishwashers without slanted drawer panel

The table contains the gap size required between the kitchen furniture door panel and drawer panel with reference to niche height, plinth height and panel thickness when using a standard kitchen furniture door panel for dishwashers installed below worktops.

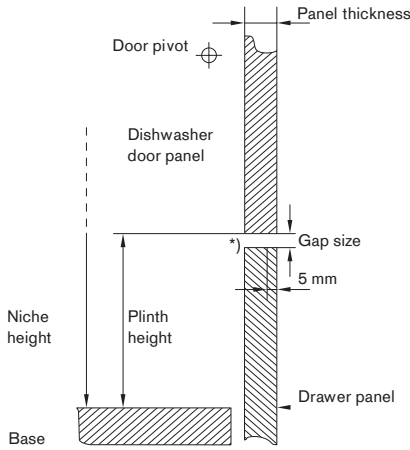

* The pivot area of the door should be at least 4 mm.

Niche height (mm)	Panel thickness (mm)		Plinth height (mm)							
	90	100	110	120	130	140	150	160	170	
815	16	10.5	11	12	13	14.5	16.5	19	22.5	
	19	12	12.5	13.5	15	16.5	18.5	22	25.5	
	22	13.5	14.5	15.5	16.5	18.5	21	24.5	28.5	
825	16	10.5	11	12	13	14.5	16.5	19	22.5	
	19	12	12.5	13.5	15	16.5	18.5	22	25.5	
	22	13.5	14.5	15.5	16.5	18.5	21	24.5	28.5	
835	16		10.5	11	12	13	14.5	16.5	19	
	19		12	12.5	13.5	15	16.5	18.5	22	
	22		13.5	14.5	15.5	16.5	18.5	21	24.5	
845	16			10.5	11	12	13	14.5	16.5	
	19			12	12.5	13.5	15	16.5	18.5	
	22			13.5	14.5	15.5	16.5	18.5	21	
855	16				10.5	11	12	13	14.5	
	19				12	12.5	13.5	15	16.5	
	22				13.5	14.5	15.5	16.5	18.5	
865	16	10.5	11	12	13	14.5	16.5	19	22.5	
	19	12	12.5	13.5	15	16.5	18.5	22	25.5	
	22	13.5	14.5	15.5	16.5	18.5	21	24.5	28.5	
875	16	10.5	11	12	13	14.5	16.5	19	22.5	
	19	12	12.5	13.5	15	16.5	18.5	22	25.5	
	22	13.5	14.5	15.5	16.5	18.5	21	24.5	28.5	
885	16		10.5	11	12	13	14.5	16.5	19	
	19		12	12.5	13.5	15	16.5	18.5	22	
	22		13.5	14.5	15.5	16.5	18.5	21	24.5	
895	16			10.5	11	12	13	14.5	16.5	
	19			12	12.5	13.5	15	16.5	18.5	
	22			13.5	14.5	15.5	16.5	18.5	21	
905	16			10.5	11	12	13	14.5	16.5	
	19			12	12.5	13.5	15	16.5	18.5	
	22			13.5	14.5	15.5	16.5	18.5	21	
915	16				10.5	11	12	13		
	19				12	12.5	13.5	15		
	22				13.5	14.5	15.5	16.5		
925	16					10.5	11	12		
	19					12	12.5	13.5		
	22					13.5	14.5	15.5		

Tall unit installation of dishwashers with slanted drawer panel

The table contains the gap size required between the kitchen furniture door panel and drawer panel with reference to niche height, plinth height and panel thickness when using a standard kitchen furniture door panel for dishwashers installed below worktops.

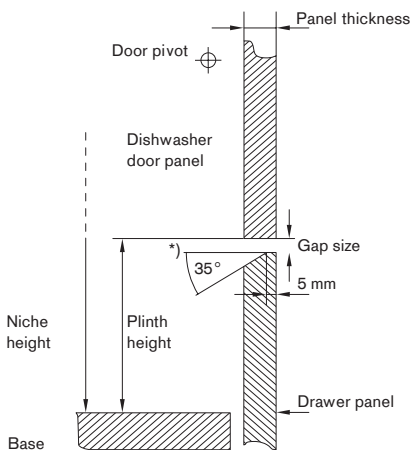

* The pivot area of the door should be at least 4 mm.

Niche height (mm)	Panel thickness (mm)		Plinth height (mm)							
	90	100	110	120	130	140	150	160	170	
815	16	6.5	6.5	7	7.5	8	9	12	15.5	
	19	7	7.5	8	8.5	9.5	11	13	17	
	22	7.5	7.5	8	9	9.5	11.5	14	18	
825	16	6.5	6.5	7	7.5	8	9	12	15.5	
	19	7	7.5	8	8.5	9.5	11	13	17	
	22	7.5	7.5	8	9	9.5	11.5	14	18	
835	16		6.5	6.5	7	7.5	8	9	12	
	19		7	7.5	8	8.5	9.5	11	13	
	22		7.5	7.5	8	9	9.5	11.5	14	
845	16			6.5	6.5	7	7.5	8	9	
	19			7	7.5	8	8.5	9.5	11	
	22			7.5	7.5	8	9	9.5	11.5	
855	16				6.5	6.5	7	7.5	8	
	19				7	7.5	8	8.5	9.5	
	22				7.5	7.5	8	9	9.5	
865	16	6.5	6.5	7	7.5	8	9	12	15.5	
	19	7	7.5	8	8.5	9.5	11	13	17	
	22	7.5	7.5	8	9	9.5	11.5	14	18	
875	16	6.5	6.5	7	7.5	8	9	12	15.5	
	19	7	7.5	8	8.5	9.5	11	13	17	
	22	7.5	7.5	8	9	9.5	11.5	14	18	
885	16		6.5	6.5	7	7.5	8	9	12	
	19		7	7.5	8	8.5	9.5	11	13	
	22		7.5	7.5	8	9	9.5	11.5	14	
895	16			6.5	6.5	7	7.5	8	9	
	19			7	7.5	8	8.5	9.5	11	
	22			7.5	7.5	8	9	9.5	11.5	
905	16				6.5	6.5	7	7.5	8	
	19				7	7.5	8	8.5	9.5	
	22				7.5	7.5	8	9	9.5	
915	16					6.5	6.5	7	7.5	
	19					7	7.5	8	8.5	
	22					7.5	7.5	8	9	
925	16						6.5	6.5	7	
	19						7	7.5	8	
	22						7.5	7.5	8	

Additional planning notes for dishwashers with flexible hinge

For niche heights from 815 to 860 mm, in most cases, the 81.5 cm high dishwasher must be planned, regardless of the plinth height.

For niche heights from 880 to 925 mm, in most cases, the 86.5 cm high dishwasher must be planned, regardless of the plinth height.

If the niche height amounts between 865 and 875 mm, please note: Whether the 81.5 cm high dishwasher or the 86.5 cm high dishwasher can be used here depends on the plinth height.

If the installation of a dishwasher with **flexible hinge** is necessary or not depends on several factors.

The door panels cannot be used with dishwashers with flexible hinge.

		Front height 655–765 mm									
		Niche height in mm →									
		815	820	825	830	835	840	845	850	855	860
Plinth height in mm ↓	50	①									
	55	①	①								
60	①	①	①								
65	①	①	①	①							
70	①	①	①	①	①						
75	①	①	①	①	①	①					
80	①	①	①	①	①	①	①				
85	①	①	①	①	①	①	①	①			
90	①*	①	①	①	①	①	①	①	①	①	
95	①*	①*	①	①	①	①	①	①	①	①	①
100	①*	①*	①*	①	①	①	①	①	①	①	①
105	①*	①*	①*	①*	①	①	①	①	①	①	①
110	①*	①*	①*	①*	①*	①	①	①	①	①	①
115	①*	①*	①*	①*	①*	①*	①	①	①	①	①
120	①*	①*	①*	①*	①*	①*	①*	①	①	①	①
125	①*	①*	①*	①*	①*	①*	①*	①*	①	①	①
130	①*	①*	①*	①*	①*	①*	①*	①*	①*	①*	①
135	①*	①*	①*	①*	①*	①*	①*	①*	①*	①*	①*
140	①*	①*	①*	①*	①*	①*	①*	①*	①*	①*	①*
145	①*	①*	①*	①*	①*	①*	①*	①*	①*	①*	①*
150	①*	①*	①*	①*	①*	①*	①*	①*	①*	①*	①*
155	①*	①*	①*	①*	①*	①*	①*	①*	①*	①*	①*
160	①*	①*	①*	①*	①*	①*	①*	①*	①*	①*	①*
165		①*	①*	①*	①*	①*	①*	①*	①*	①*	①*
170			①*	①*	①*	①*	①*	①*	①*	①*	①*
175				①*	①*	①*	①*	①*	①*	①*	①*
180					①*	①*	①*	①*	①*	①*	①*
185						①*	①*	①*	①*	①*	①*
190							①*	①*	①*	①*	①*
195								①*	①*	①*	①*
200									①*	①*	①*
205										①*	①*
210											①*
215											
220											

① = 81.5 cm high dishwasher with flexible hinge DF 480 101F / DF 270 101F

② = 86.5 cm high dishwasher with flexible hinge DF 481 101F / DF 271 101F

* Also possible with dishwashers without flexible hinge.

Accessories and special accessories for dishwashers

Flexible basket system

Flexible basket system with smooth running rails on all levels and cushioned closing of the upper and

lower basket.

For more flexibility and easier handling when loading and unloading the dishwasher.

Upper basket

6 folding spines.
4 folding racks for optimal protection of glass.
With over extension, optional extra cleaning area, smooth running rails and cushioned closing as well as rackmatic with 3 levels, adjustable in height up to 5 cm.
Handle for easier removal of the upper basket.



Lower basket

8 folding spines.
2 folding racks for optimal protection of glass.
Dividable glass support.
Cutlery basket.
With smooth running rails and cushioned closing.
Handle for easier removal of the lower basket.

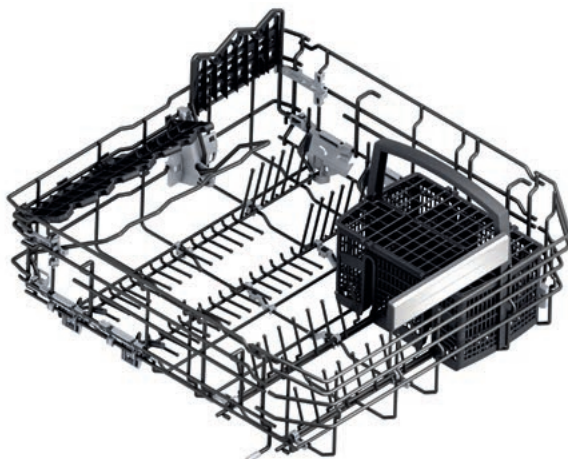

Configuration of flexible basket system depending on model.

DA 020 011

Stainless steel trim kit for all 81.5 cm high dishwashers
Set of 2, for left and right.
To cover the gap between appliance and adjacent furniture and for better fixation of the appliance in the niche.
The white frame is replaced by a stainless steel trim kit.
W x D in cm: 2.3x2.3.
Height 62.2 cm.

DA 020 111

Stainless steel trim kit for 86.5 cm high dishwashers
Set of 2, for left and right.
To cover the gap between appliance and adjacent furniture and for better fixation of the appliance in the niche.
The white frame is replaced by a stainless steel trim kit.
W x D in cm: 2.3x2.3.
Height 67.2 cm.

DA 020 041

Stainless steel trim kit for 81.5 cm high and 45 cm wide dishwashers
Set of 2, for left and right.
To cover the gap between appliance and adjacent furniture and for better fixation of the appliance in the niche.
The white frame is replaced by a stainless steel trim kit.
W x D in cm: 2.3 x 2.3.
Height 62.2 cm.

DA 021 000

Hinge for all fully integrated dishwashers
Installation solution for all dishwashers with a niche height of up to 92 cm and split furniture panel.
The hinge is fastened to the plinth of the appliance and the lower part of the split furniture panel is mounted onto it.
Height upper part of the split furniture panel:
64.5 – 68 cm for
81.5 cm high dishwashers.
69.5 – 73 cm for
86.5 cm high dishwashers.

DA 041 160

Cutlery drawer with smooth running rails
3rd loading level above the upper basket.
For large pieces of cutlery, cooking utensils and espresso cups.
13 place setting capacity with all 3 levels.

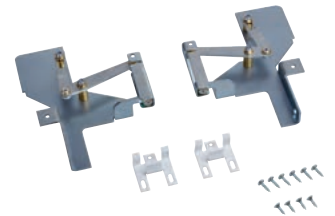
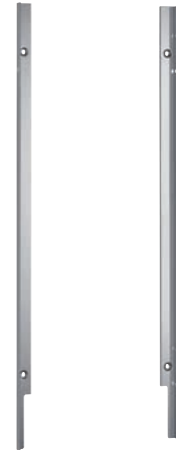

DA 041 061

Cutlery drawer
3rd loading level above the upper basket.
For large pieces of cutlery, cooking utensils and espresso cups.
14 place setting capacity with all 3 levels.

**DA 045 060**

3rd basket
For 86.5 cm high dishwashers
3rd loading level above the upper basket.
For small bowls, cups and cooking utensiles.
Movable knife shelf.

**DA 045 061**

3rd basket
With smooth running rails
For 86.5 cm high dishwashers
3rd loading level above the upper basket.
For small bowls, cups and cooking utensiles.
Movable knife shelf.

**DA 042 030**

Silvercare cartridge for all dishwashers
Made of aluminium to protect silverware from corrosion.
Easy use of cartridge in the cutlery basket.
W x H x D in cm: 5.5x20.2x4.1.

**DA 043 000**

Holder for long-stemmed glasses
Offers safe positioning for up to four long-stemmed glasses during the dishwashing process and ensures an optimal cleaning result.
For positioning in the lower basket.

**GH 045 010**

Handle bar with 2 mounts, stainless steel,
length 45 cm, height 49 mm,
drilling distance 427 mm

**GZ 010 011**

Extension for water inlet and outlet
(2 m long).



Dishwasher



Appliance type	Dishwasher	Dishwasher	Dishwasher
Model	Fully integrated	Fully integrated	Fully integrated
Appliance height 81.5 cm	DF 480 101		DF 270 101
Appliance height 86.5 cm	DF 481 101		DF 271 101
Appliance height 81.5 cm with flexible hinge		DF 480 101F	
Appliance height 86.5 cm with flexible hinge		DF 481 101F	
Width/capacity			
Width (cm)	60	60	60
Capacity in place settings	12/13 ³	12/13 ³	12/13 ³
Dish size up to (cm)	31 ¹ /34 ²	31 ¹ /34 ²	31 ¹ /34 ²
Consumption data/noise level ⁵			
Energy efficiency class			
Drying efficiency class	A	A	A
Test programme	Eco 50 °C	Eco 50 °C	Eco 50 °C
Programme duration ⁶ (h:min)	4:55	4:55	4:55
Water ⁷ (l)	9.5	9.5	9.5
Energy ⁸ (kWh)	63	63	63
Noise level (dB (A) re 1 pW)	43	43	43
Energy consumption standby/networked standby (W)	0.5/2.0	0.5/2.0	0.5/2.0
Programmes			
Number of programmes + options	8 + 4	8 + 4	6 + 3
Programmes	Auto 35 °C–45 °C Auto 45 °C–65 °C Auto 65 °C–75 °C Intensive 70 °C Eco 50 °C Night programme Quick wash 45 °C Personalisation function (Pre-rinse)	Auto 35 °C–45 °C Auto 45 °C–65 °C Auto 65 °C–75 °C Intensive 70 °C Eco 50 °C Night programme Quick wash 45 °C Personalisation function (Pre-rinse)	Auto 35 °C–45 °C Auto 45 °C–65 °C Auto 65 °C–75 °C Eco 50 °C Night programme Quick wash 45 °C Personalisation function (Pre-rinse)
Options			
	Intensive Plus Power Half Load Hygiene	Intensive Plus Power Half Load Hygiene	Intensive Power Half Load
Machine Care			
	•	•	•
Features			
Glass protection with zeolite / Glass protection	•/–	•/–	•/–
Aqua sensor / Load sensor	•/•	•/•	•/•
Automatic detergent function	•	•	•
Detergent recognition	•	•	•
Regeneration electronics	•	•	•
Heat exchanger	•	•	•
Low temperature drying with Zeolite	•	•	•
Drying assistant	•	•	•
Continuous flow heater	•	•	•
Electronic refill indicator for salt/rinsing agent	•/•	•/•	•/•
Inflow water indicator	•	•	•
Time remaining indicator	•	•	•
Remaining time projection	•	–	•
Lateral Info-Light / Info-Light	–/–	•/–	–/–
Flexible cycle time reduction	•	•	•
Bright interior lighting through illuminated backwall / through LED spots	•/–	•/–	–/•
Time delay	24 h	24 h	24 h
Digital services (Home Connect) wireless via WiFi. ¹⁰	•	•	•
Soft lock	•	•	•
Triple filter system	•	•	•
Cutlery drawer	DA 041 160 ⁹	DA 041 160 ⁹	DA 041 160 ⁹
3rd basket	DA 045 061 ^{2/9}	DA 045 061 ^{2/9}	DA 045 061 ^{2/9}
Smooth running rails / Cushioned closing	•/•	•/•	•/–
Folding spines in upper/lower basket	6/8	6/8	6/8
Folding racks in upper/lower basket	4/2	4/2	4/2
Rackmatic with 3 levels	•	•	•
Aqua stop	•	•	•
Baking tray spray head / Gastronorm insert holder / Holder for long-stemmed glasses	•/•/•	•/•/•	•/–/–
Connection			
Connection to hot/cold water possible	•/•	•/•	•/•
Total connected load (kW)	2.4	2.4	2.4

• Standard. – Not available.

¹ Appliance height 81.5 cm. ² Appliance height 86.5 cm. ³ With special accessory DA 041 160. ⁴ With special accessory DA 041 061.

⁵ Values according to EU regulation 2019/2017. ⁶ Duration of Eco programme. ⁷ Water consumption in litres/operating cycle (using Eco programme).

⁸ Energy consumption in kWh/100 operating cycles (using Eco programme).

⁹ Special accessory. ¹⁰ The use of the Home Connect functionality depends on the Home Connect services, which are not available in every country.



WM 260 165

Free-standing, slide-under or stackable
Width 60 cm, height 84.5 cm



Special accessories

WMZ2381

Extension for cold water inlet (2 m)
Diameter inside 10mm / outside 15 mm
Water inlet extension
Aqua-Stop extension

WMZPW20W

Pedestal / platform with drawer for washing machines
The pedestal increases the height of the appliance for convenient operation
Includes a drawer for space-saving storage
Dimensions: 400 x 600 x 570 mm

Washing machine

WM 260

- Intelligent dosage system iDos for liquid detergent and softener for a perfect washing result
- 10 kg drum with interior lighting
- Top-up function
- Dynamic Wash System: innovative washing technology for increased cleaning performance
- Combines perfectly with dryer WT260 165

Handling

Automatic programmes: Perfect washing results at the touch of a button.
Illuminated rotary knob with integrated On-Off switch.
Large touch display with clear text and symbols.
Loading indicator with dosage recommendation.
Programme sequence and remaining time display.
Time delay up to 24 hours.
Multiple signal tones.

Technical features

Aqua sensor.
Aqua stop.
Flow-through sensor.
Anti-stain automatic.
Continuous automatic load adjustment.
Foam detection system.
Spin speed selection from 400 to 1600 rpm.
Top-up function.
Dynamic Wash System technology for increased cleaning performance.
Automatic stabilisation.
Anti-crease system.
Child lock.

Selected digital services (Home Connect)

Smart Energy Management.
Smart Dry (Washing machine automatically selects correct dryer program).
Remote control and monitoring.

Please read additional information on Home Connect on page 411.

Programmes

Eco 40-60.
Cottons.
Eco Cottons.
Easy Care.
Quick/Mix.
Delicates/Silk.
Steam Assist.
Automatic.
Super 15/30.
Hygiene.
Wool.
Spin/Drain.
Rinse.
App Programmes: Automatic Soft, Shirts/Blouses, Dark Wash, Duvet, Sports, Drum Clean with reminder.
Options: Remote-Start, Mini Load, Favourite, Speed Perfect, Rinse Plus, Steam, Water Plus, Prewash, Stains.

Features

iDos for fully automatic dosing of liquid detergent and softener.
Volume capacity from 1 to 10 kg.
Drum interior lighting.
Powder detergent drawer with automatic cleaning mode after every wash cycle.
Stainless steel drum with wave structure.
Innovative BLDC motor technology for more performance, higher durability as well as less energy consumption and noise.

Consumption data

Energy efficiency class A at a range of energy efficiency classes from A to G.
Water consumption 48l.
Energy consumption 48 kWh per 100 cycles.

Planning notes

Left-hinged.
Large porthole with 188 ° opening angle.
Height-adjustable feet.
Height for slide-under installation: 85 cm.
Stackable under dryer WT 260 165 in combination with special accessory.
With pull-out shelf WZ27500.

Connection

Total connected load 2.3 kW.
Connection cable 160 cm with plug.
Water connection with 3/4" screw joint.

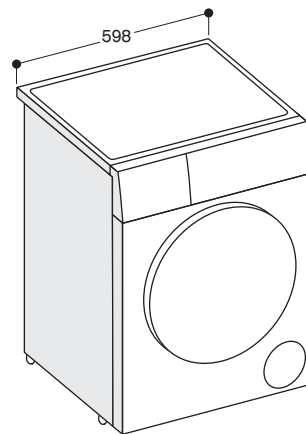

Measurements in mm

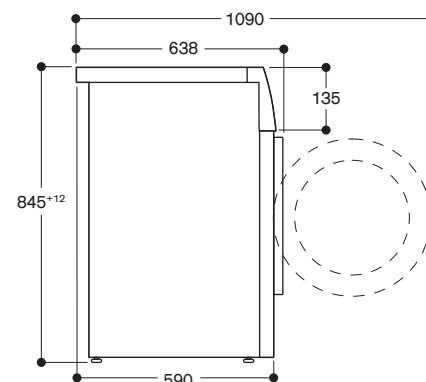

Measurements in mm

**WT 260 165**

Free-standing, slide-under or stackable
Width 60 cm, height 84.2 cm

**Special accessories****WMZ20600**

Basket for drying delicate wool fabrics, sports shoes & plush toys

For use in combination with a time-controlled warm drying program or with a special basket program

Dimensions: 360 x 310 x 310 mm

WTZ27500

Stacking kit for safe alignment of tumble dryers on top of washing machines

Allows you to stack tumble dryer on top of full-sized washing machine (depth >55cm)

Includes useful pull-out shelf for loading and unloading

Dimensions: 42 x 595 x 574 mm

WTZPW20D

Pedestal / platform with drawer for tumble dryers

The pedestal increases the height of the appliance for convenient operation
Includes a drawer for space-saving storage

Dimensions: 400 x 600 x 570 mm

Tumble dryer with heat pump**WT 260**

- Heat pump technology
- Twin rotary compressor for reduced energy consumption
- Self-cleaning condenser for automatic fluff removal
- Very silent drying with only 59 db
- Smart Dry automatically selects the right dryer program based on the last washing program

Handling

Illuminated rotary knob with integrated On-Off switch.

Large touch display with clear text and symbols.

Programme sequence and remaining time display.

Time delay up to 24 hours.

Multiple signal tones.

Technical features

Moisture and time controlled programmes.

Heat pump technology.

Self-cleaning heat exchanger.

Refresh function without previous washing cycle.

Anti-crease cycle at programme end.

Top-up function.

Child lock.

Selected digital services (Home Connect)

Smart Energy Management.

Smart Dry (Washing machine automatically selects correct dryer program).

Remote control and monitoring.

Please read additional information on Home Connect on page 411.

Programmes

Cottons.

Eco Cottons.

Easy Care.

Mix.

Super 40'.

Outdoor.

Steam Assist.

Shirts/Blouses.

Wool in Basket.

Hygiene.

Towels.

Duvet.

Timed program warm.

App Programmes: Smart Dry, Sports, Dessous, Synthetics, Down, Timed program cold.

Options: Smart Dry, Refresher

Options, Half Load, Remote Start, Anti Crease, Easy Iron, Drying Target, Spin Speed, Gentle Dry, Favourite.

Features

Stainless steel drum with honeycomb structure.

Dry wool without shrinking or matting thanks to the included basket for woollens.

Volume capacity from 1 to 9 kg.

Drum interior lighting.

Consumption data

Energy efficiency class A+++ at a range of energy efficiency classes from A+++ to D.

Planning notes

Combines perfectly with washing machine WM 260 165.

Right-hinged, reversible.

Large porthole with 180 ° opening angle.

Height-adjustable feet.

Height for slide-under installation: 84.2 cm.

Stackable above washing machine WM 260 165 in combination with special accessory. With pull-out shelf WZ27500.

Connection

Total connected load 0.6 kW.

Connection cable 145 cm with plug.

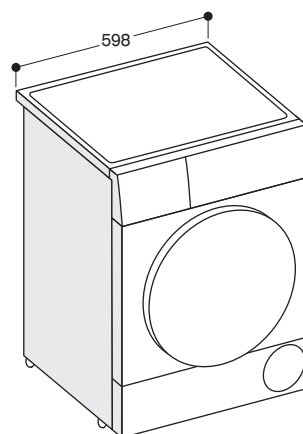

Measurements in mm

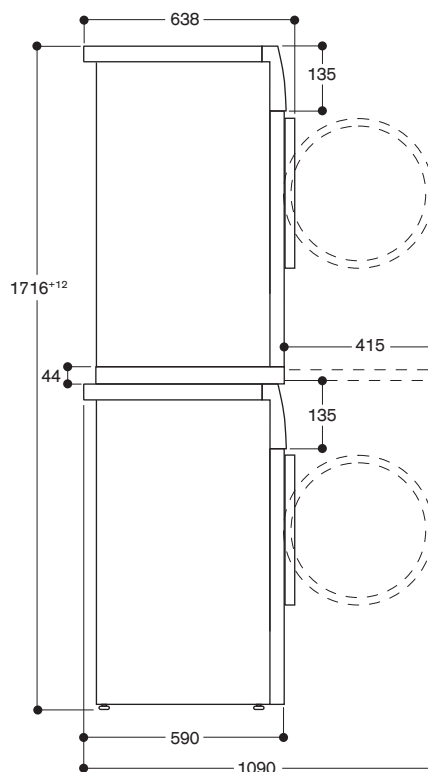
Side view of WT 260 above WM 260 with connection kit accessory

Measurements in mm

*Energy efficiency class: at a range of energy efficiency classes from A+++ to D.

Washing machine



Appliance type		Washing machine
		WM 260 165
Housing colour		Character White
Panel colour		Black
Dimensions / capacity		
Width	(cm)	60
Appliance dimensions W x H x D	(mm)	598 x 845 x 638
Appliance height for under-counter	(mm)	850
Door hinge porthole / Door opening angle		Left / 188 °
Capacity	(kg)	10
Consumption data / noise level		
Energy efficiency class ¹		
Spinning efficiency class		A
Total annual energy consumption (100 cycles) ²	(kWh)	51
Water consumption test programme ³	(l)	48
Weighted energy consumption off-mode / left-on mode	(W)	0.1/0.5
Test programme		Eco 40-60
Spin speed test programme ⁴	(rpm)	1600
Cycle time test programme full load ⁵	(min)	03:55
Noise level washing / spinning test programme	(dB)	47/69
Programmes		
Washing programmes		Eco 40-60 Cottons Eco Cottons Easy Care Quick/Mix Delicates/Silk Steam Assist Automatic Super 15/30 Hygiene Wool Spin/Drain Rinse
Additional programmes		Automatic Soft, Shirts/Blouses, Dark Wash, Duvet, Sports, Drum clean with reminder
Options		iDos 1 / iDos 2 Favourite Speed Perfect Remote Start Mini Load Stains Rinse Plus, Steam, Water Plus, Silent Wash, Prewash
Cleaning temperatures	(°C)	Cold/30/40/60/90
Features		
Electronic control		•
Large LED display with clear text and symbols		•
Loading indicator		•
Intelligent dosing system		•
Programme sequence indicator		•
Remaining time display		•
Time delay	(h)	24
Top up function		•
End of programme indicator		Display, audible
Aqua sensor / Flow-through sensor		• / •
Continuous automatic load adjustment / Automatic stabilisation		• / •
Aquastop with guarantee		•
Anti-crease system		•
Child lock		•
Number of tanks for iDos system		2
Self-cleaning detergent drawer		•
Large drum with wave structure		•
Interior lighting		•
Digital services (Home Connect) wireless via WiFi. ⁶		•
Connection		
Total connected load	(kW)	2.3
Length of connection cable	(cm)	160
Length of water inlet	(cm)	150
Length of water outlet	(cm)	150

• Standard.

¹ On an energy-efficiency class scale from A to G. ² Energy consumption in kWh/100 operating cycles (using Eco 40-60 programme).

³ Water consumption in litres/operating cycle (using Eco 40-60 programme). ⁴ The specified value is rounded off.

⁵ Duration of Eco 40-60 programme. ⁶ The use of the Home Connect functionality depends on the Home Connect services, which are not available in every country.

Values according to EU regulation 2019



Appliance type		Tumble dryer with heat pump
		WT 260 165
Housing colour		Character White
Panel colour		Black
Dimension / capacity		
Width	(cm)	60
Appliance dimensions W x H x D	(mm)	598 x 842 x 651
Appliance height for under-counter	(mm)	850
Door hinge porthole		Right, reversible
Door opening angle	(°)	180
Capacity	(kg)	9
Consumption data / noise level		
Energy efficiency class		
Total annual energy consumption (160 cycles) ¹	(kWh)	193
Test programme		Cottons cupboard dry
Noise level	(dB)	59
Programmes		
Drying programmes		Cottons Eco Cottons Easy Care Mix Super 40 Outdoor Steam Assist Shirts / Blouses Wool in Basket Hygiene Towels Duvet Timed programme warm
Additional programmes		Sports Dessous Synthetics Down Timed programme cold
Options		Favourite Smart Dry Refresher Options Half Load Remote Start Anti Crease Drying Target, Spin Speed, Gentle Dry
Features		
Electronic control		•
Large LED display with clear text and symbols		•
Programme sequence indicator		•
Remaining time display		•
Time delay	(h)	24
End of programme indicator		Display, audible
Top up function		•
Heat pump technology		•
Twin Rotary Compressor		•
Refresh function		•
Self-cleaning condenser		•
Anti-crease cycle at the end of the programme		•
Child lock		•
Stainless steel drum with wave structure		•
Glass porthole		•
Interior lighting		•
Digital services (Home Connect) wireless via WiFi. ²		•
Connection		
Total connected load	(kW)	0.6
Length of connection cable	(cm)	145
Maximum drainage height	(cm)	100

• Standard.

¹ Effective consumption depending on type of use of appliance.

² The use of the Home Connect functionality depends on the Home Connect services, which are not available in every country.

* Energy efficiency class: at a range of energy efficiency classes from A+++ to D.

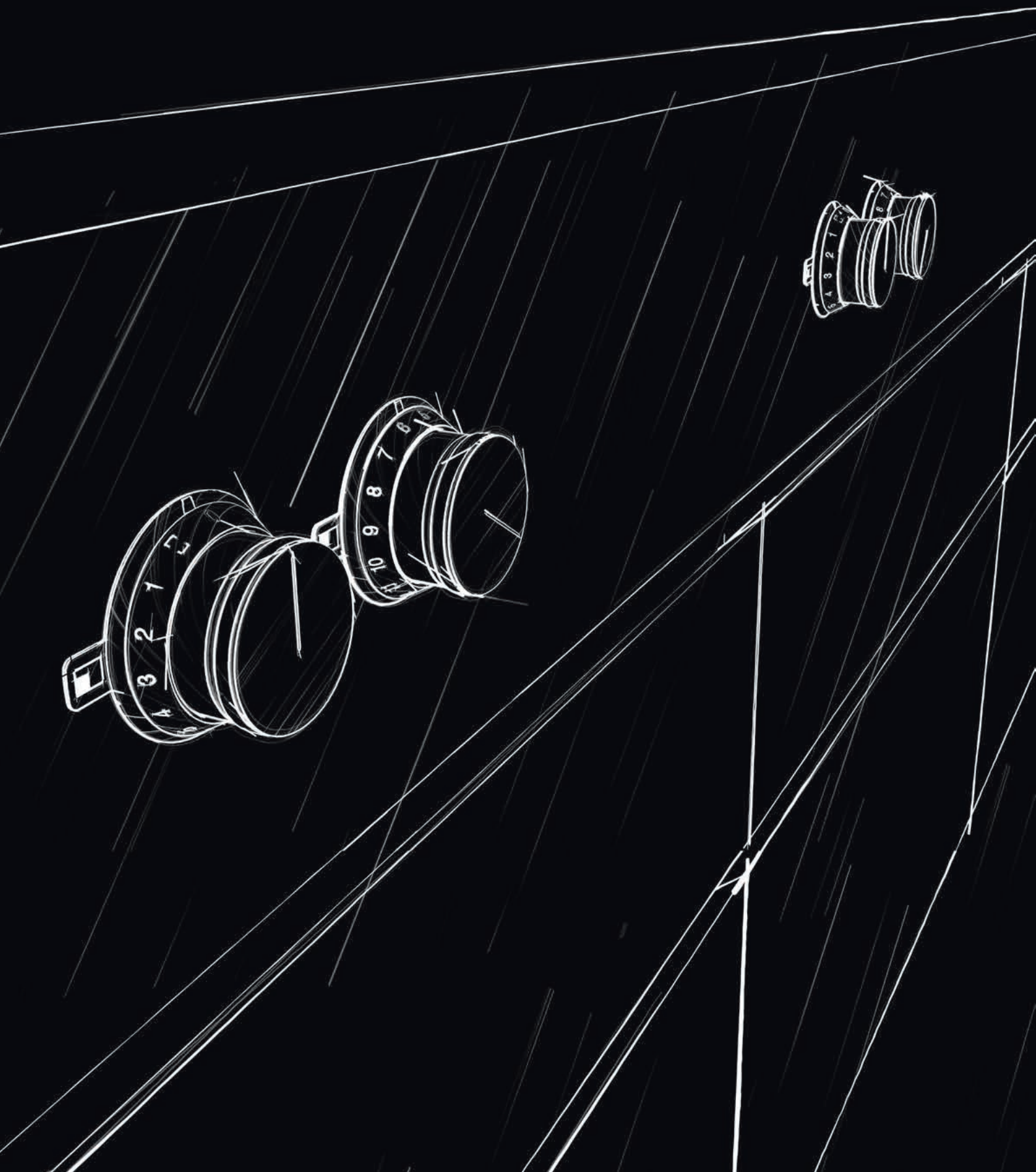

Energy Label | Home Connect | The accessories

Energy Label	410
Home Connect	411
Gastronorm system	412
Furniture handles	413

Energy Labels

By using energy-saving home appliances, you save valuable resources as well as money. That's why you should consider low energy and water consumption values when you purchase a home appliance.

Technological developments have resulted in many more products being able to attain an A+ or better rating. User behaviour has also changed, which is why new rescaled labels have been created that take this into account for washing machines, washer-dryers, dishwashers, cooling appliances and wine coolers. The Energy Label for ovens, cooktops and extractors will remain the same.

For more information on energy labels, visit: www.gaggenau.com

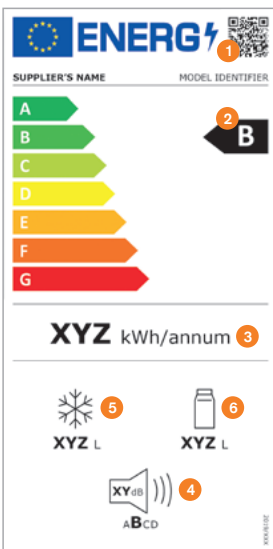

New rescaled energy label for washing machines, washer-dryers, dishwashers, cooling appliances and wine coolers.

Example Key for a fridge-freezer combination

- 1 QR code
- 2 Energy efficiency class
- 3 Energy consumption in kWh/year (measured under new standard conditions)
- 4 Noise emissions expressed in dB(A) re 1 PW and noise emission class
- 5 Total volume of all freezer compartments
- 6 Total volume of all refrigerator compartments

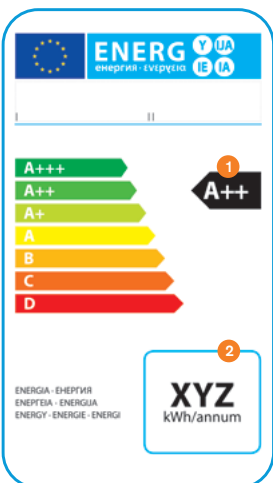

Energy label for oven, cooktops, extractors.

Key

- 1 Energy efficiency class
- 2 Energy consumption in kWh/year (measured under standard conditions)

The extraordinary is connected.

Make use of digital services via Home Connect.*



Discover how Home Connect can be used to enhance the chef's life and the appliances' use.

The difference is Gaggenau.

This is the beginning of the future of cooking. Aided by a digital device, the private chef can, for instance, preheat the oven, turn on ventilation, start the dishwasher, download digital user manuals and have a technician run a diagnostic check, all remotely.

Integrating into different home managements systems ensures the kitchen remains the heart of the digital home. The private chef can ask e.g. Amazon Alexa to prepare a cup of coffee and turn on the ventilation while checking remaining time of the oven.

- Connect:
Remotely control** and monitor. Enable remote diagnosis by an online technician.
- Access:
Download user manuals and utilise our partnering network.
- Integration:
Compatible with different home management systems.

This is just the start. Explore the possibilities at home-connect.com.

- 1 **Fridge-Freezer:** Control your energy consumption: change your appliances to Eco mode or Holiday mode via the App.
- 2 **Wine climate cabinet:** Using the App bring the chosen wine to serving temperature as you make your way home.
- 3 **Washing machine:** Communicating via Home Connect, the dryer chooses the programme best suited to the clothes the Washing machine has just cleaned.
- 4 **Oven:** Entertain in the garden and have your mobile phone alert you when the hors d'oeuvres are done.
- 5 **Fully automatic espresso machine:** Prepare your appliance for your morning coffee by turning it on with your mobile device.
- 6 **Combi-steam oven:** Send the sous-vide recipe settings (temperature, time and humidity) to your oven.
- 7 **Cooktop:** Rather than adjust the ventilation separately, link it through Home Connect and control it from the cooktop.
- 8 **Dishwasher:** Ask the app what setting would work best on your delicate glasses and heavily soiled pots and pans.

Download app here:



Apple App Store (iOS)



Google Play Store (Android)

* Home network integration for digital services (Home Connect) wireless via WiFi. The use of the Home Connect functionality depends on the Home Connect services, which are not available in every country. For further information please check: home-connect.com. Home Connect is a service of Home Connect GmbH.

** Not applicable for cooktops. Cooktops are not intended for unattended use – cooking process must be supervised.

The Gaggenau Gastronorm system

The Gastronorm system provides the basis for cookware in the professional kitchen. It enables a smooth continuum from the preparation and cooking stages right through to serving at the table and storage. The Gastronorm inserts from Gaggenau have been adapted to match our cooling appliances, our induction cooktops, our Combi-steam and steam ovens, our ovens as well as our dishwashers.



Prepare.

To prepare in combination with kitchen sinks in the Gastronorm format.

Keep fresh.

To keep fresh in Gaggenau cooling appliances.

Cook.

To cook on induction cooktops VI, CI and CX, in our Combi-steam and steam ovens BS/BSP or our ovens BO/BOP in combination with the pull-out system BA 018/BA 016.

Keep warm.

To keep warm in the Gaggenau warming drawers WS/WSP.

Regenerate/warm up.

To regenerate in our Combi-steam and steam ovens BS/BSP as well as warming up on our induction cook-tops VI, CI and CX or in our ovens BO/BOP in combination with the pull-out systems BA 018/BA 016.

Dishwashing.

Optimal cleaning and drying of the GN inserts thanks to the GN insert holder.

Accessories in the Gaggenau Gastronorm system

For usage in the various Gaggenau appliances the following accessories in the Gaggenau Gastronorm system are available.

Gastronorm insert

[GN 114/124/144/154](#)

These high-walled, sturdy inserts made from hygienic stainless steel are ideal for cooking with steam and equally practical for storage in the refrigerator or serving at the table. They are dishwasher-safe. For cooking several meals simultaneously, the cooking inserts for Combi-steam and steam ovens in the GN 2/3 format can be combined as required with smaller inserts that are available as special accessories in the GN 1/3 format.

GN 114 130

Gastronorm insert, stainless steel, GN 1/3, unperforated, 40 mm deep, 1.5l



GN 114 230

Gastronorm insert, stainless steel, GN 2/3, unperforated, 40 mm deep, 3l



GN 124 130

Gastronorm insert, stainless steel, GN 1/3, perforated, 40 mm deep, 1.5l



GN 124 230

Gastronorm insert, stainless steel, GN 2/3, perforated, 40 mm deep, 3l



Gastronorm roaster

[GN 340](#)

Gastronorm roaster in cast aluminium GN 2/3, height 165 mm, non-stick. For roasting in oven with roasting function. Lower and upper part can also be used as separate ovenproof dishes, height 100 and 65 mm. For ovens with heating element BA 056 115 or BA 058 115 and pull-out system BA 016 or BA 018 (both to be ordered separately) and for Combi-steam ovens with adapter GN 010 330 and pull-out system BA 010 301 (both to be ordered separately).

GN 340 230

Gastronorm roaster, cast aluminium, GN 2/3, height 165 mm



Teppan Yaki plate

[GN 232](#)

GN 232 110

Teppan Yaki plate made of multi ply material, GN 1/1
For full surface induction cooktop CX 492/482



GN 232 230

Teppan Yaki plate made of multi ply material, GN 2/3
For full surface induction cooktop CX 492/482



Furniture handles

For the individual design of your furniture fronts, Gaggenau is offering handle bars matching the Vario cooling appliances and also the 200 series ovens. Depending on the length, handle bars come with two or three mounts.

Handle bar with 2 mounts

GH 020 010

Handle bar, stainless steel,
Length 20 cm, height 49 mm,
drilling distance 177 mm.

GH 030 010

Handle bar, stainless steel,
Length 30 cm, height 49 mm,
drilling distance 277 mm.

GH 031 010

Handle bar, stainless steel,
match to BOP, Length 30.5 cm,
height 49 mm, drilling distance 282 mm.

GH 045 010

Handle bar, stainless steel,
Length 45 cm, height 49 mm,
drilling distance 427 mm.

GH 050 010

Handle bar, stainless steel,
Length 50 cm, height 49 mm,
drilling distance 477 mm.

GH 060 010

Handle bar, stainless steel,
Length 60 cm, height 49 mm,
drilling distance 577 mm.

GH 070 010

Handle bar, stainless steel,
Length 70 cm, height 49 mm,
drilling distance 677 mm.

GH 080 010

Handle bar, stainless steel,
Length 80 cm, height 49 mm,
drilling distance 777 mm.

GH 090 010

Handle bar, stainless steel,
Length 90 cm, height 49 mm,
drilling distance 877 mm.

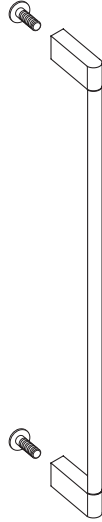

Handle bar with 3 mounts

GH 110 010

Handle bar, stainless steel,
Length 110 cm, height 49 mm,
Drilling distance 538.5 mm each.

GH 140 010

Handle bar, stainless steel,
Length 140 cm, height 49 mm,
Drilling distance 688.5 mm each.

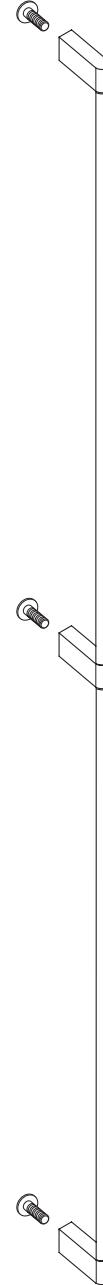

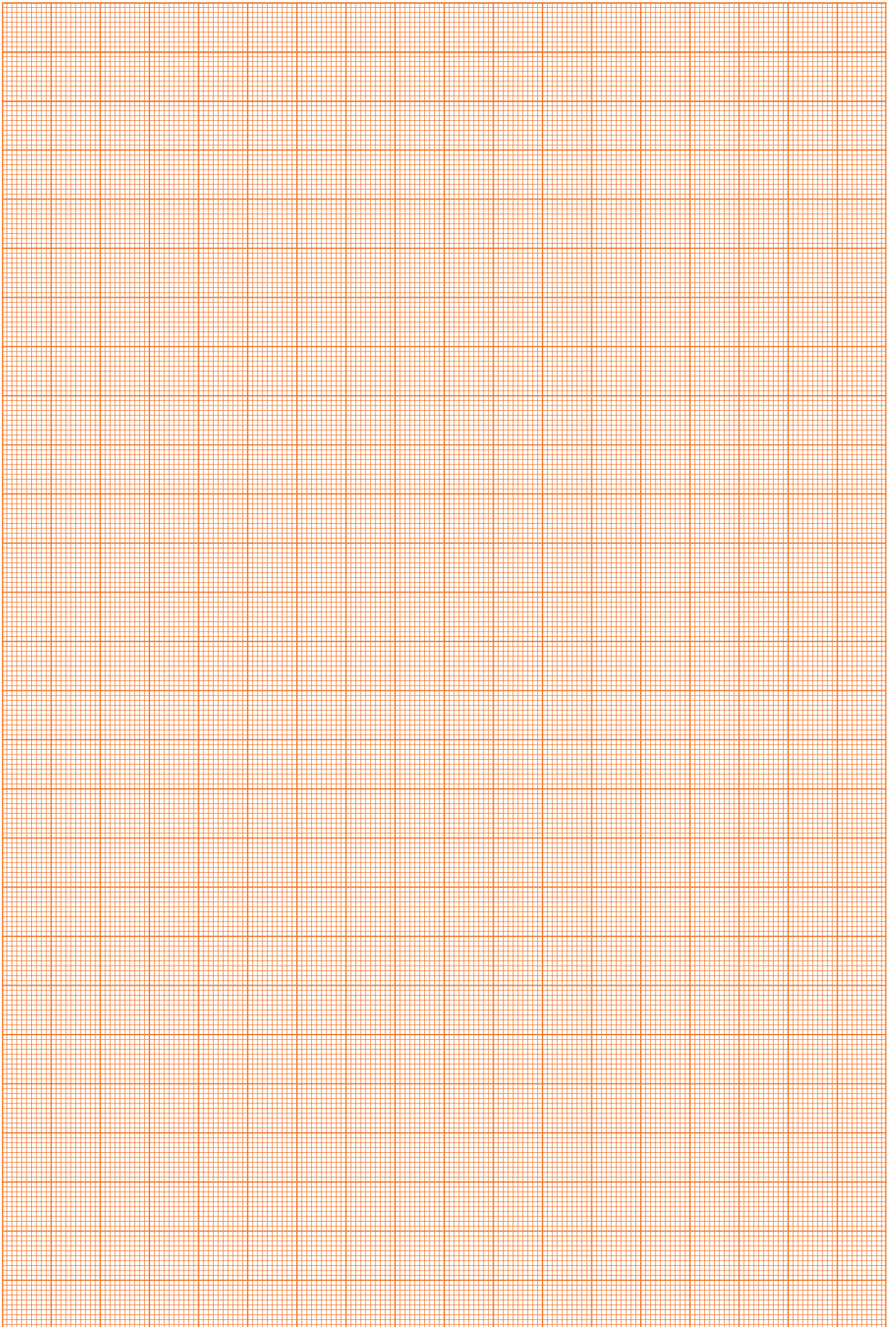

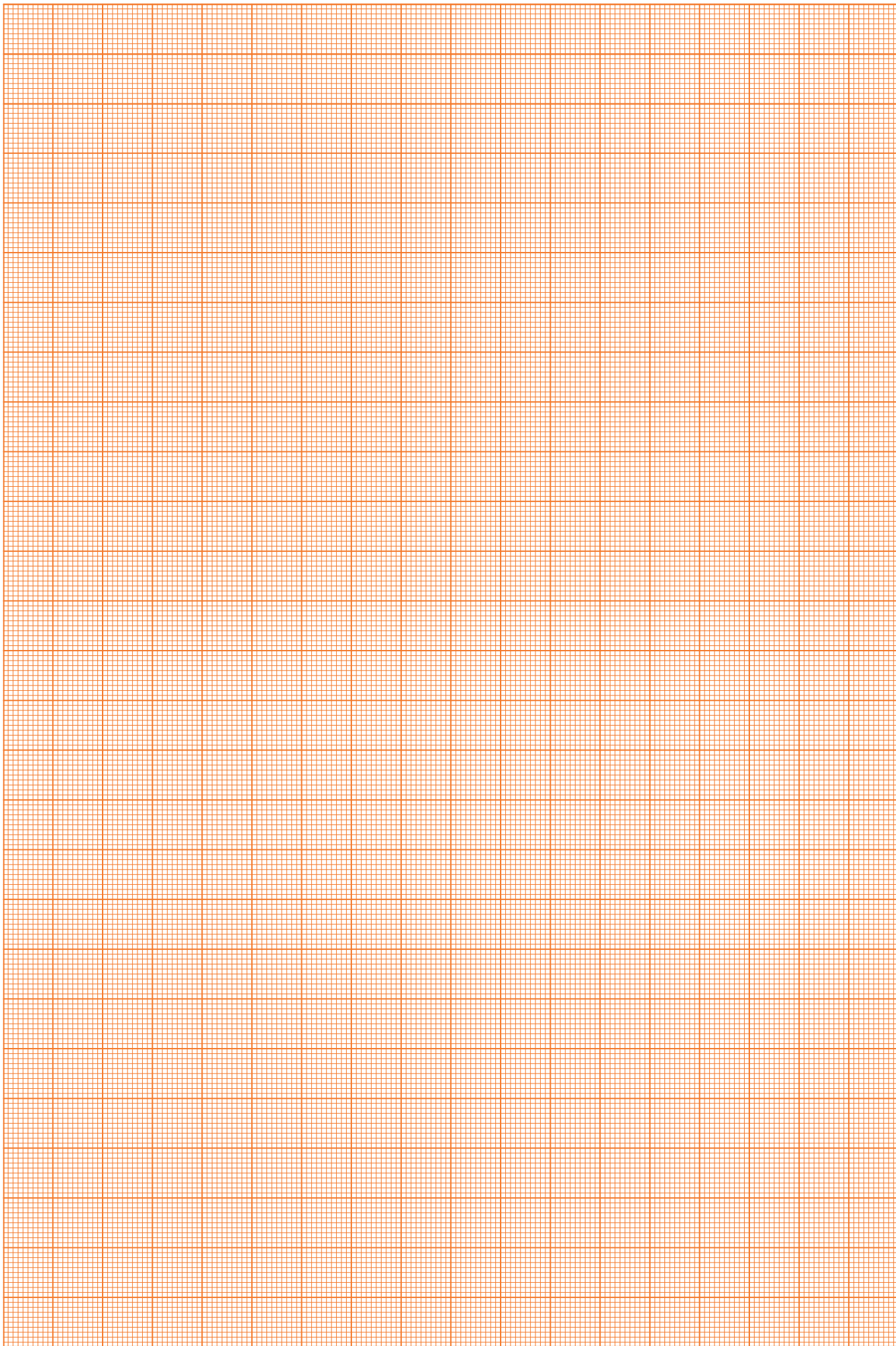

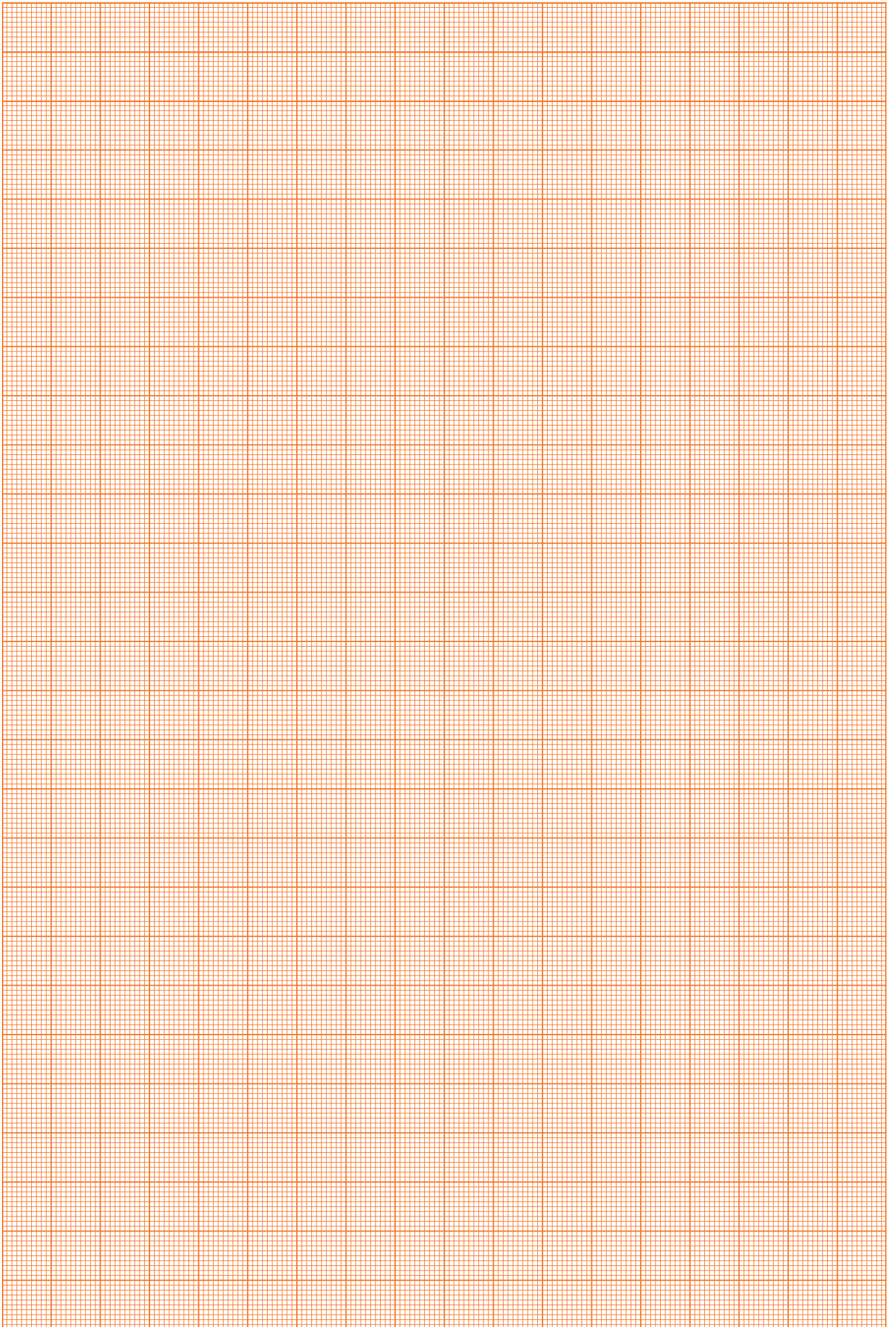

© Copyright by
BSH Hausgeräte GmbH
P.O. Box 830101
81701 Munich
Edition 2024 I.

The data and facts expressed herein are current as of November 2023. Gaggenau reserves the right to implement technical modifications that serve the purpose of progress.

The appliances are for household use only.

Certain appliances in this brochure are not available in all countries. Please contact your Gaggenau supplier for details.

The difference is Gaggenau.

www.gaggenau.com



09G1LF0035