

210mm

14,6 mm

210mm

The difference is Gaggenau.

GAGGENAU

Model numbers and specifications are for reference only and subject to change without prior notice. Prices are subject to change without prior notice. Please contact your local Gaggenau retailer for the latest information.

Valid from 1st January 2026

www.gaggenau.com



08G1LE0104

GAGGENAU

The range

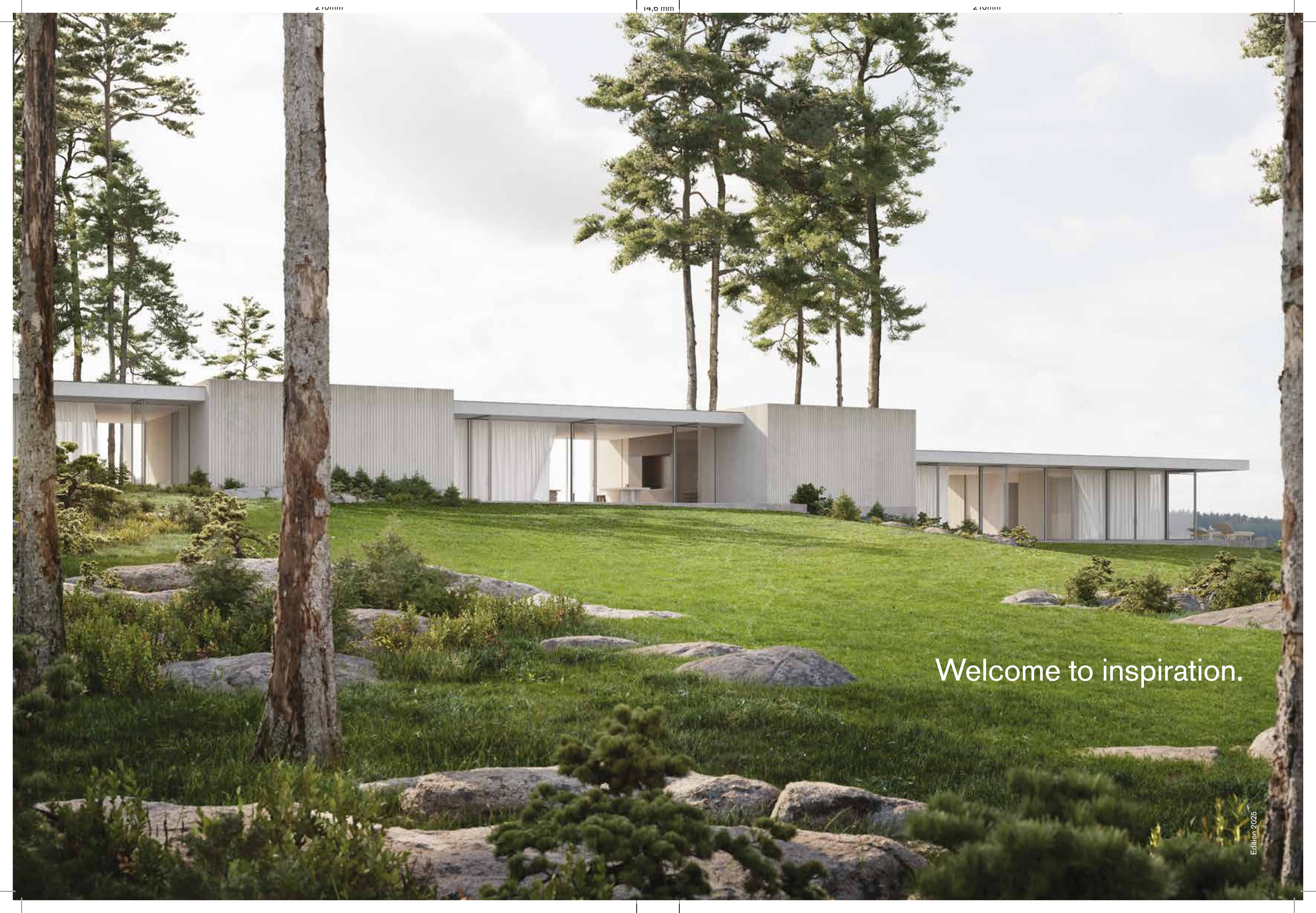

Welcome to inspiration.

Contents



47



5



33



91



7

Our story	1
Ovens	11
400 series	13
200 series	29
The EB 333	39
Cooktops and extractors	41
400 series	43
200 series	65
Refrigerators	81
The new generation of cooling	83
400 series	85
Wine cabinets	89
400 series	91
Dishwashers	95
200 series	99
Appliance overview	105
Home Connect	140
Showrooms	141

16 generations of heritage

1683, Ludwig Wilhelm von Baden, one of the most powerful aristocrats in Europe at the time, creates a hammer and nail forge in the Black Forest near the hamlet of Gaggenau.

Every hammer blow from that original foundry guides our metalwork today. Our heritage enables the continual creation of the exceptional, in every single appliance we craft and experience we provide.

1683

First nail emerges from the Black Forest

1880

The success of our enamel signs leads to ovens

1931

Launch of our electric ovens

1956

First built-in eye-level oven, separate cooktop & extractor

1972

Introduction of the Vario modular system

1976

First downdraft ventilation

1982

First flat kitchen hood

1986

Launch of our icon, the 90 cm wide EB 300 oven

1999

First combi-steam oven for the private kitchen

2011

First full surface induction cooktop with intuitive interface

2015

First automatic cleaning system for the combi-steam oven

2016

The EB 333. An icon, reborn

2020

Our Masterpiece, the refined combi-steam ovens

2021

Launch of the Vario refrigerators 200 series

2024

Launch of the Essential Induction & the new generation of cooling

The difference is...

Built by hand

After more than 300 years, we still handcraft much of what we produce. Every process, from shaping the initial sheet of steel to assembling our digital interface in our cleanroom, passes through a skilled craftsman's hands, with pride.

The professional kitchen principle

We take our cue from the professional's kitchen, where everything exists to serve the chef. Innovations that aid the chef are embraced and function is everything.

Quality in all things

Everything we do, is beyond the norm, from the materials we use, the craftspeople we employ to the quality control we are zealous about.

Discover the dedication to craftsmanship, heritage and performance on our website.

Experience Gaggenau

A global invitation

Join us to see, touch, hear, smell and taste the Gaggenau difference. We encourage you to visit, turn a control knob, gaze into an oven, discuss with our knowledgeable staff and push to open a fridge while sipping our espresso.

Artistic, cultural and culinary events are regularly hosted by showrooms, as are 'Respected by Gaggenau' exhibits, where local and global artisans and craftspeople show the commitment required to create the exceptional. Consider this your open invitation, simply book online or call your local showroom for your individual appointment, to feel the difference.



Bodegas y Vinedos Verum vineyard, Spain

Respected by Gaggenau

A tribute to the extraordinary

'Respected by Gaggenau' is our deeply-felt commitment to supporting like-minded artisans in the culinary, viniculture and design fields. Through the initiative, we have scoured the globe to unearth and showcase extraordinary farmers, producers and makers that strive for the best and who inspire and enable others. Such artisans share our ethos of making a difference by being masters in their field.

In the Culinary category, the family farm Salumi Bettella of Italy triumphed by cherishing their pigs and creating incredible Italian pork and cured meats. In the field of Viniculture, Spanish winemaker Elias López Montero is single handedly raising the reputation of La Mancha, with his traditional grapes and techniques. Apparatu, also in Spain, is the Design recipient, their utterly inventive ceramic designs straddle the world of craft, art and commerce.

Respected by Gaggenau is an ongoing, global initiative with local artisans often being celebrated in their native showrooms around the world.



Salumi Bettella



Elias López Montero



Apparatu

Discover more about our Respected by Gaggenau initiative on our website.

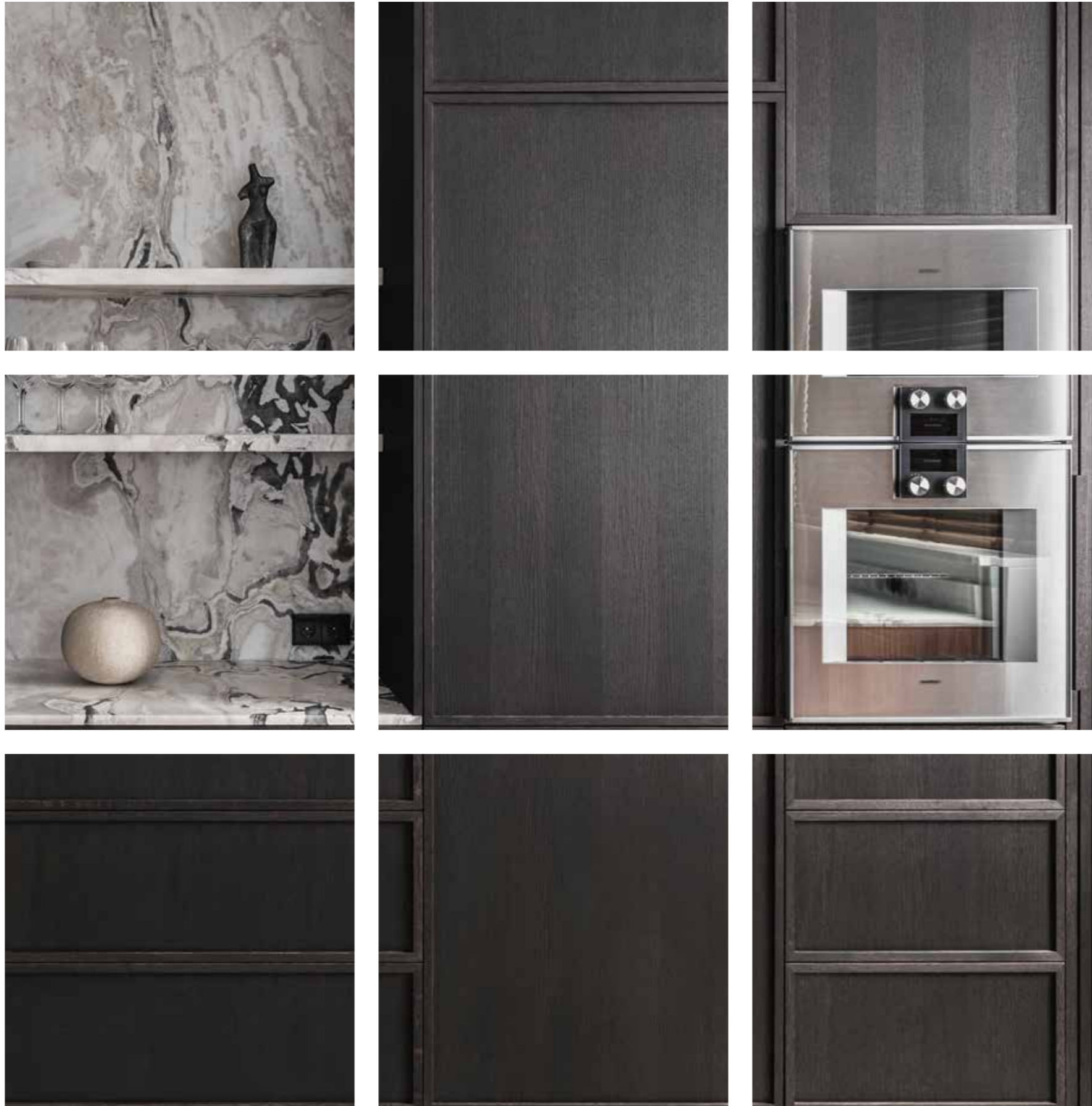

Join us online

Visit us on [gaggenau.com](https://www.gaggenau.com) and follow us by scanning the QR codes.



 [Gaggenauofficial](https://www.instagram.com/gaggenauofficial)



 [gaggenau_](https://www.pinterest.com/gaggenau_)



 [showcase/gaggenau/](https://www.linkedin.com/showcase/gaggenau/)



 [gaggenauofficial](https://www.youtube.com/gaggenauofficial)

Ovens

The epitome of culinary excellence,
the object of desire for the private
chef: the Gaggenau oven.

400 series
200 series
EB 333

Ultimately, the ovens 400 series are
the promise of culinary greatness.



Ovens 400 series

What the professional chef comes home to

The Gaggenau oven, combi-steam oven or combi-microwave oven is an aspiration for many, a promise to guests, a calling for the private chef and a statement to the designer. Inspired by the professional kitchen, it offers a considerable number of advantages, such as being hand crafted from the finest materials, ovens offering 300 °C capability and heated air catalysts to remove grease and odours. Every Gaggenau oven is made for the keen private chef while being designed for the private home.

A stainless steel backed full glass makes a statement in any kitchen.

Oven, fully automatic espresso machine, combi-steam oven and culinary warming drawers 400 series

The luxury of exceptional capability

Cook with intense heat, without feeling it

Each of our 400 series ovens will more than satisfy the most demanding of chefs, with reassuring professional characteristics at every turn.

The distinctive solid stainless steel rotary knobs and TFT display provide intuitive control over the 17 cooking functions.

Touch the screen and the handleless door that sits proud of the surface, calmly opens, as much as 180° wide. Four layers of glass ensure a cool door regardless of internal temperature, even during the 485 °C pyrolytic cleaning programme. Each layer of glass perfectly renders colours, allowing you to accurately judge the browning of dishes, which can be achieved evenly using the rotisserie spit.

The 3-point core temperature sensor measures precisely the temperature and revises the cooking times as the dish is cooking, automatic programmes assist the private chef while the convenience of Home Connect allows you to control and monitor it remotely. In every sense of the word, this oven is proud.



Automatic cleaning system

Fully master the power of steam

Create your masterpiece

Having introduced steam into the private kitchen over twenty years ago, we have relentlessly refined it. The latest combi-steam ovens, available connected to a fixed water supply or using tanks, offer an enlarged cavity with which to master the culinary style.

Our private chef assistance with adjustable automatic programmes, five humidity levels, and up to 230 °C alongside a full surface grill behind glass encourages you to perfect your steaming. In short, it not only steams, but braises, bakes, browns, grills, gratinates, regenerates, sous-vides and even extracts juice. After which, it cleans itself using its sophisticated automatic cleaning system and its own water supply.



Water tanks



Vacuuming drawer 400 series

Making steam a pleasure

Cooking with nuance

As your masterpiece is being created, ensure it is beautifully illuminated. Discreet LEDs bathe your dish in soft white light, without glare thanks to a non-reflective back wall. Another thoughtful touch is the condensing of excess steam, simply to ensure the private chef is not engulfed in a billowing cloud when opening the door.

Steam adores a vacuum

Add the vacuuming drawer under your oven or counter, in the same design as your oven or kitchen furniture, and sous-vide might almost become your convenience food. With different vacuum levels and sizes of bags, you will be able to lock in flavours, preserve ingredients and marinade in a third of the time. With the ability to vacuum outside of the drawer you can also enjoy opened wine even after the following night.

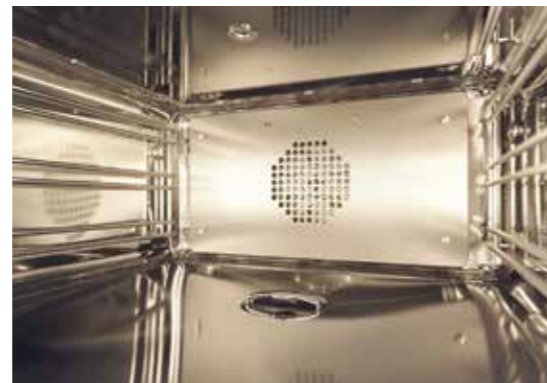

Glare-free illumination



60 cm combi-steam oven 400 series



Baking stone



Multiple core temperature probe

The accoutrement of baking

Within the oven

The core temperature probe is more than a thermometer for meat, fish, bread or dough. The readings from the inside of the dish will enable the oven to regulate its temperature and continually adjust its timer, giving you an up dated cooking time.

Accessories can unlock an entire culinary potential: the baking stone's intense heat is the secret ingredient for crisp tarte flambée, pizza bases and bread, there really is no alternative to cooking directly onto 300 °C.

Extendable rails, Gastronorm roasters and inserts as well as variable trays and pizza paddles will complete your oven's abilities, and yours.

Watch our films of the ovens 400 series on our website and YouTube channel.



Gastronorm roaster

Fully automatic espresso machine 400 series



The coffee machine

Your coffee, perfected

Water is kept consistently heated throughout the coffee brewing process, releasing the aroma while avoiding the bitter compounds. The insulated milk container is automatically weighed and will alert you if there is insufficient milk (or milk alternatives) or if you should check it for freshness.

A multitude of beverages can be made, including 12 types of coffee with up to 8 personalised options. Adjust the size, temperature, strength, milk to coffee ratio and number of cups to make a coffee, yours.



Oven, fully automatic espresso machine, combi-steam oven and culinary warming drawers 400 series



Currently not available in India



Fully automatic espresso machine and culinary warming drawer 400 series

The culinary warming drawer



29 cm tall culinary warming drawer 400 series

Your new favourite appliance

The culinary warming drawer is an exceptional slow cooker, comfortably accommodating all the Gaggenau oven accessories. Stable, low heat of up to 80 °C is distributed evenly for slow cookery, proofing dough, drying herbs and fruits, defrosting, melting chocolate and maturing yoghurt. Simply choose between preinstalled programmes for slow cooking, food warming and the heating of cups & plates or determine the temperature yourself. The Home Connect function further expands the drawer's repertoire, allowing the user to set a timer, add a favourite setting to the drawer's control panel and access additional programmes and exclusive recipes.

Where would you like it?

Versatile in use and placement, your culinary warming drawer can be installed beneath or alongside other appliances, or separately, as well as in your choice of Gaggenau finishes. The drawer can even be placed under countertops, in your kitchen furniture fascia.

Flush or surface-mounted ensures the oven 200 series fits into any kitchen concept.

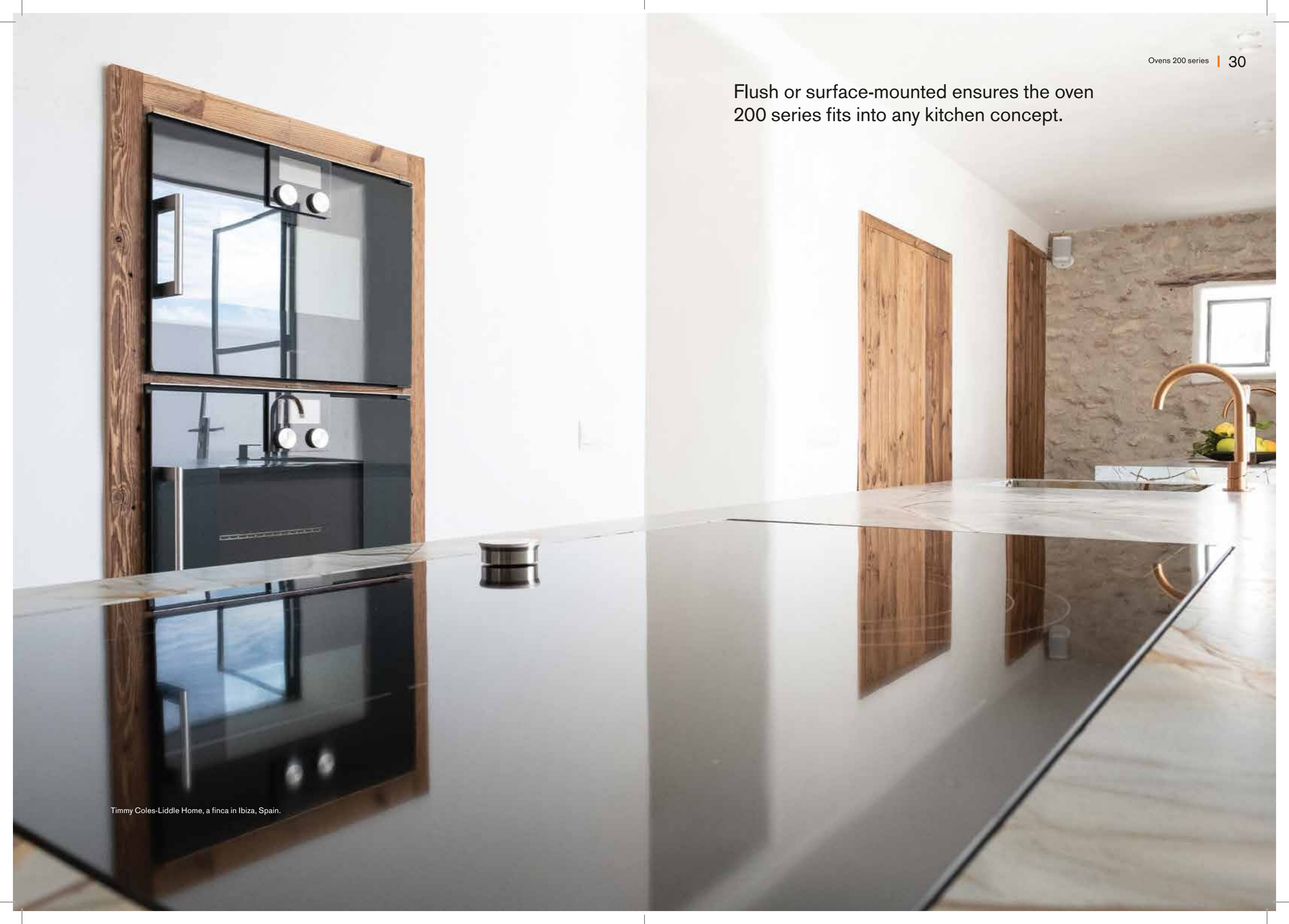

Ovens 200 series

A matter of taste

A more subdued aesthetic defines the 200 series: it sits flush to the surface, its handles match those of your refrigerators 200 series, it does not dominate, yet it promises all the culinary prowess that the ambitious private chef could hope for. The ovens also utilise the distinctive solid stainless steel control knobs and TFT display. From here you control up to 13 heating methods, up to 300 °C and the baking stone ability, for baking as intense as a brick oven. Home Connect enables remote control and diagnosis and is available in most appliances.

Every oven 200 series, combi-steam and combi-microwave, culinary warming drawer and vacuuming drawer is available in Gaggenau Anthracite.

Oven, fully automatic espresso machine,
combi-steam oven and culinary warming drawers 200 series



Oven, fully automatic espresso machine, combi-steam oven and culinary warming drawers 200 series



Combi-steam oven 200 series

Master steam

Don't just add steam to your repertoire, master it

Our latest combi-steam ovens are almost as much of a revelation as our original, the first for the private kitchen. In the intervening two decades we have evolved the combi-steam to its current state of perfection, allowing you to steam, braise, bake, grill, gratinate and sous-vide.

The 200 series offers a choice of fixed water connection with automatic cleaning system or easy-access, large water tanks. An enlarged, beautifully-lit cavity with a full surface grill under glass, chef assistance and adjustable automatic programmes with five humidity levels enable you to master steam.

The vacuuming drawer – for more than sous-vide

The perfect complement to your combi-steam oven, you can add the vacuum drawer beneath the worktop or the oven, in either your kitchen furniture or same design as the oven. With multiple vacuum levels, bag sizes and an attachment for use out of the drawer, the vacuuming drawer encourages you to lock in flavours, speed up marinating as well as preserve ingredients and opened wine.

Oven, fully automatic espresso machine and culinary warming drawer 200 series



Fully automatic espresso machine and culinary warming drawer 200 series



The coffee machine

Be your best Barista

Brew up to 12 types of coffee, and have the machine remember 8 personalised options, adjusting strength, temperature, amount of milk and coffee and number of cups. Make other hot water and milk drinks easily, the insulated milk container is even situated on a weighing scale, allowing the machine to warn you if the milk is running too low to make your choice of beverage.

At every stage of its preparation, your coffee's water is kept at a constant temperature, to release the aroma but not the bitter compounds.

Explore more on our website about our coffee machine 200 series.

Culinary warming drawer 200 series



The culinary warming drawer 200 series

The slow cooker in a drawer

This is a drawer that slow cooks, proofs, dries, defrosts, gently melts and matures using a consistent, stable heat up to 80 °C. Four programmes allow you to easily choose between slow cooking or the warming of food, cups or plates, or simply pick your own temperature. The drawer even holds any of the Gaggenau baking or steam accessories, allowing a seamless transition between oven and drawer. The Home Connect app opens up even more possibilities, with a timer, recipes and the ability to programme the drawer with your preferred setting.

Place your warming drawer under, alongside, separated from other appliances or integrated under a countertop in your kitchen furniture fascia.



Fully automatic espresso machine, combi-steam oven and culinary warming drawers 200 series



The EB 333, our 90 cm oven

The oven EB 333

Cook with an icon

This is a culinary icon, and has been for over 30 years. The entire front, all 90 cm of it, is the door, coming in at 20 kg thanks to five layers of glass keeping the outside cool while the inside is a raging 300 °C. Hand-crafted from a single sheet of 3 mm thick stainless steel, the door is cleverly cantilevered to gently close and easily open while the glass is carefully formulated to insulate without distorting colours, allowing you to see exactly how the three chickens on the rotisserie spit are progressing.

The EB 333 is the professional chef's final aspiration, the level of craftsmanship required to make it is such that daily production rarely exceeds single figures, something you will appreciate as you enjoy it decade after decade.

Watch the award winning EB 333 film and interviews on YouTube and our website.

Cooktops and extractors

Gaggenau cooktops and extractors do not just look the part; designed with performance, discretion and aesthetics in mind, they are inspired by the professional kitchen.

400 series
Vario 400 series
200 series
Vario 200 series



The cooktops and extractors 400 series adhere to the Gaggeneau principle of exceptional materials, designed with insight and assembled with skill by craftspeople.

Cooktops and extractors 400 series

Cook, ventilate, entertain

As the kitchen becomes the new entertainment centre, cooktops must appeal visually and efficient ventilation becomes more vital. Cooktops and extractors are intrinsically linked in your kitchen.

For those with a spacious kitchen, our 400 series offers the aesthetically pleasing 90 cm induction or a full metre of gas with which to be creative. The modular Vario cooktop options: induction, gas, Teppan Yaki, electric grill and downdraft ventilation connect into one cooking area.

To remove distractions, and avoid becoming one, our extractors use quiet motors. Choose from the minimalist table and downdraft, modular Vario ceiling or wall-mounted hood statement pieces.

Explore the 400 series at [gaggenau.com](https://www.gaggenau.com)



Full surface induction cooktop, table ventilation and Teppan Yaki 400 series



Full surface induction cooktop 400 series



Full surface induction cooktop 400 series

The full surface induction cooktop

For those of unlimited imagination

The full surface induction cooktops represent 80 cm of flush- or surface-mounted limitless creative space. Unconstrained by any white lines, the black glass is absolute in its devotion to minimalism. Beautiful alone, perfect when coupled with our modular Vario cooktops, they offer freedom for the kitchen designer and flexibility to the chef: up to five or six pans can be placed anywhere on their perfectly black surface. Move the pans around, the heat and timer settings follow. Add the Teppan Yaki accessory or utilise the Professional cooking function, which allows you to move the pans between different pre-set temperature zones without touching the controls.

The large TFT touch display invites you to intuitively scroll through the 17 power levels, timers or even compatible extractor settings using its Home Connect ability.

Explore the full surface induction cooktop at [gaggenau.com](https://www.gaggenau.com)

Illuminated black control knobs



Control and installation

Total, subtle, control

The illuminated 400 series controls, in your choice of finish: stainless steel or black, show which cooking zone is in use or cooling down. They can be installed on the front of the worktop – to hand, without distracting the eye, just as in the professional kitchen. Alternatively, the full surface induction cooktop 400 series offers the private chef a large touch display to scroll through their many options.

Consider placement

Many cooktops offer surface or flush mounting in any favoured configuration. Either a visible, 3 mm-thin stainless steel frame sits upon the worktop or the cooktop is embedded into the worktop, the choice is yours.



Surface mounting



Flush mounting

Explore more at [gaggenau.com](https://www.gaggenau.com)

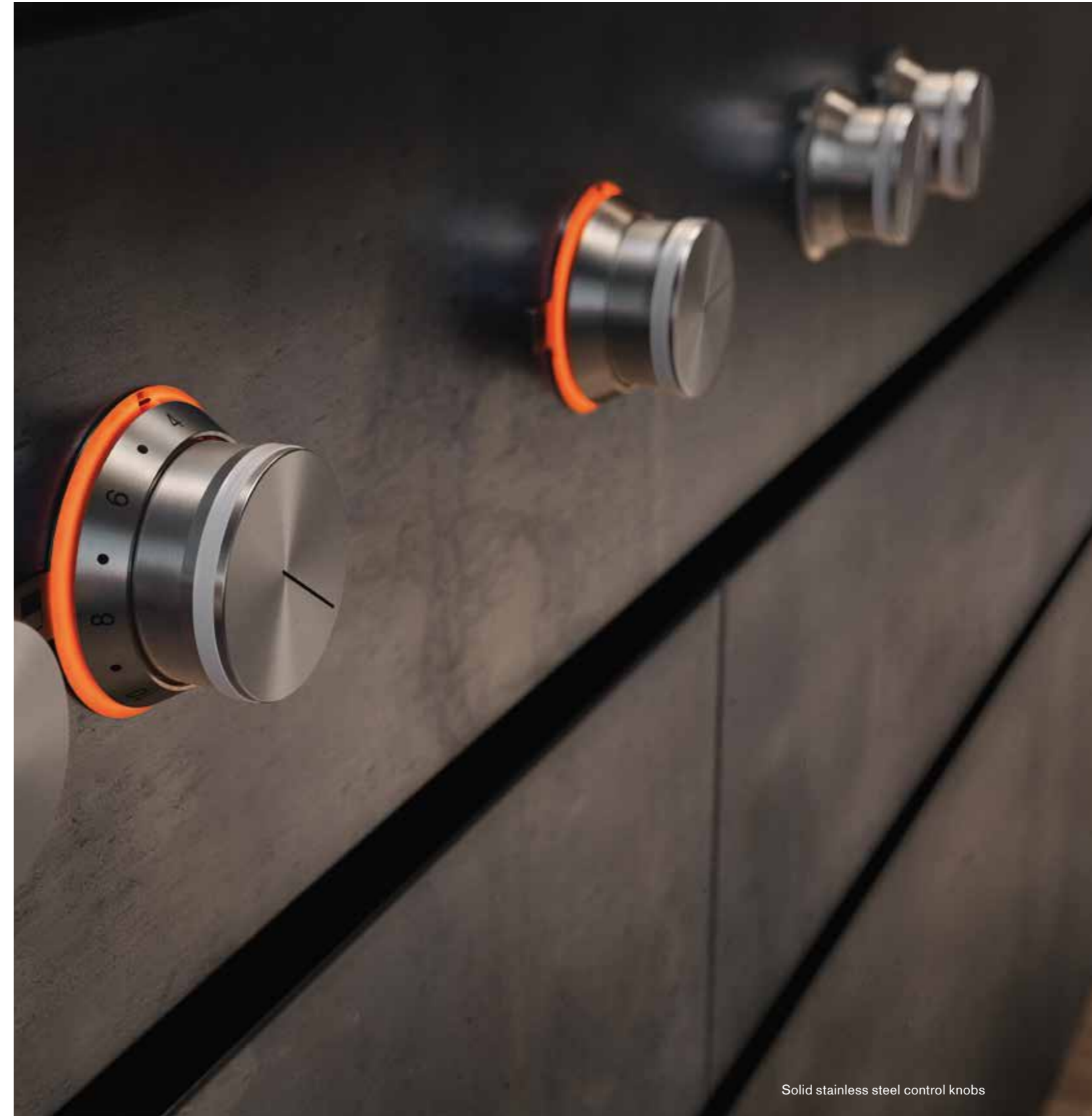

Solid stainless steel control knobs



Table ventilation, Vario gas wok, gas cooktop and Teppan Yaki 400 series

Clearing the air, at source

The addition of unseen extraction

The table ventilation rises regally from the island behind the cooktop, capturing the vapour and odours while directly illuminating the worktop. Having accomplished its task, it sinks back down level with the surface.

The table ventilation draws steam and vapours down, at source, before they pervade the atmosphere. The quiet fan and space-saving ducting ensure discreet efficiency of the downdraft far in excess of its minimal size.



Wall mounted hood 400 series

The rise and removal of vapour

Extraction, or circulation, from above

The Vario ceiling ventilation is a modern, modular and integrated solution. Its flush, minimal profile houses dimmable lighting, filters and ducting with the quiet brushless motors situated externally, out of sight and earshot.

Alternatively, make more of a statement with our wall-mounted hood: 120 cm of stainless steel. Three power levels, an intensive and automatic function as well as large angled baffle filters ensure removal of vapour.

All offer highly effective air extraction or circulation.

Explore the extractors 400 series at [gaggenau.com](https://www.gaggenau.com)

Vario ceiling ventilation 400 series



Gas cooktop 400 series

The full power of gas

Gentle warmth, immense heat, total control

Handcrafted using the highest quality materials of stainless steel, brass and cast iron, this is the cooktop for the demonstrative chef who needs the space to wield multiple pans. It stretches out for a full metre, flush to the surface and can even be welded into a 3 mm stainless steel worktop. Beneath cast iron supports, a large central wok or paella burner is surrounded by two high power and two standard burners, all brass.

Full electronic power level regulation provides precise and reproducible flames, by turning the gas on and off it allows the gentlest of simmering and at full power enables wok and flash frying. When dealing with up to 18,000 watts of heat, direct control is important.

Explore the gas cooktop 400 series at gaggenau.com



The Vario cooktops and extractors 400 series combine to not only empower, but also inspire, the creative private chef.

Vario cooktops and downdraft 400 series

Create your creative space

The modular Vario cooktop range inspires the private chef to create their bespoke workstation, one that suits their way of cooking and advances their ambitions. The chef can build a modular, surface- or flush-mounted worktop, from induction, gas, Teppan Yaki and electric grill options, all of which can be interspersed with the downdraft to remove vapour at source. Professional, solid illuminated control knobs, in stainless steel or black, with or without a 3 mm thin stainless steel frame, ensure the array of appliances are an aesthetic success.

Protect your creative space from vapour. Provide adequate ventilation via cooktop level extractors, such as the downdraft or table ventilation, and overhead extractors such as the wall-mounted hoods or modular ceiling ventilation.

Explore the Vario 400 series at [gaggenau.com](https://www.gaggenau.com)



Vario configuration: induction, electric grill, Teppan Yaki, gas cooktop and downdraft ventilations 400 series



Vario configuration: gas cooktop, flex induction, Teppan Yaki and downdraft ventilations 400 series



Vario configuration: flex induction, downdraft ventilation, Teppan Yaki 400 series and socket

Vario cooktops and downdraft 400 series

Induction or gas? Both

All Vario cooktops can be installed flush-mounted. Everything from the 15 cm downdrafts, 38 cm single cooktops such as induction wok, Teppan Yaki, electric grill, through to a 90 cm five cooking zones induction offering a large triple ring for woks or larger pots as well as combinable heating areas.

The gas burners place up to 6,000 watts of raw power at your disposal. Fully precise electronic control over the flame enables the gentlest simmering and the fiercest of flames, which automatically re-ignite if they are blown out. The 38 cm single wok or paella burner is all consuming with several flame rings in one burner, alternatively you can extend to 90 cm and five brass burners.

Explore the Vario configuration at [gaggenau.com](https://www.gaggenau.com)

Vario configuration: gas wok, gas, Teppan Yaki, electric grill, flex induction 400 series



Tailor your culinary scenario

Choose something special

The electric grill and Teppan Yaki are specialist appliances. Both have two cooking zones, enabling simultaneous heating and warming on a single surface. Alternatively, roast and grill together by replacing one half of the grill with a roasting pan.

Since its innovation in 1976, our downdraft ventilation has been performing quietly, invisibly, clearing the air for over four decades. Utilising the same stainless steel or black control knobs as the cooktops, the downdraft blends in as it draws steam and odour down into the worktop before they offend the chef.

Explore the Vario configuration at [gaggenau.com](https://www.gaggenau.com)



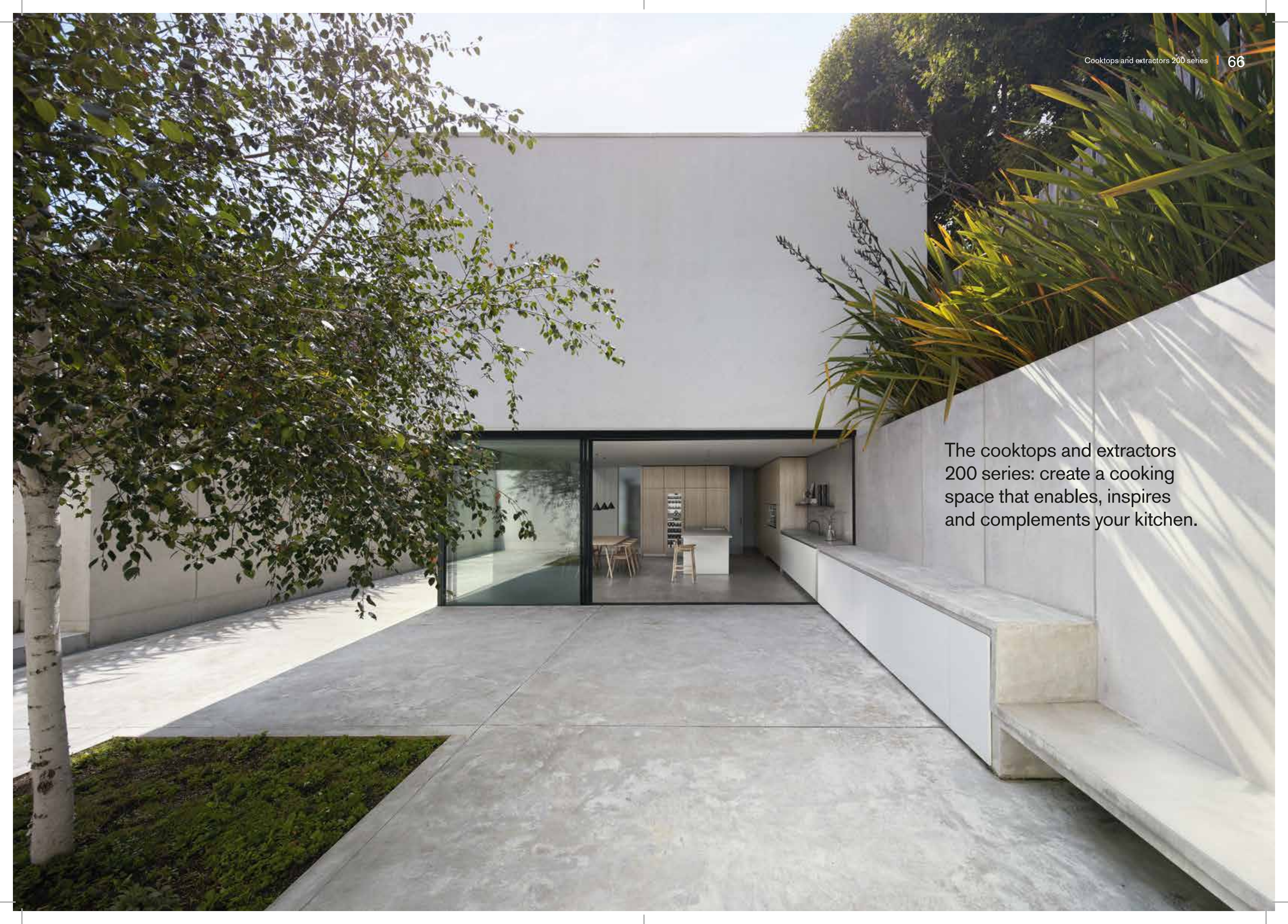

The cooktops and extractors 200 series: create a cooking space that enables, inspires and complements your kitchen.



Controls and installation

Control of choice

The 200 series offers two control mechanisms. The Vario range's orange illuminated control knobs are integrated into the cooktop itself. The gentle illumination indicates when the appliance is on, heating up, at the correct temperature or cooling down.

The bi-coloured display ensures clear communication of the cooking zones in use as well as the cooktop power levels. Home Connect enabled, the cooktops can also control compatible extractors.

All flex induction cooktops can be installed with or without frame.

| Explore more at [gaggenau.com](https://www.gaggenau.com)



Black control panel and illuminated control knobs

Ceiling ventilation

Extraction from above

The integrated Light Bronze rim extractor lies flush, within the ceiling, recirculating or extracting the kitchen air. Quiet and discreet, the Light Bronze blends in with lighter ceiling tones, offering greater flexibility for the designer and mastery over their environment for the chef.

Easy to operate, one can activate it via the remote control, cooktop-based ventilation control or through Home Connect. Automatic operation, whereby air-quality sensors detect when to ventilate, is also a convenient option.

Explore the ceiling extractors 200 series at [gaggenau.com](https://www.gaggenau.com)



Ventilation as a statement

Centrepiece of the kitchen

The wall mounted hood is impressive. Contained within the stainless steel and Gaggenau Anthracite glass frame lies the recessed filters, low noise fan and adjustable lighting. Fully illuminate a busy cooktop, change the tone or dim to set the mood, artfully. Able to circulate or externally vent the air using dishwasher-safe grease filters and activated charcoal filters, their design ensures they capture more vapour at lower power and noise levels. They can be controlled manually, set to automatic: adjusting themselves depending on the fumes detected.

Explore the extractors 200 series at gaggenau.com



Island hood 200 series



Flat kitchen hood 200 series



Hidden extractors

Discreetly effective

The flat kitchen hood is an intelligent, space-saving solution, sitting within the confines of a 60 cm or 90 cm width niche. Invisible and quiet, it provides dimmable lights, three power levels, automatic function and glass screen, extends beyond the cupboard when needed.

The quiet motor can be completely enclosed within the kitchen furniture while the easy-to-clean glass cover and dimmable illumination are all encased in stainless steel, hidden from view.

Explore the extractors 200 series at gaggenau.com

Gas cooktops

Aspirations achieved

There are three gas cooktops in the 200 series, presenting you with a choice of size and aesthetic. They vary from 60 cm for the four burner cooktop, to 90 cm for the five brass or black burner options. Stainless steel controls place the nine mechanically regulated power levels at your disposal.

These are cooktops designed to be both simple to use and be fully capable of creative, professional cooking.

Explore the gas cooktop 200 series at gaggenau.com



For the private chef with professional tastes. The 200 series.



Vario cooktops and extractors 200 series

Grand culinary ambitions, enabled

The range of Vario options enables a truly bespoke, personalised kitchen. As much about aesthetics as scale, the Vario 200 series distinguishes itself through its anodized aluminium, black control panels incorporated into the cooktops and uniform rectangular shape of the Vario appliances.

For the gas-centric chef, mechanically controlled power regulation precisely controls the nine levels of heat, ensuring replicable results.

Aspiration, circulation and extraction

Since 1976, our downdraft ventilation has quietly outperformed its small size. Our current 15 cm wide model is able to extract or circulate, automatically if preferred. Larger extractors in the 200 series include wall-mounted and island hoods, ceiling ventilation, flat kitchen hoods tucked into kitchen units and the invisible canopy extractors. There is a 200 series option that complements your kitchen.

Explore the Vario configuration at gaggenau.com



Vario flex induction and downdraft ventilation 200 series



Vario configuration: gas cooktop, flex induction, Teppan Yaki and downdraft ventilations 200 series

Refrigerators

Extending the freshness of your ingredients and presenting all in its best light.

The new generation of cooling
Vario 400 series



The pinnacle of cooling.
Introducing the new generation.

*Currently not available in India

Vario refrigerators 400 series

Modular, seamless, impressive

A fully integrated, built-in modular family: the Vario cooling 400 series refrigerators, freezers, fridge-freezers and wine climate cabinets can be partnered in a multitude of ways. You have the flexibility to create an impressive, stainless steel clad, elegant cooling wall, with or without handles. Alternatively, the handleless options are able to disappear discreetly behind your kitchen furniture.

The Vario cooling 400 series is reduced to the essence of pure refrigeration and an impressive design interior. You gently push the enormous door and it effortlessly opens to a professional-grade stainless steel interior with modern, anthracite aluminium elements and almost imperceptible clear glass shelving.

The minimalist internal aesthetic is accentuated by warm white, glare-free spotlights that dramatically and flatteringly illuminate your all-important ingredients.

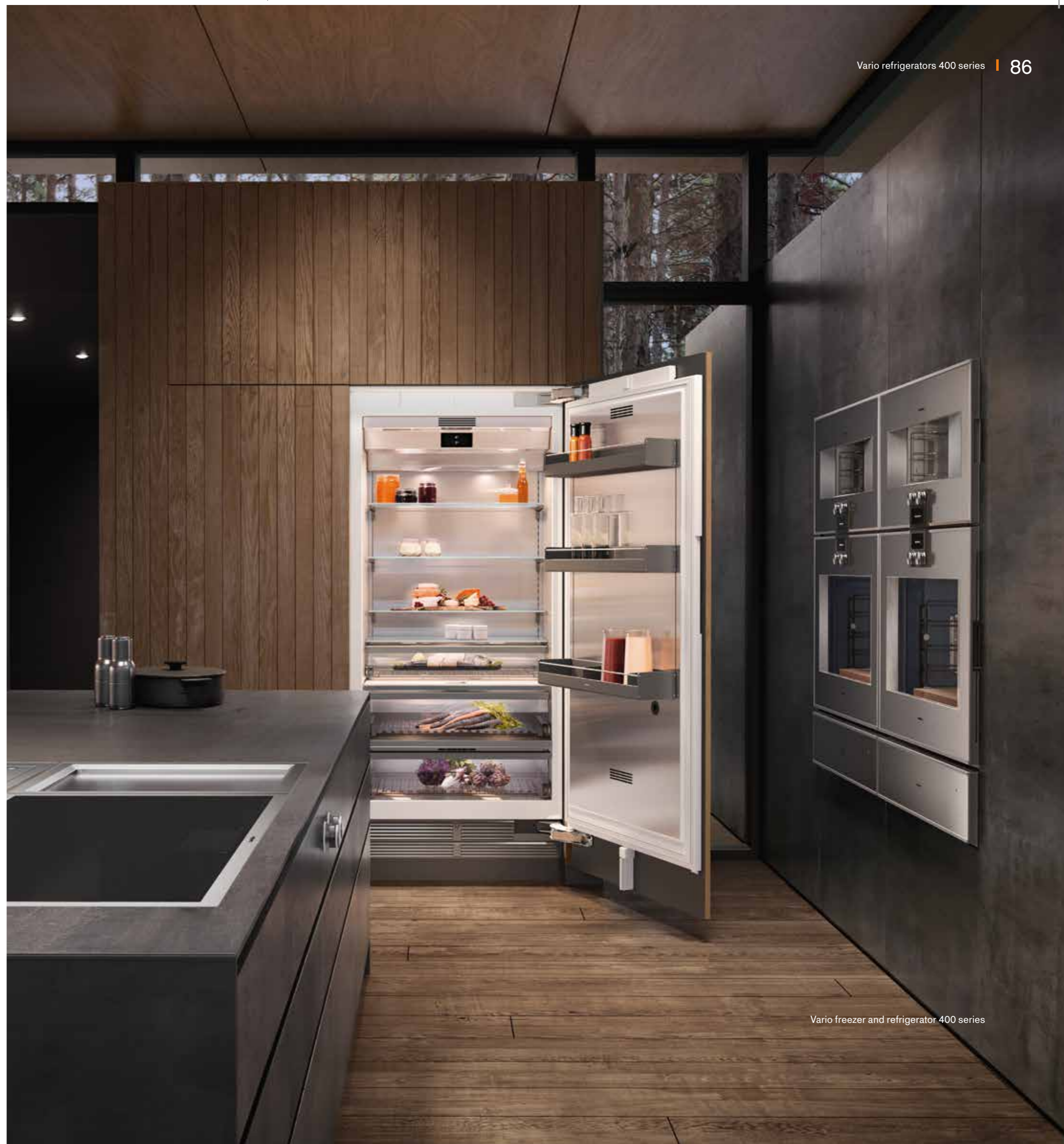



Vario refrigerator and freezer 400 series



Fully extendible freezer drawer and warm white, glare-free LED lights

Effortless access to fresh ingredients

Push to open and...

The two opening assist options allow even the largest and heaviest of doors to be opened effortlessly, either by pulling or, for the handleless option, with a gentle push.

As you would expect, cooling is accurate to within a degree. Ideal storage conditions are met inside the cooling drawer, preserving your meat and fish for longer, thanks to temperatures close to, or even at, 0 °C.

Utilising the same TFT touch display as our ovens ensures you can effortlessly navigate the system, alternatively, you can control temperatures remotely via Home Connect.

To produce a reduced, pleasingly uniform, appearance: the easily adjustable, near invisible, rail system, allows those so inclined, to align the height of the shelves and solid aluminium door bins of their refrigerator and freezer.

Watch our Vario refrigerators 400 series film on our website.



Solid anthracite anodised aluminium door racks



Wine climate cabinets

Protect, present, prepare.

Vario 400 series

A wine climate cabinet that preserves your wines under precise temperatures, showcases your collection and enhances the prestige of your kitchen.

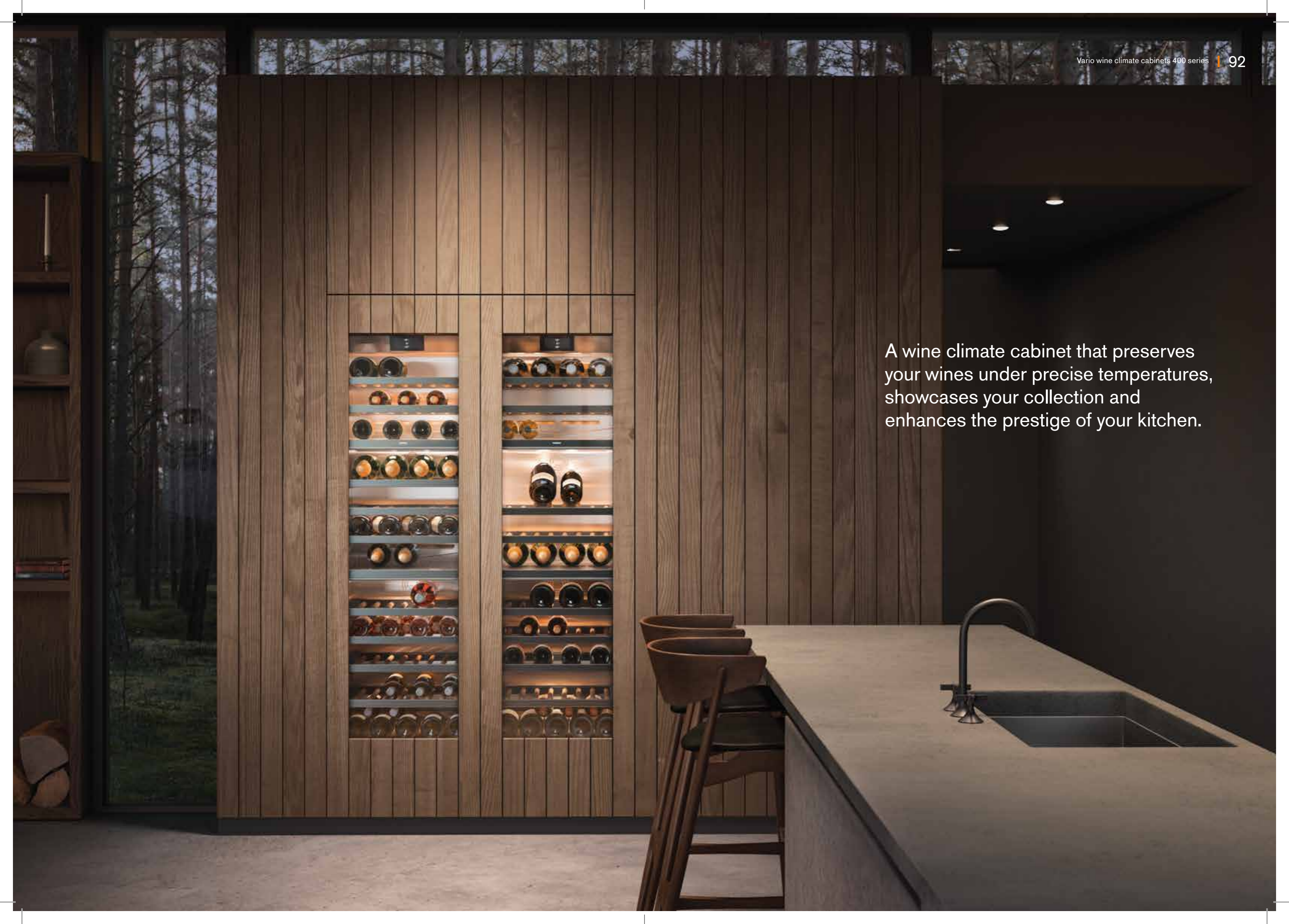

Vario wine climate cabinets 400 series

Protect and serve

Your wine needs to be stored, protected, showcased and prepared for enjoyment. These are competing functions that your wine climate cabinet, equal to a wine cellar, achieves year after year with unflappable aplomb.

Behind its door frames of existing furniture material or stainless steel, with or without handles, lies a sanctuary free from disturbance. Up to three separate temperature zones can be set between 5 °C and 20 °C replicating a long-term cellar environment and the perfect drinking temperatures.

Meanwhile five pre-programmed light options, crafted oak bottle presenters and fully extendable trays exhibit your coveted collection with due reverence. Humidity is kept constant, sound is muffled, vibrations suppressed, aromas are filtered by activated charcoal while the treated glass doors cut UV rays. Yet all this security is powerless to stop you gently pushing the door and plundering.

Watch our viniculture film and discover more on our website.



Dishwashers

Clean with care and intelligence,
before revealing it beautifully.

200 series



Robustly effective and incredibly gentle, in the same wash.





A dishwasher for every occasion, the 200 series.

Dishwashers 200 series

The luxury of choice

The dishwashing 200 series offers you a wealth of options. Aesthetically you can choose between handles or not. Would you prefer a subtle lateral info-light to inform you that the dishwasher is on or for the remaining time of the programme to be projected onto the floor? Appreciate an extra cleaning area that directs water specifically in one section for cleaner cups and spotless glasses? Prefer the gentler drying of Zeolite? These are choices that will help you to arrive at the perfect Gaggenau dishwasher 200 series.

The choices continue

Hone your dishwasher's performance. Personalise programmes and speed up the cycle while it is running or temporarily quietening the dishwasher, useful when entertaining guests. Use the Home Connect app to suggest and even download the most suitable programmes.

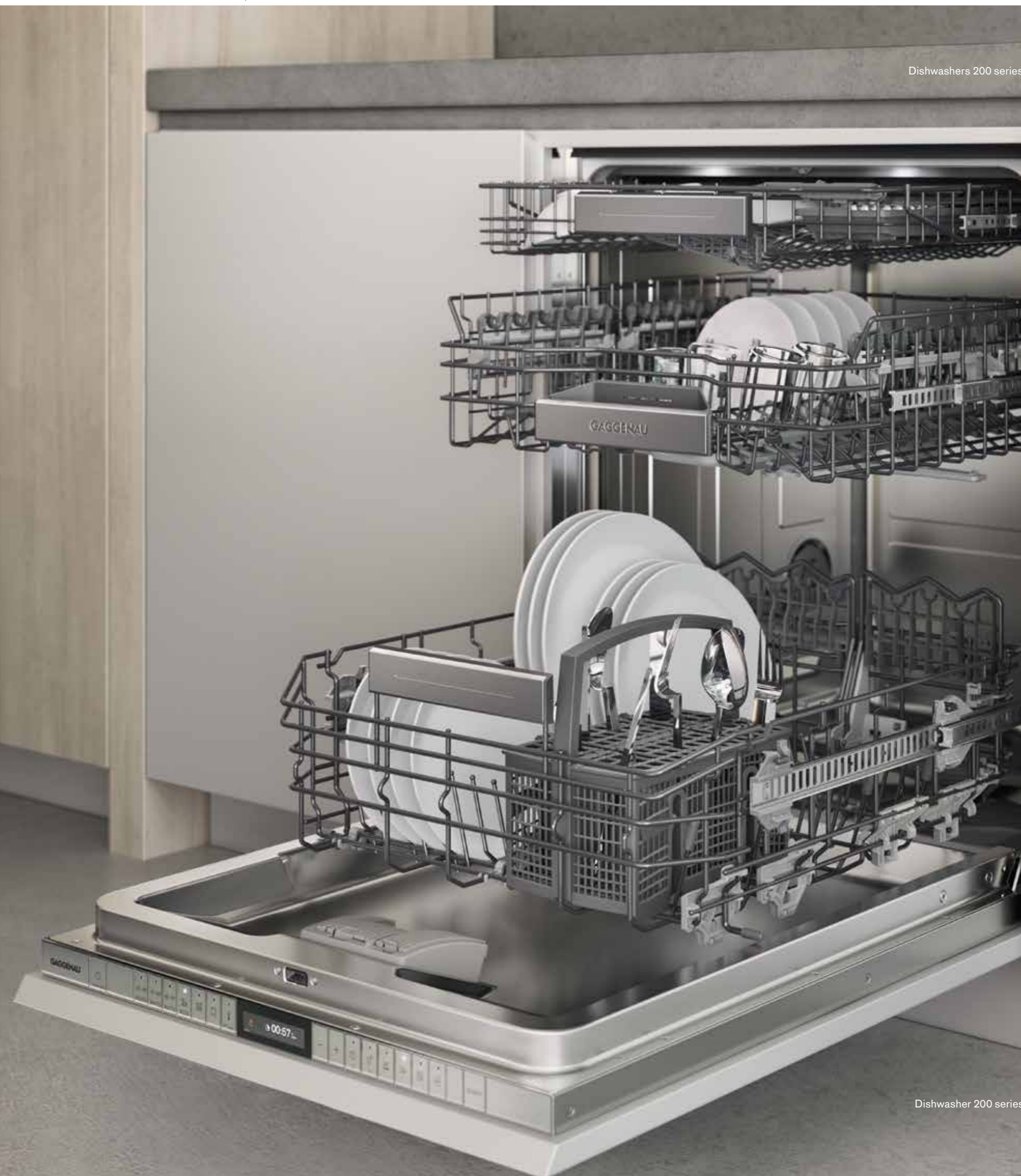

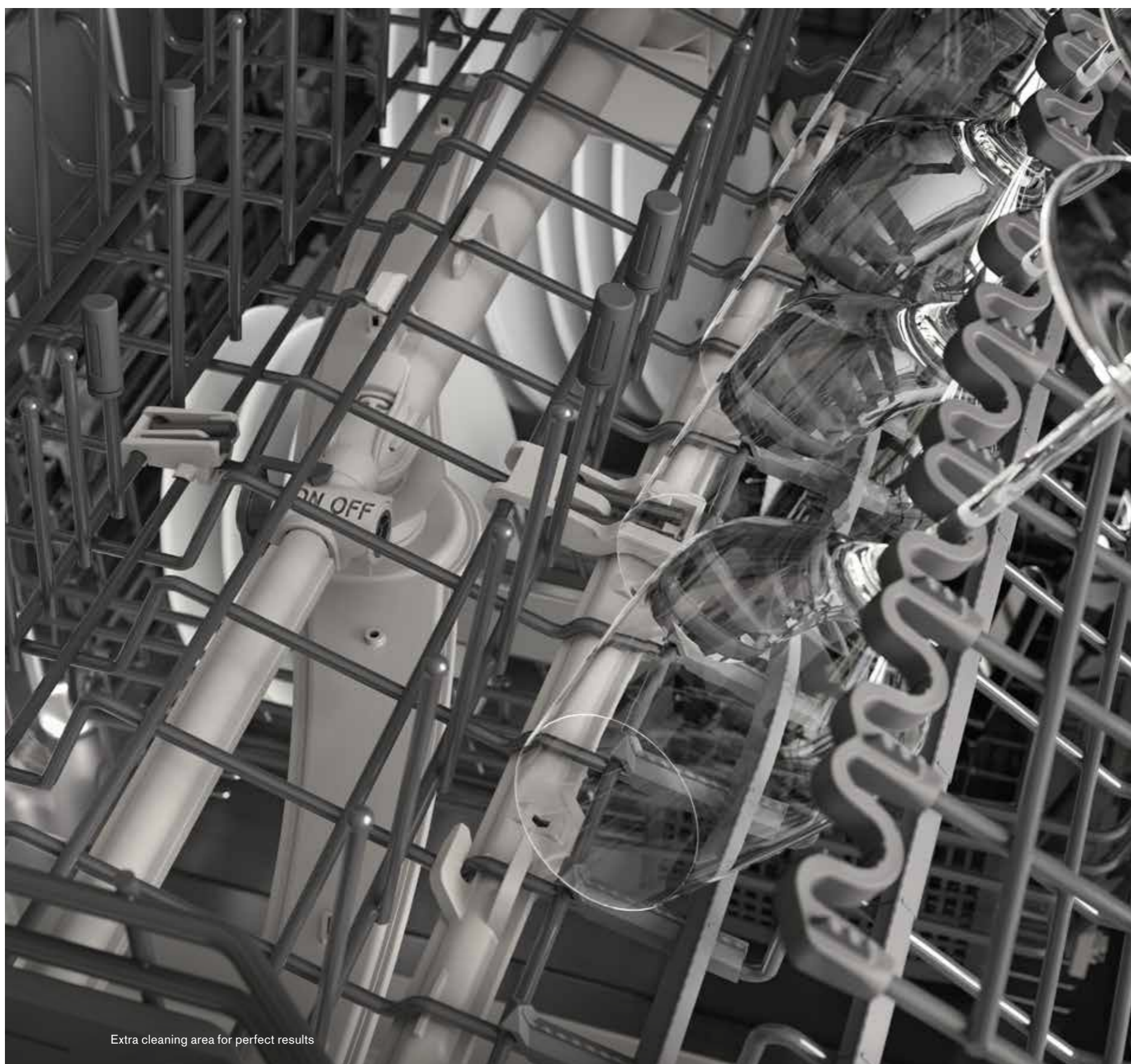

Extra cleaning area for perfect results



A third drawer at the top, to stow cups and bowls safely

Dishwashers 200 series

The Gaggenau difference

What distinguishes every Gaggenau dishwasher 200 series, is the detail. The new flexible basket system secures glasses and crystal with silicon tipped holders that fold down to alternatively offer a non-slip extra shelf. Depending upon the model, smooth running rails or wheels provide controlled, effortless movement of the drawers and baskets.

A special accessory, a top, third drawer, gives the user another level to safely stow cups and bowls. And for gentler, more efficient drying, the door can be set to automatically open at the end of the cycle. All that can be done to protect the contents, is done, superbly.

These are details that are more than considered, they are polished to perfection.

| Explore the 200 series at gaggenau.com

Appliance overview

Ovens

Cooktops

Extractors

Refrigerators

Wine climate cabinets

Dishwashers

Ovens 400 Series



Oven
BO 480 112 ₹ 8,02,700
 Right-hand hinge

Width 76 cm,
 Stainless steel-backed full glass door

Included in the price:
 1 baking tray, enamelled
 pyrolysis-safe,
 1 rotisserie spit,
 1 wire rack,
 1 grill tray with wire rack,
 1 plug-in core temperature probe
 *till stock lasts



Oven
BO 481 112 ₹ 8,02,700
 Left-hand hinge

Width 76 cm,
 Stainless steel-backed full glass door

Included in the price:
 1 baking tray, enamelled
 pyrolysis-safe,
 1 rotisserie spit,
 1 wire rack,
 1 grill tray with wire rack,
 1 plug-in core temperature probe
 *till stock lasts



Oven
BO 470 112 ₹ 7,41,750
 Right-hand hinge

Width 60 cm,
 Stainless steel-backed full glass door

Included in the price:
 2 baking trays, enamelled
 pyrolysis-safe
 1 rotisserie spit
 1 glass tray
 1 wire rack
 1 grill tray with wire rack
 1 plug-in core temperature probe
 *till stock lasts



Oven
BO 471 112 ₹ 7,41,750
 Left-hand hinge

Width 60 cm,
 Stainless steel-backed full glass door

Included in the price:
 2 baking trays, enamelled
 pyrolysis-safe
 1 rotisserie spit
 1 glass tray
 1 wire rack
 1 grill tray with wire rack
 1 plug-in core temperature probe
 *till stock lasts



Combi-Steam Ovens
BS 470 112 ₹ 7,87,750
 Right-hand hinge

Width 60 cm,
 Stainless steel-backed full glass door
 Fixed inlet and outlet water connection

Included in the price:
 1 Cooking container, stainless steel, perforated
 1 Cooking container, stainless steel, unperforated
 1 wire rack
 1 plug-in core temperature probe
 1 outlet hose (3 m long)
 1 water inlet hose (3 m long)
 4 cleaning cartridge
 *till stock lasts



Combi-Steam Ovens
BS 471 112 ₹ 7,87,750
 Left-hand hinge

Width 60 cm,
 Stainless steel-backed full glass door
 Fixed inlet and outlet water connection

Included in the price:
 1 Cooking container, stainless steel, perforated
 1 Cooking container, stainless steel, unperforated
 1 wire rack
 1 plug-in core temperature probe
 1 outlet hose (3 m long)
 1 water inlet hose (3 m long)
 4 cleaning cartridge
 *till stock lasts



Combi-Steam Ovens
BS 474 112 ₹ 7,87,750
 Right-hand hinge

Width 60 cm,
 Stainless steel-backed full glass door
 Fixed inlet and outlet water connection

Included in the price:
 1 Cooking container, stainless steel, perforated
 1 Cooking container, stainless steel, unperforated
 1 wire rack
 1 plug-in core temperature probe
 1 outlet hose (3 m long)
 1 water inlet hose (3 m long)
 4 cleaning cartridge
 *till stock lasts



Combi-Steam Oven
BS 475 112 ₹ 7,87,750
 Left-hand hinge

Width 60 cm,
 Stainless steel-backed full glass door
 Fixed inlet and outlet water connection

Included in the price:
 1 Cooking container, stainless steel, perforated
 1 Cooking container, stainless steel, unperforated
 1 wire rack
 1 plug-in core temperature probe
 1 outlet hose (3 m long)
 1 water inlet hose (3 m long)
 4 cleaning cartridge
 *till stock lasts



Combi-Steam Oven
BS 454 111 ₹ 7,70,500
 Right-hand hinge

Width 60 cm,
 Stainless steel-backed full glass door
 Water tank for fresh and waste water

Included in the price:
 1 Cooking container, stainless steel, perforated
 1 Cooking container, stainless steel, unperforated
 1 wire rack
 1 plug-in core temperature probe
 4 cleaning cartridge
 *till stock lasts

Overview Ovens 400 Series



Combi-Steam Oven
BS 455 111 ₹ 7,70,500
 Left-hand hinge

Width 60 cm,
 Stainless steel-backed full glass door
 Water tank for fresh and waste water

Included in the price:
 1 Cooking container, stainless steel, perforated
 1 Cooking container, stainless steel, unperforated
 1 wire rack
 1 plug-in core temperature probe
 4 cleaning cartridge
 *till stock lasts



Combi-Steam Oven
BS 450 111 ₹ 7,70,500
 Right-hand hinge

Width 60 cm,
 Stainless steel-backed full glass door
 Water tank for fresh and waste water

Included in the price:
 1 Cooking container, stainless steel, perforated
 1 Cooking container, stainless steel, unperforated
 1 wire rack
 1 plug-in core temperature probe
 4 cleaning cartridge
 *till stock lasts



Combi-Steam Oven
BS 451 111 ₹ 7,70,500
 Left-hand hinge

Width 60 cm,
 Stainless steel-backed full glass door
 Water tank for fresh and waste water

Included in the price:
 1 Cooking container, stainless steel, perforated
 1 Cooking container, stainless steel, unperforated
 1 wire rack
 1 plug-in core temperature probe
 4 cleaning cartridge
 *till stock lasts



Combi-Microwave Oven
BM 454 110 IN ₹ 7,41,750
 Right-hand hinge

Width 60 cm,
 Stainless steel-backed full glass door

Included in the price:
 1 combination wire rack
 1 glass tub
 *till stock lasts



Combi-Microwave Oven
BM 455 110 IN ₹ 7,41,750
 Left-hand hinge

Width 60 cm,
 Stainless steel-backed full glass door

Included in the price:
 1 combination wire rack
 1 glass tub
 *till stock lasts



Coffee Machine
CM 450 112 ₹ 7,41,750
 Left-hand hinge

Width 60 cm,
 Stainless steel behind glass,
 Removable water tank

Included in the price:
 1 assembly screws
 1 scoop
 1 test strip
 1 milk container (insulated)
 1 connection hose for milk frother
 1 milk tube
 *till stock lasts



Vacuuming Drawer
DV 461 110 ₹ 5,63,500
 Right-hand hinge

Width-60cm and Height- 14 cm
 Stainless steel behind glass

Included in the price:
 50 Vacuuming bags, small
 50 Vacuuming bags, big
 1 Raised vacuuming platform
 1 Adaptor f. vacuuming outside the chamber
 1 Vacuuming hose
 1 Adaptor for bottle plugs
 3 Plugs for vacuuming of bottles
 *till stock lasts



Warming Drawer
WS 462 112 ₹ 2,93,250
 Right-hand hinge

Width-60cm and Height- 29 cm
 Stainless steel behind glass
 *till stock lasts

Included in the price:
 *till stock lasts



Warming Drawer
WS 461 112 ₹ 2,47,250
 Right-hand hinge

Width-60cm and Height- 14 cm
 Stainless steel behind glass
 *till stock lasts

Included in the price:
 *till stock lasts

Overview Ovens 400 Series

Ovens

Appliance type	BO 470/BO 471 BO 480/BO 481
Heating methods	17
Hot air	•
Eco hot air	•
Top heat + bottom heat	•
Top heat	•
Bottom heat	•
Hot air + bottom heat	•
Top + 1/3 bottom heat	•
1/3 top + bottom heat	•
Hot air + 1/3 bottom heat	•
Full surface grill + circulated air	•
Full surface grill	•
Compact grill	•
Baking stone function	•
Roaster function	•
Dough proofing	•
Defrosting	•
Keeping warm	•

Appliance type	BO 480/BO 481 BO 470/BO 471
Control options	
Temperature selection from 30 °C to 300 °C depending on heating methods	•
Home Connect functions Automatic programmes, remote control and monitoring, recipes	•
Door opening via voice assistant possible	•

*only Home Connect basics functions, no auto. prog.

Culinary warming drawers

Appliance type	WS 461 WS 462
Heating methods	
Temperature selection from 30 to 80 °C (Defrosting, dough proofing, herbs/fruits drying, melting/maturing, preheating small beverage containers, slow/low temperature cooking*, keeping warm, warming ovenware/cups/plates)	•
4 standard heating modes (Cups, plates, keep warm, slow cooking)	•
Personalisation function via Home Connect (favourite programme, 16 additional programmes, timing function, recipes)	•

*improved temperature stability for WS 461/462.

Combi-Steam Ovens

Appliance type	BS 470 BS 474 BS 450 BS 454/BS 455
Heating methods	13
Hot air + 100% humidity	•
Hot air + 80% humidity	•
Hot air + 60% humidity	•
Hot air + 30% humidity	•
Hot air + 0% humidity	•
Low temperature cooking	•
Sous-vide cooking	•
Full surface grill level 1 + humidity	•
Full surface grill level 2 + humidity	•
Full surface grill + circulated air	•
Dough proofing	•
Defrosting	•
Regenerating	•

Control options	
Temperature selection from 30 °C to 230 °C combined with chosen humidity level	•
Home Connect functions Automatic programmes, remote control and monitoring, recipes	•
Door opening via voice assistant possible	•

Ovens 200 Series



Oven
BOP 250 102 ₹ 6,15,250
A Right-hand hinge
Width 60cm
Anthracite

Included in the price:
1 baking tray, enamelled pyrolysis-safe
1 glass tray
1 wire rack
1 plug-in core temperature probe
*till stock lasts



Oven
BOP 251 102 ₹ 6,15,250
A Left-hand hinge
Width 60cm
Anthracite

Included in the price:
1 baking tray, enamelled pyrolysis-safe
1 glass tray
1 wire rack
1 plug-in core temperature probe
*till stock lasts



Combi-Steam Ovens
BSP 270 101 ₹ 7,30,250
A Right-hand hinge
Width 60cm
Anthracite
Fixed inlet and outlet water connection

Included in the price:
1 Cooking container, stainless steel, perforated
1 Cooking container, stainless steel, unperforated
1 wire rack
1 plug-in core temperature probe
1 outlet hose (3 m long)
1 water inlet hose (3 m long)
4 cleaning cartridge
*till stock lasts



Combi-Steam Ovens
BSP 250 101 ₹ 6,72,750
A Right-hand hinge
Width 60cm
Anthracite
Water tank for fresh and waste water

Included in the price:
2 baking trays, enamelled pyrolysis-safe
1 rotisserie spit
1 glass tray
1 wire rack
1 grill tray with wire rack
1 plug-in core temperature probe
*till stock lasts



Combi-Steam Ovens
BSP 251 101 ₹ 6,72,750
A Left-hand hinge
Width 60cm
Anthracite
Water tank for fresh and waste water

Included in the price:
1 Cooking container, stainless steel, perforated
1 Cooking container, Stainless steel, unperforated
1 wire rack
1 plug-in core temperature probe
*till stock lasts



Combi-Microwave Oven
BMP 250 100I ₹ 6,32,500
A Right-Door hinge
Width 60cm
Anthracite

Included in the price:
1 combination wire rack
1 glass tub
*till stock lasts



Combi-Microwave Oven
BMP 251 100I ₹ 6,32,500
A Left-hand hinge
Width 60cm
Anthracite

Included in the price:
1 combination wire rack
1 glass tub
*till stock lasts



Microwave
BMP 224 100 ₹ 3,04,750
A Right-hand hinge
Width 60cm
Anthracite

Included in the price:
1 glass tray
1 wire rack
*till stock lasts



Microwave
BMP 225 100 ₹ 3,04,750
A Left-hand hinge
Width 60cm
Anthracite

Included in the price:
1 glass tray
1 wire rack
*till stock lasts

Overview Ovens 200 Series



Warming Drawer
WSP 222 102

Width 60cm and Height 29 cm
Anthracite
*till stock lasts

₹ 2,41,489



Warming Drawer
WSP 221 102

Width 60cm and Height 14 cm
Anthracite
*till stock lasts

₹ 2,18,500



Coffee Machine
CMP 250 102

Width 60cm
Anthracite
Removable water tank

₹ 5,06,000

Included in the price:

- 1 assembly screws
- 1 scoop
- 1 test strip
- 1 milk container (insulated)
- 1 connection hose for milk frother
- 1 milk tube
- *till stock lasts

Overview Ovens 200 Series

Ovens

Appliance type	BOP 250/251
Heating methods	13
Hot air	•
Eco hot air	•
Top + bottom heat	•
Top heat	•
Bottom heat	•
Hot air + bottom heat	•
Top + 1/3 bottom heat	•
1/3 top + bottom heat	•
Hot air + 1/3 bottom heat	•
Full surface grill + circulated air	•
Full surface grill	•
Compact grill	•
Baking stone function	•
Roaster function	•
Dough proofing	•
Defrosting	•
Keeping warm	•

Control options	
Temperature selection from 30 °C to 300 °C depending on heating methods	•
Temperature selection from 50 °C to 300 °C depending on heating methods	•
Home Connect functions Automatic programmes, remote control and monitoring, recipes	•

*only Home Connect basics functions, no auto. prog.

Culinary warming drawers

Appliance type	WSP 221 WSP 222
Heating methods	
Temperature selection from 30 to 80 °C (Defrosting, dough proofing, herbs/fruits drying, melting/maturing, preheating small beverage containers, slow/low temperature cooking*, keeping warm, warming ovenware/cups/plates)	•
4 standard heating modes (Cups, plates, keep warm, slow cooking)	•
Personalisation function via Home Connect (favourite programme, 16 additional programmes, timing function, recipes)	•

*improved temperature stability for WS 461/462.

Combi-Steam Ovens

Appliance type	BSP 270 BSP 250/251
Heating methods	13
Hot air + 100% humidity	•
Hot air + 80% humidity	•
Hot air + 60% humidity	•
Hot air + 30% humidity	•
Hot air + 0% humidity	•
100% humidity	•
Low temperature cooking	•
Low temperature steaming	•
Sous-vide cooking	•
Full surface grill level 1 + humidity	•
Full surface grill level 2 + humidity	•
Full surface grill + circulated air	•
Dough proofing	•
Defrosting	•
Regenerating	•

Control options	
Temperature selection from 30 °C to 230 °C combined with chosen humidity level	•
Temperature selection from 30 °C to 100 °C depending on heating methods	•
Automatic programmes, remote control and monitoring, recipes	•

*only Home Connect basics functions, no auto. prog.

Key

- Also available with control at the top or bottom
- Home Connect
- * Energy efficiency class: at a range of energy efficiency classes from A+++ to D.
- ** Suitable for 400 and 200 series.

All 200 series appliances are available with left or right hinged doors, except for the espresso machine, warming drawer and vacuuming drawer.

The Oven Eb 333



Oven

EB 333 111 ₹ 12,07,500



Width 90cm and Height 48 cm
Stainless steel
Drop Down Door Control on right

Included in the price:

- 1 baking tray, enamelled pyrolysis-safe
- 1 rotisserie spit
- 1 wire rack
- 1 grill tray with wire rack
- 1 plug-in core temperature probe

Overview Oven Eb 333

Heating methods	
Heating methods	17
Hot air	•
Eco hot air	•
Top + bottom heat	•
Top heat	•
Bottom heat	•
Hot air + bottom heat	•
Top + 1/3 bottom heat	•
1/3 top + bottom heat	•
Hot air + 1/3 bottom heat	•
Full surface grill + circulated air	•
Full surface grill	•
Compact grill	•
Baking stone function	•
Roaster function	•
Dough proofing	•
Defrosting	•
Keeping warm	•
Control options	
Temperature selection from 30 °C to 300 °C depending on heating methods	•
Home Connect functions Automatic programmes, remote control and monitoring, recipes	•

Home Connect

Baking Accessories

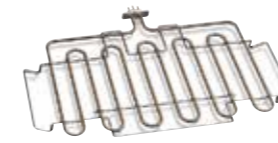

BA 058 115 ₹ 8,600

Heating element for baking stone and Gastronorm roaster.

- BO 480 112 / BO 481 112 / EB 333110

*till stock lasts



BA 058 133 ₹ 36,800

Baking stone
Incl.baking stone support and pizza paddle (heating element must be ordered separately).

- Not in combination with pull-out system.
- Fits to BO 480 112 / BO 481 112 / EB 333 110

*till stock lasts



BA 056 115 ₹ 10,950

Heating element for baking stone and Gastronorm roaster.

- Fits with all the 60 cm BO single oven

*till stock lasts



BA 056 133 ₹ 36,000

Baking stone
Incl.baking stone support and pizza paddle (heating element must be ordered separately).

- Fits with all the 60 cm BO single oven
- Not in combination with pull-out system.

*till stock lasts



BA 080 670 ₹ 7,000

Vacuuming bags, small, 180 mm x 280 mm, 200 pcs.

- Not in combination with pull-out system.

*till stock lasts



BA 080 680 ₹ 10,000

Vacuuming bags, large, 240 mm x 350 mm, 200 pcs.

- Fits to DV461100, DV461110, DVP221100, DVP221110, DVP221130

*till stock lasts

Vario Cooktops 400 Series



Full Surface Induction
CX 482 111 ₹ 11,15,500
A
 Full surface induction cooktop 80 cm
Included in the price:
 1 Cooking sensor for temperature regulation



CKI420010
Set of 2 knobs

Vario Flex Induction Cooktop
VI 422 115 ₹ 4,54,250
A Knobs to be ordered separately.
 Vario flex induction cooktop 38 cm
Included in the price:
 (CKI 420 010) Knob included in price to be ordered with appliances



Vario Gas Cooktop
VG 491 111IN ₹ 7,30,250
A
 Vario gas cooktop 90 cm Liquidgas
Included in the price:
 1 Wok attachment ring



Vario Gas Cooktop
VG 425 111IN ₹ 5,69,250
A
 Vario gas cooktop 38 cm Liquidgas



Vario Gas Work
VG 415 111IN ₹ 4,94,500
A
 Vario gas cooktop 38 cm Liquidgas
Included in the price:
 1 Wok attachment ring



CKP420010
Set of 2 knobs

Vario Teppan Yaki
VP 414 115 ₹ 5,17,500
A Knobs to be ordered separately.
 Vario Teppan Yaki 38 cm
Included in the price:
 (CKP 420 010) Knob included in price to be ordered with appliances, 2 spatula



CKR420010
Set of 2 knobs

Vario Electric Grill
VR 414 115 ₹ 4,08,250
A Knobs to be ordered separately.
 Vario electric grill 38 cm
Included in the price:
 1. cast pan, half size
 2. cast grills
 3. lava stone
 4. cleaning brush

Cooktops 200 series



Vario Flex Induction Cooktop
VI 262 120IN ₹ 3,73,750
A
 Vario induction hob 60 cm
Included in the price:
 1 Glass scraper



Vario Flex Induction Cooktop
VI 232 120IN ₹ 2,81,750
A
 Vario flex induction cooktop 28 cm
Included in the price:
 1 Glass scraper



Vario Gas Cooktop
VG 295 150IN ₹ 4,19,750
A
 Gas cooktop 90 cm Liquidgas
Included in the price:
 1 Wok attachment ring



Vario Gas Cooktop
VG 264 120IN ₹ 3,27,750
A
 Vario gas cooktop 60 cm Liquidgas



Vario Gas Cooktops
VG 232 120IN ₹ 2,24,250
A
 Vario gas cooktop 28 cm Liquidgas



Vario Gas Cooktops
VG 231 120IN ₹ 2,18,500
A
 Vario gas cooktop 28 cm Liquidgas
Included in the price:
 1 Wok attachment ring



Vario Teppan Yaki
VP 230 120 ₹ 3,27,750
A
 Vario Teppan Yaki 28 cm
Included in the price:
 2 spatula



Vario Electric Grill
VR 230 120 ₹ 2,53,000
A
 Vario electric grill 28 cm
Included in the price:
 1 grease collecting insert
 1 cast grill
 1 lava stone
 1 cleaning brush

Cooking Accessories



VA 420 010 w.o.lid ₹ 10,950

Connection strip for combination with other Vario appliances of the 400 series for surface mounting



VA 420 004 ₹ 22,500

Connection strip for combination with other Vario appliances of the 400 series for flush mounting



VV 200 010 ₹ 24,700

Stainless steel connection strip for combination with other Vario appliances of the 200 series



VV 200 020 ₹ 32,350

Black connection strip for combination with other Vario appliances of the 200 series



AA 414 010 ₹ 7,000

Ventilation moulding for VL 414 next to gas appliance



LS 041 001 ₹ 7,000

Ventilation moulding for VL 200 next to gas appliance Stainless steel



CA 052 300 ₹ 28,250

Griddle plate in cast aluminium
– Non-stick
– For flex induction cooktops



CA 051 301 ₹ 40,500

Teppan Yaki plate made of multi ply material
– For flex induction cooktops

Extractors 400 Series



Vario Ceiling Ventilation
AC 402 181 ₹ 2,87,500

A
Ceiling cooker hood 80 cm
Motor and control unit to be ordered additionally with the appliance



Ceiling Ventilation
AC 482 181 ₹ 2,30,000

A
Accessory Ceiling Ventilation



Ceiling Ventilation
AC 472 181 ₹ 1,98,000

A
Accessory Ceiling Ventilation



Table Ventilation
AL 400 122 ₹ 7,13,000

A
Table ventilation 120 cm
Stainless steel



Wall Mounted Hood
AW 442 120 ₹ 5,69,250

A
Wall-mounted cooker hood 120 cm
Stainless steel
Need to order installation tower and motor as additional accessories



Vario Downdraft Ventilation
VL 414 115 ₹ 3,62,250

A
Vario downdraft ventilation 15 cm
Stainless steel
Knob included in price to be ordered with appliances

* Please note that special Vario 400 knobs must be used for each cooktop.
Single knobs can only be ordered for specific appliances.

**Also available separately.

Extractors 200 Series



Ceiling Ventilation

AC 250 121

₹ 4,54,250

Ceiling cooker hood 120 cm
Gaggenau Light Bronze

Wall Mounted Hood

AW 240 191

₹ 2,87,500

Wall-mounted hood 90 cm
Stainless steelDelivery with mounting kit and
chimney

Flat Kitchen Hood

AF 210 192

₹ 2,24,250

Telescopic cooker hood 90 cm
Stainless steelOrder lowering frame as a additional
accessories

Flat Kitchen Hood

AF 210 162

₹ 1,84,000

Flat kitchen hood 60 cm
Stainless steelOrder lowering frame as a additional
accessories

Vario Downdraft Ventilation

VL 200 120

₹ 2,81,750

Vario downdraft ventilation 15 cm
Black

Ventilation Accessories



AR 400 142

₹ 83,000

- Powerful remote fan unit to combine with motorless appliances 400 series
- Air extraction
- Max. air output 830 m³/h
- Efficient BLDC technology
- Inside installation
- Metal housing
- 3 electronically controlled power levels and one intensive mode.
- Pipe connection pieces on intake side: 1 x NW 200 round, 4 x NW 150 round.
- Installation in a separate room allows for a reduced noise level in the kitchen



AR 400 143

₹ 64,000

- Powerful remote fan unit to combine with motorless appliances 400 series
- Installation in the chimney of AI/ AW 442
- Max. air output 970 m³/h
- Air extraction/Air recirculation
- Efficient BLDC technology
- Metal housing
- 3 electronically controlled power levels and one intensive mode.
- Including sound insulation to minimise the noise level.
- Pipe connection pieces on output side: 1x NW 150 round.
- Energy efficiency class A+.



AR 401 142

₹ 1,12,500

- Powerful remote fan unit to combine with motorless appliances 400 series
- Max. air output 910 m³/h
- Air extraction
- Efficient BLDC technology
- Outside wall mounting
- Stainless steel
- 3 electronically controlled power levels and one intensive mode.
- Including sound insulation to minimise the noise level.
- Pipe connection pieces on intake side: 1x NW 200 round.
- Retaining bracket for installation on an outside wall enclosed.



AR 410 110

₹ 98,000

- Powerful remote fan unit to combine with motorless appliances 400 series
- Efficient BLDC technology
- Particularly quiet due to patented noise insulation
- 3 electronically controlled power levels and one intensive mode.
- Pipe connection pieces on intake side: 1 x NW 150 flat duct
- Including sound insulation to minimise the noise level.
- Max. air output 675 m³/h.



AR 403 122

₹ 85,000

- Powerful remote fan unit to combine with motorless appliances 400 series
- Air extraction
- Max. air output 730 m³/h
- Compact and space-saving installation in a 10 cm high plinth
- 3 electronically controlled power levels and one intensive mode.
- Metal housing, zinc-plated.
- Pipe connection pieces on output side: 1x NW 150 flat duct.
- Retaining bracket for installation on the ceiling or side.



AR 413 122

₹ 94,000

- Information:
First charcoal filter is included.
- Powerful remote fan unit to combine with motorless appliances 400 series
 - Air recirculation
 - Max. air output 760 m³/h
 - Efficient BLDC technology
 - Compact and space-saving installation in a 10 cm high plinth
 - Metal housing
 - 3 electronically controlled power levels and one intensive mode.
 - Metal housing, zinc-plated.
 - Retaining bracket for installation on the ceiling or side of a cupboard enclosed.
 - 2 activated charcoal filters enclosed ex factory.



AA 211 812

₹ 31,500

Patented air recirculation module including 1 activated charcoal filter with high efficient odour reduction due to increased surface

- For air recirculation.
- Can be combined with flat kitchen hood series 200 / canopy extractor series 200.
- For assembly in the upper cabinet.
- Odour reduction comparable to air extraction mode (95%)
- Noise reduction of up to 3 dB when compared to conventional air recirculation filter systems. Fits to AC200160, C200180, AC200190,



AA 210 492

₹ 28,000

Lowering frame for 90cm
Flat kitchen hoods

- Fits to AF 210 192



AA 210 460

₹ 22,500

Lowering frame for 60cm
Flat kitchen hoods

- Fits to AF 210 192

Overview

Ceiling ventilation 400 series



AC 402 181
AC 482 181
AC 472 181



AR 400 142 AR 401 142 AR 403 122

Table ventilation 400 series



AL 400 192
AL 400 122



AR 400 142 AR 401 142 AR 403 122 AR 413 122 AR 410 110 only with AL 400 122

Downdraft ventilation 400 and 200 series



VL 414 115 VL 200 120



CKV 410 010
CKV 410 000

Wall-mounted hood 400 series



AW 442 120



AR 400 142 AR 401 142



AR 400 143

200 series

Refrigerator 400 Series



Vario Refrigerator
RC 492 304 ₹ 18,68,750



Vario built-in fridge 212.5 x 90.8 cm
soft close flat hinge

Included in the price:
1 egg holder with lid
*till stock lasts



Vario Refrigerator
RC 472 304 ₹ 16,50,250



Vario built-in fridge 212.5 x 75.6 cm
soft close flat hinge

Included in the price:
1 egg holder with lid
*till stock lasts



Vario Refrigerator
RC 462 304 ₹ 12,47,750



Vario refrigerator 212.5 x 60.3 cm
soft close flat hinge

Included in the price:
1 egg holder with lid
*till stock lasts



Vario Fridge-Freezer Combination
RB 492 305 ₹ 17,53,750



Vario fridge-freezer combination 212.5 x
90.8 cm soft close flat hinge

Included in the price:
1 egg holder with lid
1 ice cube scoop
*till stock lasts



Vario Fridge-Freezer Combination
RB 472 305 ₹ 16,38,750



Vario fridge-freezer combination
212.5 x 75.6 cm soft close flat hinge

Included in the price:
1 egg holder with lid
1 ice cube scoop
*till stock lasts



Vario Freezer
RF 461 304 ₹ 14,14,500



Vario freezer 212.5 x 60.3 cm
soft close flat hinge

Included in the price:
1 egg holder with lid
1 ice cube scoop
*till stock lasts



Vario Freezer
RF 463 305 ₹ 14,14,500



Vario freezer 212.5 x 60.3 cm
soft close flat hinge

Included in the price:
1 egg holder with lid
1 ice cube scoop
*till stock lasts



Vario Freezer
RF 471 304 ₹ 13,77,700



Vario built-in freezer 212.5 x 75.6 cm
soft close flat hinge

Included in the price:
1 egg holder with lid
1 ice cube scoop
1 accessory for side by side
*till stock lasts



Vario Freezer
RF 411 304 ₹ 11,78,750



Vario built-in freezer 212.5 x 45.1 cm
soft close flat hinge

Included in the price:
1 egg holder with lid
1 ice cube scoop
1 accessory for side by side installation
*till stock lasts

Wine Cabinet 400 Series



Vario Wine Climate Cabinet

RW 466 364 ₹ 12,93,750



Vario Wine Climate Cabinet
212.5 x 60.3 cm

Included in the price:
Accessory for side by side
installation
*till stock lasts



Vario Wine Climate Cabinet

RW 414 364 ₹ 12,36,250



Vario Wine Climate Cabinet
212.5 x 45.1 cm

Included in the price:
Accessory for side by side
installation
*till stock lasts

Cooling Accessories



RA 421 712 with handle ₹ 67,200

RA 428 712 without handle ₹ 57,000

Stainless steel door
– For RB 472, panel thickness 19 mm.
*till stock lasts



RA 421 610 with handle ₹ 50,200

RA 428 610 without handle ₹ 40,000

Stainless steel door
– For 61 cm wide appliances, panel
thickness 19 mm.
– Fits to RC 462 304, RF 461 304,
RW 464 364
*till stock lasts



RA 421 710 with handle ₹ 55,500

RA 428 710 without handle ₹ 51,000

Stainless steel door
– For 76.2 cm wide appliances, panel
thickness 19 mm.
– Fits to RC 472 304, RF 471 304
*till stock lasts



RA 422 610 with handle ₹ 49,700

RA 428 810 without handle ₹ 41,000

Stainless steel door
– For 61 cm wide appliances,
panel thickness 19 mm.
– Fits to RF 463 300, RF 463 301
*till stock lasts



RA 421 611¹ with handle ₹ 52,500

RA 421 612² with handle ₹ 58,600

RA 428 611 without handle ₹ 48,000

¹Left-hand hinge ²Right-hand hinge
Stainless steel door
– For 61 cm wide appliances, right
hinged, panel thickness 19 mm.
– Fits to RW 464 364
*till stock lasts



RA 421 910 with handle ₹ 76,500

RA 428 910 without handle ₹ 61,000

Stainless steel door
– For RB 491/492,
panel thickness 19 mm.
*till stock lasts



RA 421 110 with handle ₹ 48,500

RA 428 110 without handle ₹ 34,000

Stainless steel door
– For 45.7 cm wide appliances, panel
thickness 19 mm.
– Fits to RF411304, RW414304
*till stock lasts



RA 421 111¹ with handle ₹ 54,400

RA 421 112² with handle ₹ 49,300

RA 428 111 without handle ₹ 42,000

¹Left-hand hinge ²Right-hand hinge
Stainless steel door
– For 45.7 cm wide appliances,
left-hinged, panel thickness 19 mm.
– Fits to RW 414 364
*till stock lasts



RA 460 013 ₹ 80,000

Additional side heating element 230 V.
Required if appliances are installed with
a distance greater than 16 mm and less
than 160 mm next to each other and
for all built-in situations in a very humid
environment. Not required if appliances
are installed more than 160 mm apart
from each other.
*till stock lasts

Dishwashers 200 series



Dishwasher
DF 270 101F ₹ 2,39,700

A
 Dishwasher 60 cm Variable hinge for special installation situations

Included in the price:
 1 baking tray spray head
 1 stainless steel trim kit installation

Dishwashing Accessories



DA 041 160 ₹ 18,500

Cutlery drawer with smooth running rails
 - 3rd level above the upper basket.
 - For large pieces of cutlery, cooking utensils and espresso cups.
 - 13 place setting capacity with all 3 levels.

Ovens 400 series

Technical Drawings

BO 480 112 / BO 481 112

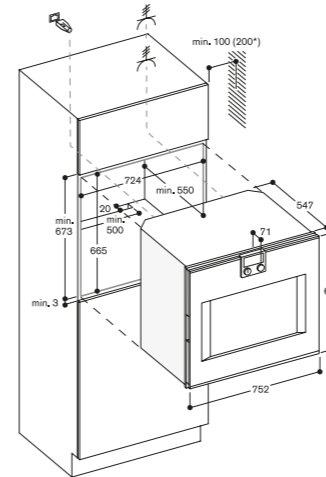

BO 470 112 / BO 471 112

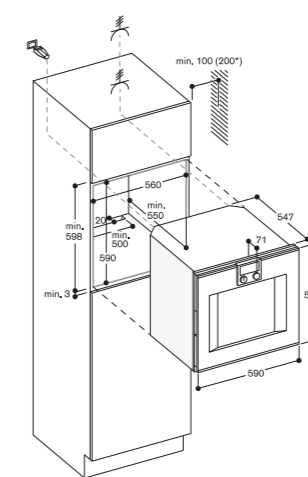

BS 470 112 / BS 471 112

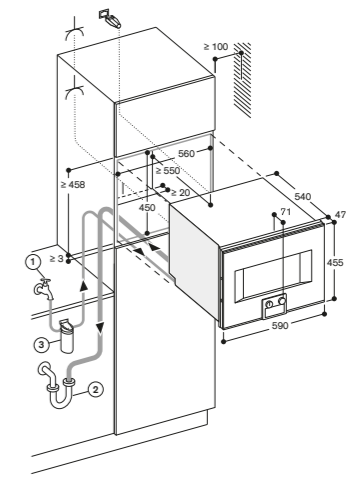

BS 474 112 / BS 475 112

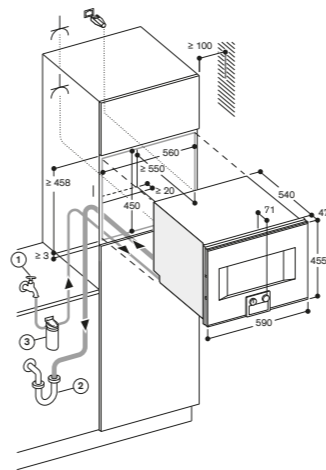

BS 454 111 / BS 455 111

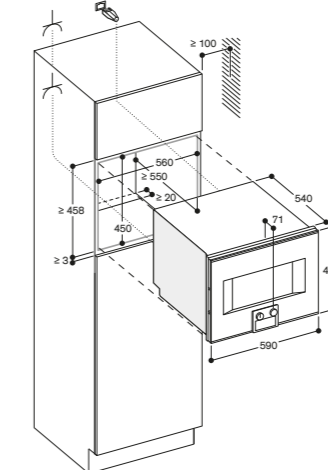

BS 450 111 / BS 451 111

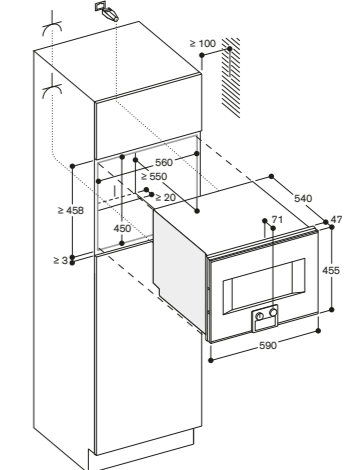

BM 454 110 / BM 455 110 IN

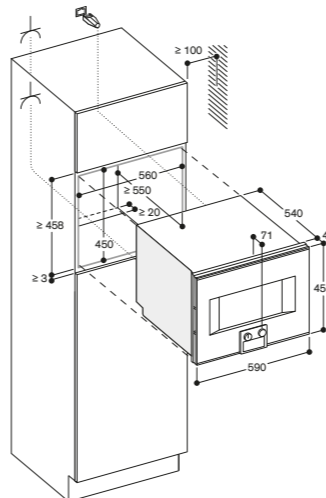

CM 450 112

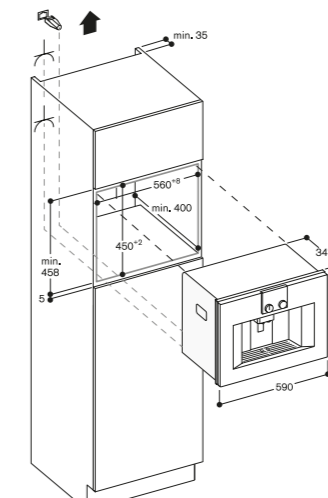

DV 461 110

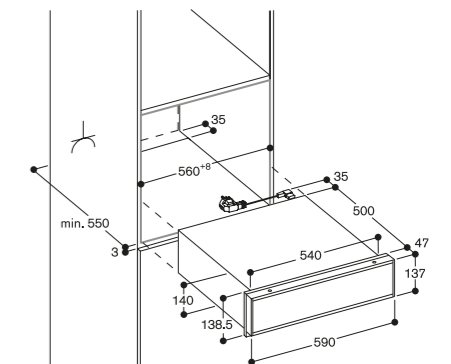

Ovens 400 series

Technical Drawings

WS 462 112

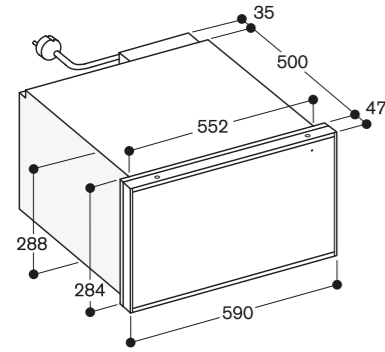

WS 461 112

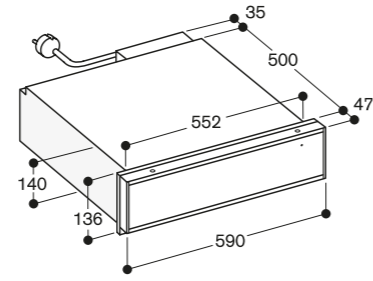

Ovens 200 series

Technical Drawings

BOP 250 102 / BOP 251 102

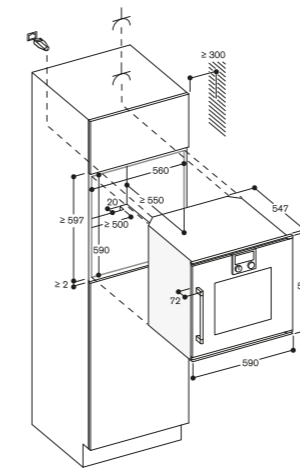

BSP 270 101

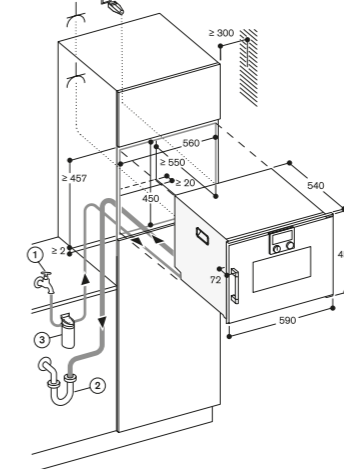

BSP 250 101 / BSP 251 101

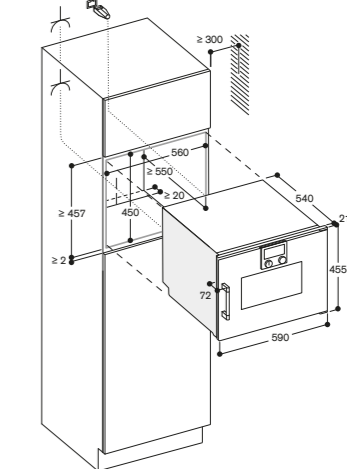

BMP 250 100I / BMP 251 100I

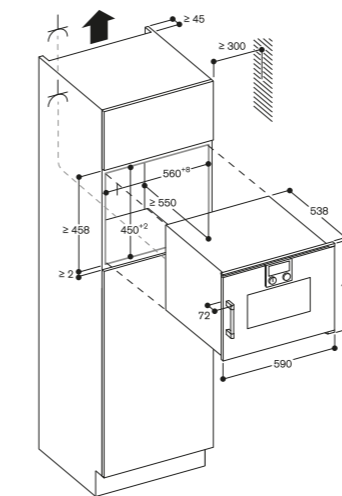

BMP 224 100 / BMP 225 100

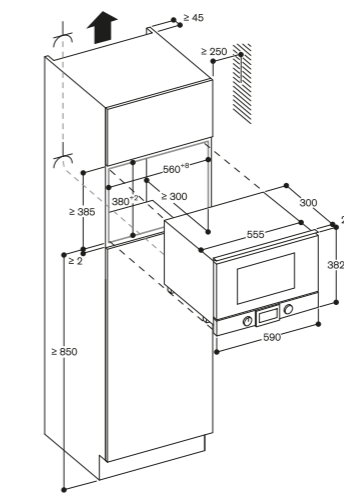

WSP 222 102

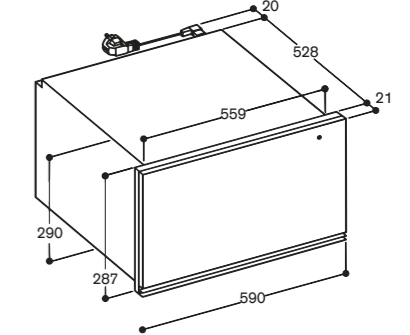

WSP 221 102

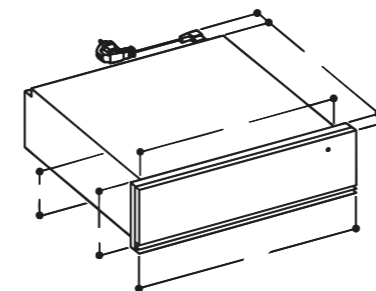

CMP 250 102

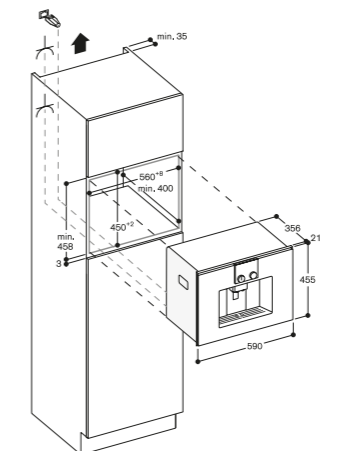

EB 333 111

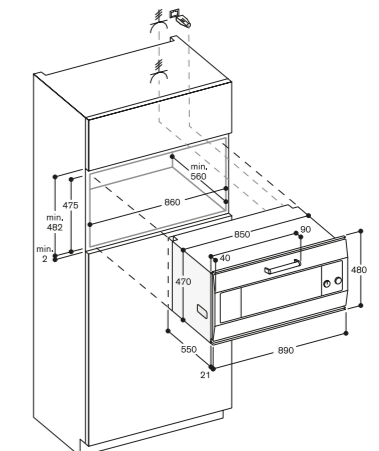

CX 482 111

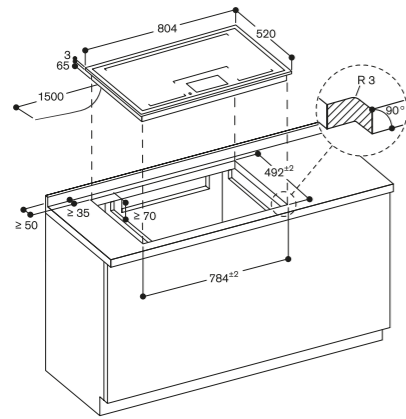

VI 422 115

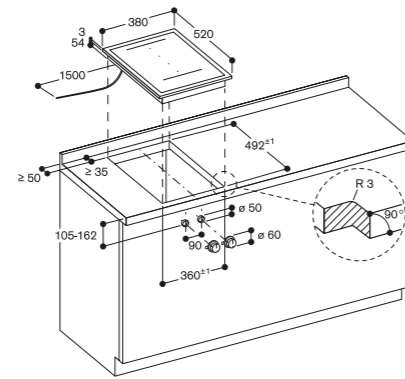

VG 491 111IN

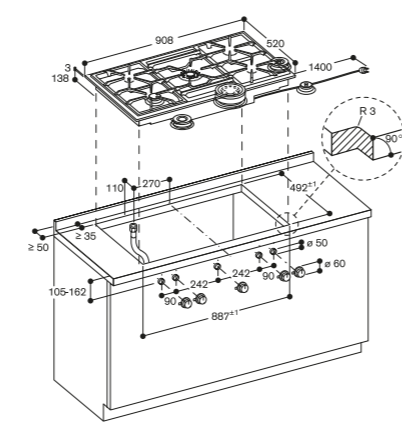

VI 262 120IN

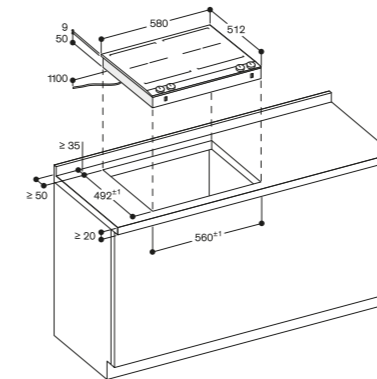

VI 232 120IN

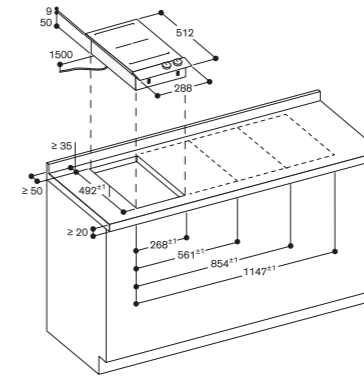

VG 295 150IN

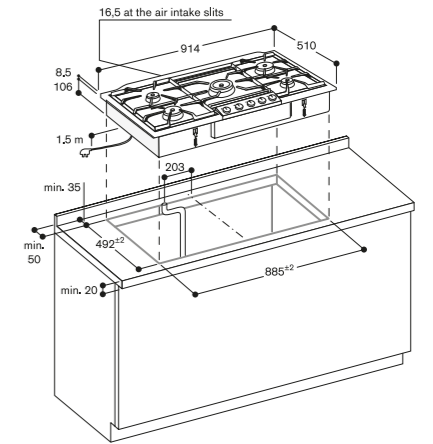

VG 425 111IN

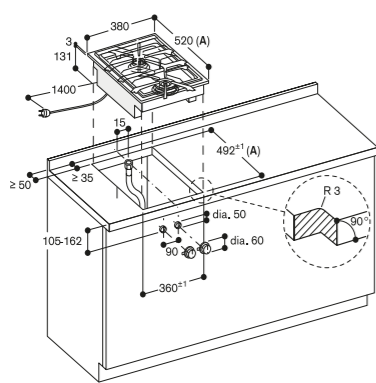

VG 415 111IN

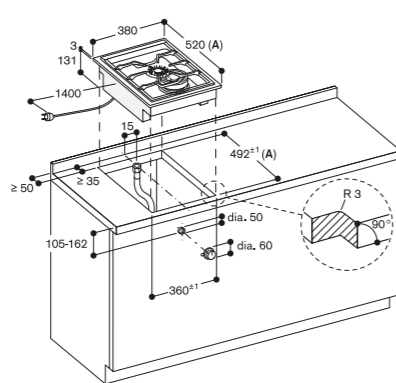

VP 414 115

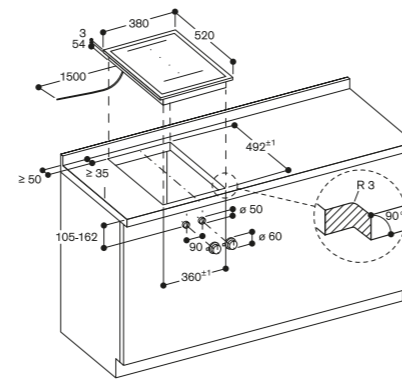

VG 264 120IN

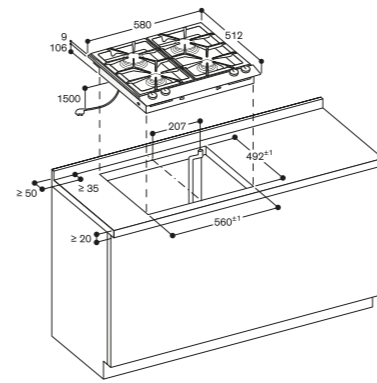

VG 232 120IN

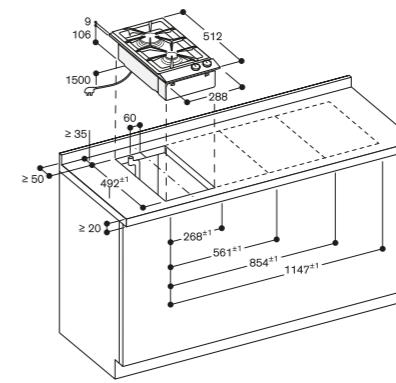

VG 231 120IN

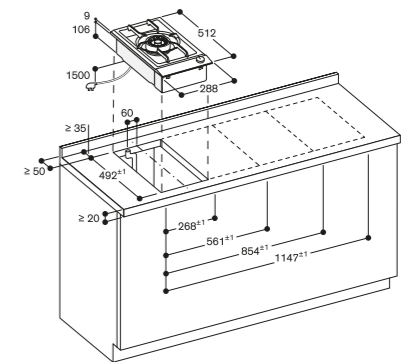

VR 414 115

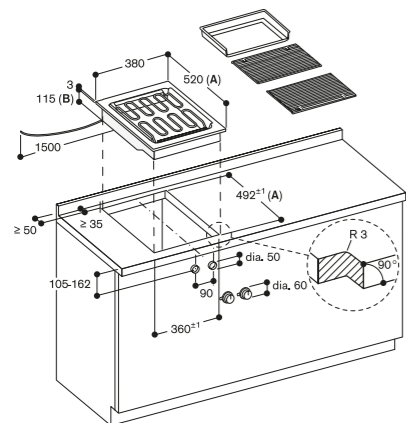

VP 230 120

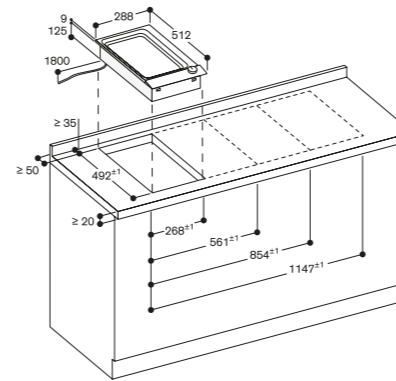

VR 230 120

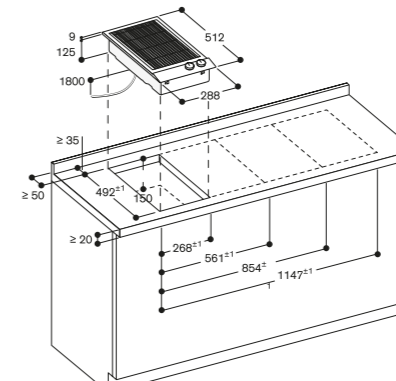

Cooling 400 series

Technical Drawings

Cooling 400 series

Technical Drawings

RC 492 304

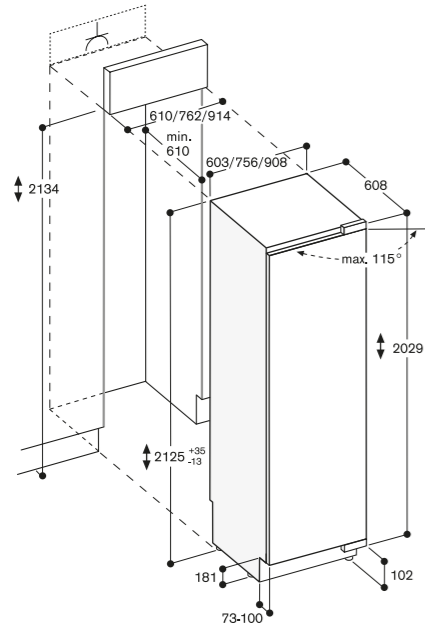

RC 472 304

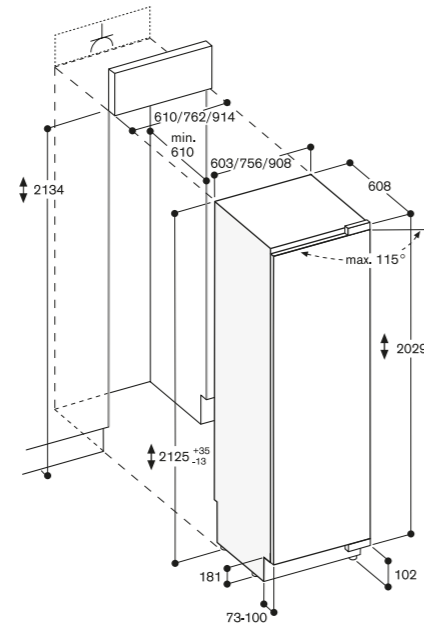

RC 462 304

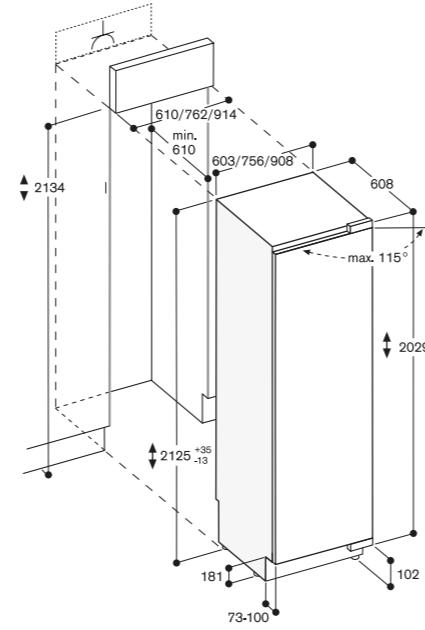

RF 463 305

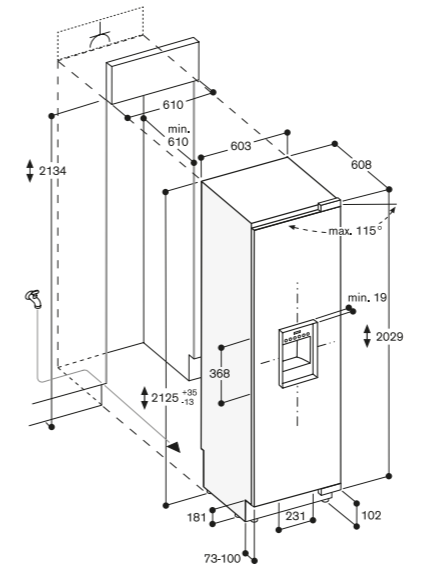

RF 471 304

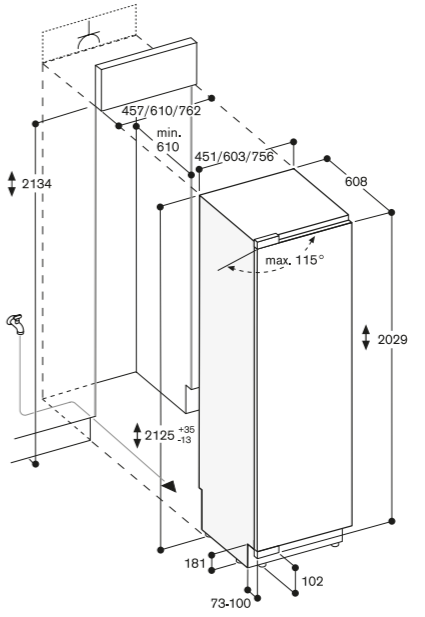

RF 411 304

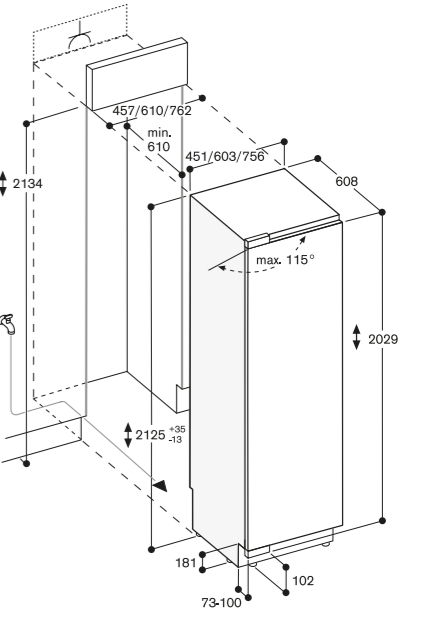

RB 492 305

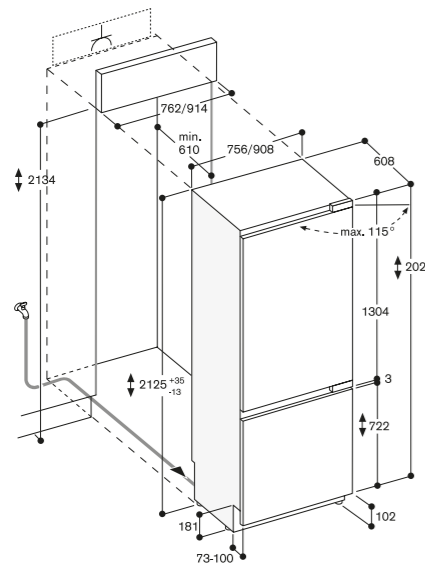

RB 472 305

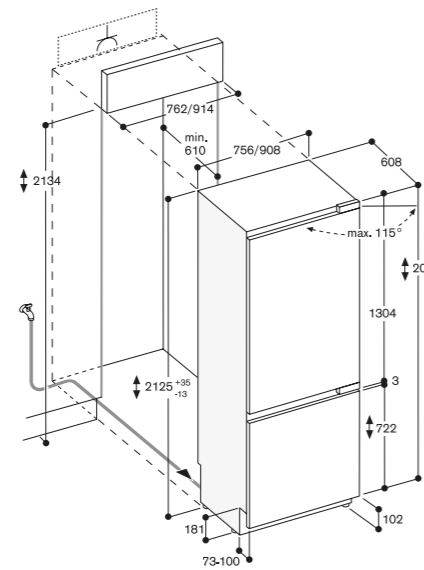

RF 461 304

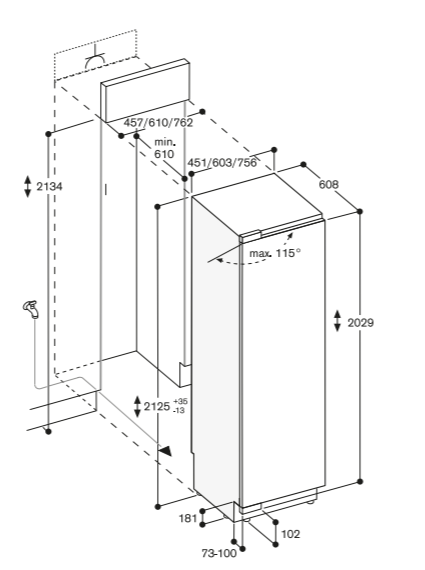

RW 466 364

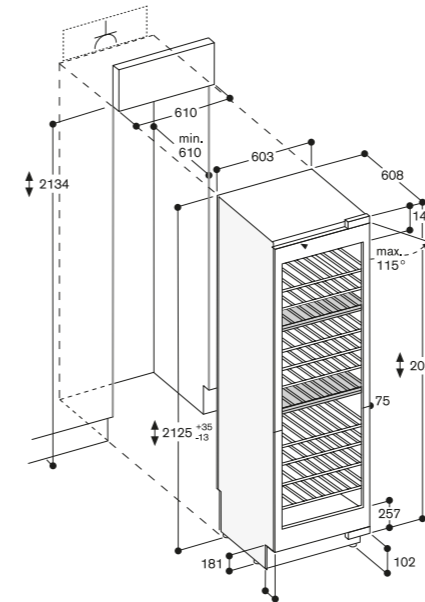

RW 414 364

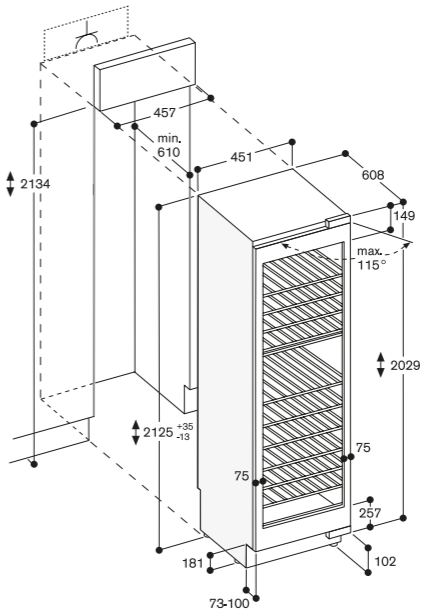

Dishwasher 200 series

Technical Drawings

DF 270 101F

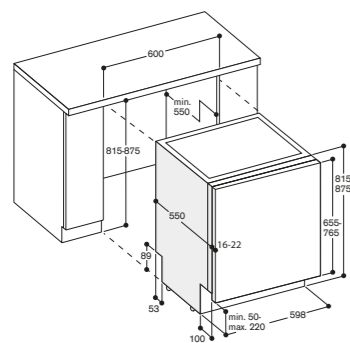

Energy Labels

By using energy-saving home appliances, you save valuable resources as well as money. That's why you should consider low energy and water consumption values when you purchase a home appliance.

Technological developments have resulted in many more products being able to attain an A+ or better rating. User behaviour has also changed, which is why new rescaled labels have been created that take this into account for washing machines, washer-dryers, dishwashers, cooling appliances and wine coolers. The Energy Label for ovens, cooktops and extractors will remain the same.

For more information on energy labels, visit: www.gaggenau.com

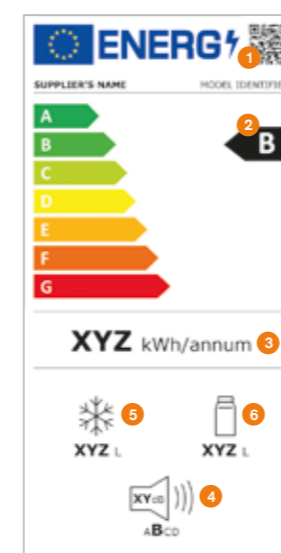

New rescaled energy label for washing machines, washer-dryers, dishwashers, cooling appliances and wine coolers.

Example Key for a fridge-freezer combination

- 1 QR code
- 2 Energy efficiency class
- 3 Energy consumption in kWh/year (measured under new standard conditions)
- 4 Noise emissions expressed in dB(A) re 1 PW and noise emission class
- 5 Total volume of all freezer compartments
- 6 Total volume of all refrigerator compartments

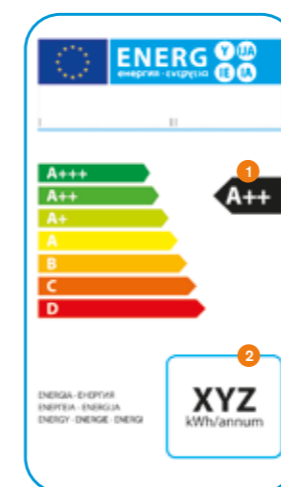

Energy label for oven, cooktops, extractors.

Key

- 1 Energy efficiency class
- 2 Energy consumption in kWh/year (measured under standard conditions)



The extraordinary is connected

Gaggenau and Home Connect.

Our lives and homes are becoming ever more connected. Our home appliances have always enabled our consumers to create extraordinary cuisine, now digital services are a valuable add-on to this principle as they integrate the kitchen into our modern lifestyles.

Our appliances are being equipped with Home Connect, a platform allowing you to intuitively communicate with your appliance digitally, remotely and at will. Home Connect also offers a wide range of other advantages such as remote diagnostics, voice control, and integration into selected home management systems.

Home Connect, enhancing your time in, and away from, the kitchen. Explore more possibilities on our website.



Download App from Apple App Store (iOS)



Download App from Google Play Store (Android)



The use of the Home Connect functionality depends on the Home Connect services, which are not available in every country. For further information please check: home-connect.com
Home Connect is a service of Home Connect GmbH.

Showrooms

Our 60 showrooms await, simply arrange your appointment to experience our world.

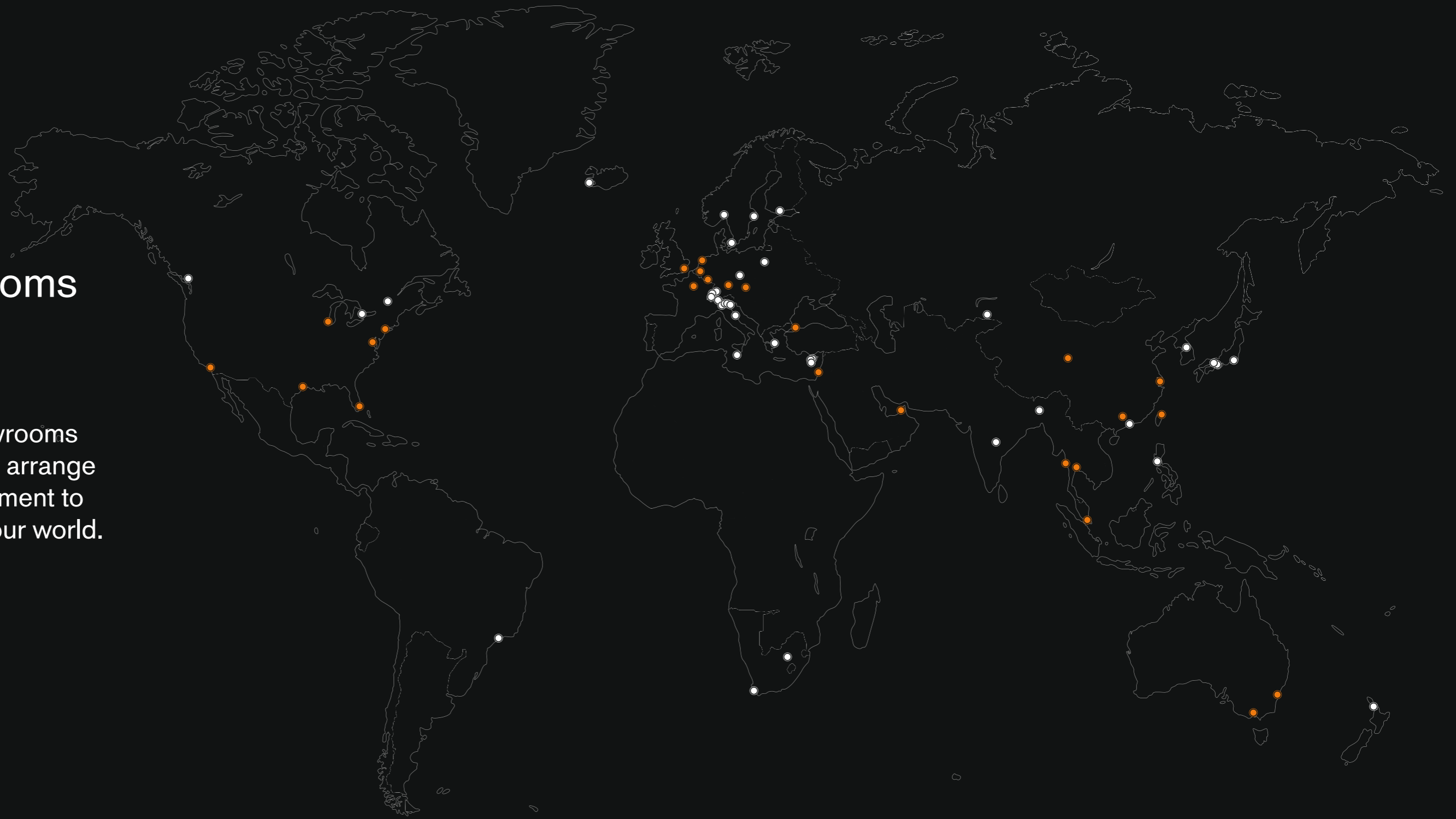

● Flagship
● Showroom

Locations in orange are Gaggenau flagship showrooms. Please go to our website to find your nearest showroom or dealer.

Showrooms

Africa

South Africa

Cape Town Showroom
17 New Church Street
Bree Street Studios
8000 Cape Town
+27 21 550 9900

Johannesburg Showroom

30 Archimedes Street
Kramerville
2148 Johannesburg
+27 10 001 0019

Asia and
Middle East**Region Greater China**

Gaggenau Beijing
Room 5018
China World Tower
No. 1 Jian Guo Men Wai Street
Chaoyang District
100004 Beijing
+86 10 8535 1058

Gaggenau Chengdu

Room 4807-9
Office Tower 1
Chengdu IFS No.1, section 3
Hongxing Road
610021 Chengdu
Sichuan province
+86 028 8609 3656

Gaggenau Guangzhou

Room 5203
Guangzhou International
Finance Center
No.5 Zhujiang Road West
Zhujiang New Town
510623 Guangzhou
Guangdong
+86 20 2338 8958

Gaggenau Shanghai

Jing'an District
Weihai Road No.299
200040 Shanghai
+86 21 3229 0368

Hong Kong Showroom

Kitchen Infinity Corp. Ltd.
Lippo Leighton Tower
Shop B, G/F
103 Leighton Rd
Causeway Bay
Hong Kong
+852 2882 1152

Gaggenau Taipei

BSH Home Appliances
Pte. Ltd.
11F No. 80 Zhouzi Street
Neihu District
Taipei City 11493
+886 2 8978 0999

India

Gaggenau Hyderabad
BSH Household Appliances
Manufacturing Pvt. Ltd.
G square, 1st floor, Madhura
Nagar colony, Gachibowli
Hyderabad - 500032
Telephone : 080-67521111

Gaggenau Kolkata

BSH Household Appliances
Manufacturing Pvt. Ltd.
Adventz Infinity @ 5, Sector
V ,BN Block , Unit No. 809
& 810, Kolkata : 700091
Telephone : +91 72782 11525

Israel

Gaggenau Tel-Aviv
BSH Home Appliances Ltd.
25 Maskit Street
46733 Herzliya
+972 9973 0000

Japan

Ashiya Showroom
N.TEC Co. Ltd.
6-16 Ohara-cho
Ashiya-shi Hyogo 651-0092
+81 797 32 3751

Hyogo Showroom

N.TEC Co. Ltd.
2-23-7 Narai Yamaguchi-cho
Nishinomiya-shi Hyogo
651-1411
+81 78 904 3101

Tokyo Showroom

N.TEC Co.Ltd
1-8-4 Higashiazabu
Minato-ku
Tokyo 106-0044
+81 3 5545 3877

Kazakhstan

Almaty Showroom
Azimut TOO
Prospekt Abai, 31
50000 Almaty
+7 372 7258 2931

Philippines

Metro Manila Showroom
Living Innovations Corp
GF Units 106 & 107
Fort Victoria 5th Ave. corner
Rizal Drive Fort Bonifacio
Global City
Taguig City
Metro Manila
+62 2 830 2230

Singapore

Gaggenau Singapore
BSH Home Appliances
Pte. Ltd.
11 Bishan Street 21
4th Floor
Singapore 573943
+65 6356 1080

South Korea

Seoul Showroom
Fine Appliances Co. Ltd.
3rd Fl. Jinnex Lakeview Bldg.
99, Ogeumno Songpa-gu
Seoul 05548
+82 2 6293 9393 (ext. 402)

Thailand

Gaggenau Bangkok
BSH Home Appliances Ltd.
Ital Thai Tower
No. 2034/31-39
2nd Floor
New Petchburi Road
Bangkapi
Huay Kwang
Bangkok 10310
+66 2012 7959

United Arab Emirates

Gaggenau Dubai
The Oberoi Centre
Level 5, 504
P.O. Box 71847 Business
Bay, Dubai
+971 4 380 7167

Europe

Austria

Gaggenau Vienna
Stilarena
Quellenstraße 2a
1100 Vienna
+43 1 60 5750

Belgium

Gaggenau Brussels
BSH Home Appliances
N.V.-S.A.
Gare Maritime
Rue Picard straat 7 Box 400
1000 Brussels
+32 2 475 7219

Czech Republic

Prague Showroom
BSH domácí spotřebiče
s. r. o.
Radlická 350/107c
158 00 Praha 5
+420 251 095 550

Cyprus

Lefkosa Showroom
Akbel Ltd.
14A Ortaköy
Dr. Burhan Nalbantoğlu Cad
00010 Lefkosa
+90 39 2223 3233

Limassol Showroom

Lazanias Store
5, Thessalonikis Street
Nicolau Pentadromos
Center
3025 Limassol
+357 2534 2023

Nicosia Showroom

Hadjikyriakos & Sons Ltd.
121, Prodromos Street
1511 Nicosia
+357 2287 2111

Denmark

Copenhagen Showroom
BSH Hvidevarer A/S
Telegrafvej 4
2750 Ballerup
+45 4489 8833

Finland

Helsinki Showroom
BSH Kodinkoneet Oy
Itälahdenkatu 18 A
00201 Helsinki
+358 20 751 0750

France

Gaggenau Paris
240, Blvd Saint Germain,
75007 Paris
+33 1 5805 2020

Germany

Gaggenau Munich
Arabellastraße 30 A
81925 Munich
+49 89 4510 4647

Greece

Athens Showroom
17th km EO Athinon Lamias
& Potamou 20
14564 Kifissia
+30 210 4277 827

Iceland

Reykjavik Showroom
Smith & Norland hf.
Nóatúni 4
105 Reykjavik
+354 520 3000

Italy

Macerata Showroom
Design Elementi
Marche S.r.l.
Via delle Maestranze 1
Zona Ind. le Corridonia
62014 Corridonia
+39 0733 28 3526

Milan Showroom

Design Elementi
Milano S.r.l.
Corso Magenta 2
20121 Milan

Rome Showroom

Design Elementi
Lungotevere de' Cenci 4
00186 Roma
+39 06 39743229

Treviso Showroom

F.K. & T. S.r.l - Furniture
Kitchen and Technology
Piazza Foro Romano 2
31040 Oderzo
+39 0422 81 5110

Verona Showroom

Nuova Arredo
Inserimenti S.r.l.
Via Roveggia 122
37100 Verona
+39 045 58 3234

Vicenza Showroom

Nuova Arredo Inserimenti
Via Dell'Industria 48/50
36040 Grisignano
Di Zocco
+39 0444 61 4422

Malta

Malta Showroom
Aplan Ltd.
The Atrium
Mriehel By-Pass
Birkirkara BKR 3000
Malta
+356 2148 0590

Netherlands

Gaggenau Amsterdam
Inspiratiehuis 20|20
Taurusavenue 36
2132 LS Hoofddorp
+31 88 424 4031

Norway

Oslo Showroom
BSH
Husholdningsapparater AS
Brynsveien 18
0607 Oslo
+47 2266 0646

Poland

Gaggenau Warsaw
BSH Sprzet
Gospodarstwa Domowego
Sp. z o.o.
Aleje Jerozolimskie 183
02-222 Warszawa
+48 22 572 4400

Sweden

Gaggenau Stockholm
BSH Home Appliances AB
Landsvägen 32
169 29 Solna
+46 8 734 1370

Switzerland

Bern Showroom
BSH Hausgeräte AG
Laupenstrasse 20
3008 Bern
+41 848 888 200

Lausanne Showroom

BSH Electroménager SA
Chemin de Mongevon 4
1023 Crissier
+41 848 777 500

Lugano Showroom

BSH Elettrodomestici SA
Via Campagna 30
6934 Bioggio
+41 848 777 500

Zurich Showroom

BSH Hausgeräte AG
Fahrweidstr. 80
8954 Geroldswil
+41 848 777 500

Turkey

Gaggenau Istanbul
Istanbul Sapphire
Residence, 3206
Eski Büyükdere Caddesi
34330 Levent
Istanbul
+90 21 2397 2012

United Kingdom

Gaggenau London
40 Wigmore Street
London
W1U 2RX
+44 344 892 8988

Showrooms

North America

Canada

Montréal Showroom
L'Atelier BSH
61 Rue Peel
Montréal, QC, H3C 0W3
+1 514 353 3232

Toronto Showroom
Luxe Appliance Studio
334 King Street East
Toronto, ON, M5A 1K8
+1 888 966 5893

Vancouver Showroom
Luxe Appliance Studio
30 East 6th Avenue
Vancouver, BC, V5T 1J3

USA

Gaggenau Beverly Hills
"Coming Soon"
257 North Canon Drive
Beverly Hills, 90210

Gaggenau Chicago
Merchandise Mart
222 Merchandise Mart Plaza
Suite 108
Chicago, IL 60654
+1 312 832 3200

Gaggenau Houston
"Coming Soon"
1751 Post Oak Blvd
Houston, TX 77056

Gaggenau Irvine
17911 Von Karman
Suite 100
Irvine, CA 92614
+1 949 224 4700

Gaggenau Miami
112 Northeast 41st Street
7th Floor
Miami, FL 33137
+1 561 980 4610

Gaggenau New York

A&D Building, 7th Floor
150 East 58th Street
New York, NY 10155
+1 21 2588 0950

Gaggenau Washington D.C.

"Coming Soon"
940 New York Avenue NW
Washington, DC 20001

South America

Brazil

São Paulo Showroom
Boutik Skok
Al. Gabriel Monteiro
da Silva 488
01442-000 Jardins
São Paulo
Brazil
+55 11 3668 6600

Oceania

Australia

Gaggenau Melbourne
192-196 Coventry Street
South Melbourne
Victoria 3205
+61 3 9690 3123

Gaggenau Sydney
543 Crown Street
Surry Hills, Sydney
NSW 2010

New Zealand

Auckland Showroom
UnserHaus
65 Parnell Rise
Parnell
Auckland 1052
+64 9 477 3530