

Electronic Hob

CE 491

CE 492

Table of contents

Safety notes	4	Automatic quick boil function	16
Before use	4	Switching on the automatic quick boil function	16
Safety when cooking	4	Switching off the automatic quick boil function	16
Removable twist knob	4		
Damage to the hob	4		
Operating for the first time	5		
Causes of damage	5	Child lock	17
Pots and pans	5	Activating the child lock	17
Food spills	5	Operating the hob	17
Scratches on the glass ceramic	5	Deactivating the child lock	17
Twist knob	5	Single locking of the hob	17
Hard and pointed objects	5	Unlocking the hob	17
Features of your new hob	6	Additional functions	18
Cooking zones	6	Switching off the confirmation tone	18
Control panel	7	Holiday safeguard	18
Special accessories	7		
Operating principle	8	Memory cooking	19
Main switch	8	Operating principle	19
Control panels	8	Storing the setting	19
Twist pad with magnetic twist knob	8	Notes	19
Storing the twist knob	8	Changing the setting	20
Cooking zone extension	8	Calling up the memory	20
Residual heat display	8	Displaying the memory	20
		Memory ends	20
Operation	9	Ending the memory prematurely	20
Switching on and off	9	Several cooking zones in memory operation	20
Setting the cooking level	9		
Changing the cooking level	9	Cleaning and care	21
Switching off a cooking zone	9	Cleaning the glass ceramic	21
Main switch with memory function	10	Cleaning the stainless steel frame (only CE 491)	21
Residual heat display	10	Cleaning the twist knob	21
Tips on saving energy	10		
Cooking zone extension	11	Useful hints	22
Extension of the dual size cooking zone	11		
Extension of the triple size cooking zone	11	Maintenance	22
Extension of the roasting zone	12		
Deactivating extension	12	Trouble shooting	23
Note	12		
Settings table	13		
Timer	14		
Setting an automatic switch-off time	14		
Changing a time value	14		
Erasing a time value	14		
Notes	14		
Setting the timer	15		
Changing a time value	15		
Note	15		



Safety notes

Before use

Read the instruction manual carefully before operating the hob. Only then will you be able to operate your hob safely and correctly. Keep the instruction and installation manual for future reference.

Do not connect the hob if it has been damaged.

This hob is intended only for domestic use. Only use the hob to prepare meals. Do not use the hob to heat up the room in which it is installed, the hob can overheat.

Connecting cables from electrical appliances must not touch the hot cooking surface. This could cause damage to the cable insulation and the hob.

Caution, risk of fire! Never place inflammable items on the hob.

Caution, risk of fire! Do not store any combustible items, or substances that are sensitive to high temperatures, in drawers or cupboards under the hob (e.g. cleaning agents, aerosol cans).

Safety when cooking

Caution, risk of burns! Do not touch the hot cooking surface. Keep children away.

Caution, risk of burns! Cooking zones might still be hot even after being switched off. Only touch cooking zones after the residual heat display has gone off.

Caution, risk of fire! Overheated oil or fat can ignite very quickly. Never leave heating oil or fat unsupervised. Never pour water on burning oil. Cover pan with lid or plate, switch off the cooking zone. Leave the ovenware on the hob to cool down.

Always keep hob and pan base dry. Steam pressure can be generated from liquid between pan base and hob. The steam pressure could cause the pan to jump suddenly.

Removable twist knob

Caution! For persons who wear electronic implants such as a pacemaker or insulin pump. Implants could be affected by magnetic fields. Do not carry the twist knob in the pockets of your clothing. Keep the twist knob at least 10 cm away from a pacemaker.

Damage to the hob

Caution! If there are fractures, breaks or cracks in the glass ceramic, there is a risk of electric shock. Switch off the corresponding household fuse. Call after-sales service.

Caution, risk of burns! Switch off the cooking zone if it heats up but the indicator is not working. Call after-sales service.

Caution, risk of fire! If the hob switches itself off and can no longer be operated, disconnect it from the electricity supply immediately. The hob could switch itself on later. Switch off the corresponding household fuse. Call after-sales service.

Incorrect repairs are dangerous. Repairs must be carried out by one of our experienced after-sales engineers.

Operating for the first time

Remove the packaging from the appliance and dispose of it according to local regulations. Be careful to remove all accessories from the packaging. Keep packaging elements and plastic bags away from children.

Check the hob for transport damage after unpacking it. Do not connect the hob if it has been damaged.

The hob must be installed and connected by an authorised specialist. No warranty claims can be lodged for any damage resulting from incorrect connection. Observe the installation instructions.



This appliance is labelled in accordance with the European Directive 2002/96/EG concerning used electrical and electronic appliances (waste electrical and electronic equipment – WEEE). The guideline determines the framework for the return and recycling of used appliances as applicable.

Thoroughly clean the appliance before using it for the first time. This will eliminate any 'newness' smells and soiling.

Causes of damage

Pots and pans

Rough pan bases scratch the glass ceramic.

Avoid cooking on the hob with an empty pan, especially with enamel or aluminium pans. This could cause damage to the pan base and the glass ceramic.

Do not place hot pots or pans on the control panel, display area or the frame. This could cause damage.

Never heat food in aluminium foil or plastic containers. The material can melt and damage your hob.

Iridescent discoloration can be caused by the bases of some pans. These do not interfere with the operation of the glass ceramic hob. Remove the discoloration with glass ceramic cleaner.

Food spills

Milk, sugar and food with a high sugar content (e.g. jam) damage the glass ceramic surface. Remove food spills immediately with the glass scraper. Caution! The glass scraper has a sharp blade.

Scratches on the glass ceramic

Always keep the hob dry and clean. Salt, sugar and sand cause scratches on the glass ceramic. Do not use the hob as a work surface or storage space.

Twist knob

Do not place the twist knob on the cooking zones. It could be damaged.

Metal parts attached to the underside of the magnetic twist knob could scratch the glass ceramic surface. Always keep the twist knob clean.

Hard and pointed objects

Damage can occur if hard or pointed objects fall on the hob. Do not store such objects above the hob.

Features of your new hob

CE 491 is supplied with a stainless steel frame.
CE 492 is suitable for flush mounting into stone worktops. The operation of both types is identical.

Cooking zones

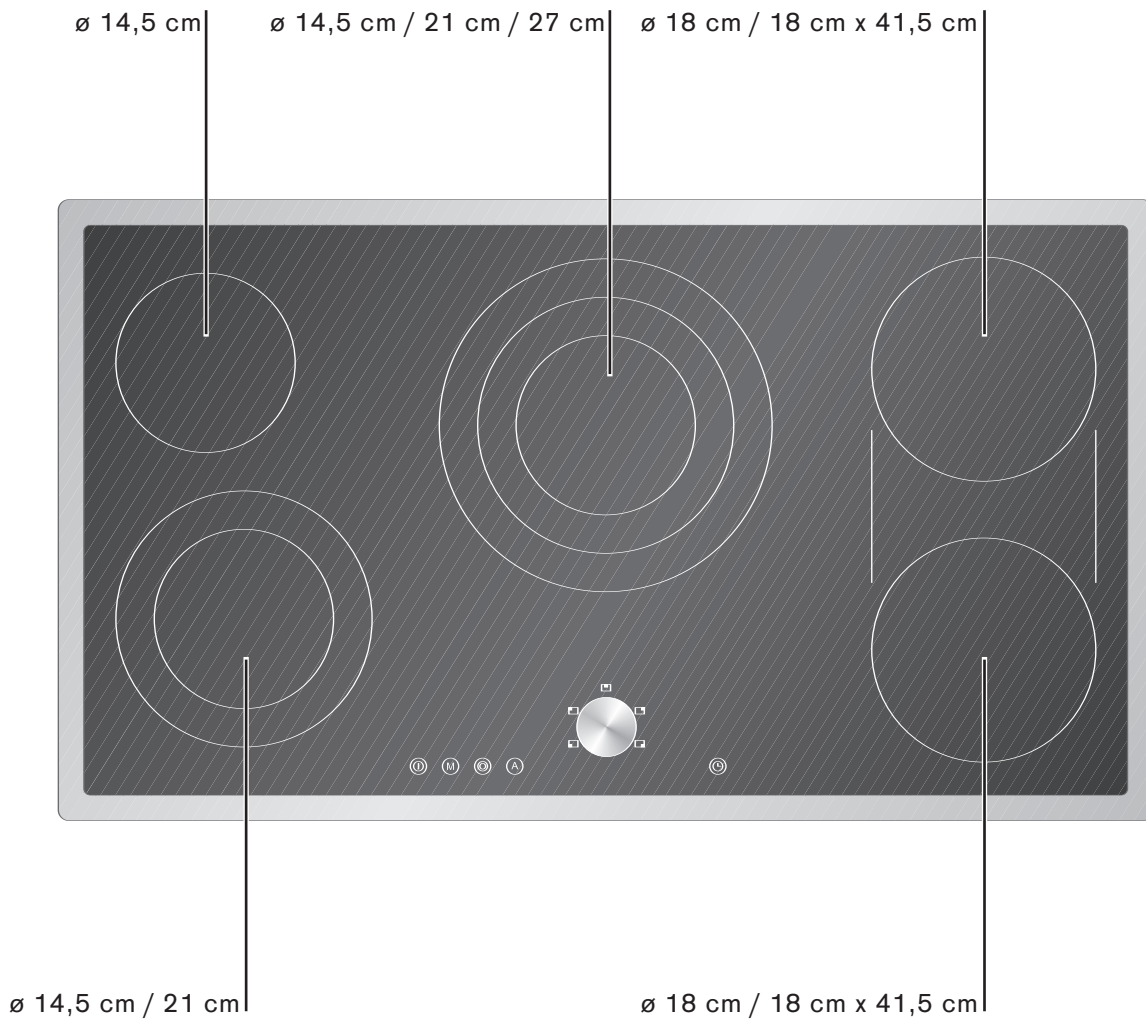

Control panel

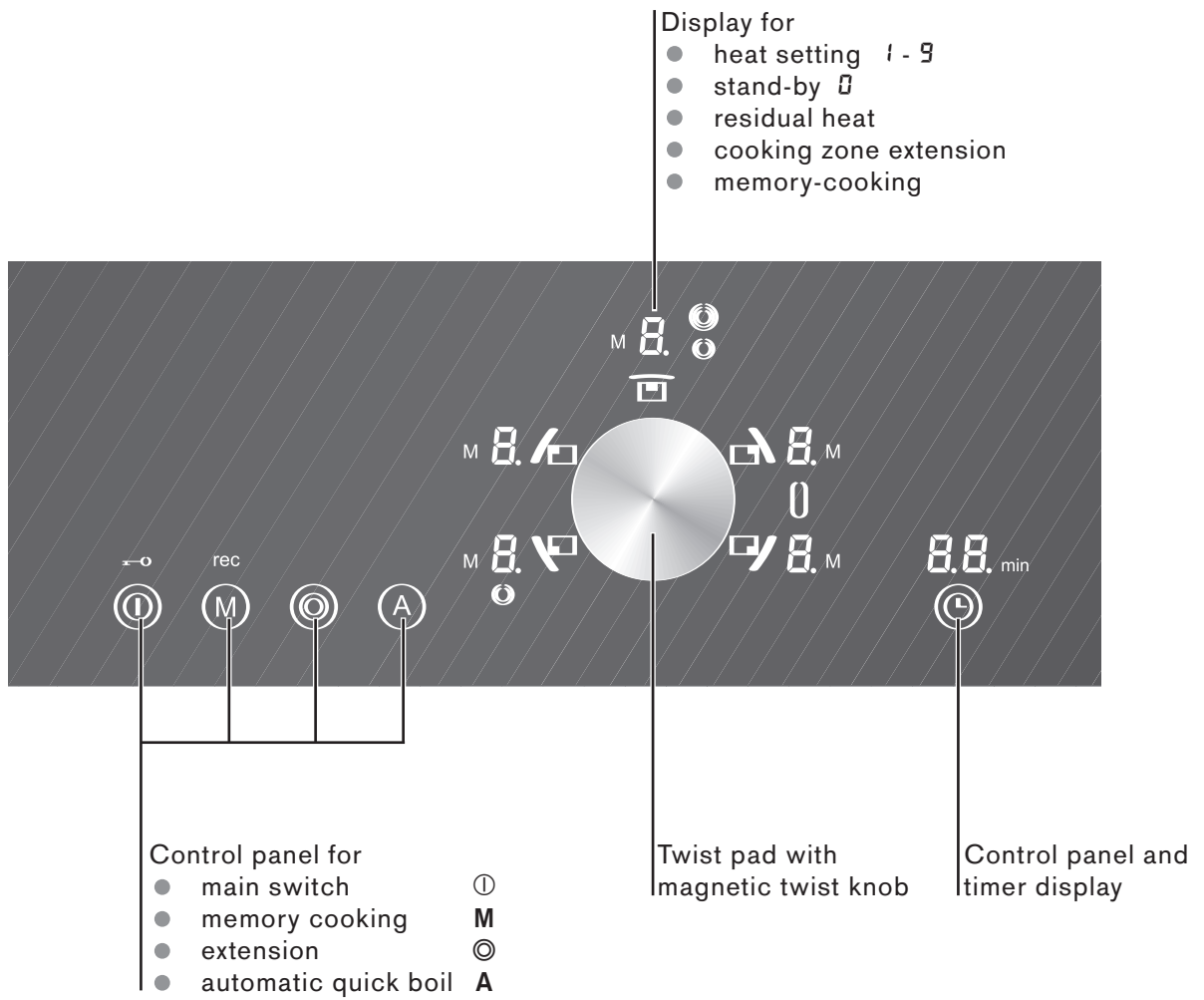

Special accessories

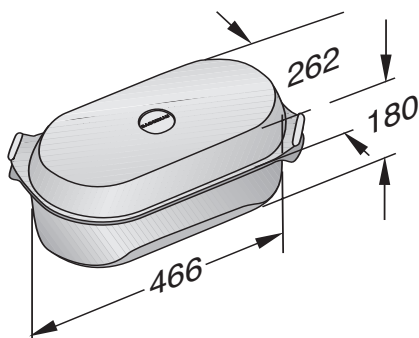

You can order the following special accessories:

- **BT 481-000:** Cast aluminium roaster with lid, non-stick coated, suitable for the roasting zone 18 x 41,5 cm.

Operating principle

Main switch

The electronics in the control panel are switched on using the main switch. Touch the ① symbol until the cooking zone displays show . Now the hob is ready for use.

Touch the ① symbol until the cooking zone displays go off. All the cooking zones are switched off. The residual heat indicator remains lit until the cooking zones have cooled sufficiently.

Note: The hob switches off automatically if all the cooking zones have been switched off for more than 10 seconds.

Control panels

When you touch a symbol, the respective function is activated. Every input is confirmed by an audible signal.

Note: The settings remain unchanged if several symbols are touched briefly. You can therefore easily mop up spills on the control panel.

Note : Always keep the control panels clean and dry. Moisture and dirt may impair function.

Twist pad with magnetic twist knob

The twist pad is the area in which you select the cooking zones with the twist knob and can set heat settings. The twist knob automatically centres itself in the twist pad.

The twist knob is magnetic and is placed on the twist pad. The cooking zone is activated by sliding the twist knob in the direction of the corresponding cooking zone symbol. You can set the heat setting by turning the twist knob.

You can remove the twist knob. This makes cleaning easier.

If you remove the twist knob when the hob is in operation, all the cooking zones switch off after 3 seconds.



Caution! If you place a metal object on the twist pad within 3 seconds, the hob may continue to heat up. For this reason, always switch off the hob using the main switch.

Storing the twist knob

There is a strong magnet in the twist knob. Do not, therefore, place it near magnetic data carriers, e.g. video cassettes, disks, credit cards and cards with magnetic strips. These could be destroyed. Malfunctions to televisions and monitors may occur.



Caution! For persons who wear electronic implants such as a pacemaker or insulin pump.

Implants could be affected by magnetic fields. Do not carry the twist knob in the pockets of your clothing. Keep the twist knob at least 10 cm away from a pacemaker.

Cooking zone extension

The size of the front left and the middle cooking zones can be altered by activating the cooking zone extension.

Both right cooking zones convert together with an additional zone, to create an oval roasting zone especially suitable for the Gaggenau cast roaster.

Residual heat display

The residual heat display appears on the display of the relevant cooking zone after switching off. The moving zero in the display indicates that, after switching off, a cooking zone has still not cooled down to such an extent that it can be safely touched.



Caution, risk of burns! Only touch cooking zones after the residual heat display has gone off.



Caution, risk of burns! The residual heat display stays off after a power cut. The cooking zones may still be hot.

Operation

Switching on and off

Touch the ① main switch symbol. A signal is sounded. The cooking zone displays show 0. Now the hob is ready for use.

The hob switches off automatically if no further inputs are made within approximately 10 seconds.

By touching the main switch symbol at any time the hob can be quickly switched off.

Setting the cooking level

The hob must be switched on by the main switch. The switching on and off for all cooking zones is identical. Each cooking zone has 9 heat settings with intermediate settings.

- 1 Select the cooking zone. To do this, slide the twist knob in the direction of the corresponding cooking zone symbol. The indicator light comes on and 0 flashes in the cooking zone display.
- 2 Move the twist knob back to the centre.
- 3 Within the next 5 seconds, turn the twist knob until the desired cooking level flashes in the display. If you select an intermediate setting, a spot appears next to the cooking level. The cooking level display lights up permanently after 5 seconds and the indicator light goes out.

Changing the cooking level

Select the cooking zone. Turn the twist knob to the desired cooking level.

Switching off a cooking zone

Select the cooking zone. Turn the twist knob to 0. The cooking zone is switched off, and the residual heat display appears after approximately 5 seconds.

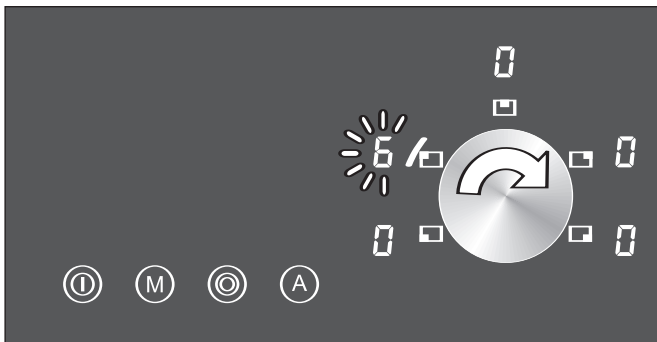
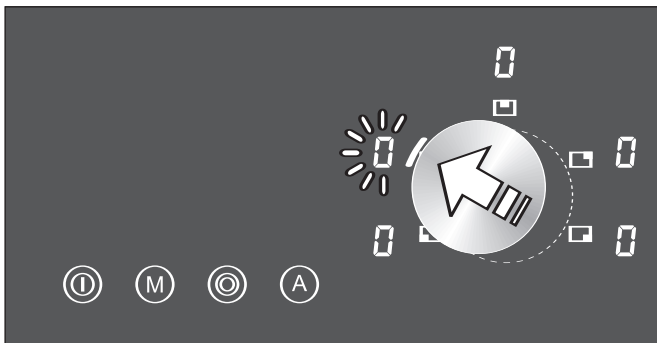
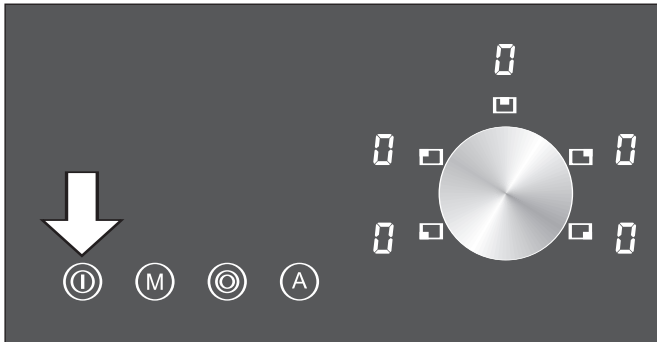

Main switch with memory function

The heating and timer settings remain stored for 5 seconds after the hob has been switched off.

If you switch the hob on again within 5 seconds after having switched it off accidentally, the hob will operate using the previously stored settings.

Residual heat display

The residual heat display appears on the display of the relevant cooking zone after switching off. The moving zero in the display indicates that, after switching off, a cooking zone has still not cooled down to such an extent that it can be safely touched.



Caution, risk of burns! Only touch cooking zones after the residual heat display has gone off.

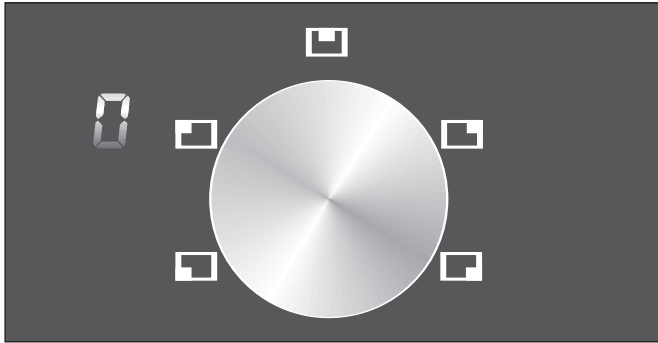

Tips on saving energy

Use good quality saucepans and pots with thick, even bases.

Select the correct saucepan size for each cooking zone. The diameter of the bases of the saucepans and pots should match the size of the cooking zone. Note: Ovenware manufacturers often give the diameter of the top of the saucepan. It is usually larger than the diameter of the base of the saucepan.

Use a small saucepan for small quantities. A larger, less full saucepan requires more energy.

Saucepans and pots should always be covered with a suitable lid to shorten cooking times. Cooking without a lid requires much more energy.

Cook with small quantities of water. This saves energy and helps vegetables to retain vitamins and minerals.

Switch down to a lower heat setting in good time.

For longer cooking times you can switch off the cooking zone before the end of the cooking time and then use the residual heat.

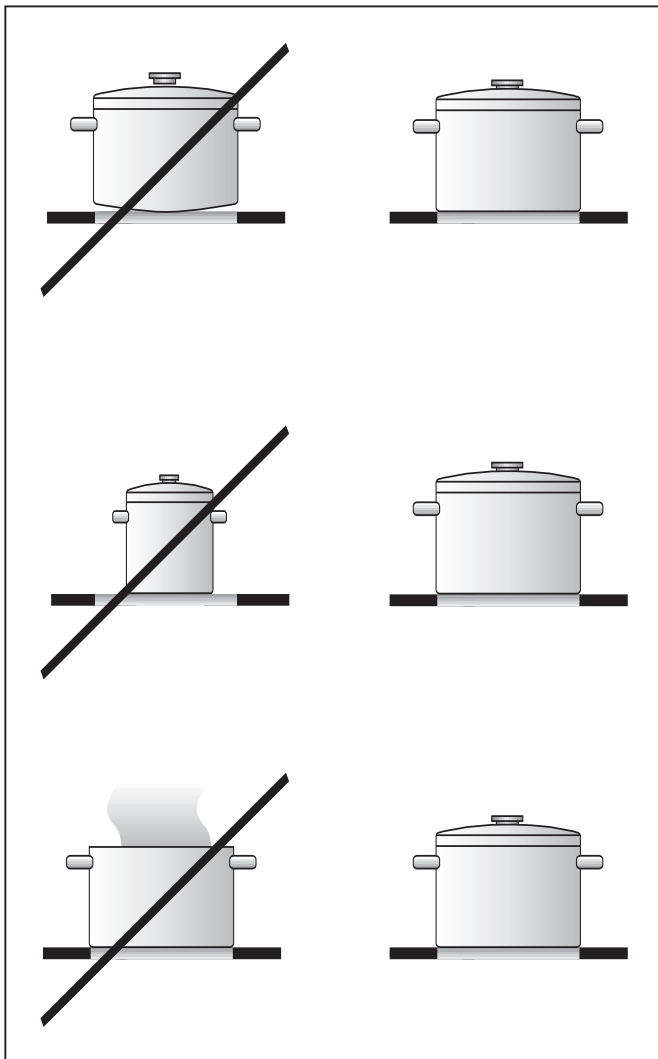



Cooking zone extension

Extension of the dual size cooking zone

The size of the front left cooking zone can be altered.

The hob must be switched on by the main switch.

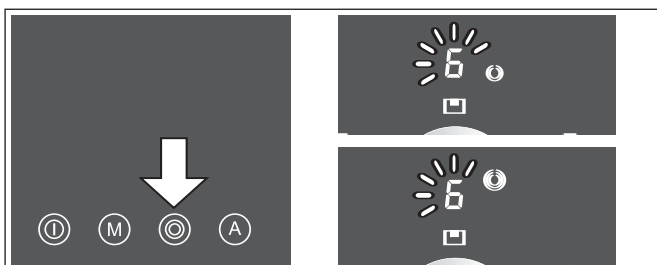
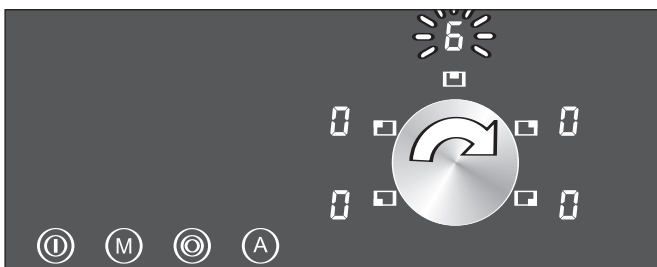
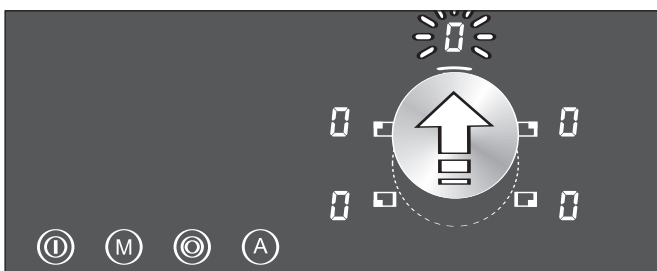
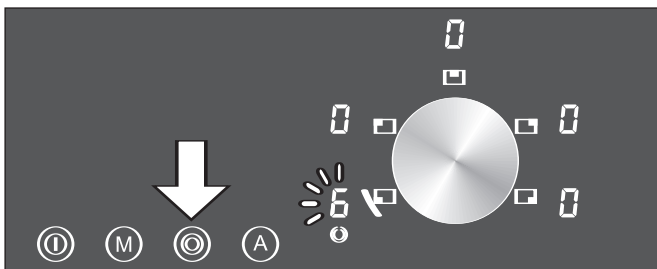
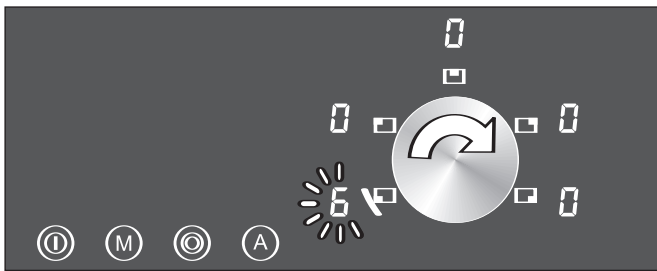
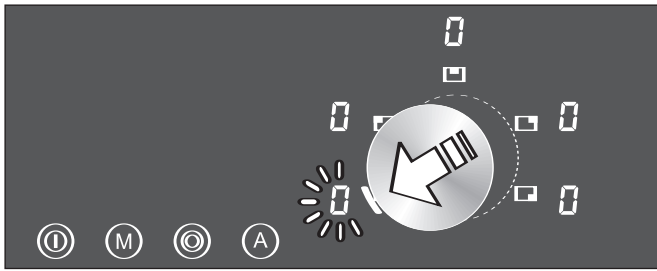

- 1 Select the cooking zone. To do this, slide the twist knob in the direction of the corresponding cooking zone symbol. The indicator light comes on and  flashes in the cooking zone display.
- 2 Move the twist knob back to the centre.
- 3 Within 5 seconds, turn the twist knob until the desired cooking level flashes in the display.
- 4 Within the next 5 seconds, touch the symbol  extension. The cooking level display lights up permanently after 5 seconds and the indicator light goes out. The extension symbol lights up under the cooking zone display.



Extension of the triple size cooking zone

The size of the middle cooking zone can be altered.

The hob must be switched on by the main switch.

- 1 Select the cooking zone. To do this, slide the twist knob in the direction of the corresponding cooking zone symbol. The indicator light comes on and  flashes in the cooking zone display.
- 2 Move the twist knob back to the centre.
- 3 Within 5 seconds, turn the twist knob until the desired cooking level flashes in the display.
- 4 Within the next 5 seconds, touch the symbol  extension. Touch the symbol several times to choose the required diameter. The cooking level display lights up permanently after 5 seconds and the indicator light goes out. The extension symbol lights up next to the cooking zone display.

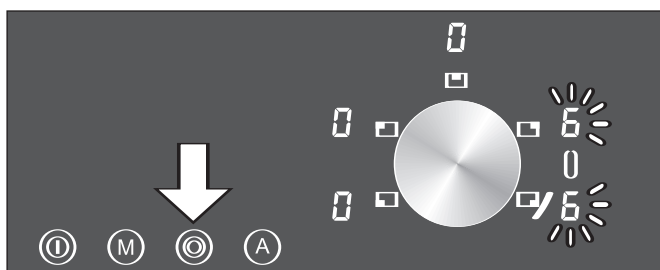
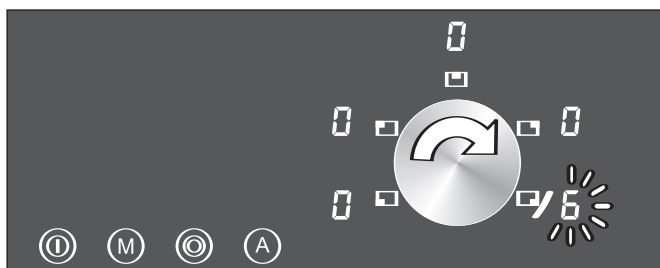
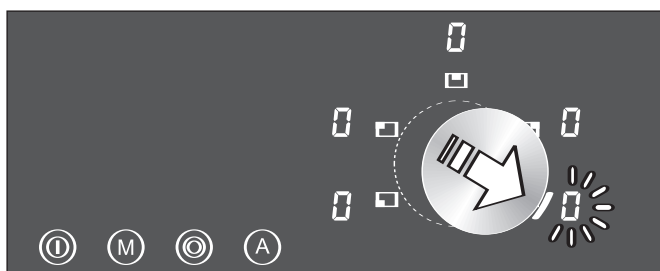



Extension of the roasting zone

Both right cooking zones convert together with an additional zone, to create an oval roasting zone especially suitable for the Gaggenau cast roaster.

When the extension is activated, both right cooking zones and the additional zone operate as one single cooking zone. Each input for one cooking zone will include both cooking zones and the additional zone.

The hob must be switched on by the main switch.

- 1 Select either of the right cooking zones. To do this, slide the twist knob in the direction of the corresponding cooking zone symbol. The indicator light comes on and  flashes in the cooking zone display.
- 2 Move the twist knob back to the centre.
- 3 Within 5 seconds, turn the twist knob until the desired cooking level flashes in the display.
- 4 Within the next 5 seconds, touch the symbol  extension. The cooking level displays of both cooking zones light up permanently after 5 seconds and the indicator lights go out. The extension symbol lights up between the two cooking zone displays.

Deactivating extension

Select the cooking zone. Within the next 5 seconds, touch the symbol  extension. The extension symbol goes out.

Note

When a cooking zone is switched on again, the previously used extension is activated.

Settings table

Cooking level	Cooking method	Examples
9	Boiling Searing Heating Boiling Blanching	Water Meat Fat, liquids Soup, sauce Vegetables
8 - 6	Roasting	Meat, fish, potatoes
7 - 6	Browning Roasting Baking Boiling in open pot	Flour, onions Almonds, breadcrumbs Pancakes, egg dishes Liquids
6 - 5	Frying Reducing	Bacon Stocks, sauces
5 - 4	Simmering Simmering in open pot	Sweet sauces Dumplings, sausages, soup garnish, meat stock, poached eggs
4 - 3	Boiling with closed lid Steaming Stewing Braising Thawing	Pasta, soup, sauces Vegetables, potatoes, fish Vegetables, fruit, fish Goulash, rolled beef steaks, roasts, vegetables Frozen foods
3 - 1	Slow cooking Reheating / keeping warm Melting Thickening	Rice, pulses Soup, casserole, vegetables in a sauce Butter, chocolate Egg dishes

Each cooking zone has 9 heat settings with intermediate settings. Switch to the highest cooking level in order to reach the required temperature quickly. Then always switch back to the lower cooking level.

The cooking levels are identical for all cooking zones.



The values given above must be looked upon as recommended values. The heat required depends not only on the type and condition of the food, but also the size and contents of the pot.

Timer



With the timer you can program an automatic switch-off time between 1 and 90 minutes in 1-minute-steps for a cooking zone (automatic switch-off). You can set a time value for every cooking zone.

Setting an automatic switch-off time

The hob must be switched on by the main switch.

- 1 Select the cooking zone with the twist knob.
- 2 Touch the  symbol.  flashes in the timer display. Use the twist knob to set the required duration. The duration flashes for several seconds and then begins to count down. If you have set a duration for several cooking zones, it is always the shortest duration that is displayed.



If you would like to call up the remaining duration for a cooking zone: Use the twist knob to select the cooking zone. The duration is displayed for 5 seconds.

When the duration has elapsed, the cooking zone switches off.  lights up in the cooking zone display. A signal sounds for three minutes.  flashes in the timer display. Touch any control panel. The displays will go out and the audible signal will stop.

Changing a time value

Select the cooking zone with the twist knob. Touch the  symbol. Use the twist knob to change the duration.

Erasing a time value

Select the cooking zone with the twist knob. Touch the  symbol. Use the twist knob to set the duration to . The display goes out after a few seconds. The cooking zone continues heating at the selected level.

Notes

The automatic switch off (holiday safeguard) can also be activated while using the timer function.

The timer function is no longer active after a power cut.

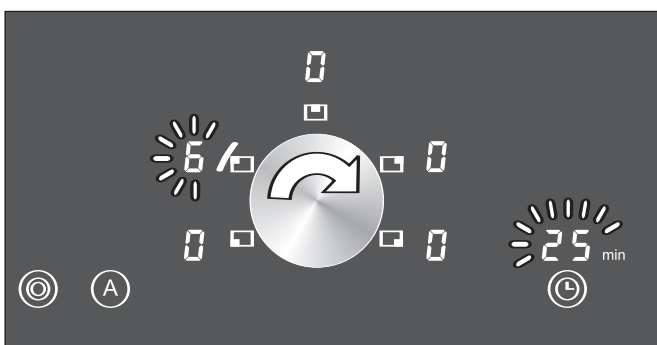
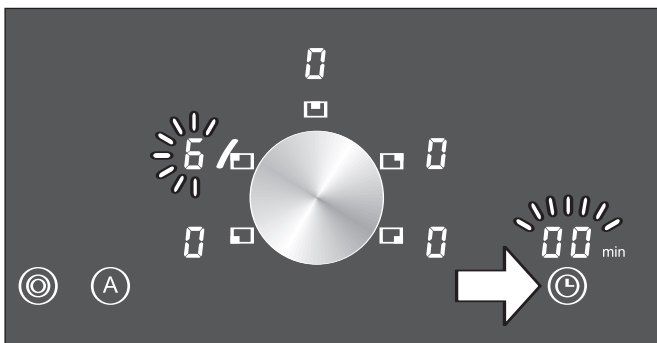
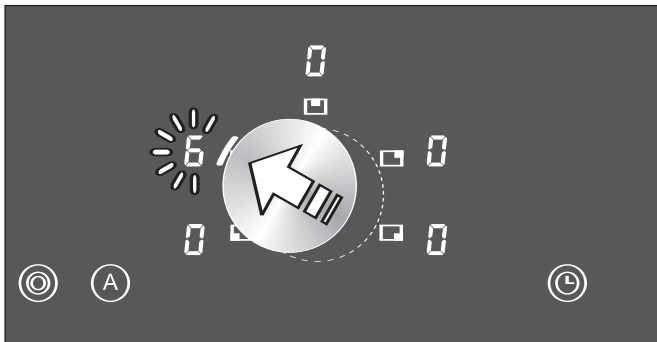

You can use the timer independently from the cooking zones and without switch-off function. The timer can also be used when the hob is switched off.

Setting the timer

No cooking zone should be selected.

- 1 Touch the ⌚ symbol, the **min** indicator flashes. 00 flashes in the timer display.
- 2 Use the twist knob to set the required duration. The duration flashes for several seconds and then begins to count down.

When the duration has elapsed, the **min** indicator flashes. A signal sounds for three minutes. 00 flashes in the timer display. Touch any control panel. The display will go out and the audible signal will stop.

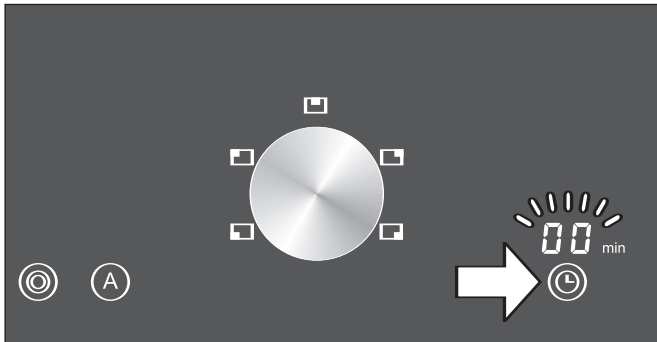

Changing a time value

Touch the ⌚ symbol. Use the twist knob to change the duration.

Note

The timer is no longer active after a power cut.

Automatic quick boil function

All cooking zones feature an automatic quick-boil function. When the automatic quick boil function is activated, the set cooking level is boosted for several minutes. This ensures that the continued cooking or simmering temperature of the food is reached faster.

The appliance switches automatically to the set simmering or cooking level after the quick boil time has elapsed. The length of the automatic quick-boil function depends on the selected cooking level.

Note: The automatic quick boil function cannot be activated when using cooking level 9.

Switching on the automatic quick boil function

The hob must be switched on by the main switch.

- 1 Select the cooking zone. To do this, slide the twist knob in the direction of the corresponding cooking zone symbol. The indicator light comes on and  flashes in the cooking zone display.
- 2 Move the twist knob back to the centre.
- 3 Within 5 seconds, turn the twist knob until the desired cooking level flashes in the display.
- 4 Within the next 5 seconds, touch the symbol **A** automatic quick boil. The display shows alternatively the chosen cooking level and "A". The indicator light goes off after 5 seconds.

Switching off the automatic quick boil function

It is possible to switch off the automatic quick boil function prematurely (e.g. because the food is boiling over).

- 1 Select the cooking zone. To do this, slide the twist knob in the direction of the corresponding cooking zone symbol. The indicator light comes on and the cooking zone display flashes.
- 2 Move the twist knob back to the centre.
- 3 Within 5 seconds, touch the symbol **A** automatic quick boil. The cooking level display lights up permanently after 5 seconds. The cooking zone switches back to the set cooking level.

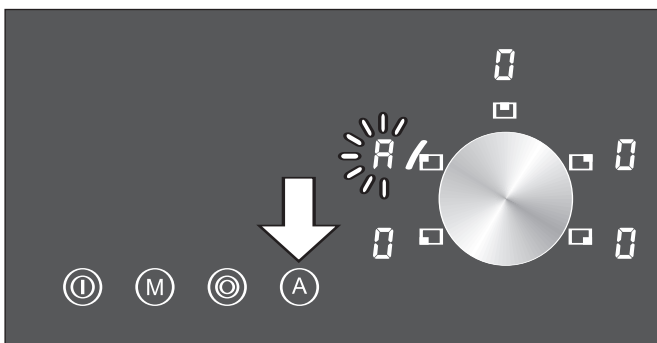
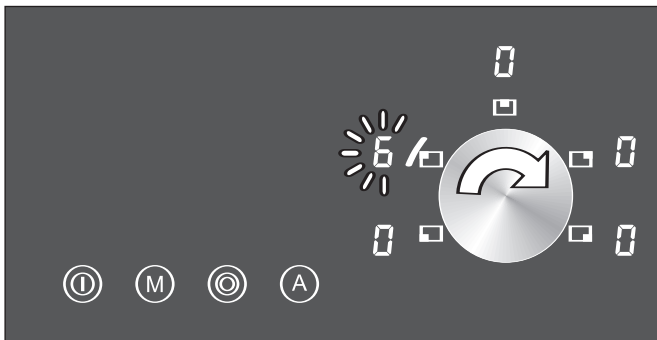
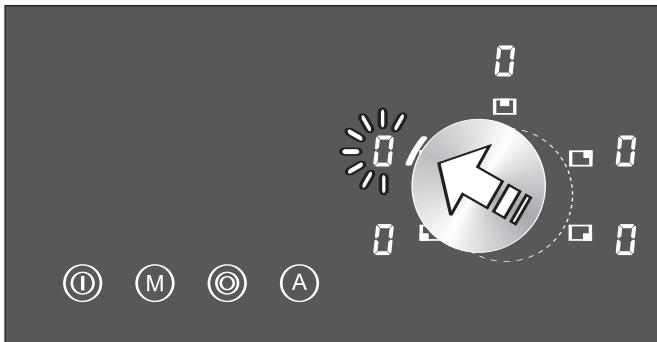

Child lock

You can prevent the hob from being switched on unintentionally so that children cannot switch on the cooking zones. The child lock remains activated permanently.

Note: The child lock could be activated or deactivated unintentionally when the appliance is cleaned using water or as a result of spillages or objects covering the main switch.

Activating the child lock

- 1 Switch on the hob using the main switch.
- 2 Set all cooking zones to heat setting 2.
- 3 Switch off the cooking zones one after the other, beginning with the front right cooking zone.
- 4 Touch the ① main switch for at least 5 seconds, after which time a confirmation signal will sound. The → symbol flashes. The child lock is activated.

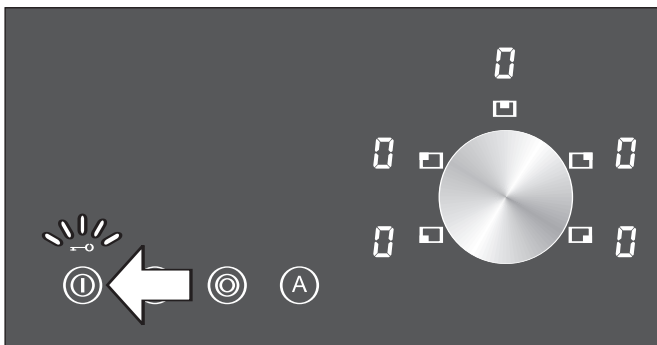
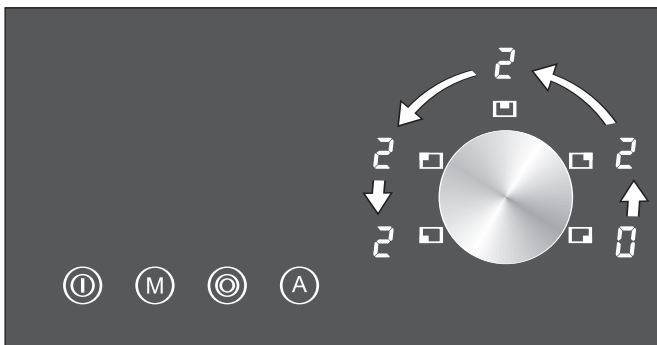

Operating the hob

To switch on, touch the ① main switch for more than 4 seconds. During this time, the → symbol lights up in the display. As soon as the display goes off, the hob is switched on.

Deactivating the child lock

You can deactivate the child lock again. Proceed in the same manner as for activating the child lock.

Single locking of the hob

You can lock the hob on a single occasion, if for example, small children are visiting:

The hob must be switched off. Touch the ① main switch for more than 4 seconds. The cooking zone displays go out. The → symbol flashes. The hob is locked.

Unlocking the hob

Touch the ① main switch for more than 4 seconds. The hob is switched on. The hob is unlocked.

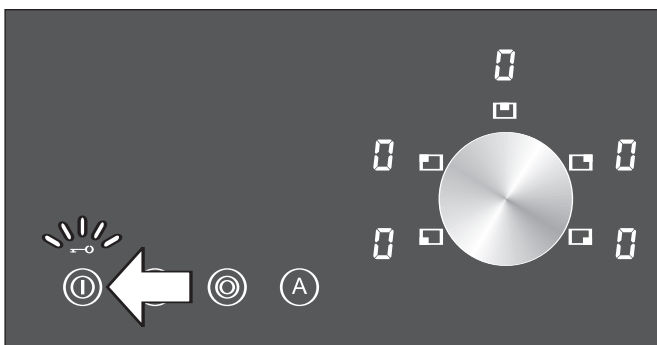

Additional functions

Switching off the confirmation tone

A short buzz confirms that a control panel has been touched. This buzzer can be switched off

- 1 Switch on the hob using the main switch.
- 2 Set all cooking zones to heat setting 3.
- 3 Switch off the cooking zones one after the other, beginning with the front right cooking zone.
- 4 Touch the main switch for at least 5 seconds, after which time a confirmation signal will sound.

To switch the entry confirmation on again, proceed in the same manner as for switching off.

Holiday safeguard

If a cooking zone is in constant use for a long time without the setting being changed, it will automatically switch off. The time after which the holiday safeguard is activated depends on the heat setting (1 to 10 hours).

The cooking zone is switched off, an *F* and an *B* flash alternately in the display.

The indicator goes out when you touch any control panel. Now you can reset the cooking zone.

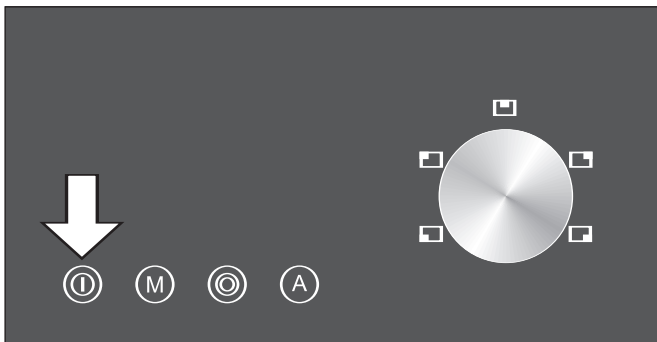
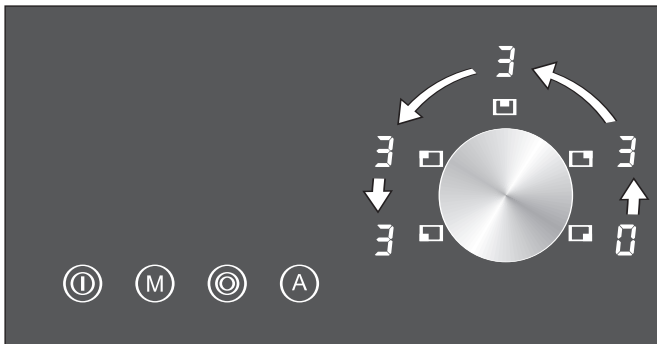

Memory cooking

Operating principle

Memory cooking is useful if you require several different heat settings in order to prepare a dish which you cook particularly often. The conditions must always be the same, e.g. the same saucepan, the same quantity and the same initial temperature of the dish.

You can store one memory event for each cooking zone with up to five heat and time settings, which you can recall at any time.

Storing the setting

You can store one memory event for each cooking zone. For each memory event you can record up to five settings. The maximum duration that can be recorded is 90 minutes.

The hob must be switched on. No cooking zone should be selected. The cooking zone for which the settings are to be recorded must be switched off.

- 1 Touch the **M** symbol. **rec** flashes in the display.
- 2 Select the required cooking zone and set the heat setting with the twist knob. Recording begins. The **rec** indicator lights up and **M** flashes next to the cooking zone display.
- 3 Now prepare the dish as required. The settings are recorded.
- 4 When your dish is ready, switch off the cooking zone. The cooking procedure is stored.

Notes

If you set more than 5 heat settings for your dish, **≡≡** flashes in the timer display and **≡** flashes in the cooking zone display alternately with the continuation cooking setting. The subsequent heat settings are not recorded. The timer indicator goes out when you touch any control panel. You can finish cooking the dish as you wish.

If you set more than 90 minutes, **99** flashes in the timer display and **≡** alternates with the ongoing cooking setting in the cooking zone display. Subsequent heat settings are not recorded. The indicators go out when you touch any control panel. You can finish cooking the dish as you wish.

If you store a memory event for a cooking zone with extension, the selected extension is stored for the whole memory event. Select the extension within 30 seconds after touching the **M** symbol. Later

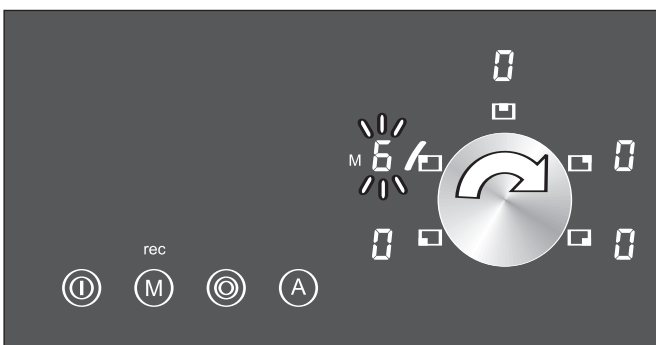
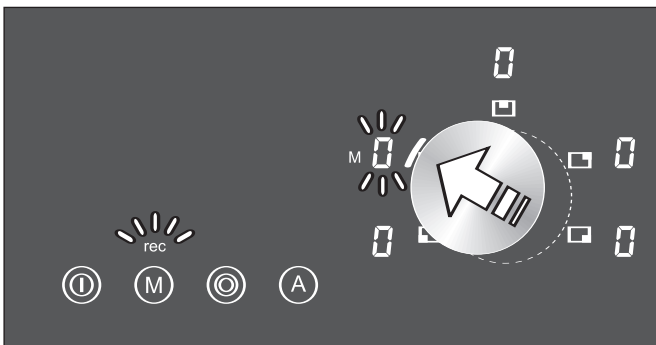
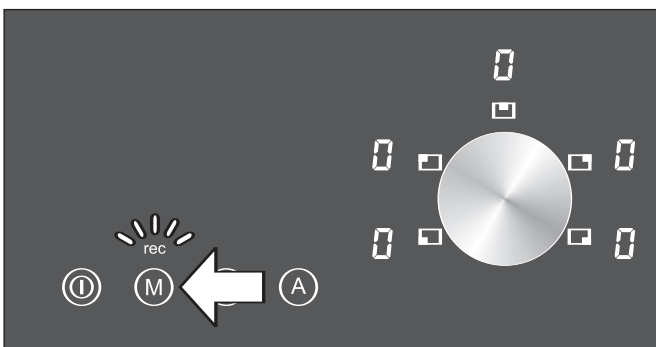

activation of the cooking zone extension will not be recorded.

If you store a memory event for the roasting zone, first select either of the right cooking zones. Activate the roasting zone extension within 30 seconds after selecting the cooking zone.

The automatic quick boil function cannot be activated for memory cooking.

The automatic switch off (holiday safeguard) can also be activated while using memory cooking.

Changing the setting

If you want to store a different memory event for a cooking zone, make a new recording. The old memory is erased.

Calling up the memory

If you want to cook a dish again for which the setting has been recorded, call up the memory.

The hob must be switched on. The cooking zone for which the memory function is to be activated must be switched off.

- 1 Select the required cooking zone with the twist knob.
- 2 Touch the **M** symbol to activate the memory.

The stored settings appear in the cooking zone display in quick succession. The cooking zone does not heat up yet. The **M** symbol next to the cooking zone display lights up. Each individual step appears in the display for 3 seconds. The respective cooking times appear in the timer display.

After all the steps have been displayed, the memory program starts. The cooking zone heats up. The current setting is displayed in the cooking zone display. The duration of the whole cooking event counts down in the timer display.



If you want to call up the memory event for the roasting zone, first select the cooking zone on the right that you used to store the memory event. The remaining right cooking zone must be switched off. Then touch the **M** symbol.

Displaying the memory

You can call up the remaining heat settings and the respective cooking times while the memory program is running.

- 1 Select the cooking zone with the twist knob.
- 2 Touch the ☹ symbol to display the current heat setting and duration. You can now call up all the remaining heat settings and the respective durations using the ☹ symbol.

Memory ends

When the memory program has finished, the cooking zone switches off. A signal sounds for 3 minutes.  flashes in the timer display. The **M** symbol flashes next to the cooking zone display.  lights up in the cooking zone display. Touch any control panel. The displays disappear and the signal stops.

Ending the memory prematurely



Select the cooking zone with the twist knob. The cooking zone display flashes. Change the heat setting. The memory operation is ended. The cooking zone switches off.

Several cooking zones in memory operation

If you want to use the memory function on several cooking zones at the same time, the shortest duration of the memory programs is displayed in the timer display.

If you would like to call up the duration of another memory program: Select the cooking zone with the twist knob. The current setting is displayed.

Cleaning and care

-  Do not clean the hob using high pressure cleaners or steam jets.
-  Caution, risk of burns! Before cleaning, wait until the residual heat display has gone out.
-  Caution, risk of injury! The blade of the included glass scraper is very sharp. Replace damaged blades immediately.

Cleaning the glass ceramic

Clean the hob after every use. This prevents food from being burnt into the hob surface.

Use the blade scraper to remove food residues and grease splashes. Only use the blade on the glass ceramic hob. Do not use the blade casing as it may scratch the glass ceramic.

Use a glass ceramic cleaner and kitchen towel or a soft, moist cloth to clean the surface when it is luke warm.

Wipe the surface with a moist cloth and rub dry with a soft cloth.

Do not apply the cleaner if the surface is still too hot. It can become stained.

Water marks can also be removed using lemon juice or vinegar.

The glass ceramic cleaner will coat the glass ceramic surface with a gleaming, dirt repellent film. This will help to preserve the attractive appearance of your hob over a long period of time and make it easier to clean as well.

Do not use scouring, abrasive or chemically aggressive cleaners (e.g. oven cleaner). Do not use cleaners which contain sand or chlorine. Do not use abrasive sponges or brushes.

Food with a high sugar content (e.g. boiled-over milk, jam) can damage the surface of your hob. Immediately remove such food using the glass scraper.

Iridescent discoloration can be caused by the use of unsuitable cleaning agents or abrasion from the bases of some pots. These do not interfere with the operation of the glass ceramic hob. Remove the discoloration with glass ceramic cleaner.

Always keep the control panels clean and dry. Food residues and spills can impair the function of the control panels.

Please refer to the enclosed brochure for further notes on cleaning.

Cleaning the stainless steel frame (only CE 491)

Use a soft cloth and light soapy liquid or a commercially available stainless steel cleaner to clean the hob frame. Only wipe in the direction of the brushed metal.

Do not use any aggressive or abrasive cleaners. Do not use the blade scraper, as it may scratch the hob frame.

Do not use lemon or vinegar to clean the hob frame. This could result in matt patches.

Cleaning the twist knob

Wipe the twist knob using lukewarm soapy water only. Do not use any aggressive or abrasive cleaners. The twist knob could be damaged if cleaned in a dishwasher or immersed in soapy water.

Useful hints

The temperature of the cooking zones is controlled by switching the heat on and off, this means that it is not always possible to see the red, glowing heat. If you select a low heat setting, the heat will switch off more often than at higher heat settings. Even at the highest setting the heat switches on and off.

There may be a gentle buzzing as the cooking zones heat up.

The heat may show differently on the individual cooking zones. Depending on the angle of vision, the heat may appear to spread beyond the marked boundary of the cooking zone. These are technical features and do not influence quality or function.

Maintenance

If the appliance does not function correctly, check the household fuses first. If the power supply is functioning correctly, please contact your dealer or the Gaggenau after-sales service.

Please quote the E number (product number) and the FD number (production number) of your appliance when contacting the after-sales service. The quality control slip bearing these numbers is included with this manual. This quality control slip should be kept, for guarantee reasons, together with your operating and assembly instructions.

Repairs may only be carried out by authorised technicians, in order to guarantee the safety of the appliance.



Caution! Incorrect repairs may result in serious injury to the user.

All poles of the appliance must be disconnected from the mains when being repaired (switch off the household fuse or the circuit breaker in the fuse box).

Non compliance with these recommendations results in the warranty coverage becoming invalid.

Trouble shooting

Not every malfunction can be ascribed to a defect of your cooker. If your appliance should not function properly, search for the fault in the list below. If you are not successful in remedying the fault with the aid of the list below, then contact your Gaggenau after-sales service.

The hob does not work

Check that the household fuses for the appliance are OK. Check if there has been a power cut.

The hob functions but does not heat up. A spot lights constantly in the timer display.

The hob is on show room mode after installation. Disconnect the hob from the power supply for at least 10 seconds. Reconnect the hob and within 3 minutes carry out the following procedure:

- 1 Hob must be switched off at main switch. Timer must be off.
- 2 Touch the symbol extension © and keep the finger pressed down. Within 3 seconds touch and release the main switch.
- 3 Remove your finger from the symbol extension. A signal will sound. The spot in the timer display goes off.

The hob has switched itself off

The main switch was touched accidentally. Switch the hob back on.

U400 display

The hob is connected incorrectly.

Disconnect the appliance from the mains using the household fuse or the circuit breaker in the fuse box. Call the installation technician.

E flashes in a cooking zone display

The control panel is very dirty, food has spilt over or there is an object on the control panel. Wipe the control panel thoroughly or remove the object. Touch the appropriate control panel. The flashing stops.

E flashes in all the cooking zone indicators and a signal sounds

The main switch was touched continuously for more than 5 seconds or there is an object on the main switch. Wipe the control panel thoroughly or remove the object. Switch the hob back on.

Er display and numbers

If an Er and numbers appear in the display, there is a fault with the electronics. Switch the hob off and on again using the household fuse or the circuit breaker in the fuse box. Call the after-sales service if the display appears again.

F2 display

The hob is too hot and has switched itself off. Remove the pans from the cooking zones. F2 disappears from the display when the indicator is acknowledged (by touching any control panel) and when the cooking zones have cooled sufficiently.

Wait a few minutes until the cooking zones have cooled down slightly. If F2 appears again after the cooking zones are switched back on, the hob is still too hot. Switch off the cooking zones and allow to cool further.

F4 display

The control panel is too hot and the hob has switched itself off. Check whether there is a hot pan on the control panel.

Remove the pan from the control panel. Wait a few minutes until the control panel has cooled down slightly. If F4 appears again after the cooking zones are switched back on, call the after-sales service.

FB display

A cooking zone has been in constant operation for too long. The holiday safeguard was activated. Switch off the cooking zone. It can be switched on again immediately.

Gaggenau Hausgeräte GmbH
Carl-Wery-Straße 34
D-81739 München
www.gaggenau.com

9000159809 EB 8604 en

GAGGENAU