

# EB 385

Built-in oven

---

## Table of contents

---

<b>Important safety information</b>	<b>3</b>
Causes of damage	4
<b>Environmental protection</b>	<b>5</b>
Environmental protection	5
Saving energy	5
<b>Getting to know the appliance</b>	<b>6</b>
Oven	6
Displays and controls	6
Operating modes	7
Cooling fan	7
<b>Your accessories</b>	<b>8</b>
Inserting accessories	8
Accessories	8
Special accessories	8
<b>Before using for the first time</b>	<b>9</b>
Setting the time	9
Heating up the oven	9
Cleaning accessories	9
<b>Operating the appliance</b>	<b>9</b>
Switching on	9
Switching off	9
Settings table	10
<b>Timer functions</b>	<b>11</b>
Cooking time	11
End of cooking time	11
Timer	12
Alarm clock function	12
Stopwatch	12
<b>Core temperature probe</b>	<b>13</b>
Inserting the core temperature probe in the food to be cooked	13
Setting the core temperature	14
Core temperature guidelines	15
<b>Rotisserie spit (special accessory)</b>	<b>16</b>
Fitting and securing a roast	16
Inserting the rotisserie spit	16
<b>Baking stone (special accessory)</b>	<b>16</b>
Using the baking stone	16
Cleaning the baking stone	16
<b>Child lock</b>	<b>17</b>
Activating the child lock	17
Deactivating the child lock	17

<b>Basic settings</b>	<b>17</b>
<b>Cleaning and maintenance</b>	<b>18</b>
Cleaning agents	18
Drying the cooking compartment	18
Replacing the oven lamp	18
Glass cover	18
<b>Trouble shooting</b>	<b>19</b>
<b>After-sales service</b>	<b>20</b>

Additional information on products, accessories, replacement parts and services can be found at [www.gaggenau.com](http://www.gaggenau.com) and in the online shop [www.gaggenau-eshop.com](http://www.gaggenau-eshop.com)

## **⚠ Important safety information**

Read these instructions carefully. Only then will you be able to operate your appliance safely and correctly. Retain the instruction manual and installation instructions for future use or for subsequent owners.

This appliance is only intended to be fully fitted in a kitchen. Observe the special installation instructions.

Check the appliance for damage after unpacking it. Do not connect the appliance if it has been damaged in transport.

Only a licensed professional may connect appliances without plugs. Damage caused by incorrect connection is not covered under warranty.

This appliance is intended for domestic use only. The appliance must only be used for the preparation of food and drink. The appliance must be supervised during operation. Only use this appliance indoors.

This appliance is intended for use up to a maximum height of 2000 metres above sea level.

This appliance may be used by children over the age of 8 years old and by persons with reduced physical, sensory or mental capabilities or by persons with a lack of experience or knowledge if they are supervised or are instructed by a person responsible for their safety how to use the appliance safely and have understood the associated hazards.

Children must not play with, on, or around the appliance. Children must not clean the appliance or carry out general maintenance unless they are at least 8 years old and are being supervised.

Keep children below the age of 8 years old at a safe distance from the appliance and power cable.

Always slide accessories into the cooking compartment correctly. See description of accessories in the instruction manual.

### **Risk of fire!**

- Combustible items stored in the cooking compartment may catch fire. Never store combustible items in the cooking compartment. Never open the appliance door if there is smoke inside. Switch off the appliance and unplug it from the mains or switch off the circuit breaker in the fuse box.
- A draught is created when the appliance door is opened. Greaseproof paper may come into contact with the heating element and catch fire. Do not place greaseproof paper loosely over accessories during preheating. Always weight down the greaseproof paper with a dish or a baking tin. Only cover the surface required with greaseproof paper. Greaseproof paper must not protrude over the accessories.

### **Risk of burns!**

- The appliance becomes very hot. Never touch the interior surfaces of the cooking compartment or the heating elements. Always allow the appliance to cool down. Keep children at a safe distance.
- Accessories and ovenware become very hot. Always use oven gloves to remove accessories or ovenware from the cooking compartment.
- Alcoholic vapours may catch fire in the hot cooking compartment. Never prepare food containing large quantities of drinks with a high alcohol content. Only use small quantities of drinks with a high alcohol content. Open the appliance door with care.

### **Risk of scalding!**

- The accessible parts become hot during operation. Never touch the hot parts. Keep children at a safe distance.
- When you open the appliance door, hot steam may escape. Open the appliance door with care. Keep children at a safe distance.

- Water in a hot cooking compartment may create hot steam. Never pour water into the hot cooking compartment.

### **Risk of injury!**

Scratched glass in the appliance door may develop into a crack. Do not use a glass scraper, sharp or abrasive cleaning aids or detergents.

### **Risk of electric shock!**

- Incorrect repairs are dangerous. Repairs may only be carried out and damaged power cables replaced by one of our trained after-sales technicians. If the appliance is defective, unplug the appliance from the mains or switch off the circuit breaker in the fuse box. Contact the after-sales service.
- The cable insulation on electrical appliances may melt when touching hot parts of the appliance. Never bring electrical appliance cables into contact with hot parts of the appliance.
- Do not use any high-pressure cleaners or steam cleaners, which can result in an electric shock.
- When replacing the cooking compartment bulb, the bulb socket contacts are live. Before replacing the bulb, unplug the appliance from the mains or switch off the circuit breaker in the fuse box.
- A defective appliance may cause electric shock. Never switch on a defective appliance. Unplug the appliance from the mains or switch off the circuit breaker in the fuse box. Contact the after-sales service.
- The insulation of an incompatible meat probe may be damaged. Only use the meat probe which is recommended for this appliance.

### **Risk of burns!**

The appliance will become very hot on the outside during the cleaning function. Never touch the appliance door. Allow the appliance to cool down. Keep children at a safe distance.

## **Causes of damage**

### **Caution!**

- Accessories, foil, greaseproof paper or ovenware on the cooking compartment floor: do not place accessories on the cooking compartment floor. Do not cover the cooking compartment floor with any sort of foil or greaseproof paper. Do not place ovenware on the cooking compartment floor if a temperature of over 50 °C has been set. This will cause heat to accumulate. The baking and roasting times will no longer be correct and the enamel will be damaged.
- Water in a hot cooking compartment: do not pour water into the cooking compartment when it is hot. This will cause steam. The temperature change can cause damage to the enamel.
- Moist food: do not store moist food in the cooking compartment when it is closed for prolonged periods. This will damage the enamel.
- Fruit juice: when baking particularly juicy fruit pies, do not pack the baking tray too generously. Fruit juice dripping from the baking tray leaves stains that cannot be removed. If possible, use the deeper universal pan.
- Cooling with the appliance door open: only allow the cooking compartment to cool when it is closed. Even if the appliance door is only open a little, front panels of adjacent units could be damaged over time.
- Very dirty door seal: If the door seal is very dirty, the appliance door will no longer close properly when the appliance is in use. The fronts of adjacent units could be damaged. Always keep the door seal clean.
- Appliance door as a seat, shelf or worktop: Do not sit on the appliance door, or place or hang anything on it. Do not place any cookware or accessories on the appliance door.
- Inserting accessories: depending on the appliance model, accessories can scratch the door panel when closing the appliance door. Always insert the accessories into the cooking compartment as far as they will go.
- Carrying the appliance: do not carry or hold the appliance by the door handle. The door handle cannot support the weight of the appliance and could break.

---

## Environmental protection

---

Unpack the appliance and dispose of the packaging in an environmentally-responsible manner.

## Environmental protection



This appliance is labelled in accordance with the European Directive 2012/19/EU concerning used electrical and electronic appliances (WEEE – waste electrical and electronic equipment). The guideline determines the framework for the return and recycling of used appliances as applicable.

## Saving energy

- Only preheat the oven if this is specified in the recipe or in the operating instruction tables.
- Use dark, black lacquered or enamelled baking tins. They absorb the heat particularly well.
- Open the oven door as infrequently as possible while you are cooking, baking or roasting.
- It is best to bake several cakes one after the other. The oven is still warm. This reduces the baking time for the second cake. You can also place two loaf tins next to each other.
- For longer cooking times, you can switch the oven off 10 minutes before the end of the cooking time and use the residual heat to finish cooking.

# Getting to know the appliance

## Oven

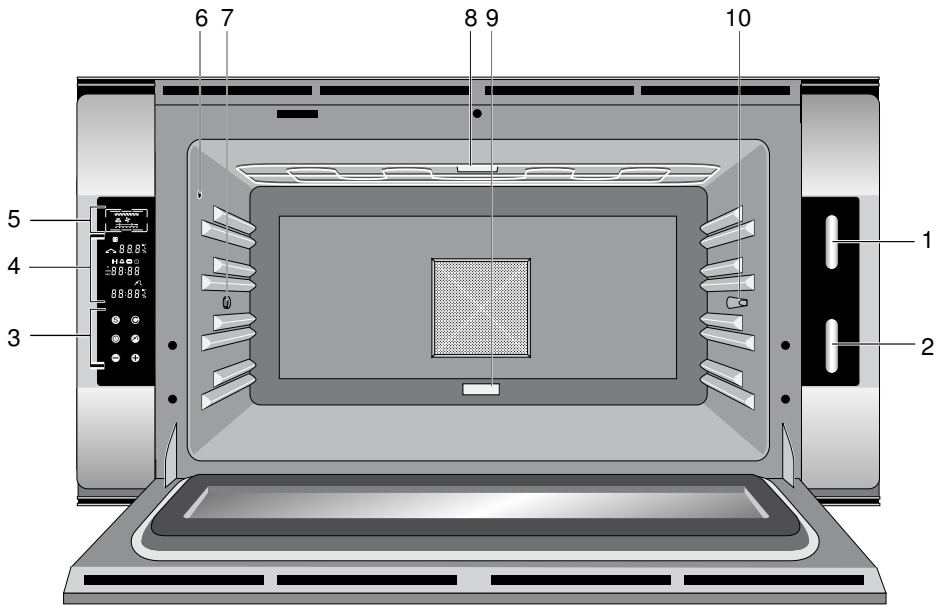

1	Temperature selector
2	Mode selector
3	Function keys
4	Display functions
5	Display mode
6	Socket for core temperature probe
7	Holder for rotisserie spit
8	Oven lighting
9	Socket for baking stone
10	Locking element for rotisserie spit

Key	Function
S	Start/status
C	ON/OFF Rotisserie spit
🕒	Timer functions
🍖	Core temperature probe
- +	Increase value/reduce value











Symbol	Meaning
🔒	Child lock
🔥	Warming up
⏸	Duration, end
🔔	Timer/alarm time
🕒	Cooking time
🕒	Clock
🍖	Core temperature probe
88.8°C	Set temperature/power
h min sec 00:00	Time display
00:00°C	Current temperature/power

## Displays and controls



## Operating modes

The following operating modes are at your disposal. To select the operating mode, turn the mode selector until the required function appears in the mode display.

Display	Temperature	Mode	Use
	50 - 300° C	Hot air	Baking, roasting, thawing, drying, desiccating, sterilising
	50 - 300° C	Hot air + bottom heat	Baking, roasting
	50 - 300° C	Grilling + hot air	Temperature controlled grilling with hot air, intensive grilling with hot air
	50 - 300° C	Grilling*	Power-controlled grilling
	50 - 300° C	Economy grilling*	Power-controlled grilling with the left grill
	50 - 300° C	Bottom heat	Crisping up or cooking and keeping warm from below
	50 - 300° C	Bottom heat + 1/3 top heat	Crisping up or cooking and keeping warm from below and, to some extent, from above
	50 - 300° C	Top heat + bottom heat	Baking and roasting
	50 - 300° C	Top heat + 1/3 bottom heat	Crisping up or cooking and keeping warm from above and, to some extent, from below
	50 - 300° C	Top heat	Crisping up or cooking and keeping warm
	50 - 300° C	Baking stone (with special accessory only)	Baking stone for baking bread and pizza
*50% → 150° C    80% → 240° C 60% → 180° C    90% → 270° C 70% → 210° C    100% → 300° C			

## Cooling fan

The cooling fan switches on and off as required. The hot air escapes above the door. Caution: do not cover the ventilation slots. Otherwise the oven will overheat.

So that the cooking compartment cools down more quickly after operation, the cooling fan continues to run for a certain period afterwards.

---

## Your accessories

---

The accessories supplied with your appliance are suitable for making many dishes. Ensure that you always insert the accessories into the cooking compartment the right way round.

Only use the accessories as specified. The manufacturer accepts no liability if these accessories are used incorrectly.

### Inserting accessories

The gridiron features a latching function. The latching function prevents tilting of the gridiron when pulling it out. You must insert the gridiron in the cooking interior correctly so that tilt protection will work.

When pushing in the gridiron, make sure that the latching lugs at the side point up.

### Accessories

As standard, your appliance comes with the following accessories:

2 baking trays

1 grill tray with grille

1 gridiron

1 plug-in core temperature probe

## Special accessories

You can order the following special accessories from your specialist dealer:

BS 020 002	Pizza paddle, set of 2
DS 070 062	Rotisserie spit
GP 032 062	Grill tray, enamelled 39 mm deep
GR 030 062	Gridiron, chrome-plated. Angled, without opening
GR 035 062	Gridiron, chrome-plated With opening and feet
KB 032 062	Baking tray, enamelled 18 mm deep
KB 036 062	Baking tray, enamelled 20 mm deep
PS 075 001	Baking stone Including heating element, baking stone support and pizza paddle



---

## Before using for the first time

---

Here, you will find out what you have to do before preparing food with your oven for the first time. Read the Safety information section beforehand.

### Setting the time

When a new appliance is connected, or after a prolonged power failure, the time **00:00** appears in the time display.

Proceed as follows to set the time:

- 1 Press the **⌚** key four times. The **⌚** symbol flashes in the display.
- 2 Set the time with the **+** and **-** keys.
- 3 Press the **S** key. The time display lights up in the display.

You can also set the time anytime later. Proceed in the same way to do this.

**Note:** when the oven is switched off, the time display is hidden to ensure compliance with the EU regulation on electricity consumption in the standby mode. Refer to the section entitled "Basic settings" to find out how to permanently display the time anyway.

### Heating up the oven

Make sure there are no packaging remainders left in the interior.

Heat up the empty, closed oven to dispel the 'new' smell. An hour of hot air at 200°C is ideal.

Then allow the oven to cool down and wipe the surfaces with a moist cloth.

### Cleaning accessories

Before using the accessories for the first time, clean them thoroughly using hot detergent solution and a soft cloth.

**Note:** do not clean the baking stone with water and detergent. Cracks can appear in the material if a moist baking stone is heated up. If the baking stone should ever become moist, it must dry out completely before the next time it is heated up. This can take several days.

---

## Operating the appliance

---

### Switching on

- 1 Set the temperature selector to the required value. The temperature and the mode are displayed.
- 2 Set the required mode with the mode selector.

The warming up symbol **↻** appears in the display until the set temperature has been reached. It appears again during post-heating.

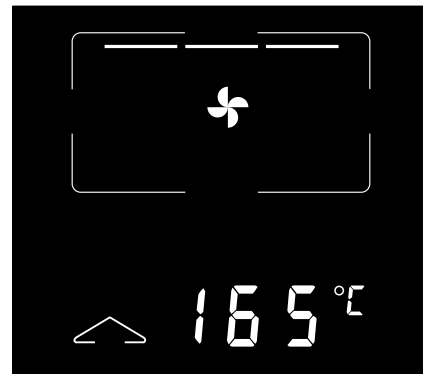

Displaying the current temperature:

You can query the current temperature in the cooking interior at any time. To do this, press the **S** key. The current temperature is shown briefly in the bottom part of the display.

**Note:** during continuous operation of the oven, system-related temperature fluctuations of up to 5° C above or below the set temperature are within the normal range.

### Switching off

To switch off the oven, set the temperature selector to 0. The oven lighting goes out and the oven is in stand-by mode.

**Note:** The clock display goes out in stand-by mode. Press any button to display the time again. The "Basic settings" section provides information on how to display the time permanently.

#### Caution!

To prevent the enamel from being damaged, do not leave food to cool down or be stored in the appliance. If condensation has formed in the cooking compartment, heat up the appliance for 5 minutes with hot air at 50 °C and then open the door so that the moisture can evaporate.

## Settings table

The values given are for a preheated appliance. The values must be looked upon as a guideline. The heat required depends on the type and condition of the food.

Dishes	Hot air (temp. °C)	top and bot- tom heat (temp. °C)	Level	Cooking time (approx. h:min) Recommended (core temperature)	Own
<b>Cake/biscuits</b>					
Swiss roll	180	180-190	2nd from below	00:19-00:20	
Sponge cake base	165	165-175	2nd from below	00:30-00:35	
Yeast cake	165	165-175	2nd from below	00:30-00:35	
Cheesecake (high)	165	165-175	2nd from below	01:20-01:35	
Cheesecake slice	165	165-175	2nd from below	01:00-01:10	
Small cakes and biscuits	165		1st/2nd/3rd from below	00:15-00:20	
		165-175	2nd from below	00:15-00:20	
Ring cake (yeast dough)	165	165-175	1st from below	00:45-00:50	
Fruit flan	165	165-175	2nd from below	00:45-00:50	
Choux pastry (cream puffs)	180	180-190	2nd from below	00:25-00:30	
mixed cake	165	165-175	2nd from below	00:55-01:00	
<b>Meat</b>					
Pork roast (1.5 kg)	220/180*		2nd from below	01:30 (80°C)	
Roast beef rare	275/200*		2nd from below	00:30-00:35 (40-50°C)	
Medium-rare	275/200*		2nd from below	00:45-00:50 (55-65°C)	
Well-done	275/200*		2nd from below	01:00-01:10 (65-75°C)	
Roast veal	175		2nd from below	01:10-01:20	
Lamb	220/180*		2nd from below	01:10 (75°C)	
<b>Venison</b>					
Leg of venison	175-200		2nd from below	01:30-01:40 (80-85°C)	
Wild boar	175-200		2nd from below	01:30-01:40 (80-85°C)	
<b>Poultry</b>					
Poultry	180		2nd from below	01:00 (90°C)	
<b>Fish</b>					
Fish fillet	200-225		2nd from below	00:30-00:50	
Fish (1.5 - 2 kg)	200		2nd from below	00:30-00:50	
* You are advised to reduce the temperature to the adjacent value after about 20 minutes.					

## Timer functions

You can set the following timer functions:

- Cooking time
- Cooking time end
- Timer
- Stopwatch
- Alarm clock function

Use the operator control keys to operate the timer functions. Visual and audible signals assist you with operation:

Short deep tone	Selection is being made
Short high tone	Input completed
Deep tone sequence	Programmed value reached, awaiting confirmation
Flashing display symbol	Awaiting input or confirmation
Dashes in the display	No value programmed

**Note:** when you press the  key, set times are displayed for 10 seconds.

### Correcting an input:

Press the  key. Within 10 seconds, correct the time value with the **+** and **-** keys. Confirm input with the **S** key. To clear an input, press the **+** and **-** keys at the same time.



## Cooking time

If you set a cooking time for your meal, the appliance switches off heating automatically after this time has elapsed.



You can set a cooking time from 1 minute to 23 hours 59 minutes.

Place your meal in the oven and set the temperature and mode you require with the temperature and mode selectors.



Programming the cooking time:

- 1 Press the  key once. The  and  symbols flash. The time display shows **--:--** or the current duration.



- 2 Set the required duration with the aid of the **+** and **-** keys.
- 3 Press the start key **S**. The  symbol goes off and the  lights up continuously.

After expiry of the duration:

The  flashes. An audible signal is sounded. The appliance ends heating. Press any key.  goes off, the signal tone goes off and heating is started again. Now set the temperature control to 0° C.

### Correcting an input:

Press the  key. Within 10 seconds, correct the time value with the **+** and **-** keys. Confirm input with the **S** key. To clear an input, press the **+** and **-** keys at the same time.



## End of cooking time

With this function you can move the end of the set cooking time to a later point in time.

To do this, enter the cooking time and program the required time for the end of the cooking time. The electronic circuitry calculated the corresponding starting time and starts cooking automatically.

**Note:** note that easily perishable foodstuffs must not be left in the oven for too long.

Proceed as follows:

- 1 Set a cooking time (see section entitled "Cooking time")
- 2 Press the  key twice. The  and  symbols flash. The time display shows **--:--** or the current duration.

- 3 Set the required time with the aid of the + and – keys.
- 4 Press the start key S. The | symbol goes off and the □ lights up continuously.

After expiry of the duration:

The □ flashes. An audible signal is sounded. The appliance ends heating. Press any key. The □ symbol goes off, the signal tone goes off and heating is started again. Now set the temperature control to 0° C.

**Note:** you can even program the switch-off time if you have not set a cooking time. Simply begin at point 2.

## Timer

You can use the timer to program a period of time, e.g. as an egg timer. You can enter values between 00:01 seconds and 23:50 hours.

- 1 Press the + key. The →| and 🔔 symbols flash. The time display shows --:-- or the current duration.

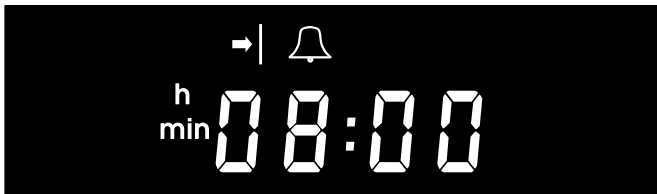

- 2 Set the required duration with + and –.
- 3 Press the S key. The 🔔 symbol and the elapsing timer are shown in the display. The timer starts, even without pressing the S key, if you do not enter anything for 5 seconds.

After expiry of the duration:

the 🔔 flashes. An audible signal is sounded. Press any key to end the timer.

**Note:** while the set timer is running, you can view the time of the day by pressing the S key.

## Alarm clock function

A signal tone can be triggered at any time of the day. The alarm clock function is independent of the other appliance functions.

**Note:** the alarm clock function does not switch off your appliance.

- 1 Press the ⌚ key three times. The →| and 🔔 symbols flash. The time display shows --:-- or the current duration.

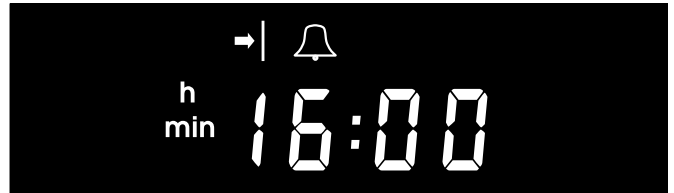

- 2 Set the required time with the aid of the + and – keys.
- 3 Press the start key S. The →| symbol goes off and the 🔔 lights up continuously.

After expiry of the duration:

The 🔔 symbol flashes. An audible signal is sounded. Press any key. 🔔 goes off and the signal tone is ended.

## Stopwatch

You can use the stopwatch to monitor the cooking time of dishes without programming automatic deactivation, for example.

The time is displayed beginning at 00:00 and extending up to a maximum of 12 hours.

### Switching the stopwatch on and off:

You start or switch off the stopwatch by pressing the – key.

## Core temperature probe

### **⚠ Risk of electric shock!**

The insulation of an incompatible meat probe may be damaged. Only use the meat probe which is recommended for this appliance.

### **⚠ Risk of burns!**







The cooking interior and the core temperature probe become very hot. Use oven mitts to plug and unplug the core temperature probe.

The core temperature probe enables exact cooking to the spot. It measures the temperature between 30 °C and 99 °C inside the food cooked.

Use the included core temperature probe only. If you need a replacement, you can purchase one from our after-sales service (order No. 156 838, also available online in the eShop).

The core temperature probe can be damaged at temperatures above 250 °C. Therefore, only ever use it in your electric oven (max. 230 °C).

Suitable heating modes:

-  Hot air
-  Hot air + bottom heat
-  Bottom heat
-  Bottom heat + 1/3 Top heat
-  Top heat + bottom heat
-  Top heat + 1/3 Bottom heat
-  Top heat

The set cooking interior temperature must be at least 10 °C higher than the set core temperature.

Always remove the core temperature probe from the cooking interior after use. Never store it in the cooking interior.

After every use, clean the core temperature probe with a moist cloth. Do not wash it in a dishwasher!

### **Caution!**

Do not use the temperature probe in combination with the rotisserie spit.

## Inserting the core temperature probe in the food to be cooked

Insert the core temperature probe in the food to be cooked before you place it in the cooking interior.

Insert the metal tip at the thickest point in the food to be cooked. Make sure that the end of the tip is approximately in the centre. It must not be placed in the fat and must not touch any cookware or bones.

If there are several pieces, insert the core temperature probe in the middle of the thickest piece.

Insert the core temperature probe completely, if possible.

In the case of poultry, make sure that the tip of the core temperature probe is not in the cavity in the centre, but in the meat between the belly and upper leg.

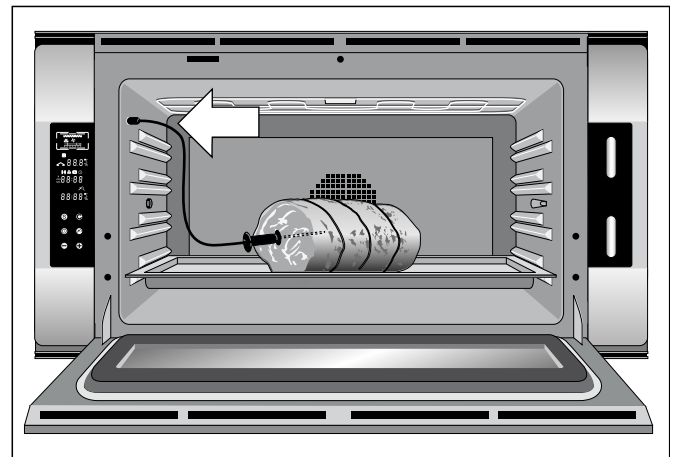



Place the food to be cooked in the middle of the gridiron.

## Setting the core temperature

### Risk of burns!

If you only insert the core temperature probe after the appliance was already in operation, the cooking interior surface and accessories can be very hot. Use oven cloths!

- 1 Insert the core temperature probe in the socket on the top right of the cooking interior and close the appliance door.  
Do not jam the core temperature probe's cable!  appear in the display. The core temperature appears in the core temperature display. The core temperature display flashes at a core temperature below 30° C and above 99° C.
- 2 Set the heating mode and the cooking temperature with the rotary selectors.
- 3 Press the  key.



The  symbol flashes. The suggested temperature of 60° C or a higher measured core temperature appears in the core temperature display.

- 4 Set the required core temperature (30 - 99° C) with the + and - keys.
- 5 Press the S key to start the cooking mode.  
Once the food you are cooking has reached a core temperature of 30 °C, the current core temperature appears in the display under the  symbol.  
You can change the set core temperature at any time.

Once the set core temperature is reached, a signal sounds and the  symbol flashes. The cooking mode is ended automatically.

Heating is started again by pressing any key.

- 6 Turn the temperature selector to 0° to end heating.

### Risk of burns!

The core temperature probe and cooking interior are hot. Allow the cooking interior to cool down before you pull out the core temperature probe or use oven cloths.

**Note:** if you leave the cooked food in the cooking interior for some time after the cooking mode has ended, the core temperature will rise slightly due to the residual heat in the cooking interior.

## labelling cooking with a core temperature

Use an oven cloth to pull the core temperature probe out of the socket. The appliance continues to heat in the normal cooking mode.

## Core temperature guidelines

Use chilled food only, not frozen food. The details given in the table are guidelines. Results depend on the quality and composition of the food.

For hygiene reasons, critical foodstuffs such as fish and game should reach a core temperature of 62 – 70 °C; for poultry and minced meat this should be as high as 80 – 85 °C.

Food	Core temperature guideline
<b>Beef</b>	
Sirloin, tenderloin, entrecôte	
very rare	45 – 47 °C
rare	50 – 52 °C
medium	58 – 60 °C
well-done	70 – 75 °C
Joint of beef	80 – 85 °C
<b>Pork</b>	
Joint of pork	72 – 80 °C
Loin of pork	
medium	65 – 70 °C
well-done	75 °C
Meat loaf	85 °C
Fillet of pork	65 – 70 °C
<b>Veal</b>	
Joint of veal, well-done	75 – 80 °C
Breast of veal, stuffed	75 – 80 °C
Saddle of veal	
medium	58 – 60 °C
well-done	65 – 70 °C
Fillet of veal	
rare	50 – 52 °C
medium	58 – 60 °C
well-done	70 – 75 °C
<b>Game</b>	
Saddle of venison	60 – 70 °C
Leg of roe venison	70 – 75 °C
Venison loin steaks	65 – 70 °C
Saddle of hare or rabbit	65 – 70 °C

Food	Core temperature guideline
<b>Poultry</b>	
Chicken	85 °C
Guinea fowl	75 – 80 °C
Goose, turkey, duck	80 – 85 °C
Duck breast	
medium	55 – 60 °C
well-done	70 – 80 °C
Ostrich steak	60 – 65 °C
<b>Lamb</b>	
Leg of lamb	
medium	60 – 65 °C
well-done	70 – 80 °C
Saddle of lamb	
medium	55 – 60 °C
well-done	65 – 75 °C
<b>Mutton</b>	
Leg of mutton	
medium	70 – 75 °C
well-done	80 – 85 °C
Saddle of mutton	
medium	70 – 75 °C
well-done	80 °C
<b>Fish</b>	
Fillet	62 – 65 °C
Whole	65 °C
Terrine	62 – 65 °C
<b>Miscellaneous</b>	
Bread	90 °C
Paté	72 – 75 °C
Terrine	60 – 70 °C
Foie gras	45 °C

## Rotisserie spit (special accessory)

You can use the "rotisserie spit" function with all operating modes.

### Caution!

Do not use the temperature probe in combination with the rotisserie spit.

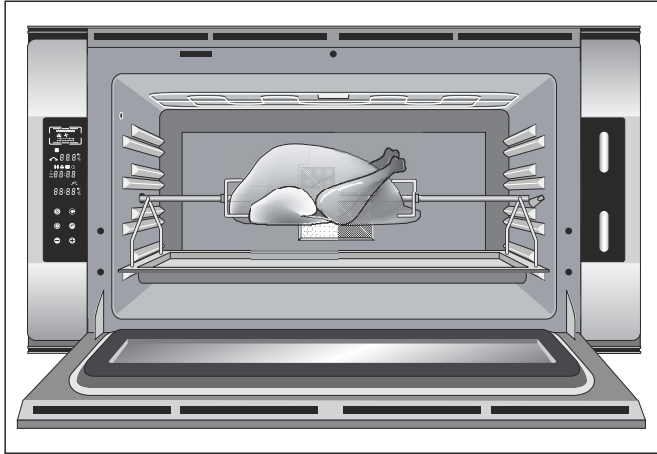

## Fitting and securing a roast

As far as possible, place the roast in the centre of the rotisserie spit.

Fasten the roast at both ends with the retaining clips.

You can also tie down the roast with kitchen thread. In the case of poultry, tie the wing ends under the back and the legs on the rump. Then, they will not get too dark. Pierce the skin under the wings so the fat can drain off.

Choose the oven temperature according to the data in the table. If the temperature is too high, the meat or poultry becomes too dark on the outside. It stays largely raw on the inside.

## Inserting the rotisserie spit

- 1 Insert the left and right support brackets in the holes on the grill pan.
- 2 Place the rotisserie spit on the grill frame and push it into the cooking interior.
- 3 Insert and hook the right side of the rotisserie spit into the locking element in the cooking interior.
- 4 Turn the drive on and off with the **C** key. The  symbol appears in the mode display when the rotisserie spit is activated.

## Baking stone (special accessory)

With the baking stone you achieve baking results that are comparable to those of a solid stone oven.

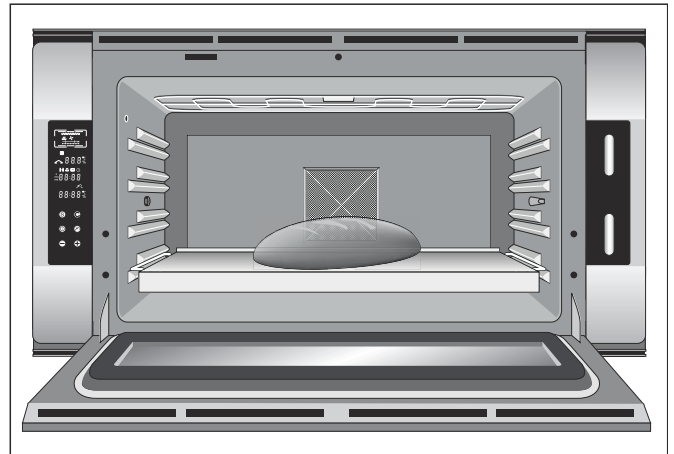

## Using the baking stone

- 1 Plug the heating element into the baking stone socket on the rear wall of the oven.
- 2 Insert the oven rack with the baking stone in the oven in the first level from below.  
**Note:** use the included wooden paddle to push in your items for baking.
- 3 Set the mode selector to the baking stone function , and set the temperature selector to the required temperature.

## Cleaning the baking stone

Use a soft brush to remove soiling and dough remainders.

### Notes

- Do not clean the baking stone with water and detergent.
- Lasting stains can remain on the baking stone despite cleaning. These do not have a detrimental effect on the taste of baked items, though.



---

## Child lock

---

The child lock prevents children from inadvertently switching on the appliance.

### Activating the child lock

Requirement: temperature selector is not set to 0.

- 1 Keep the **S** key pressed.
- 2 Switch off the oven with the temperature selector. The child lock is active and the  symbol flashes.

The selector switches can now be operated without triggering a heating cycle.

### Deactivating the child lock

- 1 Hold down the **S** key.
- 2 Switch on the oven with the temperature selector. The  symbol in the display goes off.

The child lock has been cancelled. You can once again switch on the appliance in the usual manner.

---

## Basic settings

---

You can adapt the following basic settings:

- Temperature display: °C/°F
- Time display: 12h (am/pm)/24h
- Time display on standby: ON/OFF

**Note:** when the time display is activated, the electricity consumed by the appliance exceeds the electricity consumption in the standby mode that is legally prescribed in the EU.

### How to operate the options menu:

- 1 Set the temperature and mode selector to 0.
- 2 Press the **S** and keep it pressed.
- 3 Turn the mode selector to the right.
- 4 Release the **S** key.
- 5 You can now select the various functions by turning the mode selector:
  - Position 1: temperature display °C/°F
  - Position 2: time display 12h/24h
  - Position 3: time display ON/OFF
- 6 Set the required values with **+** and **-**.
- 7 Press the **S** key to confirm.

To quit the options menu, set the mode selector to 0 or turn the temperature selector to any position.

## Cleaning and maintenance

### Risk of burns!

The appliance becomes very hot. Never touch the interior surfaces of the cooking compartment or the heating elements. Always allow the appliance to cool down. Keep children at a safe distance.

### Risk of electric shock!

Do not use any high-pressure cleaners or steam cleaners, which can result in an electric shock.

## Cleaning agents

Pay attention to the information in the table to ensure that the various surfaces are not damaged by incorrect cleaning agents. Do not use any

- sharp or abrasive cleaning agents
- highly alcoholic cleaning agents
- hard abrasive pads or cleaning sponges
- high-pressure or steam cleaners

Thoroughly rinse out new sponge cloths before use.

Area	Cleaning agent
Oven front	Hot soapy water: Clean with a dish cloth and dry with a soft cloth. Do not use any glass cleaner or scrapers.
Stainless steel	Hot soapy water: Clean with a dish cloth and dry with a soft cloth. Remove scale, grease, starch and protein stains immediately. Corrosion can form under such stains.  Stainless care products that are suitable for warm surfaces are obtainable from after-sales service or trade dealers. Apply a wafer-thin coat of care product with a soft cloth.
Door panes	Glass cleaner: Clean with a soft cloth. Do not use any glass scrapers.
Cooking interior	Hot soapy water: Clean with a dish cloth.  Use oven cleaner for extreme soiling. Use in the cold cooking interior only.
Glass cover of the oven lamp	Hot soapy water: Clean with a dish cloth.
Seal Do not remove!	Hot soapy water: Clean with a dish cloth. Do not scour.
Racks	Hot soapy water: Soak and clean with a dish cloth or a brush.

Area	Cleaning agent
Telescopic pull-out racks	Hot soapy water: Clean with a dish cloth or a brush. Do not soak or clean in a dishwasher.
Accessories	Hot soapy water: Soak and clean with a dish cloth or a brush.

## Drying the cooking compartment

To prevent the enamel from being damaged, carefully dry the cooking compartment after cleaning. After cleaning, leave the appliance door ajar in the stop position (approx. 30°) for approx. 1 hour to allow the enamel surfaces in the cooking compartment to dry thoroughly.

## Replacing the oven lamp

The lamp belonging to the oven lighting must be replaced if it has failed. You can obtain replacement lamps (article number 157 312) from Gaggenau after-sales service or from trade dealers. Use these lamps only.

### Risk of electric shock !

Disconnect the appliance from the power supply. Switch off the circuit breaker or remove the fuse from the household fuse box.

### Risk of burns!

The appliance becomes very hot. Never touch the interior surfaces of the cooking compartment or the heating elements. Always allow the appliance to cool down. Keep children at a safe distance.

Proceed as follows:

- 1 Undo the two screws with a Phillips screwdriver.
- 2 Remove the frame with the window pointing down.
- 3 You can tilt the lamp down and remove it by pressing on the contact spring.

Proceed in reverse order to insert the new lamp.

## Glass cover

You must replace a damaged glass cover. Suitable glass covers may be obtained from the after-sales service. Please specify the E number and FD number of your appliance.

---

## Trouble shooting

---

Malfunctions often have simple explanations. Please read the following notes before calling the after-sales service.

### Risk of electric shock!

Incorrect repairs are dangerous. Repairs may only be carried out by one of our trained after-sales engineers. If the appliance is faulty, unplug the mains plug or switch off the fuse in the fuse box. Contact the after-sales service.

Disruption	Possible cause	Solution
Appliance not working, no display	Plug not inserted	Connect the appliance to the electricity mains
	Power failure	Check whether other kitchen appliances are working
	Fuse defective	Check in the fuse box whether the fuse for the appliance is in working order
	Operating error	Switch off the fuse for the appliance in the fuse box and switch it on again after about 60 seconds
Appliance cannot be started	Appliance door is not quite closed	Close appliance door
Display of current temperature shows - - - - Continuous signal tone	Power supply was interrupted	Move the temperature selector to the 0 position and adjust the oven again.
Appliance switches off on its own.	Safety shut-off: the appliance has not been operated for longer than 12 hours	Switch off the appliance and set it again.
Oven lighting is on, the  symbol is lit and the appliance is not heating.	Your appliance is in the demo mode	<ol style="list-style-type: none"><li>1 Disconnect the appliance from the mains for a few seconds (switch off the fuse)</li><li>2 Switch on the fuse again, keep the <b>+</b> key pressed and set the temperature switch to any position (not light!).</li></ol>
No time display when the appliance is switched off	Your appliance is in the energy-saving standby mode	Changing the basic setting for the time display: See section entitled "Basic settings".

---

## After-sales service

---

In the event of repairs please contact our after-sales service. We are committed to find the best solution also in order to avoid an unnecessary call-out.

Please quote the E number (product number) and the FD number (production number) of your appliance when contacting the after-sales service. The rating plate bearing these numbers can be found on the front side when you open the appliance door.

For future reference you can note the data of your appliance and the telephone number of our after-sales service below.

---

E-Nr.	FD-Nr.
<hr/> <b>After-sales service</b> 	

---

Please note that calling out an after-sales service technician is not free of charge, even within the warranty period, should the problem result from an operating error.

Please find the contact data of all countries in the enclosed customer service list.

### To book an engineer visit and product advice

- GB** 0844 89289988  
Calls from a BT landline will be charged at up to 3 pence per minute. A call set-up fee of up to 6 pence may apply.
- IE** 01450 2655  
0.03 € per minute at peak.  
Off peak 0.0088 € per minute.
- AU** 1300 727 421
- NZ** 09 477 0492

Trust the expertise of the manufacturer, and rest assured that the repair will be carried out by trained service technicians using original spare parts for your domestic appliance.







**Gaggenau Hausgeräte GmbH**  
Carl-Wery-Straße 34  
D-81739 München  
[www.gaggenau.com](http://www.gaggenau.com)

**GAGGENAU**



9000753336 en (950610)