

VG425311SG

Gas hob (HK Town Gas)

煤氣爐 (香港煤氣)

Attention! According to the Gas Safety Ordinance of Hong Kong, any gas installation works including installation of appliances and connection tubing, must be undertaken by registered gas installers who are registered for that appropriate classes and be employed by registered gas contractor.

注意！根據香港氣體安全條例，任何氣體裝置工程，包括爐具和接駁喉管的安裝，必須由註冊氣體裝置技工執行，而該技工已於相關的氣體工程類別註冊和受聘於註冊氣體工程承辦商。

Table of contents

Additional information on products, accessories, replacement parts and services can be found at www.gaggenau.com and in the online shop www.gaggenau.com/zz/store

Intended use	3
Important safety information	4-5
Causes of damage	6
Environmental protection	6
Saving energy	6
Environmentally-friendly disposal	6
Familiarising yourself with your appliance	7-8
Gas hob	7
Control knob	7
Visual signals of the luminous disc	7
Installation accessories	8
Special accessories	8
Individual parts of the wok burner	8
Operating the appliance	9
Switching on	9
Simmer setting	9
Electronic flame monitoring and automatic re-ignition	9
Switching off	9
Residual heat indicator	9
Safety shut-off	9
Table of settings and tips	10
Tips for cooking and roasting	10
Information and tips regarding cookware	11
Suitable cooking vessels	11
Precautions for use	11
Cleaning and maintenance	12
Cleaning the appliance	12
Burnt-on dirt	12
Burner discolouration	12
Trouble shooting	13
After-sales service	14
E number and FD number	14

Intended use

Read these instructions carefully. Only then will you be able to operate your appliance safely and correctly. Retain the instruction manual and installation instructions for future use or for subsequent owners.

This appliance is only intended to be fully fitted in a kitchen. Observe the special installation instructions.

This appliance must be installed according to the installation instructions included.

Check the appliance for damage after unpacking it. Do not connect the appliance if it has been damaged in transport.

According to the Gas Safety Ordinance of Hong Kong, any gas installation works including installation of appliances and connection tubing, must be undertaken by registered gas installers who are registered for that appropriate classes and be employed by registered gas contractor.

Only allow a registered gas installer to connect the appliance. Damage caused by incorrect connection is not covered under warranty.

This appliance is intended for domestic use and the household environment only. This appliance must only be used to prepare food and drinks and must never be used as a heater. Do not leave the appliance unattended during operation. Only use the appliance indoors.

Do not install this appliance on boats or in vehicles.

This appliance is intended for use up to a maximum height of 2000 metres above sea level.

This appliance is not intended for operation with an external clock timer or a remote control.

Do not use inappropriate child safety shields or hob guards. These can cause accidents.

This appliance may be used by children over the age of 8 years old and by persons with reduced physical, sensory or mental capabilities or by persons with a lack of experience or knowledge if they are supervised or are instructed by a person responsible for their safety how to use the appliances safely and have understood the associated hazards.

General maintenance works of the appliance must be undertaken by our trained registered gas installers.

Keep children below the age of 8 years old at a safe distance from the appliances and power cable.

Close the safety valve on the gas supply line if the appliances will not be used for a prolonged period.

Important safety information

Warning - WHAT TO DO IF YOU SMELL GAS!

Escaping gas may cause an explosion.

If you smell gas or notice any faults in the gas installation:

- Immediately shut off the gas supply.
- Immediately extinguish all naked flames and cigarettes.
- Do not turn on or turn off any light or appliance switches and do not pull any plugs out of sockets. Do not use any telephones or mobile phones within the building.
- Open windows and ventilate the room.
- Call the after-sales service or the gas supplier.

Warning - Risk of asphyxiation!

The use of a gas cooker leads to a build-up of heat, moisture and products of combustion in the room where the appliance is installed. Ensure that the installation room is well ventilated. The natural ventilation openings must be kept open or a mechanical ventilation device must be provided (e.g. an extractor hood). Intensive and persistent use of the appliance may mean that it is necessary to have additional ventilation (e.g. opening a window), or more effective ventilation (e.g. operating the existing mechanical ventilation device at a higher setting).

Warning - Risk of fire!

- Hot oil and fat can ignite very quickly. Never leave hot fat or oil unattended. Never use water to put out burning oil or fat. Switch off the hotplate. Extinguish flames carefully using a lid, fire blanket or something similar.
- The hot plates become very hot. Never place combustible items on the hob. Never place objects on the hob.
- The appliance becomes very hot and flammable materials could catch fire. Never store or use flammable objects (e.g. spray cans, cleaning agents) under the appliance or in its immediate vicinity. Never place flammable items on or in the appliance.
- When gas hot plates are in operation without any cookware placed on them, they can build up a lot of heat. The appliance and the extractor

hood above it may become damaged or be set on fire. Grease residue in the filter of the extractor hood may ignite. Only operate the gas burners with cookware on them.

- If the burner does not ignite after 15 seconds, switch off the control knob and open the door or window in the room. Wait at least 1 minute before igniting the burner again.

Warning - Risk of burns!

- The appliance becomes hot during operation. Allow the appliance to cool down before cleaning.
- The hotplates and surrounding area (particularly the hob surround, if fitted) become very hot. Never touch the hot surfaces. Keep children at a safe distance.
- The accessible parts become very hot when in operation. Never touch hot parts. Keep children at a safe distance.
- When the appliance cover is closed, heat will accumulate. Only close the appliance cover when the appliance has cooled down. Never switch the appliance on with the appliance cover closed. Do not rest food on the appliance cover or use it to keep food warm.
- Empty cookware becomes extremely hot when set on a gas hotplate that is in operation. Never heat up empty cookware.

⚠ Warning - Risk of injury!

- Incorrect repairs are dangerous. Repairs may only be carried out, and damaged power and gas lines replaced, by a registered gas installer trained by us. If the appliance is faulty, unplug the mains plug or switch off the fuse in the fuse box. Shut off the gas supply. Contact the after-sales service.
- Faults or damage to the appliance are dangerous. Never switch on a faulty appliance. Unplug the appliance from the mains or switch off the circuit breaker in the fuse box. Shut off the gas supply. Contact the after-sales service.
- Unsuitable pan sizes, damaged or incorrectly positioned pans can cause serious injury. Observe the instructions which accompany the cookware.

⚠ Warning - Risk of electric shock!

- Incorrect repairs are dangerous. Repairs may only be carried out by one of our trained registered gas installers. If the appliance is faulty, unplug the mains plug or switch off the fuse in the fuse box. Contact the after-sales service.
- The cable insulation on electrical appliances may melt when touching hot parts of the appliance. Never bring electrical appliance cables into contact with hot parts of the appliance.
- Do not use any high-pressure cleaners or steam cleaners, which can result in an electric shock.
- A defective appliance may cause electric shock. Never switch on a defective appliance. Unplug the appliance from the mains or switch off the circuit breaker in the fuse box. Contact the after-sales service.

Causes of damage

Caution!

- **Risk of heat damage to adjacent appliances or kitchen units:** If the appliance is in operation for an extended period, heat and moisture will be generated. Additional ventilation is required. Open the window or switch on an extractor hood that discharges the extracted air and moisture outside the building.
- **Risk of damage to the appliance due to the build-up of heat:** Do not heat roasters, frying pans or grill stones using more than one burner at a time.
- **Malfunction:** Always turn the control knob to the "Off" position when the appliance is not being used.

Environmental protection

The sections below list a number of energy-saving tips and provide information on disposing of your appliance.

Saving energy

- Choose a burner of roughly the same size as your pan. Place the cookware in the middle.
- Use small saucepans for small quantities. Using a large saucepan with little in it consumes a lot of energy.
- Always place suitable lids on saucepans. Cooking without a lid consumes significantly more energy. Use a glass lid so that you can see into the pan without having to lift the lid.
- Cook with only a little water. This will save energy and preserve the vitamins and minerals in vegetables.
- Switch to a lower heat setting in good time. This will save energy.

Environmentally-friendly disposal

Dispose of packaging in an environmentally-friendly Manner.

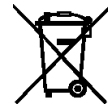

This appliance is labelled in accordance with European Directive 2012/19/EU concerning used electrical and electronic appliances (waste electrical and electronic equipment - WEEE). The guideline determines the framework for the return and recycling of used appliances as applicable throughout the EU.

Familiarising yourself with your appliance

Gas hob

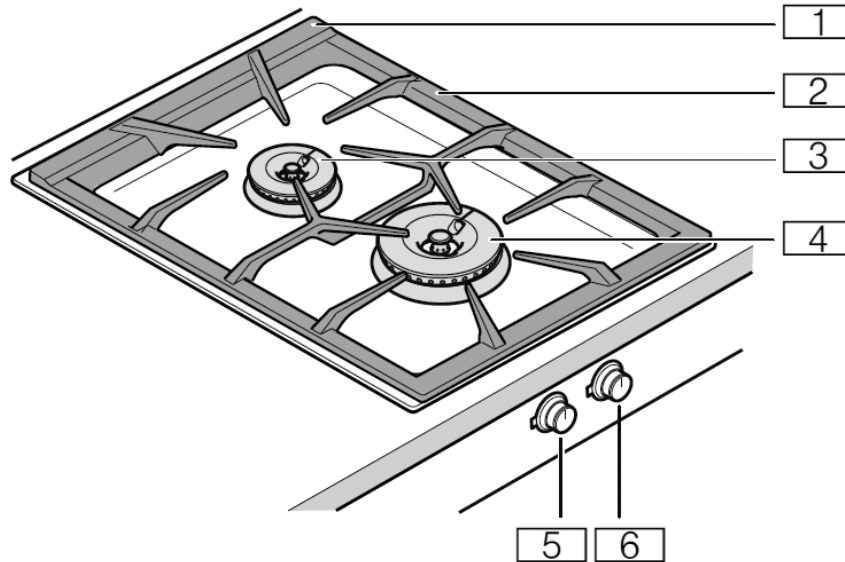

1. Ventilation openings (underneath pan support)
2. Pan support
3. Standard output burner 2.2 kW (HK Town Gas)
4. High output burner 4.5 kW (HK Town Gas)
5. Control knob, front burner
6. Control knob, rear burner

Control knob

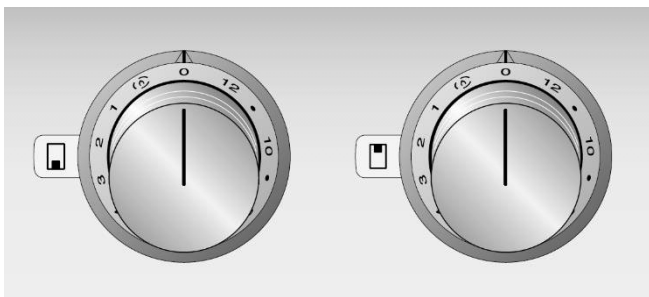

The markings show the position of the corresponding burner and the setting between level 1 to 12 or simmering (D).

Visual signals of the luminous disc

The control knob is encircled by an illuminated ring that indicates a number of statuses and functions.

Indicator	Meaning
○ Off	Appliance off
● Lit continuously orange	Appliance on
☀ Flashing orange	Appliance off Residual heat indicator
☀ Flashing orange and white alternately	Safety shut-off, power failure
☀ Flashing yellow and magenta alternately	Appliance fault Call the after-sales service.
● Lit green and then yellow for some seconds	Appliance initialising, only after first installation or power failure

Installation accessories

AA 414 010	Ventilation molding for operation next to downdraft ventilation VL 414
VA 420 000	Connection strip for combination with other Vario 400 appliances for flush installation
VA 420 001	Connection strip for combination with other Vario 400 appliances for flush installation with appliance cover/extension
VA 420 010	Connection strip for combination with other Vario 400 appliances for surface installation
VA 420 011	Connection strip for combination with other Vario 400 appliances for surface installation with appliance cover/extension
VA 440 010	Stainless steel appliance cover
VA 450 401	Appliance extension, 38 cm

Special accessories

You can order the following special accessories from your specialist dealer:

AA 414 010	Ventilation molding for operation next to downdraft ventilation VL 414
------------	--

Only use the accessories as specified. The manufacturer accepts no liability if these accessories are used incorrectly.

Individual parts of the wok burner

Ensure that the individual parts of the wok burner are fitted in the correct position and are straight; otherwise, this may result in ignition problems or problems during operation.

Fit the burner head and the burner ring in such a way that the latches on the lower section of the burner click into place in the corresponding slots. The alignment of the burner head and the burner ring is not important.

Note: If the burner parts are fitted at an angle, the appliance will not work.

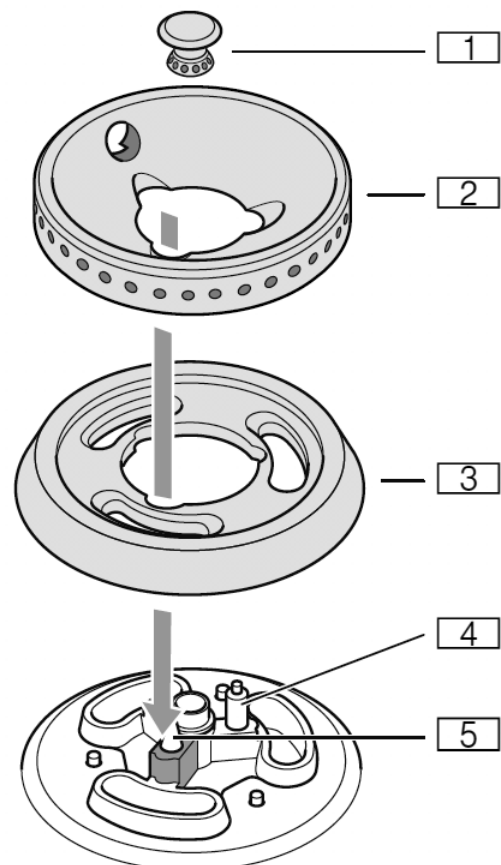

1. Burner cap
2. Burner ring
3. Burner head
4. Ignition plug
5. Thermocouple

Operating the appliance

Notes

- Only use the accessories specified. Do not line the stainless steel recess (e.g. with aluminium foil).
- The burner and ignition plug must be clean and dry.
- Only light the hotplates if the pan supports and all burner parts are correctly fitted.
- Do not touch the ignition plug while the gas appliance is being lit.
- It is important to keep the appliance clean. If the ignition plugs are dirty, this may cause ignition problems. Clean the ignition plugs regularly with a small, non-metallic brush. Take care to prevent the ignition plugs from suffering any heavy knocks.
- Do not cover the ventilation openings on the rear of the gas hob. Lack of ventilation will result in damage to the hob.
- When the gas cooktop is switched on, the electronics open up the gas supply, which produces a short sound. This is normal.
- In the event of a power failure, the appliance will not work. The gas supply is shut off.

Switching on

Your gas hob has an automatic quick-ignition function.

1. Place a suitable item of cookware on the pan support.
2. Push in the control knob for your chosen burner and turn it clockwise or anti-clockwise to the heat setting you require.

The burner ignites automatically.

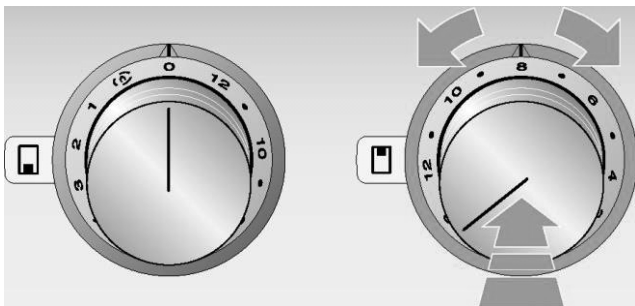

Turn the control knob to set the heat setting.

⚠ Warning – Risk of deflagration!

If the burner does not ignite after 15 seconds, switch off the control knob and open the door or window in the room. Wait at least 1 minute before igniting the burner again.

Simmer setting

With the simmer setting, the burner switches the gas flame on and off. This allows you to melt chocolate or heat up delicate sauces, for example.

Turn the control knob to . It takes 10-50 seconds to switch on or off.

Electronic flame monitoring and automatic re-ignition

For your safety, the hob has an electronic flame monitoring system. If the flame goes out while the hob is in use (e.g. due to a draught), the appliance will automatically re-ignite the burner.

If re-ignition is unsuccessful (e.g. because liquid or food has boiled over and remains on the burner), the appliance will switch off the gas supply. The illuminated ring behind the control knob will flash.

Turn the control knob to 0. Wait until the appliance is cool enough and then check whether all the burner parts are in the correct position. Check whether the burner or the ignition plug are covered in food remnants etc. → "Trouble shooting" on page 13

Switching off

Turn the control knob to position 0. The appliance electronics will shut off the gas supply.

⚠ Warning – Risk of burns!

When the appliance cover (optional accessory) is closed, heat will accumulate. Only close the appliance cover when the appliance has cooled down. Never switch the appliance on with the appliance cover closed. Do not rest food on the appliance cover or use it to keep food warm.

Residual heat indicator

The luminous disc behind the control knob flashes after switching off, to indicate that the appliance has still not cooled down to such an extent that it can be touched safely.

Safety shut-off

For your safety, the appliance has a safety shut-off function. The appliance is automatically switched off if it has been in operation for an extended period. How long the appliance waits before switching itself off depends on the setting (setting 12 = 1 hour, setting 1 = 4 hours). The illuminated ring behind the control knob will flash orange and white alternately.

Turn the control knob to 0. You will now be able to start the appliance again as usual.

Table of settings and tips

Heat setting	Cooking method	Examples
12	Heating	Water, clear soups
	Blanching	Vegetables
10-12	Searing	Meat, wok dishes/ pan-fried dishes
	Frying at high temperatures	Meat, potatoes
7-10	Simmering with the lid open	Liquids, dough-based foods
6-8	Baking	Flour-based food
	Frying at medium temperatures	Poultry, fish
4-6	Frying at low temperatures	Fried sausages, onions, egg dishes
	Warming	Vegetables, soups, stews
	Deep-frying	Chips, pastries
	Poaching with the lid open	Dumplings, boiled sausages
3-4	Defrosting	Frozen food
	Braising	Beef olives, joints
	Stewing	Vegetables
2-4	Simmering with the lid on	Soups, vegetables
Simmer setting -up to 3	Soaking	Rice, rice pudding, cereals
Simmer setting	Melting, keeping warm	Chocolate, butter

Tips for cooking and roasting

The values given in the settings table must be looked upon as recommended values. The heat required depends not only on the type and condition of the food, but also the size and contents of the pot.

Due to the high performance of the cooktop, fat and oil will heat up quickly. Never leave the cooktop unattended, fat can ignite, food can burn.

Preferably use the rear cooking zones to prepare meals, that need longer to cook.

Preferably use the high output burners for brief cooking, deep fat frying and searing of large quantities.

Maximum weight of cookware placed on the front and rear burner shall not exceed 15 kg and 10 kg respectively.

Information and tips regarding cookware

The following information and tips have been provided to help you save energy and avoid damaging your cookware.

Suitable cooking vessels

Burner	Recommended pan base diameter	Minimum pan base diameter
Standard-output burner	200 - 240 mm	90 mm
High-output burner	240 - 280 mm	90 mm

Pans with a diameter of less than 90 mm or more than 280 mm should not be used. If you do use larger pans, these should not protrude beyond the edges of the appliance.

Maximum weight of cookware placed on the front and rear burner shall not exceed 15 kg and 10 kg respectively.

Precautions for use

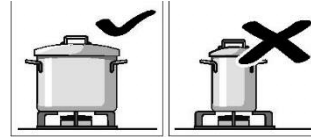

Use pots or pans which are the right size for each burner. Do not use small pots or pans on large burners. The flame should not touch the sides of the pot.

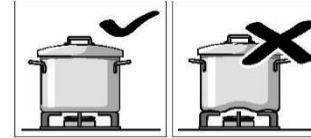

Do not use damaged pots or pans, which do not sit evenly on the cooktop, they may tip over. Only use pots or pans with a thick, flat base.

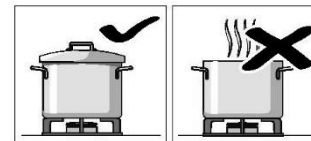

Do not cook without using a lid and make sure the lid is properly fitted. This wastes energy.

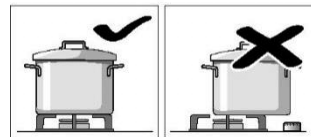

Always centre the pot or pan over the burner, otherwise it could tip over.

Do not place large pots on the burners near the control knobs. These may get damaged by the high temperatures.

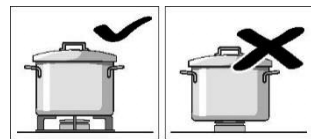

Place the pots or pans on the pan support, never directly on the burner. Make sure that the pan supports and burner caps are correctly positioned before using the appliance.

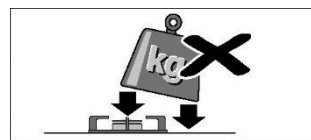

Pots or pans should be placed on the cooktop carefully. Do not strike the cooktop and do not place excessive weight on it.

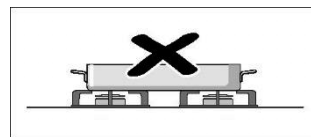

Do not heat a cooking vessel (e.g. roaster, pan, grill stone) on more than one burner at the same time. The resulting heat accumulation will damage the appliance.

Cleaning and maintenance

⚠ Warning - Risk of electric shock!

Do not use any high-pressure cleaners or steam cleaners, which can result in an electric shock.

⚠ Warning - Risk of electric shock!

The accessible parts become very hot when in operation. Never touch hot parts. Keep children at a safe distance.

Caution!

Risk of surface damage

Do not use these cleaners

- harsh or abrasive cleaning agents
- oven cleaners
- corrosive or aggressive cleaners, or those containing chlorine
- cleaning agents with a high alcohol content
- hard and scratchy sponges, brushes or scouring pads

If such an agent comes into contact with the appliance, wash it off immediately with water.

Thoroughly wash out new sponge cloths before using them!

Cleaning the appliance

Clean the appliance after each use once it has cooled down. Remove spilt liquids immediately and do not allow any food remains to burn on.

Make sure that the ventilation openings under the pan support are always clean. The ventilation openings must not be covered.

Dry the burners thoroughly after cleaning. Only operate the appliance when the burners are dry. Damp burners can cause ignition problems and/or an unstable flame.

During assembly, make sure that the burner parts (catch tappets) are in the correct position. All parts must be straight.

Appliance part/ surface	Recommended cleaning
Stainless steel surfaces	Use soapy water and dry with a soft cloth. Only use a minimal amount of water when cleaning so that no water enters the appliance. Soak burnt-on remains with a small amount of soapy water; do not scour. Remove heavy soiling or yellow discolouration caused by heat using our stainless steel cleaning agent (item no. 00311499).
Pan supports	Carefully remove them for cleaning. Soak in the sink. Clean using a scrubbing brush and detergent. Clean the area around the rubber buffers carefully so that they do not become detached. Rinse with clean water before leaving to dry. Do not clean them in the dishwasher.
Burner parts	Use soapy water and dry with a soft cloth. Make sure that the openings are not blocked. Take care that no small parts are lost. Do not clean them in the dishwasher.
Control knob	The soapy cloth must not be too wet. Dry with a soft cloth.

Burnt-on dirt

For hard-to-remove, burnt-on dirt, you can order a cleaning gel from our online shop, from your specialist retailer or our after-sales service (item number 00311859). It is suitable for pan supports and the stainless-steel recess. If necessary, let the dirt soak overnight. Follow the instructions on the cleaning agent.

Caution!

Damage to the surface

Do not use the cleaning gel on the burner parts.

Burner discolouration

After extended use, the brass burner parts take on a darker colour as a result of the oxidation process that occurs naturally. The discolouration does not affect their serviceability.

Trouble shooting

Malfunctions often have simple explanations. Please read the following notes before calling the after-sales service.

⚠ Warning - Risk of electric shock!

Incorrect repairs are dangerous. Repairs may only be carried out by one of our registered gas installer. If the appliance is faulty, unplug the mains plug or switch off the fuse in the fuse box. Contact the after-sales service.

Disruption	Possible cause	Solution
The burner will not ignite when it is switched on.	Power supply disconnected.	Turn all control knobs to 0. Check the fuse box to see whether the circuit breaker has tripped.
The burner will not ignite when it is switched on. The illuminated ring behind the control knob is flashing orange and white alternately.	Burner or gas supply fault.	Turn all control knobs to 0. Check: <ul style="list-style-type: none"> ● Are the burner parts positioned correctly? ● Is the main gas tap open? ● Is the burner clean and dry?
The burner will not ignite when it is switched on. The illuminated ring behind the control knob is flashing yellow and magenta alternately.	Electronics fault	Turn all control knobs to 0 and disconnect the appliance from the mains power supply for one minute (switch off the circuit breaker or pull out the plug). Reconnect the appliance. The illuminated rings around the control knobs will be lit green for a few seconds and then turn yellow. Wait until the illuminated rings switch off. Then turn any of the control knobs to any of the heat settings and then back to 0. Switch on the burner. If the illuminated ring starts flashing yellow and magenta again, call our after-sales service.
The burner goes out while the appliance is in operation. The illuminated ring behind the control knob is flashing orange and white alternately.	Safety switch-off function: No actions have been performed for an extended period.	Turn all control knobs to 0, and then switch them back on if you wish to continue using the appliance.
The burner goes out while the appliance is in operation. The illuminated ring behind the control knob is flashing orange and white alternately.	Domestic power failure: Following a power failure, the appliance will remain switched off for safety reasons.	Turn all control knobs to 0, and then switch them back on if you wish to continue using the appliance.
There is a smell of gas in the kitchen.	Gas may be leaking out.	Check that the gas connection is not leaking. Open windows and ensure the room is well ventilated.
The appliance paneling becomes slightly raised at the corners when it is in operation.	The metal from which the cooktop is made expands as it heats up.	This is normal. It will contract again once it has cooled down.

Notes

- Each time the mains power is switched on or following a power failure, a sound is produced when the gas valves are started up. The illuminated rings around the control knobs will be lit green for a few seconds and then turn yellow. Wait until the illuminated rings switch off.

- When the gas cooktop is switched on, the electronics open up the gas supply, which produces a short sound. A sound can also be heard when the setting is changed. This is normal.

After-sales service

Our after-sales service is there for you if your appliance needs to be repaired. We will always find an appropriate solution, also in order to avoid after-sales personnel having to make unnecessary visits.

E number and FD number

When calling us, please quote the full product number (E no.) and the production number (FD no.) so that we can provide you with the correct advice. The rating plate that features these numbers can be found on the underside of the appliance.

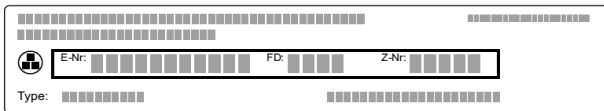

To save time, you can make a note of the numbers for your appliance and the telephone number of the after-sales service in the space below in case you need them.

E no.	FD no.
--------------	---------------

After-sales service ☎

Please note that a visit from a registered gas installer is not free of charge in the event that the appliance has been misused, even during the warranty period.

Please find the contact data of all countries in the enclosed customer service list.

To book an engineer visit and product advice

HK 2553 8353

Trust the expertise of the manufacturer, and rest assured that the repair will be carried out by registered gas installer using original spare parts for your domestic appliance.

目錄

關於產品、配件、備品與保養的其他資訊，請參閱
www.gaggenau.com 與線上商店
www.gaggenau.com/zz/store

使用前須知	16
重要安全訊息	17
損壞原因	17
環境保護	18
節省能源	18
合環保規定的廢棄物處理	18
了解您的爐具	19-20
煤氣爐	19
控制旋鈕	19
照明裝置的視覺信號	19
安裝配件	20
特殊配件	20
爐頭的個別零件	20
操作爐具	21
開啟	21
煨燉設定	21
電子式火候監控與自動再點火	21
關閉	21
餘溫指示燈	21
安全關機	21
設定表與提示	22
烹調與燒烤的秘訣	22
於鍋具的提示與資訊	23
適用的烹調工具	23
使用時的注意事項	23
清潔與保養	24
清潔本爐具	24
燒焦的污物	24
爐頭泛黃	24
疑難排解	25
售後服務	26
產品編號及生產編號	26

使用前須知

詳細閱讀說明才可以安全並正確地使用本產品請妥善保管說明手冊及安裝說明，以便您在日後或供下一位使用者查閱。

本爐具必須完整地安裝於廚房中。請遵照特定的安裝說明。

本爐具必須根據隨附的安裝說明書進行安裝。

打開包裝後，請檢查爐具有否損壞。如爐具在運送過程中受損，請切勿安裝。

根據香港氣體安全條例，任何氣體裝置工程，包括爐具和接駁喉管的安裝，必須由註冊氣體裝置技工執行，而該技工已於相關的氣體工程類別註冊和受聘於註冊氣體工程承辦商。

務必由註冊氣體裝置技工將爐具接電。保養不包括因不當連接而造成的損壞。

此爐具只供家庭及家居環境中使用。本爐具僅適用於準備食物和飲品，不可當做暖爐來使用。爐具運轉時，請勿離開不理。僅供室內使用。

請不要將本爐具安裝在船隻或運輸工具上。

本爐具僅適用於最高海拔2000米以下地區。

本爐具不適合與外部計時器或遙控操作搭配使用。

請勿使用不適當的兒童安全防護罩或爐頭保護器具。這些可能會導致意外事故。

8歲以上兒童、身體、感官或心智能力欠佳者、或欠缺使用經驗與知識者，在使用本爐具時，須由負責其安全並明瞭相關風險之人士從旁監督或指導，以安全地使用爐具。

只可由我們受過訓練的註冊氣體裝置技工執行爐具維修工作。

8歲以下的兒童應與爐具和電源線保持安全的距離。

若爐具將有一段長時間不使用，請關閉煤氣供給管線上的安全閥。

⚠ 重要安全訊息

⚠ 警告 - 聞到煤氣味時該做的事！

氣體洩漏可能會導致爆炸。

若聞到煤氣味或發現氣體安裝上有缺陷：

- 立刻關閉氣體供應。
- 立刻滅掉所有暴露出的火焰與煙霧。
- 請勿開啟或關閉任何光源或爐具電源，以及將任何插頭從插座拔掉。請勿在建築物裡使用電話或手機。
- 打開窗戶並使房間內通風。
- 請聯絡售後服務中心或煤氣供應商。

⚠ 警告 - 窒息風險！

使用氣體煮食爐將會導致安裝有本爐具的房間內產生熱、濕氣及燃燒產物。請確保安裝本爐具的房間內有足夠的通風。請務必將通風口打開或使用機械式抽風機（例如抽油煙機）。若密集地或持續地使用本爐具，需有額外的通風（例如打開窗戶）或更有效的通風（例如將既有的機械式抽風機開大一點）。

⚠ 警告 - 火災風險！

- 熱油和脂肪會快速燃燒。務必注意熱脂肪或油的使用。切勿使用水澆熄正在燃燒的油或脂肪。關閉發熱的爐面。小心使用蓋子、滅火毯或類似的物品來滅火。
- 發熱的爐面變得非常熱。切勿將易燃物品放置於爐頭上。切勿將物品放置於爐頭上。
- 爐具過熱的話，可能會使易燃物著火。請勿在本爐具的下方或鄰近處放置或使用易燃物品（例如噴罐、清潔劑）。請勿在本爐具的上方或內部放置易燃物品。
- 如果氣體爐頭在運轉中沒有放置任何廚具，爐頭會產生高溫。本爐具與其上方的抽油煙機可能會損壞或起火。抽油煙機的濾網上所殘留的油脂可能會引起點火。因此，必須在放上廚具後才操作煤氣爐頭。
- 假如爐頭在15秒後，還是沒有點燃，關掉爐頭，並開啟房間內的窗或門。再次開啟爐頭前，需等待至少1分鐘。

⚠ 警告 - 灼傷風險！

- 爐具在運轉時會變得很熱。清潔前，請務必等待爐具完全冷卻。
- 發熱的爐面及周圍區域（特別是爐頭附近區域）會變得非常熱。請勿觸碰高溫表面。請勿讓兒童走近此爐具。
- 運轉時可接觸部分會變得非常灼熱。請勿碰觸。請勿讓兒童走近此爐具。
- 當爐具的蓋子（自選配件）關閉時，熱能會累積。請在本爐具完全冷卻後再關閉爐具的蓋子。請勿在爐具蓋子蓋上的狀態下開啟本爐具的電源。請勿將食物放在爐具蓋子上或使用蓋子來保溫食物。
- 空鍋具放在運轉中的煤氣加熱板上會變得非常

燙。請勿加熱空的鍋具。

⚠ 警告 - 受傷風險！

- 不當維修會造成危險。請由受過本公司訓練的註冊氣體裝置技工進行維修或更換損壞的電源、煤氣管線。爐具如有故障，請拔掉爐具插頭或關掉保險絲盒內的保險絲。關閉煤氣供給。請聯絡售後服務中心。
- 有缺陷或損傷的爐具非常危險。爐具若有缺陷請勿開啟其電源。請拔掉爐具插頭或關掉保險絲盒內的斷路器。關閉煤氣供給。請聯絡售後服務中心。
- 尺寸不合適的平底鍋、已受損或沒放置好的平底鍋將導致受傷。請遵照鍋具隨附的指示。

⚠ 警告 - 觸電風險！

- 不當維修會造成危險。爐具只可由我們受過訓練的註冊氣體裝置技工維修。爐具如有故障，請拔掉主電源插頭或關閉保險絲盒內的保險絲。請聯絡售後服務中心。
- 爐具的電線絕緣部分會因接觸爐具高溫部分而溶化。切勿讓電線接觸爐具高溫的部分。
- 請勿使用任何高壓清潔器或蒸氣清洗機，以免觸電。
- 損壞的爐具可能導致觸電。請勿開動損壞的爐具。請拔掉爐具插頭或關閉保險絲盒內的斷路器。請聯絡售後服務中心。請聯絡售後服務中心。

損壞原因

注意！

- **對鄰近爐具或廚房用具造成熱損壞：**當爐具運轉了一段時間後會產生熱與濕氣。需要有額外的通風。打開窗戶或啟動抽油煙機將抽出的空氣及溼氣排放到建築物外面。
- **因熱能累積會導致爐具損壞：**請勿一次使用一個以上的爐頭來加熱烤盤、平底鍋或燒烤石。
- **故障：**當爐具沒有使用時，請總是將控制旋鈕轉至「關閉」位置。

下一個章節裡，我們明列了節能秘訣與爐具廢棄處理相關資訊。

節省能源

- 選擇和您的平底鍋大小差不多的爐頭。將鍋具置於中央。
- 少量烹調時請使用小型平底深鍋。少量烹調時使用大型平底深鍋會消耗過多的能源。
- 使用適合平底深鍋的蓋子。不加蓋烹調將會消耗較多的能量。使用玻璃蓋可讓你不用打開蓋子便能看到鍋中的情況。
- 使用少量的水烹調。這可以節省能源並保留蔬菜中所有的維生素和礦物質。
- 適時切換至較低的加熱設定。如此可以節省能源。

合環保規定的廢棄物處理

以環保方式處理包裝。



此爐具根據歐盟關於使用過的電器及電子產品的指令2012/19/EU（棄置的電器及電子產品-WEEE）貼有相關標籤。該指引訂明了在歐盟範圍內舊電器退還及回收的方法。

煤氣爐

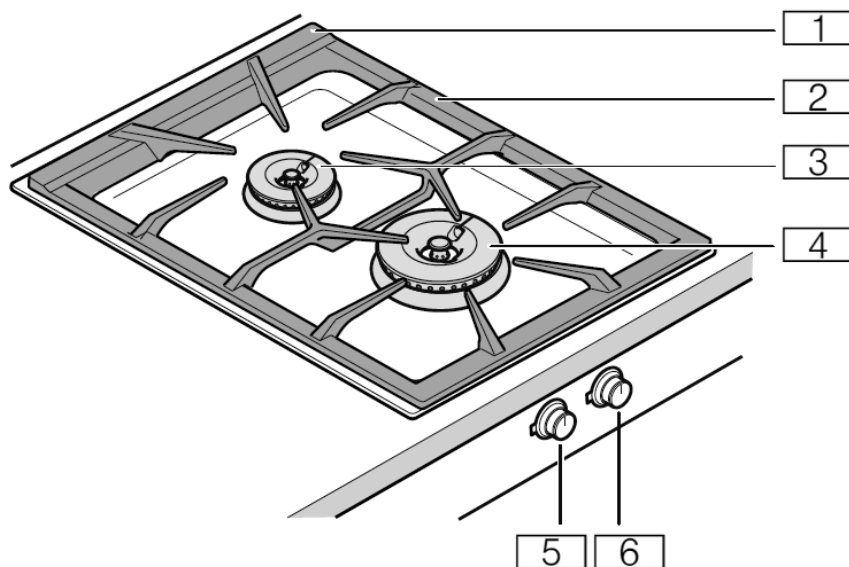

1. 通風口（爐架下方）
2. 爐架
3. 標準爐頭 2.2 kW（HK 中華煤氣）
4. 高功率爐頭 4.5 kW（HK 中華煤氣）
5. 控制旋鈕，前方爐頭
6. 控制旋鈕，後方爐頭

控制旋鈕

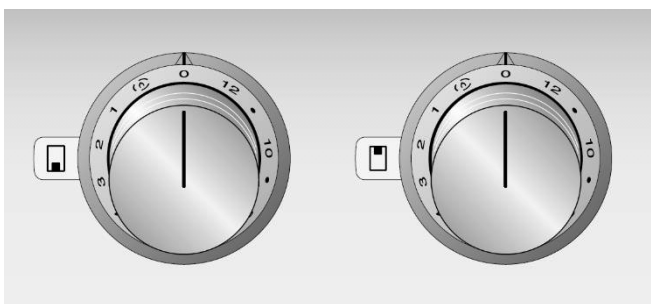

這些標示顯示相對應的燃燒器位置以及 1 到 12 級之間或煨燉設定 (D).

照明裝置的視覺信號

環繞控制旋鈕周圍的發光圓環代表各種狀態和功能。

指示燈	說明
○ 關閉	爐具關閉
● 持續亮橙燈	爐具開啟
☀ 閃爍橙燈	爐具關閉 餘溫指示燈
☀ 交替閃爍橙燈和白燈	安全關機，停電
☀ 交替閃爍黃燈和紅燈	爐具故障 請致電售後服務中心。
先亮綠燈，然後亮幾秒黃燈	爐具正在初始化中， 只發生在首次安裝，或是停電之後

安裝配件

- AA 414 010 用於下置型氣流通風爐具VL 414旁邊的通風嵌條
- VA 420 000 用來組合其他Vario 400爐具以進行齊平安裝的连接條
- VA 420 001 用來組合其他Vario 400爐具以和爐具護蓋/延長線進行齊平安裝的连接條
- VA 420 010 用來組合其他Vario 400爐具以進行表面安裝的连接條
- VA 420 011 用來組合其他Vario 400爐具以和爐具護蓋/延長線進行表面安裝的连接條
- VA 440 010 不銹鋼爐具的護蓋
- VA 450 401 爐具延長線，38 cm

特殊配件

可向專業零售商購買以下的特殊配件。

- AA 414 010 用於下置型氣流通風爐具VL 414旁邊的通風嵌條

請勿使用指定配件以外的物品。若這些配件使用不正確，製造商將不對此負起任何責任。

爐頭的個別零件

請確保炒鍋爐頭的個別零件皆安裝於正確位置，且平直無彎曲，否則可能出現點火或操作問題。

請固定爐頭前端和爐環，以便讓爐頭下半部的固定鎖能扣入對應的插槽內。爐頭前端是否對齊爐環並不重要。

提示：如果爐頭組件是依某種角度裝入，爐具將無法使用。

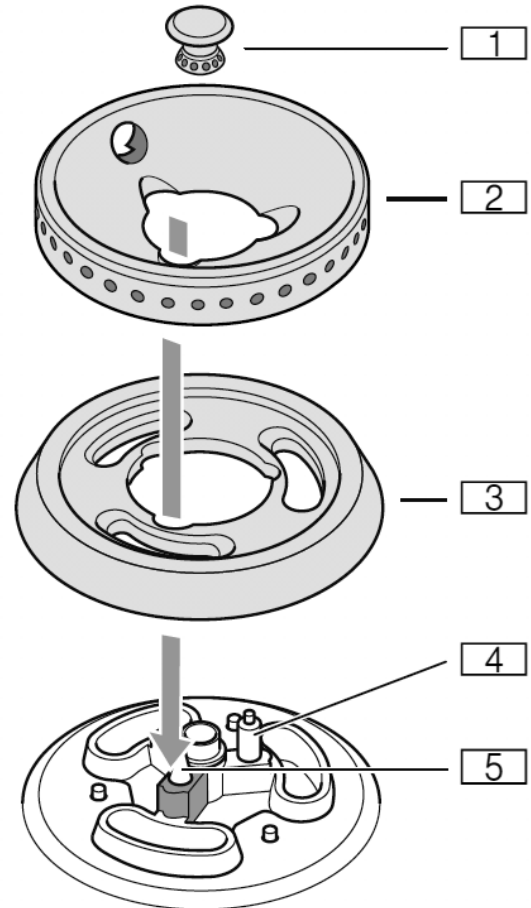

- 1 | 爐蓋
- 2 | 爐環
- 3 | 燃燒爐頭
- 4 | 點火器
- 5 | 熱電偶

操作爐具

提示

- 僅使用指定配件。請勿蓋住不銹鋼凹槽（例如用鋁箔蓋住）。
- 爐頭和點火器必須保持清潔乾燥。
- 請先確認爐架和所有爐頭組件都已正確安裝，再點燃發熱的爐面。
- 當煤氣爐具正在點燃時，請勿碰觸點火器。
- 您必須保持爐具清潔。如果點火器太髒，可能會造成點火問題。定期使用小型非金屬刷子清潔點火器。請小心維護，避免點火器受到嚴重撞擊。
- 當使用炒鍋烹煮時，將炒鍋架放在炒鍋爐頭的爐架上。烹飪時確保炒鍋可穩定放在炒鍋架上。
- 切勿蓋住煤氣爐後方的通風口。缺乏散熱會引致爐具損毀。
- 啟動煤氣爐後，當電子部件打開煤氣供給時會聽到一個短促聲音。這是正常現象。
- 發生停電時，爐具將無法運作。爐具會關閉煤氣供給。

開啟

煤氣爐附有自動快速點火功能。

1. 請在爐架上放置適當的鍋具。
2. 按壓所選燃燒器的控制旋鈕，並順時鐘或逆時鐘轉動它到您需要的加熱設定。爐頭將自動點火。

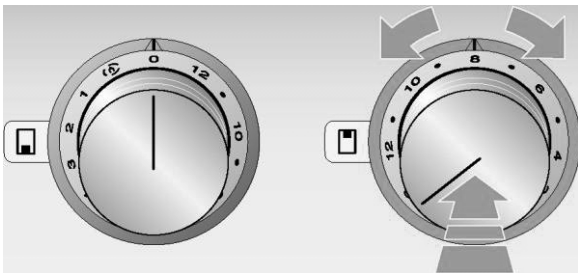

旋轉控制旋鈕來進行加熱設定。

⚠ 警告 - 爆燃風險！

假如在 15 秒後，爐頭還是沒有點燃，關掉爐頭，並開啟房間內的窗或門。再次開啟爐頭前，需等待至少 1 分鐘。

煨燉設定

透過煨燉設定，可切換爐頭火侯的開啟和關閉。您可藉此溶化朱古力或為調製的醬汁加熱等。

將控制旋鈕轉到 。切換開關會需要 10 到 50 秒時間。

電子式火候監控與自動再點火

煤氣爐上附有電子式火候監控系統以保護您的安全。煤氣爐使用中若火熄滅（例如因為有風），本爐具的爐頭將自動再點火。

如果無法重新點火（例如因為液體或食物溢出，而且殘渣留在爐頭上），本爐具會關閉煤氣供給，同時在控制旋鈕後方的發光圓環將會閃爍。

將控制旋鈕轉至 0。待本爐具冷卻至適當溫度後，再確認是否所有爐頭組件的位置均正確。檢查爐頭或點火器是否被食物殘渣等所覆蓋。→ “疑難排解” 第 25 頁

關閉

請將控制旋鈕轉至 0 的位置，本爐具的電子部件將會關閉煤氣供給。

⚠ 警告 - 燙傷風險！

當爐具的蓋子（自選配件）關閉時，熱能會累積。請在本爐具完全冷卻後再關閉爐具的蓋子。請勿在爐具蓋子蓋上的狀態下開啟本爐具的電源。請勿將食物放在爐具蓋子上或使用蓋子來保溫食物。

餘溫指示燈

關機後控制旋鈕後方的照明裝置閃爍，此意味爐具尚未降溫至可安全碰觸的程度。

安全關機

本爐具附有安全關閉裝置以保護您的安全。爐具運轉了一段長時間後會自動關閉。爐具會依據設定（設定 12 = 1 小時，設定 1 = 4 小時），決定要等候多久時間後關閉。控制旋鈕後方的發光圓環會交替閃爍橙燈和白燈。

將控制旋鈕轉動到 0 的位置。現在您可以如常重新啟動爐具。

設定表與提示

加熱設定	烹調方法	例如
12	加熱	水，清湯
	盪煮	蔬菜
10-12	燒炙	肉類、炒菜/平底鍋油煎料理
	高溫油炸	肉、馬鈴薯
7-10	打開鍋蓋煨燉	汁液、麵糰類食物
6-8	烘焙	麵粉類製品
	以適中溫度油煎	家禽、魚類
4-6	低溫油煎	油煎香腸、洋蔥、蛋類料理
	加熱	蔬菜、湯、燉菜
	油炸	炸馬鈴薯條、酥皮點心
	打開鍋蓋水煮	餃子、煲煮過的香腸
3-4	解凍	冷凍食物
	以文火燉煮	牛肉橄欖、排骨肉
	燉	蔬菜
2-4	加蓋煨燉	湯、蔬菜
煨燉設定- 最局為3	煮	米、米飯布甸、穀類
煨燉設定	融化、保溫	朱古力、牛油

烹調與燒烤的秘訣

設定列表裡的數值僅能當做參考數值。所須的加熱不僅依照食物的類型與狀態有所不同，也受到鍋子的尺寸與內裝物的影響。

由於本產品為高效能煤氣爐，因此可快速加熱油脂和油。請千萬不可放置煤氣爐不管，油脂可能會引發點火，食物可能會燒起來。

最好能使用後方烹調區來準備肉品，會花比較久的時間。

最好能使用高功率爐頭來料理快速烹調食物、油炸以及大量燒炙食物。

關於鍋具的提示與資訊

以下提供您節能並防止鍋具損壞的資訊和秘訣。

適用的烹調工具

爐頭	建議平底鍋底部直徑	最小平底鍋底部直徑
標準爐頭	200-240 mm	90 mm
高功率爐頭	240-280 mm	90 mm

不應使用直徑少於90mm或是大於280mm的平底鍋。如果您是使用較大的平底鍋，其直徑不應超過爐具的邊緣。

放置在前後爐頭上的爐具最大重量分別不得超過15公斤和10公斤。

使用時的注意事項

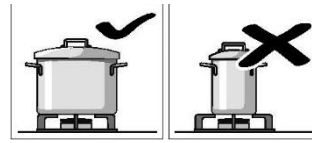

請使用適合各爐頭尺寸的鍋子或平底鍋。請勿在大的爐頭上使用過小的鍋子或平底鍋。火焰不可碰觸到鍋子的邊緣。

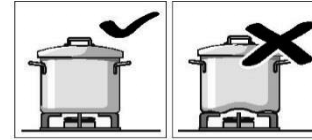

請勿使用已損壞的鍋子或平底鍋，這樣的器具無法在煤氣爐上平均放置而可能導致傾斜外漏。請務必使用帶有厚平底的鍋子或平底鍋。

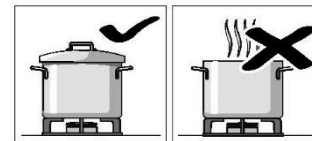

請勿在沒有使用蓋子的狀態下烹調並確保蓋子的尺寸合適。如此會造成能源浪費。

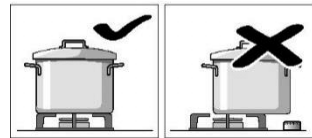

請務必將鍋子或平底鍋擺放在爐頭的中間，否則會傾斜外漏。請勿在靠近控制旋鈕的爐頭上放置過大的鍋子。這些部分可能會因為高溫而損壞。

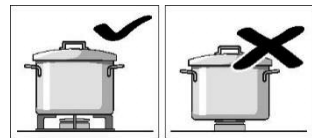

將鍋子或平底鍋放置於爐架上，務必不要直接放在爐頭上。使用本爐具前請確認爐架與爐蓋的位置有擺放正確。

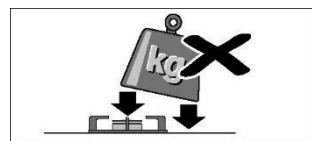

鍋子或平底鍋必須小心地放置在煤氣爐上。請勿敲打本煤氣爐以及於上方放置過重的物品。

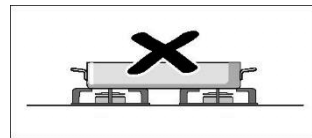

請勿同時使用一個以上的爐頭來加熱烹調器具(例如烘烤器、平底鍋、燒烤石)。所有加熱的累積能量將導致爐具損壞。

清潔與保養

△ 警告 - 觸電風險！

請勿使用任何高壓清潔器或蒸氣清洗機，以免觸電。

△ 警告 - 燙傷風險！

運轉時可接觸部分會變得非常灼熱。請勿碰觸。請勿讓兒童走近此爐具。

注意！

小心損害表面

請勿使用以下的清潔用品

- 強效或腐蝕性的清潔劑
- 爐用清潔劑
- 腐蝕性、強效或含氯的清潔劑
- 含高酒精成份的清潔劑
- 硬質與易刮傷的海綿、刷子或百潔布

若爐具不慎接觸到此類清潔劑，請立即用清水洗淨。

新的海綿布在使用前應先徹底清潔！

清潔本爐具

每次使用完請在爐具冷卻後做清潔。請立即清除溢出的液體並且不要讓任何食物殘渣燒起來。

請確認在爐架下方的通風口保持在乾淨的狀態。通風口絕不能被覆蓋住。

於清潔完成後，徹底抹乾爐頭。請務必在爐頭乾燥的狀態下操作本爐具。潮濕的爐頭將導致點火問題與/或火候不穩定。

安裝時請確保爐頭組件（固定挺桿）在正確的位置。所有組件必須是平直無彎曲的。

爐具組件/表面	推薦的清潔方式
不銹鋼表面	請使用肥皂水清潔並以軟布擦乾。請確保清潔時使用最少量的水以避免水滲入爐具內。請將燒焦的殘渣浸泡在少量的肥皂水裡，並請不要刷洗。請使用本公司的不銹鋼清潔劑（項目編號00311499）來去除頑強污垢或因熱所導致的泛黃。
爐架	清潔時，可小心地取下爐架。浸泡在水槽中。請用刷子與清潔劑清洗。請小心清潔橡膠緩衝條的四周以避免其脫落。放置乾燥前請先用清水沖洗乾淨。 請勿放入洗碗機內清洗。
爐頭組件	請使用肥皂水清潔並以軟布擦乾。請確保開口處沒有阻塞。請注意沒有遺失任何小組件。請勿放入洗碗機內清洗。
控制旋鈕	沾有肥皂水的布不可太濕。用軟布擦乾。

燒焦的污物

針對難以清除的燒焦污物，可向網上商店、專業零售商或售後服務中心購買清潔凝膠（品項編號00311859）。本清潔凝膠適用於爐架與不銹鋼凹槽。若有需要可將污物浸泡過夜。請遵循清潔劑上的指示。

注意！

造成表面損壞

請勿將清潔凝膠用於爐頭的組件上。

爐頭泛黃

長期使用後，黃銅製的爐頭組件會因為自然發生的氧化作用而呈現較暗的顏色。此泛黃現象並不會影響其功能。

疑難排解

大多數故障都可以輕易地解決。在聯絡客戶服務前，請先閱讀下列說明。

⚠ 警告 - 觸電風險！

不當維修會造成危險。爐具只可由我們受過訓練的註冊氣體裝置技工維修。爐具如有故障，請拔掉主電源插頭或關閉保險絲盒內的保險絲。請聯絡售後服務中心。

損毀	可能原因	解決方法
爐頭無法點火。	電源供應器已被切斷。	將所有的控制旋鈕轉至 0。請檢查保險絲盒內的斷路器是否故障。
爐頭無法點火。 控制旋鈕後方的發光圓環會交替閃爍橙燈和白燈。	爐頭或煤氣供給故障。	請將所有的控制旋鈕轉至 0。 檢查： <ul style="list-style-type: none">● 爐頭組件是否安裝在正確的位置？● 主要煤氣開關是否已打開？● 爐頭是否清潔乾燥？
爐具在使用時爐頭熄滅。 控制旋鈕後方的發光圓環會交替閃爍橙燈和白燈。	電子裝置故障	將所有的控制旋鈕轉至 0，切斷爐具的電源供應一分鐘（關掉斷路器或拔掉爐具插頭）。重新接上爐具。控制旋鈕周圍發光圓環會亮起綠燈，數秒鐘後轉為黃燈。請靜候發光圓環關閉。然後將任一控制旋鈕轉至其中一個加熱設定，再轉回 0 的位置。 開啟爐頭。如果發光圓環又再次開始閃黃燈和紅燈，請致電售後服務中心。
爐具在使用時爐頭熄滅。 控制旋鈕後方的發光圓環會交替閃爍橙燈和白燈。	安全關閉功能： 爐具長時間無動作。	將所有的控制旋鈕轉至 0，如果要繼續使用爐具，可以將它們重新開啟。
爐具在使用時爐頭熄滅。 控制旋鈕後方的發光圓環會交替閃爍橙燈和白燈。	住家停電： 停電後，為了安全起見，爐具仍會關閉。	將所有的控制旋鈕轉至 0，如果要繼續使用爐具，可以將它們重新開啟。
廚房裡有煤氣味。	煤氣有可能外漏。	請檢是否有煤氣外漏。打開窗戶，並確保房間內有足夠的通風。
爐具在使用時面板的角落會微微上揚。	煤氣爐所使用的金屬材質在力加熱時會膨脹。	這是正常現象。金屬在冷卻後會再次收縮。

提示

- 每次啟動主電源或是停電之後，當煤氣閥啟動時，會發出聲音。控制旋鈕周圍發光圓環會亮起綠燈，數秒鐘後轉為黃燈。請等候發光圓環關閉。
- 啟動煤氣爐後，當電子部件打開煤氣供給時會聽到一個短促聲音。設定變更時，也會聽到一個聲音。這是正常現象。

售後服務

若爐具需要維修，請聯絡我們的售後服務中心。我們一定會找出適合的解決方案，同時避免售後服務人員不必要的上門服務。

產品編號及生產編號

與我們聯絡時，請提供完整的產品編號（E no.）和生產編號（FD no.），以便服務人員提供正確的建議。您可在爐具底部找到附有這些數字的銘牌。



您也可以在下方空位中記下爐具編號和售後服務中心的電話號碼，省卻尋找時間。

E no.

FD no.

After-sales service ☎

請注意，即使在保固期內，若因誤用本爐具而使註冊氣體裝置技工到府服務，則仍需收費。

您可以在隨附的清單中，找到各國售後服務中心的聯絡資料。

預約工程師上門並提供產品建議

HK 2553 8353

請相信製造商的專業，放心將家居爐具的維修工作交由註冊氣體裝置技工處理，並使用原廠零件。

Gaggenau Hausgerate GmbH

Carl-Wery-StraBe 34

81739 Munchen

GERMANY

www.gaggenau.com

GAGGENAU

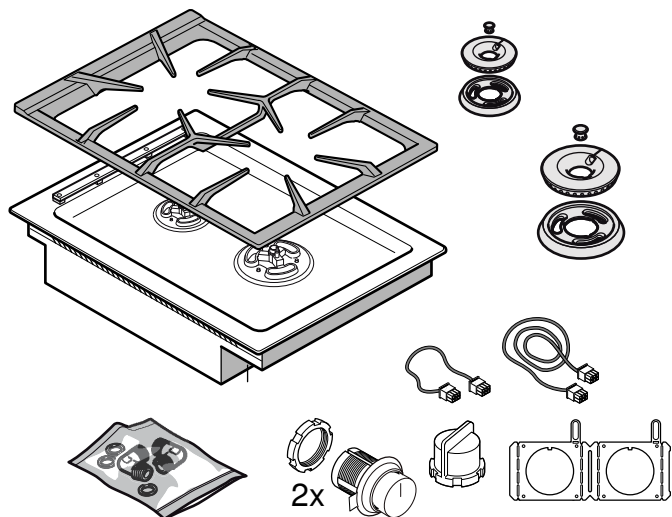

1a

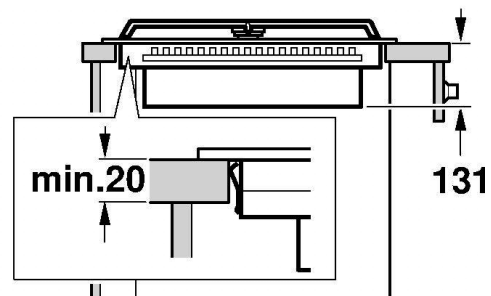
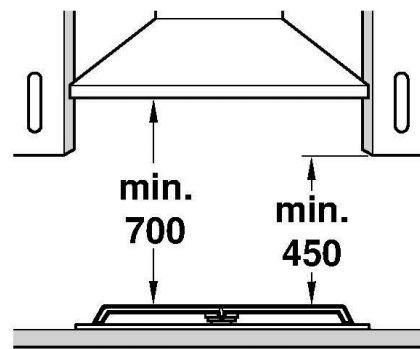
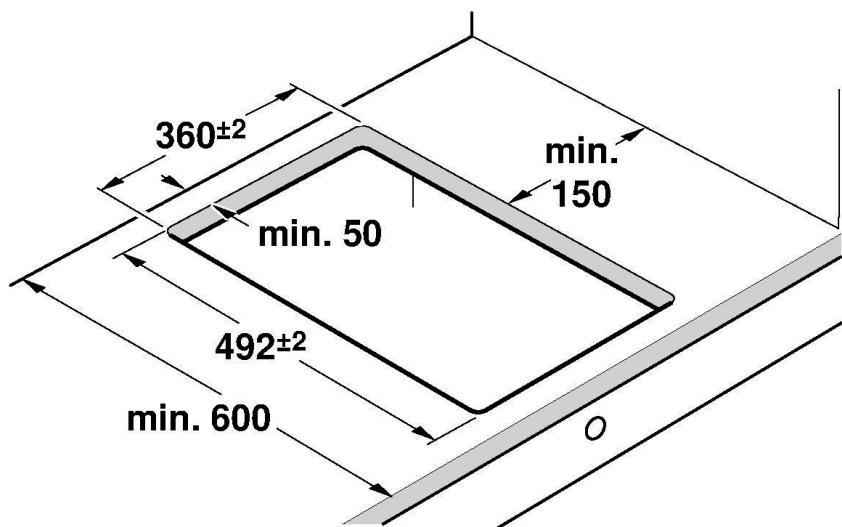
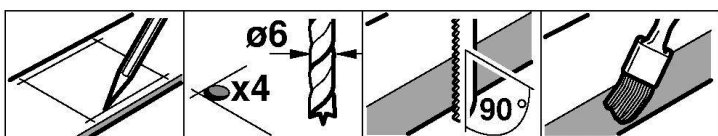

1b

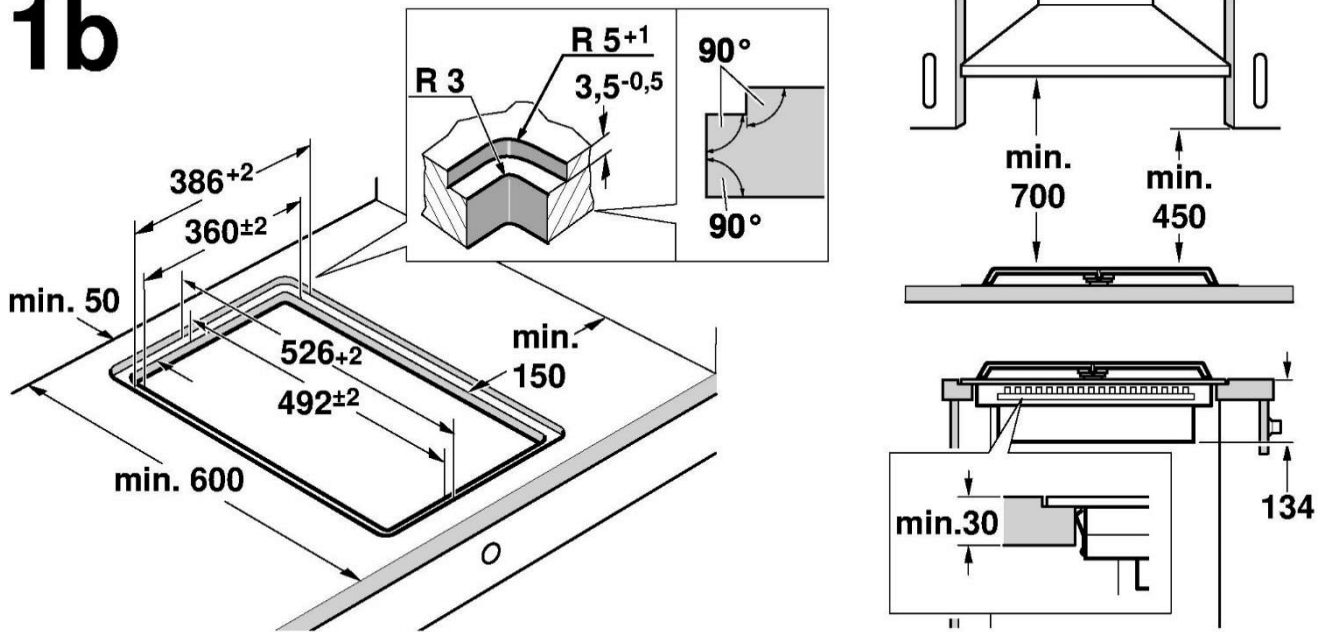

1c

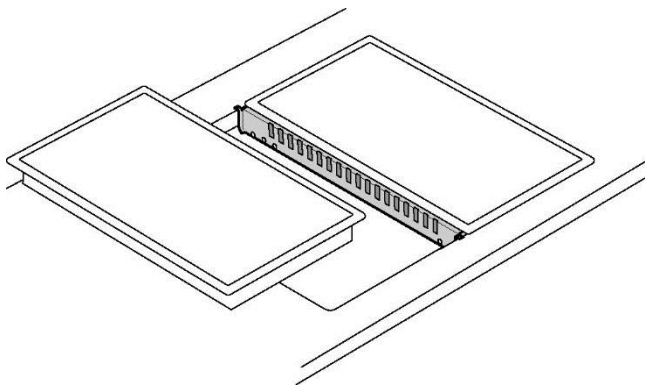

VA 420 000/001/010/011

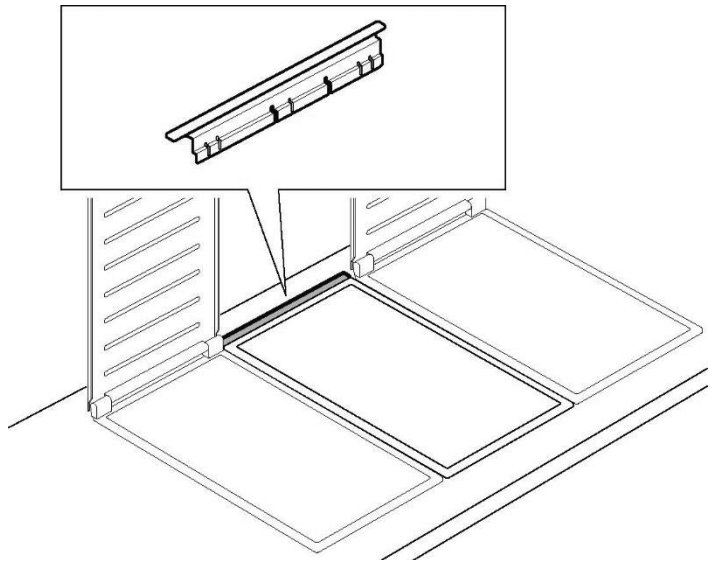

VA 450 110/-401/-600/-800/-900

1d

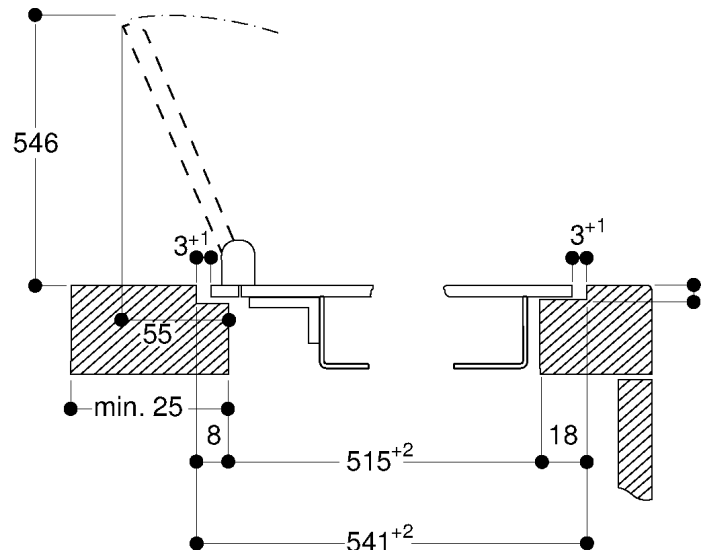
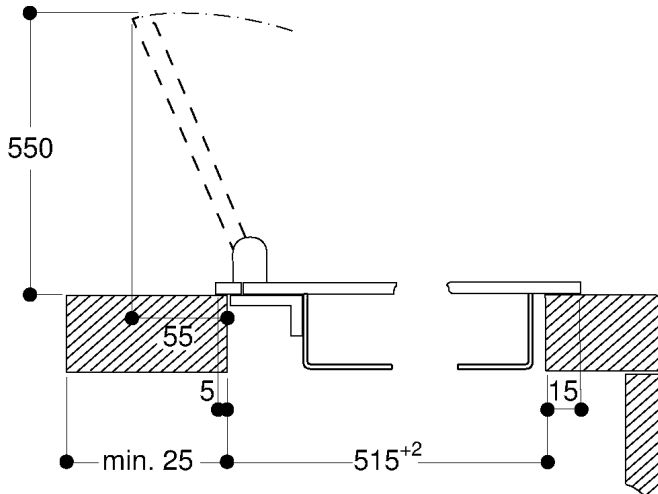

2

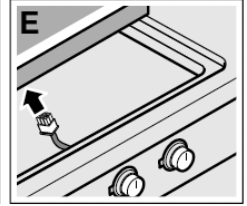
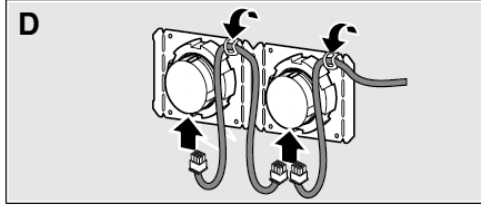
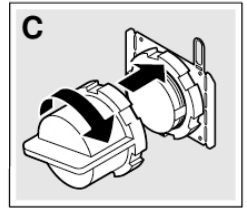
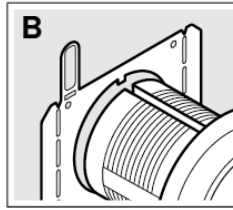
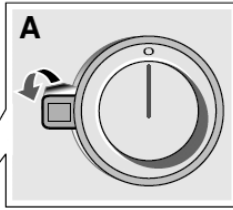
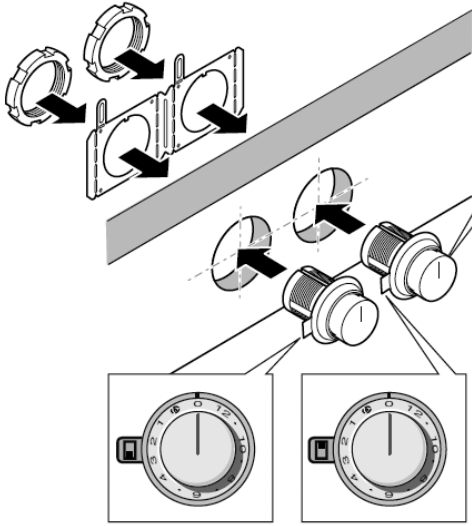

3a

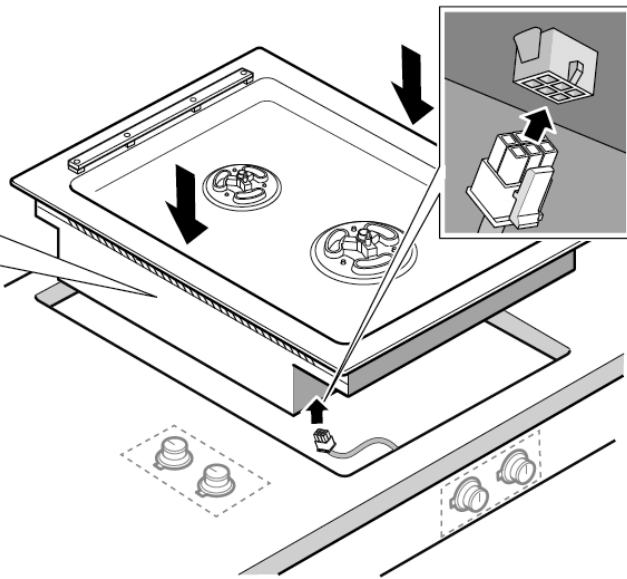
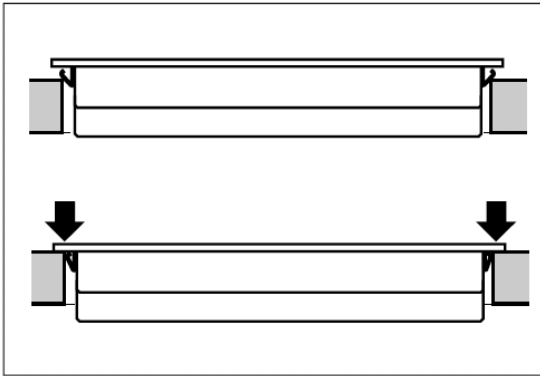

3b

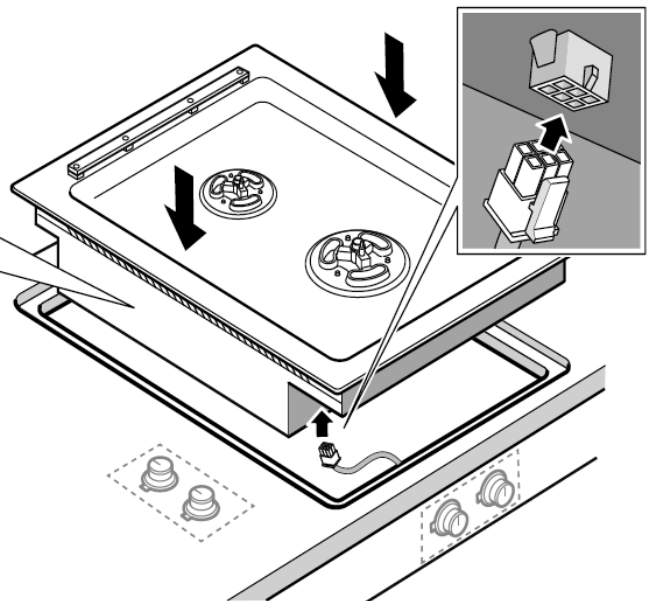
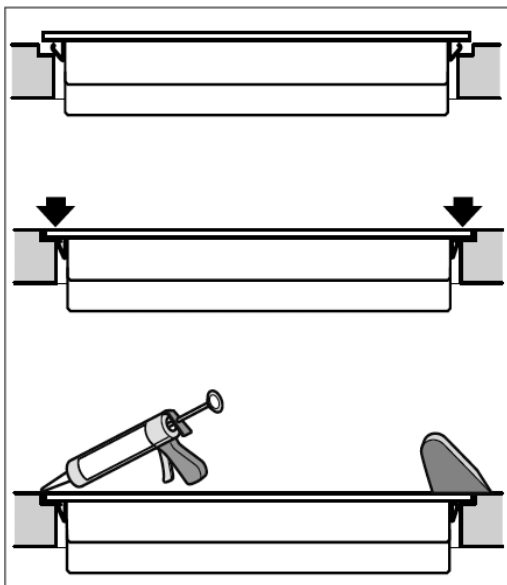

3c

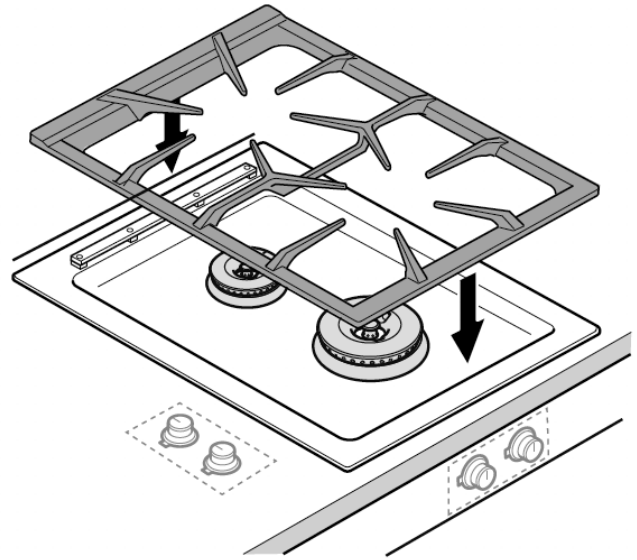
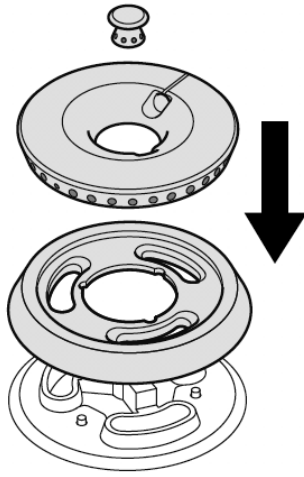



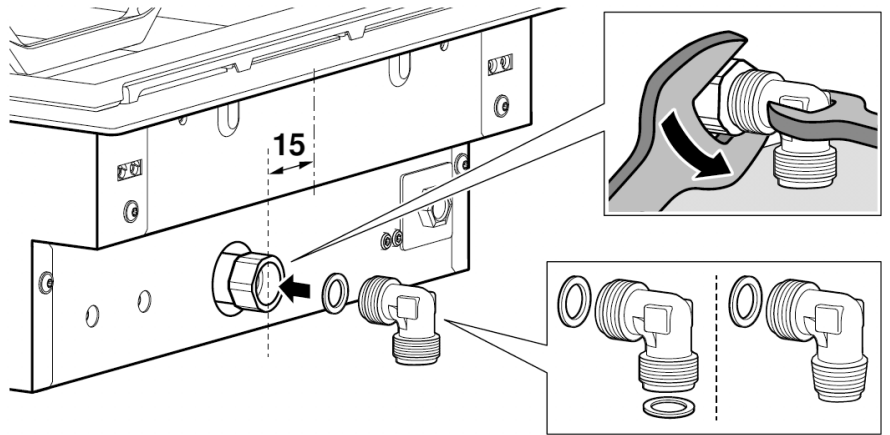
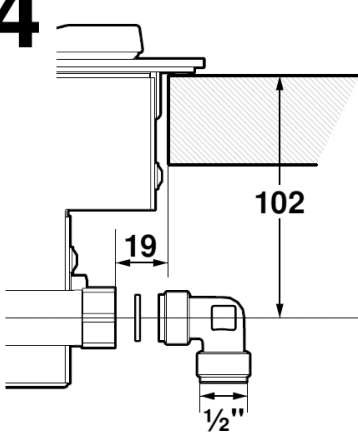

4

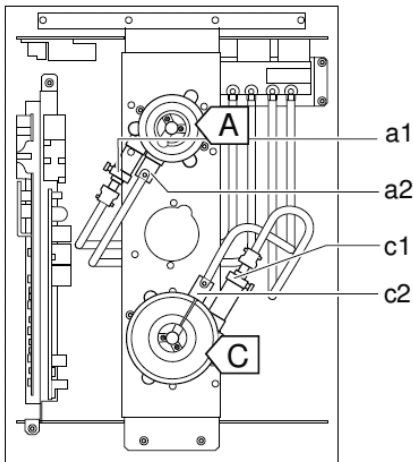

5



		煤氣 (香港) Town Gas (HK) 15 mbar
	A a1 L1	168 0 mm
	a2 L2	67 4 mm
		2.2 kW
		煤氣 (香港) Town Gas (HK) 15 mbar
	C c1 L1	332 0 mm
	c2 L2	67 4 mm
		4.5 kW

Important notes

Read these instructions carefully and keep them in a safe place. Safety during use can only be ensured if the appliance is fitted correctly according to these installation instructions. The installer is responsible for ensuring that the appliance operates perfectly at the point of installation.

Attention!

According to the Gas Safety Ordinance of Hong Kong, any gas installation works including the installation of appliances and connection tubing, must be undertaken by registered gas installers who are registered for that appropriate classes and be employed by registered gas contractors.

Use approved gas tubing bearing EMSD approval marking (example: 機電工程署批准 EMSD APPROVAL GTXXXX) for connection to appliances or other appropriate methods accepted by EMSD.

Appliance must not be converted to another type of gas.

Before carrying out any type of work, turn off the electricity and gas supply.

For installation, currently applicable building regulations and the regulations of local electricity and gas suppliers must be observed. The operating pressure of this gas hob is 15 mbar. Therefore no external gas governor is required.

⚠ Risk of gas escape!

After connecting the appliance to the gas supply, always check the connection for leak tightness. The manufacturer accepts no responsibility for the escape of gas from a gas connection which has been previously tampered with.

Ensure sufficient air exchange in the room where the appliance is installed. Up to 11 kW total input:

- Minimum volume of the room where appliance is installed: 20 m³
- A door leading to the open air or a window which can be opened.

Up to 18 kW total input:

- Minimum volume of the room where appliance is installed: 2 m³ per kW total input.
- A door leading to the open air or a window which can be opened.
- An extraction hood into the open air. Minimum displacement volume of extraction hood: 15 m³/h per kW total input.

The installation system must incorporate an all-pin isolating switch with a contact opening of at least 3 mm, or the appliance should be connected to the mains via a safety plug. The plug must remain accessible after installation is complete.

Specifications on the rating plate showing voltage, type of gas and gas pressure must agree with the local mains connection conditions. Do not kink or trap the mains connection cable.

This appliance corresponds to appliance class 3 (for installation in a kitchen unit). It must be fitted according to the installation drawing. The wall behind the appliance must be made of nonflammable material.

This appliance is not intended for operation with an external timer or an external remote control.

Do not install this appliance on boats or in vehicles.

Special accessories

You can order the following special accessories from your specialist dealer:

AA 414 010	Ventilation molding for operation next to downdraft ventilation VL 414
VA 420 000	Connection strip for combination with other Vario 400 appliances for flush installation
VA 420 001	Connection strip for combination with other Vario 400 appliances for flush installation with appliance cover/extension
VA 420 010	Connection strip for combination with other Vario 400 appliances for surface installation
VA 420 011	Connection strip for combination with other Vario 400 appliances for surface installation with appliance cover/extension
VA 440 010	Stainless steel appliance cover
VA 450 401	Appliance extension, 38 cm

Only use the accessories as specified. The manufacturer accepts no liability if these accessories are used incorrectly.

Preparing the units (Fig.1a)

The kitchen unit must be heat-resistant to at least 90°C (about 190°F). The stability of the unit must be maintained after producing the cut-out.

Produce the cut-out in the worktop for one or more Vario appliances as shown in the installation sketch. The angle between the cut surface and the worktop must be 90°.

The cut edges at the sides must be flat to ensure a good fit of the retaining springs on the appliance. In laminated worktops, it may be necessary to fit strips at the sides of the cut-out.

Remove shavings after cutting. Seal cut surfaces for resistance to heat and so they are watertight.

Pay attention to a minimum gap of 10 mm from the underside of the appliance to kitchen units.

Use suitable base constructions to ensure load-carrying capacity and stability, especially in the case of thin worktops. Pay attention to the weight of the appliance, including any payload. Reinforcement material used must be resistant to heat and moisture.

Note: Wait until the appliance has been installed in the installation opening before checking that it is level.

Installation flush with surrounding surfaces (Fig. 1b)

It is possible to fit the appliance into a worktop such that it is flush with the worktop surface.

The appliance can be installed in the following temperature- and water-resistant worktops:

- Granite worktops
- Plastic worktops (e.g. Corian®)
- Solid wood worktops: Only on agreement with the worktop manufacturer (seal the cut-out edges)
- For other worktop materials, contact the worktop manufacturer about their use.

The appliance cannot be installed in compressed-wood worktops.

Note: All cut-outs in the worktop are to be carried out in a specialist workshop in accordance with the installation diagram. Each cut-out must be neat and precise as the cut edge is visible on the surface. Clean and degrease the cut-out edges with a suitable cleaning agent (follow the instructions from the silicone manufacturer).

Combining multiple Vario appliances (Fig.1c)

The connecting strip VA 420 000/001/010/011 is required in order to combine multiple Vario appliances. This can be ordered separately as an optional accessory. When making the cut-out, allow extra space for the connecting strip between the appliances (see installation instructions VA 420 000/001/010/011).

Appliances can also be fitted in their own individual cut-outs as long as at least 50 mm of material is left between the cut-outs.

To enable combination of appliances with and without an appliance cover, dimension differences can be balanced out by the extension VA 450 110/-401/-600/-800/-900 (depending on appliance width).

Combination with appliance cover (Fig.1d)

The appliance cover VA 440 010 is available separately as an optional accessory. Take the additional space required by the appliance cover into consideration when making the cut-out.

Hole for the control knob

Possible installation types:

- At the front of the floor cabinet
- In the worktop next to the appliance
- In the worktop in front of the appliance

Note: Follow the installation instructions provided for the control knobs.

Fitting the control knobs (Fig.2)

Note: Follow the installation instructions provided for the control knobs.

1. Depending on the distance between the control knobs, it may be necessary to break off the retaining plate at the perforation. Hold the retaining plate in place against the rear of the control panel/ underside of the worktop or secure it in place with the screws provided.
2. When fitting an individual control knob or if the retaining plate has been broken off at the perforation, use two screws to hold each retaining plate in place and prevent it from rotating. For stone worktops, use temperature-resistant two-component adhesive (for metal to stone) to adhere the retaining plate.
3. Remove the protective film on the back of the illuminated ring.
4. Push the control knob into the hole, and use the installation

5. tool provided to tighten the nut at the rear.
6. Use the short cables provided to connect all the control knobs. The male connectors must snap into place in the female connectors.
Note: The two female cable connectors on the control knob are identical.
7. Attach the long cable to one of the control knobs to connect it to the appliance. The male connector must snap into place in the female connector.
Note: The appliance can be connected to any control knob.
8. After fitting, check that all plug-in connections are seated correctly.
9. After fitting all the cables, secure them to the retaining plate by turning the tab down.

appliance from below.

Caution!

Damage to appliance! Do not lever out the appliance from above.

Installing the appliance (Fig.3a)

1. Insert the end of the connection cable for the control knob into the female connector on the underside of the appliance. The male connector must snap into place.
2. Insert the appliance evenly into the cut-out. Push it down firmly into the cut-out.
Note: The appliance must sit fast in the cut-out and must not be able to move around (e.g. during cleaning). If the width of the cut-out is at the upper tolerance limit, secure batten to the sides of the cut-out if necessary.
3. Connect the appliance to the power and gas supply and test for correct functioning. There might be an air pocket in the gas supply line if the appliance switches off. Turn control knobs off and switch on again. Repeat until burner ignites.

Only for installation flush with surrounding surfaces (Fig.3b)

Note: Make sure that everything is working correctly before grouting. Grout the surrounding gap with a suitable temperature-resistant silicone adhesive (e.g. OTTOSEAL® S 70). Smooth the seal joint with a smoother recommended by the manufacturer. Follow the instructions for the silicone adhesive. Do not use the appliance until the silicone adhesive is completely dry (at least 24 hours, depending on the room temperature).

Caution!

Using unsuitable silicone adhesive on natural stone work surfaces may cause permanent discolouration.

Gas connection (Fig.4)

The gas connection must be located in a position where the stop tap is accessible.

According to the Gas Safety Ordinance of Hong Kong, any gas installation works including the installation of appliances and connection tubing, must be undertaken by registered gas installers who are registered for that appropriate classes and be employed by registered gas contractors.

Use approved gas tubing bearing EMSD approval marking (example: 機電工程署批准 EMSD APPROVAL GTXXXX) for connection to appliances or other appropriate methods accepted by EMSD.

Using R $\frac{1}{2}$ " (for appliance side) connection elbows provided, connect the appliance to the gas tubing. The gas tubing must be routed so that it does not come into contact with moving parts of the kitchen unit (e.g. drawers).

Electrical connection

Check that the appliance has the same voltage and frequency as the electrical installation system.

The hob is delivered with a mains cable, with or without plug, depending on model.

Only connect the appliance to sockets which have been fitted and earthed according to regulations.

The appliance corresponds to type Y: the mains connection cable must only be replaced by the after-sales service. Check the cable type and minimum cross section.

Technical data

Gas type: Hong Kong Town Gas (15 mbar)
Total connected load VG425311SG: 6.7 kW
Voltage and frequency: 220-240 V, 50/60 Hz
Electrical nominal power: 25 W

Removing the appliance

Disconnect the appliance from the power and the gas supply. For flush-mounted appliances, remove the silicone joint. Push out the

重要注意事項

請詳讀這些指示，並保存在安全之處。只有在依照安裝指示正確安裝爐具，才能確保使用時安全無虞。安裝者須負責確保爐具在安裝位置運作正常。

注意！

根據香港氣體安全條例，任何氣體裝置工程，包括爐具和接駁喉管的安裝，必須由註冊氣體裝置技工執行，而該技工已於相關的氣體工程類別註冊及受聘於註冊氣體工程承辦商。

使用認可印有機電工程署批准標記（例如：機電工程署批准EMSD APPROVAL GTXXX）的氣體接駁喉管連接爐具，或使用機電工程署接納的其他恰當方法。

切勿轉用其他氣體。

在進行任何工作之前請先關閉電源及煤氣供給。

安裝時，請遵守適用之建築條例以及當地電力及煤氣公司的相關規定。

這個氣體爐的操作壓力為15毫巴，因此不需要安裝外置氣體穩壓器。

⚠ 煤氣外洩風險！

請確保爐具安裝環境的通風條件。最大總熱負荷：11kW

- 爐具安裝處室內最小空間為：20 m³
- 通向室外可以打開的門或窗戶。

最大總熱負荷：18kW

- 爐具安裝處室內最小空間為：每千瓦總熱負荷2 m³。
- 通向室外可以打開的門或窗戶。

- 通往室外的抽油煙機。抽油煙機最小排量：每千瓦總熱負荷15 m³/h

安裝系統必須備有一個全極隔離開關，且接觸距離至少間隔3 mm，或是利用安全插頭將本爐具連接到主電源。安裝完成後必須仍能使用此插頭。

額定銘牌上的電壓資料、煤氣類型與煤氣壓力必須符合當地主電源連接條件。

請勿彎曲或卡住主電源連接線。

本爐具符合爐具等級3（適合安裝在廚房櫥櫃）。務必根據安裝圖示進行安裝。在爐具後方的壁面必需為不可燃材質。

本爐具不適合與外部計時器或遙控操作搭配使用。

請不要將本爐具安裝在船隻或運輸工具上。

特殊配件

可向專業零售商購買以下的特殊配件。

AA 414 010 用於下置型氣流通風爐具 VL414 旁邊的通風

VA 420 000 用來組合其他 Vario 400 爐具以進行齊平安裝的連接條

VA 420 00 用來組合其他 Vario 400 爐具以和爐具護蓋/延長線進行齊平安裝的連接條

VA 420 010 用來組合其他 Vario 400 爐具以進行表面安裝的連接條

VA 420 011 用來組合其他 Vario 400 爐具以和爐具護蓋/延長線進行表面安裝的連接條

VA 440 010 不銹鋼爐具的護蓋

VA 450 401 爐具延長線，38 cm

請勿使用指定配件以外的物品。若這些配件使用不正確，製造商將不對此負起任何責任。

準備安裝櫥櫃（圖1a）

廚房櫥櫃的耐熱度必須達到90°C（約190°F）。裁切作業完成後，必須確保櫥櫃仍為安全穩固。

按照安裝圖，為一或多個Vario爐具在工作檯上進行裁切作業。切口表面與工作檯之間的角度必須為90°。

側邊必須平坦，確保能安裝至爐具的固定彈簧。如果在夾板工作檯，可能會需要在切口的側面加上邊條。

切割完成後，請清理所有碎屑。把所有切割表面密封以達成耐熱與防水效果。

請注意爐具與廚房櫥櫃內側必須要有10mm的距離。

請使用合適的基底以確保承重份量以及穩定性，尤其是安裝在薄工作檯時。請注意爐具重量包含任何淨載重量。加固所使用的材料必須有

耐熱和防潮功能。

提示：請先將爐具安裝至開口，再檢查是否水平。

以週圍表面齊平的方式進行安裝（圖1b）

可以將爐具安裝至工作檯，讓爐具與工作檯表面齊平。

此爐具可以安裝於下列耐熱與防水工作檯：

- 花崗石工作檯
- 塑膠工作檯（例如：可麗耐®）
- 實心木頭工作檯：應遵循工作檯製造商的要求（密封切割邊緣）
- 關於其他工作檯材質的處理方式，請洽詢製造商。

請勿將爐具安裝至壓縮木工作檯。

提示：工作檯上的所有切口都必須在專業工場中進行，如安裝圖所示。由於切邊在表面上可見，每個切口必須整齊且精確。請用適當的清潔劑來清潔切口邊緣與清除髒污（請依照矽膠製造商的說明）。

組合多個Vario爐具（圖1c）

組合Vario爐具需使用VA 420 000/001/010/011連接條。可另外選購此配件。進行裁切作業時，請在爐具與連接條之間保留空間（請參閱安裝說明 VA 420 000/001/010/011）。

還可以將爐具分別安裝在各個裁切開口內，但各開口之間要保留至少50 mm的寬度。

組裝時可使用延長線VA 450 110/-401/-600/-800/-900（依爐具寬度）來彌補使用或不使用爐具護蓋的尺寸差異。

組合爐具蓋（圖1d）

可以將爐具蓋VA 440 010作為特殊附件訂購。製作裁切開口時，請考慮爐具蓋所需的額外空間。

控制旋鈕的洞

可能的安裝類型：

- 落地櫃前方
- 相鄰爐具的工作檯上
- 爐具前的工作檯上

提示：根據安裝說明書安裝控制旋鈕。

安裝控制旋鈕（圖2）

提示：根據安裝說明書安裝控制旋鈕。

1. 視控制旋鈕之間的距離，進行切割作業時可卸下固定板。將固定板靠在控制面板的後部/工作檯的下側，或者用隨附的螺絲固定到位置。
2. 當安裝單獨控制旋鈕或如果固定板在穿孔處斷裂時，請使用兩顆螺絲來保持固定板並防止其轉動。將爐具安裝在石面工作檯的固定板時，請使用耐高溫二液性黏劑（限金屬至石面）。
3. 撕開發光圓環後方的保護膜。
4. 將控制旋鈕推入孔中，並使用隨附的安裝輔助工具鎖緊後部的螺帽。
5. 使用隨附的短電線連接所有控制旋鈕。公接頭必須插入母接頭的正確位置。
提示：控制旋鈕的兩條母電源連接線路相同。
6. 將長電線連接到其中一個控制旋鈕以將其連接到爐具。公接頭必須插入母接頭的正確位置。
提示：本爐具可以連接至任何的 control 旋鈕。
7. 安裝完畢後，請確認是否正確安裝所有插座線路。
8. 安裝所有的電源線路後，轉動卡口固定其固定板。

安裝爐具（圖3a）

1. 將控制旋鈕連接電線的一端插入爐具底部的母接頭中。公接頭必須插入正確位置。
2. 把爐具平整地放入切割的部份中。向下推壓以穩固地推入切割的部份。
提示：必須把設備穩固地放置入切割部份中，並請勿將之移動（例如在清潔時）。如果裁切部份的闊度達到了可容納範圍的上限，如有需要請在裁切部份的兩側加上邊條。
3. 將爐具連接至電源與煤氣供給，檢查是否能正常運作。如果爐具關閉，可能表示煤氣供給管路中有氣穴。轉動並關閉控制旋鈕，然後再次打開。重複動作直到爐頭火。

只限齊平安裝（圖3b）

提示：在進行填充前，請先確定所有部件都能正確運作。

在間隙的周圍填充適當的耐熱矽膠（例如 OTTOSEAL® S70）。請使用製造商建議的拋光劑使密封接頭光滑。請遵照矽膠黏著劑的使用說明操作。在矽膠黏著劑完全乾燥之前，請勿使用爐具（至少 24小時，因室溫而異）。

注意！

使用不適當的矽膠黏著劑可能會導致天然大理石工作檯出現永久性變色。

煤氣連接（圖4）

供氣連接必須置於在關閉閘門可接近的位置。

根據香港氣體安全條例，任何氣體裝置工程，包括爐具和接駁軟喉的安裝，必須由註冊氣體裝置技工執行，而該技工已於相關的氣體工程類別註冊和受聘於註冊氣體工程承辦商。

使用認可印有機電工程署批准標記（例如：機電工程署批准EMSD APPROVAL GTXXXX）的氣體接駁軟喉連接爐具，或使用機電工程署接納的其他恰當方法。

使用一個R $\frac{1}{2}$ "（燃氣灶側）彎接頭，使氣體爐連接至接駁軟喉。接駁軟喉鋪設必須避免與廚房設備的活動零件相接觸（例如，抽屜）。

電源連接

檢查爐具是否與電氣安裝系統有相同的電壓及頻率。

爐頭隨附主電源線，但是否附有插頭依型號而定。

僅能將爐具插入符合安裝與接地規定的插座。

Y型爐具：僅能透過售後服務中心更換主電源連接線。檢查電纜種類及最小橫截面

技術規格

氣種：香港煤氣（15毫巴）

總連接載量 VG425311SG: 6.7 kW

電壓及頻率: 220-240V, 50/60 Hz

電力額定功率: 25 W

拆除爐具

斷開爐具的電源與煤氣供給。若為齊平式爐具，請移除矽膠接頭。

從下面將爐具向上推。

注意！

爐具損壞！請勿從上方將爐具撬開。

Gaggenau Hausgeräte GmbH
Carl-Wery-Straße 34
81739 München
GERMANY
www.gaggenau.com

9001154509 (980328)
en, zh-hk



GAGGENAU