

CE291...

Glass ceramic cooktop

CE291...

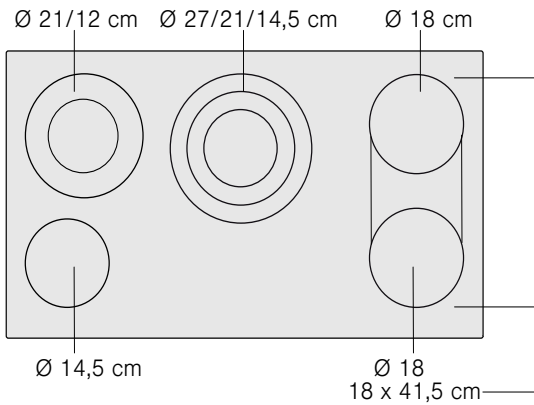

Table of contents

Intended use	3
Important safety information	3
Causes of damage	4
Overview	4
Environmental protection	4
Environmentally-friendly disposal	4
Energy-saving tips	4
Getting to know your appliance	5
The control panel	5
The hotplates	5
Residual heat indicator	5
Setting the hob	6
Switching the cooktop on and off	6
Setting a hotplate	6
Settings table	7
PowerBoost	8
Switching on PowerBoost	8
Switching off PowerBoost	8
Frying sensor function	8
Pans for the sensor frying system	8
The frying settings	8
Setting the frying sensor function	9
Switching off the frying sensor function	9
Frying table	10
Childproof lock	11
Switching the child safety lock on and off	11
Automatic childproof lock	11
Timer	11
Automatic hotplate switch-off	11

Automatic timer	11
Kitchen timer	12
Safety shut-off	12
Wipe protection	12
Options menu	13
Selecting the options menu	14
Cleaning and care	14
Ceramic	14
Hob surround	14
Rectifying faults	15
After-sales service	15

Additional information on products, accessories, replacement parts and services can be found at www.gaggenau.com and in the online shop www.gaggenau.com/zz/store

⚠ Intended use

Read these instructions carefully. Please keep the instruction and installation manual, as well as the appliance certificate, in a safe place for later use or for subsequent owners.

Check the appliance for damage after unpacking it. Do not connect the appliance if it has been damaged in transport.

Only a licensed professional may connect appliances without plugs. Damage caused by incorrect connection is not covered under warranty.

This appliance is intended for private domestic use and the household environment only. The appliance must only be used for the preparation of food and beverages. The cooking process must be supervised. A short cooking process must be supervised without interruption. Only use the appliance in enclosed spaces.

This appliance is intended for use up to a maximum height of 2000 metres above sea level.

This appliance may be used by children over the age of 8 years old and by persons with reduced physical, sensory or mental capabilities or by persons with a lack of experience or knowledge if they are supervised or are instructed by a person responsible for their safety how to use the appliance safely and have understood the associated hazards.

Children must not play with, on, or around the appliance. Children must not clean the appliance or carry out general maintenance unless they are at least 15 years old and are being supervised.

Keep children below the age of 8 years old at a safe distance from the appliance and power cable.

⚠ Important safety information

Risk of fire!

- Hot oil and fat can ignite very quickly. Never leave hot fat or oil unattended. Never use water to put out burning oil or fat. Switch off the hotplate. Extinguish flames carefully using a lid, fire blanket or something similar.
- The hotplates become very hot. Never place combustible items on the hob. Never place objects on the hob.
- The appliance gets hot. Do not keep combustible objects or aerosol cans in drawers directly underneath the hob.
- The hob switches off automatically and can no longer be operated. It may switch on unintentionally at a later point. Switch off the circuit breaker in the fuse box. Contact the after-sales service.
- Do not use hob covers here. They can cause accidents, for example due to overheating, catching fire or materials shattering.

Risk of burns!

- The hotplates and surrounding area (particularly the hob surround, if fitted) become very hot. Never touch the hot surfaces. Keep children at a safe distance.
- The hotplate heats up but the display does not work. Switch off the circuit breaker in the fuse box. Contact the after-sales service.
- It is only allowed to use safety devices, e.g. hob guards, which have been approved by ourselves. Unsuitable safety devices or hob guards may result in accidents.

Risk of electric shock!

- Incorrect repairs are dangerous. Repairs may only be carried out and damaged power cables replaced by one of our trained after-sales technicians. If the appliance is defective, unplug the appliance from the mains or switch off the circuit breaker in the fuse box. Contact the after-sales service.
- Do not use any high-pressure cleaners or steam cleaners, which can result in an electric shock.

- A defective appliance may cause electric shock. Never switch on a defective appliance. Unplug the appliance from the mains or switch off the circuit breaker in the fuse box. Contact the after-sales service.
- Cracks or fractures in the glass ceramic may cause electric shocks. Switch off the circuit breaker in the fuse box. Contact the after-sales service.

Risk of injury!

Saucepans may suddenly jump due to liquid between the pan base and the hotplate. Always keep the hotplate and saucepan bases dry.

Causes of damage

Caution!

- Rough pot and pan bases scratch the ceramic.
- Avoid boiling pots dry. This may cause damage.
- Never place hot pots or pans on the control panel, the display area or the surround. This may cause damage.
- Damage can occur if hard or pointed objects fall on the hob.
- Aluminium foil and plastic containers melt on hot hotplates. Oven protective foil is not suitable for your hob.

Overview

You will find the most frequently caused damage in the following table.

Damage	Cause	Measure
Stains	Boiled over food	Remove boiled over food immediately with a glass scraper.
	Unsuitable cleaning agents	Only use cleaning agents that are suitable for glass ceramic.
Scratches	Salt, sugar and sand	Do not use the hob as a work surface or storage space.
	Rough pot and pan bases scratch the ceramic.	Check your cookware.

Damage	Cause	Measure
Discolouration	Unsuitable cleaning agents	Only use cleaning agents that are suitable for glass ceramic.
	Pan abrasion (e.g. aluminium)	Lift pots and pans when moving them.
Blisters	Sugar, food with a high sugar content	Remove boiled over food immediately with a glass scraper.

Environmental protection

Environmentally-friendly disposal

Dispose of packaging in an environmentally-friendly manner.



This appliance is labelled in accordance with European Directive 2012/19/EU concerning used electrical and electronic appliances (waste electrical and electronic equipment - WEEE). The guideline determines the framework for the return and recycling of used appliances as applicable throughout the EU.

Energy-saving tips

- Always place suitable lids on saucepans. When cooking without a lid, considerably more energy is required. A glass lid means that you can see inside without having to lift the lid.
- Use pots and pans with even bases. Uneven bases increase energy consumption.
- The diameter of pot and pan bases should be the same size as the hotplate. In particular, small saucepans on the hotplate cause energy losses. Please note: cookware manufacturers often indicate the upper diameter of the saucepan. This is usually bigger than the diameter of the base of the pan.
- Use a small saucepan for small quantities. A larger, less full saucepan requires a lot of energy.
- Cook with only a little water. This will save energy. Vitamins and minerals in vegetables are preserved.
- Always cover as large an area of the hotplate as possible with your saucepan.
- Switch to a lower heat setting in good time.
- Select a suitable ongoing cooking setting. You will waste energy by using an ongoing cooking setting which is too high.
- Use the residual heat of the hob. For longer cooking times, you can switch the hotplate off 5-10 minutes before the end of the cooking time.

Getting to know your appliance

The instruction manual is the same for various different hobs. An overview of the models with their dimensions is given on page 2.

The control panel

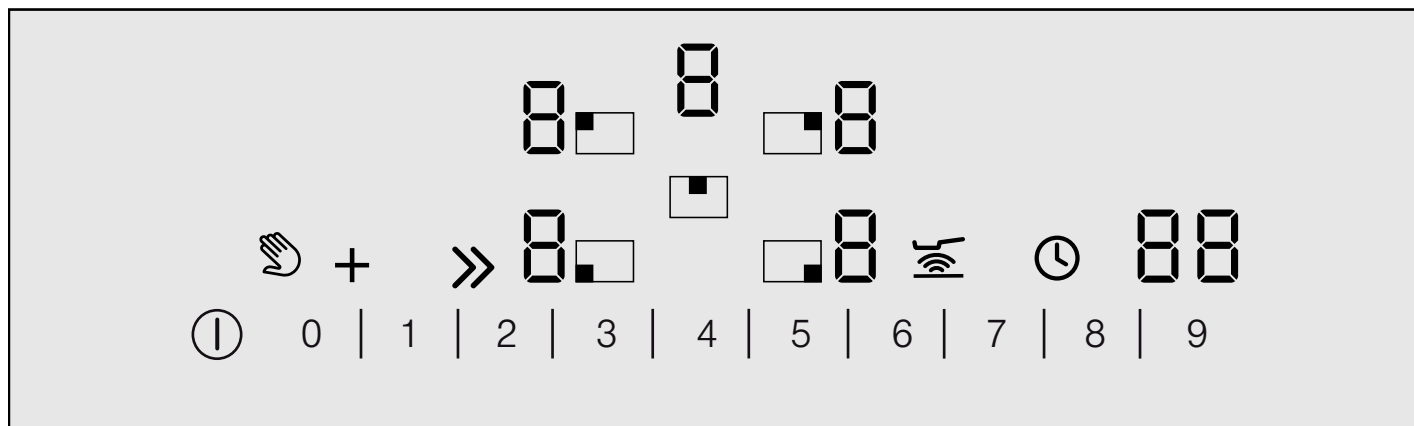

Displays

1-9 Heat settings

H/h Residual heat

b PowerBoost function

88 Timer

Controls

① Primary switch

Hand icon Control panel pause / Childproof lock

⊕ Automatic zone control

⊹ PowerBoost function

□ Hotplate selection

1|2|3|4| Control panel

Wave icon Sensor frying system

⌚ Timer

Notes

- When you touch a symbol, the respective function is activated.
- Always keep the controls dry. Moisture reduces their effectiveness.
- Do not pull pans close to the displays and sensors. The electronics could overheat.

The hotplates

Hotplate	Activating and deactivating
<input type="radio"/> Single-circuit hotplate	
<input checked="" type="radio"/> Dual-circuit hotplate	Select the hotplate and touch the + symbol
<input checked="" type="radio"/> Tri-circuit hotplate	Select the hotplate, touch the + symbol; the 2nd filament circuit is activated Touch the + symbol again; the 3rd filament circuit is activated
<input type="radio"/> Roaster hotplate	Select one of the two roaster hotplates, touch the symbol + ; the 2nd hotplate and roaster are activated.

Activating the hotplate: the corresponding indicator lights up.

Residual heat indicator

The hob has a two-stage residual heat indicator for each hotplate.

If *H* appears in the display the hob is still hot. It may be used, for example, to keep a small meal warm or to melt cooking chocolate. As the hotplate cools down further, the display changes to *h*. The display remains lit until the hotplate has cooled sufficiently.

Setting the hob

This section informs you how to set the hotplates. The table shows heat settings and cooking times for various meals.

Switching the cooktop on and off

The main switch is used to switch the cooktop on and off.

Switching on

Touch the symbol ①. An audible signal sounds. The indicator light above the main switch and the  indicators light up. The cooktop is ready to use.

Switching off

Touch the symbol ① until the indicator light above the main switch and the indicators go out. All hotplates are switched off. The residual heat indicator remains on until the hotplates have cooled down sufficiently

Notes

- The hob will switch itself off automatically once all hotplates have been switched off for a while (10-60 seconds).
- The settings remain stored for 4 seconds after the cooktop has been switched off. If you switch it on again during this time, the cooktop will operate using the previously stored settings.

Setting a hotplate

Set the required heat setting in the settings range.



Heat setting 1 = Lowest power

Heat setting 9 = Highest power

Every heat setting has an intermediate setting. This is identified by a dot.

Setting the heat setting

The cooktop must be on.

- 1 Touch the  symbol to select the hotplate.  lights up in the heat setting indicator,  lights up under the heat setting indicator.
- 2 Set the required heat setting in the settings range.

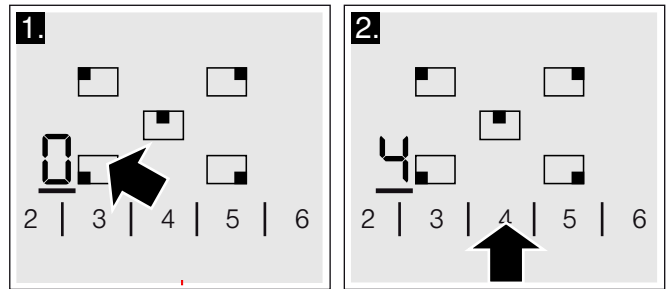

The hotplate is switched on.

Changing the heat setting

Select the hotplate and set the required heat setting in the settings range.

Switching off the hotplate

Use the  symbol to select the hotplate. Set the settings range to 0. After about 10 seconds, the residual heat indicator appears.

Note: The last selected hotplate remains activated. You can set the hotplate without selecting it again.

Settings table

Each cooking zone has 9 settings and intermediate settings. To quickly reach the required temperature, use the quick boil timer or use heat setting 9. You must then always switch back to the required heat setting.

The values in the settings table must only be used as a guideline because more or less heat is required depending on the type and state of the food as well as the size of the pan and how full it is.

The settings areas are the same for all cooking zones.

Heat setting	Cooking methods	Examples
9	Bringing to the boil	Water
	Searing	Meat
	Heating	Fat, liquids
	Bringing to the boil	Soups, sauces
9 - 8	Blanching	Vegetables
8 - 6	Roasting	Meat, potatoes
6 - 5	Roasting	Fish
7 - 6	Baking	Dishes made with flour, egg-based dishes
	Ongoing cooking in open container	Pasta, liquids
6 - 5	Browning	Flour, onions
	Toasting	Almonds, bread crumbs
	Rendering	Bacon
	Reducing	Stock, gravy
5 - 4	Simmering in open container	Dumplings, soup garnishes, boiling meat, poached eggs
4 - 3	Simmering in open container	Cooked sausages
5 - 4	Steaming	Vegetables, potatoes, fish
	Steam	Vegetables, fruit, fish
	Braising	Roulades, roasts, vegetables
3 - 2	Stewing	Goulash
4 - 3	Simmering with closed lid	Soups, sauces
3 - 2	Defrosting	Frozen food
3 - 2	Steeping	Rice, pulses
	Thickening	Egg-based dishes
2 - 1	Heating/keeping warm	Soups, stews, vegetables in sauces
	Melting	Butter, chocolate

PowerBoost

PowerBoost lets you heat up large volumes of water even faster than on heat setting 9.

PowerBoost is only available on cooking zones marked with the >> symbol.

With dual-circuit cooking zones, the second filament circuit has to be activated for use with PowerBoost.

Switching on PowerBoost

- 1 Select the hotplate.
- 2 Touch the >> symbol in the settings range. The **b** display will light up.

The PowerBoost function is switched on.

Switching off PowerBoost

- 1 Select the hotplate.
- 2 Select any ongoing cooking setting. The **b** display goes out.

The PowerBoost function is switched off.

Notes

- If you do not turn off the PowerBoost function, it switches off automatically after a certain period of time. The hotplate switches back to the heat setting 9.
- Please remember that oil and fat heat up quickly with PowerBoost. Never leave the hob unattended. Oil and fat that have overheated will catch fire quickly, see section Important safety information.

Frying sensor function

The tri-circuit hotplate features a frying sensor function. If you operate the hotplate with the frying sensor function, a sensor will regulate the temperature of the frying pan. The hotplate only heats up when necessary. This will save energy. Oil and fat do not overheat.

The 2nd filament circuit in the dual-circuit hotplate is activated when setting the frying sensor function.

Notes

- Never leave fat unattended while you are heating it.
- Place the frying pan on the centre of the cooking zone. Make sure that the base of the pan has the correct diameter.
- Do not place a lid on the pan, otherwise the regulator will not work. You can use a splatter guard.
- Select the 'min' frying setting if you are using olive oil. When using oils and fats which can be heated to high temperatures, e.g. refined plant oils or clarified butter, any frying setting can be used.

Pans for the sensor frying system

The pans suitable for this function can be purchased at a later date as special accessories from your dealer or from our customer service. Always include the following parts numbers:

GP900003 large container (21 cm)

The pan is non-stick. You can fry good without using much fat.

Note: The sensor frying system may also work with other pans. Test the pans first with low frying settings, changing as necessary. The pans may overheat on high frying settings.

The frying settings

Frying setting	Temperature	Suitable for
max	high	E.g. potato fritters, sautéed potatoes and rare (bloody) steaks
med	medium high	E.g. thin fried foods, such as escalopes, breaded frozen products, strips of meat, vegetables
low	low - medium	E.g. thick fried foods such as rissoles and sausages, fish
min	low	E.g. omelettes, food fried with butter, olive oil or margarine

Setting the frying sensor function

Select the appropriate frying setting from the table. Put the pan on the hotplate.

The hob must be switched on.

- 1 Touch the  symbol. The **A** in the display lights up. The possible frying settings appear in the display menu.

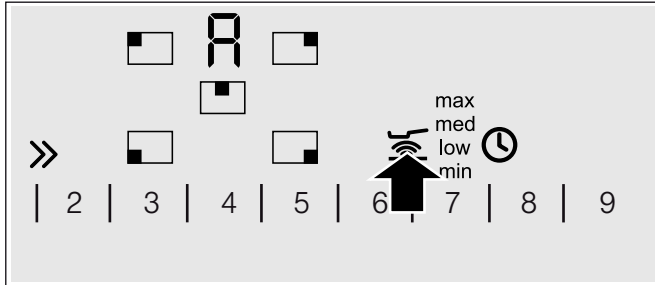

- 2 Within the next 10 seconds, select the required frying setting in the settings range:

min	Heat setting 2
low	Heat setting 4
med	Heat setting 6
max	Heat setting 8

The sensor frying system is activated. The 2nd filament circuit in the tri-circuit hotplate is automatically switched on.

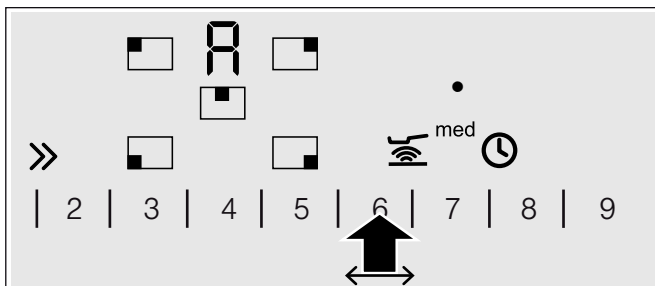

The symbol ● lights up until the frying temperature is reached. Then a signal sounds. The temperature symbol goes out.

- 3 Add the fat and then the food to the pan. Turn as you normally would to prevent burning.

Switching off the frying sensor function

Touch the  symbol.

Frying table

The table shows which frying setting is suitable for which dish. The frying time may depend on the type, weight, thickness and quality of the food.

The frying settings indicated are tailored to the Gaggenau frying sensor pan. The frying settings may vary if you use different pans.

		Frying setting	Total frying time after the signal sounds
Meat	Veal escalope, plain or breaded (1.5 cm thick)	med	6-10 min
	Fillet (pork, beef or veal), medium (2.5 cm thick)	med	6-10 min
	Cutlet (pork or lamb, 2 cm thick)	low	10-17 min
	Beef steak, rare (3 cm thick)	max	6-8 min
	Beef steak, medium or well done (3 cm thick)	med	8-12 min
	Saddle of lamb, medium (1.5 - 2.5 cm thick)	low	10-15 min
	Chicken breast (2 cm thick)	low	10-20 min
	Bratwurst sausage, boiled or raw (diameter 1-3 cm)	low	8-20 min
	Hamburgers/rissoles (1-3 cm thick)	low	6-30 min
	Strips of meat	med	7-12 min
	Minced meat	med	6-10 min
	Bacon rashers	min	5-8 min
Fish	Whole fish	low	15-25 min
	Fish fillet, plain or breaded	low/med	10-20 min
	Salmon steak (2.5 cm thick)	low	8-12 min
	Tuna steak, well done (2.5 cm thick)	low	8-12 min
	Scampi, prawns	med	4-8 min
	Scallops	med	5-8 min
Egg dishes	Pancakes, crêpes	med	continuous frying
	Omelettes	min	continuous frying
	Fried egg	min/med	2-6 min
	Scrambled egg	min	2-4 min
	French toast	low	continuous frying
Potatoes	Potatoes fried from unpeeled boiled potatoes	max	6-12 min
	Potatoes fried from raw*	low	15-25 min
	Potato fritter	max	continuous frying
	Rösti	min	30-40 min
	Glazed potatoes	med	10-15 min
Vegetables	Garlic, onions	min	2-10 min
	Courgettes, aubergines	low	4-12 min
	Peppers, green asparagus, carrots	low	4-15 min
	Mushrooms	med	10-15 min
	Glazed vegetables	med	6-10 min
Frozen products	Fish fillet, plain or breaded (0.5-1 cm thick)	low	10-20 min
	Stir fries/stir-fried vegetables	min	8-15 min
	Spring rolls (2.5-3 cm thick)	low	10-30 min
Miscellaneous	Rice, pasta	max	8-15 min
	Croutons	low	6-10 min
	Toasting almonds/other nuts/pine nuts*	min	3-7 min



* Place in the cold frying pan

Childproof lock

You can use the childproof lock to prevent children from switching on the hotplates.

Switching the child safety lock on and off

The hob must be switched off.

To switch on: Touch the  symbol for approx. 4 seconds. The  display lights up for 10 seconds. The hob is locked.

To switch off: Touch the  symbol for approx. 4 seconds. The lock is released.

Automatic childproof lock

This function automatically activates the childproof lock every time you switch the hob off.

Switching on and off

You can find out how to switch the automatic child safety lock on in the 'Options Menu' section.

Timer

The timer can be used in two different ways:



- To switch a hotplate off automatically
- As a kitchen timer

Automatic hotplate switch-off

Enter a cooking time for the relevant hotplate. When the cooking time has elapsed, the hotplate switches off automatically.

Setting the cooking time

The hotplate must be selected and set.

- 1 Touch the  symbol. The  display for the hotplate lights up.  lights up on the timer display.

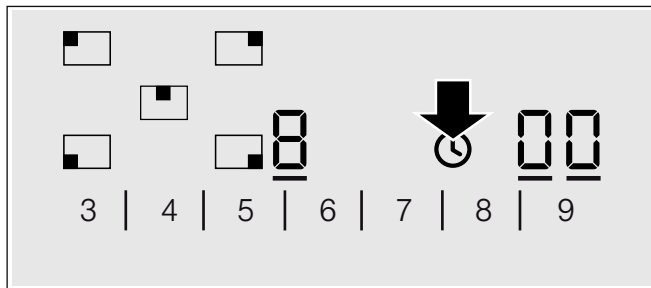

- 2 Within the next 10 seconds, set the desired cooking time on the control panel.

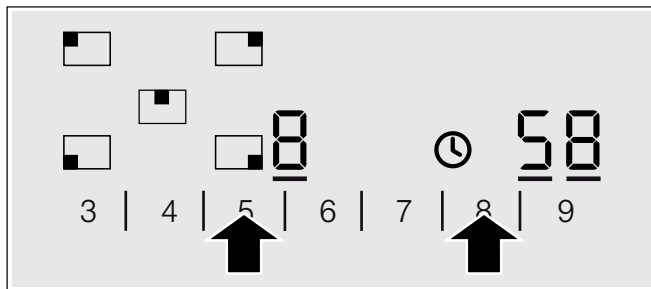



The cooking time counts down. If you have set a cooking time for more than one hotplate, the cooking time of the selected hotplate is always displayed.



Sensor frying system

When you cook with the sensor frying system, the set cooking time only begins when the temperature for the selected area is reached.

When the time has elapsed

When the cooking time has elapsed, the hotplate switches off. You will hear an audible signal and  lights up in the display for 10 seconds. The  display lights up brightly. Touch any symbol. The displays go out and the audible signal ceases.

Changing or cancelling the cooking time



Select the hotplate and touch the  symbol. The indicator  lights up brightly. Change the cooking time or set to  in the settings range.

Note: You can set a cooking time of up to 99 minutes.

Automatic timer

You can use this function to preselect a cooking time for all hotplates. Each time a hotplate is switched on, the pre-selected cooking time then counts down. When the cooking time has elapsed, the hotplate switches off automatically.

Find out how to switch on the automatic timer in the section Options Menu.



Note: You can change the cooking time for a hotplate or switch off the automatic timer for the hotplates: Select the hotplate and touch the  symbol. The required indicator  lights up brightly. Change the cooking time or set to  in the settings range.

Kitchen timer

You can use the kitchen timer to set a time of up to 99 minutes. It runs independently of all the other settings.

Switching on the kitchen timer

You can switch the kitchen timer on in 2 different ways:



- If a hotplate has been selected, touch the symbol  twice within 10 seconds.
- If a hotplate has not been selected, touch the  symbol.

The  indicator lights up.

Setting the kitchen timer

Set the required time in the settings range.

When the time has elapsed

After the time has elapsed, you will hear an audible signal.  lights up in the timer indicator. The indicator  for the kitchen timer lights up brightly. The indicator switches off after 10 seconds.

Displaying the time

Use the  symbol to select the kitchen timer. The time is displayed for 10 seconds.

Setting the correct time

Use the  symbol to select the kitchen timer and reset the time.

Safety shut-off

If a hotplate is switched on for a long time without the setting being changed, the automatic safety shut-off is activated.



The hotplate stops heating. *FB* and the *H/h* residual heat indicator flash alternately on the hotplate indicator.

The indicator goes out when you touch any control. You can implement new settings.

The point at which the safety shut-off becomes active (1 to 10 hours) depends on which heat setting has been set.

Wipe protection

If you wipe over the control panel while the cooktop is switched on, settings may be altered.

To prevent this from happening, your cooktop has a wipe protection function. Touch the  symbol. An audible signal sounds. The indicator light above the  symbol lights up. The control panel is locked for 30 seconds. You can now wipe over the control panel without altering any settings.

Note: The main switch is excluded from the wipe protection function. You can switch off the cooktop at any time.

Options menu

Your appliance has various basic settings. You can adjust these settings to meet your own needs.

Display	Function
c 1	Automatic child safety lock 0 Switched off.* 1 Switched on. 2 Manual and automatic child safety lock switched off.
c 2	Audible signal 0 The confirmation signal and operating error signal are switched off. 1 Only incorrect operation signal switched on. 2 Only confirmation signal switched on. 3 Confirmation signal and incorrect operation signal switched on.*
c 5	Automatic timer 0 Switched off.* 1-99 Cooking time after which the hotplates switch off
c 6	Duration of the timer end signal 1 10 seconds.* 2 30 seconds 3 1 minute.
c 7	Activation of the filament circuits 0 Switched off. 1 Switched on. 2 Last setting before the hotplate switched off.*
c 9	Time for selecting the hotplate 0 Unlimited: The last selected hotplate can always be adjusted without having to select it again.* 1 Once you select a hotplate, you have 10 seconds to adjust it, after which you will have to select it again in order to be able to adjust it.
c 0	Reset the basic settings 0 Switched off.* 1 Switched on.

*Basic setting

Selecting the options menu

The cooktop must be switched off.

- 1 Switch on the cooktop.
- 2 Within the next 10 seconds, touch the ⌚ symbol for 4 seconds.

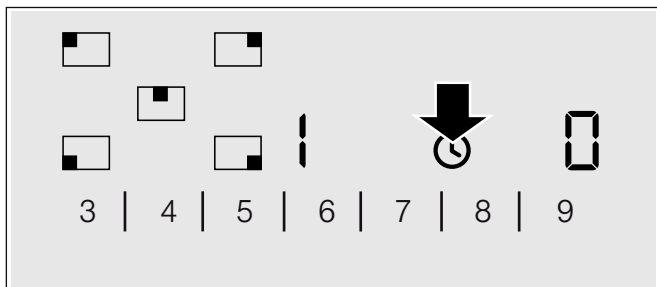

□ and ! flash alternately in the left-hand display; ⌚ lights up in the right-hand display.

- 3 Touch the ⌚ symbol repeatedly until the required indicator appears in the left-hand display.
- 4 Set the required value in the settings range.

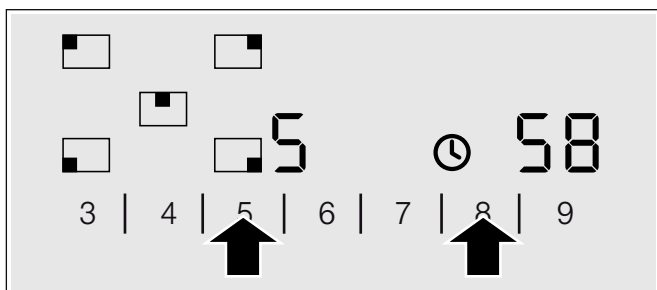

- 5 Touch the ⌚ symbol for 4 seconds.

The setting is activated.

Switching off

To exit the basic setting, switch off the hob with the main switch and make new settings.

Cleaning and care

The information in this section provides help on how best to care for your hob.

Suitable maintenance and cleaning products can be purchased from the after-sales service or in our e-Shop.

Ceramic

Clean the hob after each use. This will prevent spills from burning onto the ceramic.

Only clean the hob when it has cooled down sufficiently.

Use only cleaning agents which are suitable for ceramic. Follow the cleaning instructions on the packaging.

Never use:

- Undiluted washing-up liquid
- Detergent intended for dishwashers
- Scouring agents
- Harsh cleaning agents such as oven spray or stain remover
- Abrasive sponges
- High-pressure cleaners or steam jet cleaners

Ground-in dirt can be best removed with a glass scraper, available from retailers. Please note the manufacturer's instructions.

You can also obtain a suitable glass scraper from our after-sales service or from the e-Shop.

Hob surround

To prevent damage to the hob surround, observe the following instructions:

- Use only hot soapy water.
- Wash new sponge cloths thoroughly before use.
- Do not use any sharp or abrasive agents.
- Do not use the glass scraper.

Rectifying faults

Faults often have simple explanations. Please read the notes in the table before calling the after-sales service.

The electronics of your hob are underneath the control panel. For various reasons, the temperature in this area may rise sharply.

In order that the electronics do not overheat, the hotplates are switched off as and when necessary. The *F2*, *F4*, or *F5* display appears alternately with the *H* or *h* residual heat indicator.

Display	Fault	Measure
Blank	There is no power supply.	Check the household fuse for the appliance. Check whether there is a power cut by trying other electronic appliances.
All displays flash	The touch controls are wet or an object is resting on them.	Dry the controls or remove the object.
<i>F2</i>	Several hotplates have been used over a prolonged period at high power settings. To protect the electronics, the hotplate has been switched off.	Wait a while. Touch any touch control. When <i>F2</i> goes out, the electronics have cooled down sufficiently. You can continue cooking.
<i>F4</i>	Despite the switch-off by <i>F2</i> , the electronics have become hot again. All hotplates have therefore been switched off.	Wait a while. Touch any touch control. When <i>F4</i> goes out, you can continue cooking.
<i>F5</i> and the heat setting flash alternately. An audible signal can be heard	Warning: There is a hot pan in the area of the control panel. There is a risk that the electronics will overheat.	Remove the pan. The fault display goes out shortly afterwards. You can continue cooking.
<i>F5</i> and audible signal	There is a hot pan in the area of the control panel. To protect the electronics, the hotplate has been switched off.	Remove the pan. Wait a while. Touch any touch control. When <i>F5</i> goes out, you can continue cooking.
<i>F7</i>	Frying sensor faulty.	Acknowledge the fault message by touching a touch control. You can cook without the sensor frying system. Call the after-sales service.
<i>F8</i>	The hotplate was in operation for too long and has switched itself off.	You can switch the hotplate back on again immediately.

After-sales service

Our after-sales service is there for you if your appliance should need to be repaired. We are committed to find the best solution also in order to avoid an unnecessary call-out.

E number and FD number:

Please quote the E number (product number) and the FD number (production number) of your appliance when contacting the after-sales service. The rating plate bearing these numbers can be found on the appliance certificate.

Please note that a visit from an after-sales service engineer is not free of charge, even during the warranty period.

Please find the contact data of all countries in the enclosed customer service list.

To book an engineer visit and product advice

GB	0344 892 8988 Calls charged at local or mobile rate.
IE	01450 2655 0.03 € per minute at peak. Off peak 0.0088 € per minute.
AU	1300 368 339
NZ	09 477 0492

Trust the expertise of the manufacturer, and rest assured that the repair will be carried out by trained service technicians using original spare parts for your domestic appliance.

Gaggenau Hausgeräte GmbH
Carl-Wery-Straße 34
81739 München
GERMANY
www.gaggenau.com

GAGGENAU



9001159456 en (960628)