

VG231320HK

Gas wok (HK Town Gas)

煤氣炒鍋 (香港煤氣)

Attention! According to the Gas Safety Ordinance of Hong Kong, any gas installation works including installation of appliances and connection tubing, must be undertaken by registered gas installers who are registered for that appropriate classes and be employed by registered gas contractor.

Use approved gas tubing bearing EMSD approval marking (example: 機電工程署批准 EMSD APPROVAL GTXXXX) for connection to appliances or other appropriate methods accepted by EMSD.

注意！根據香港氣體安全條例，任何氣體裝置工程，包括爐具和接駁喉管的安裝，必須由註冊氣體裝置技工執行，而該技工已於相關的氣體工程類別註冊和受聘於註冊氣體工程承辦商。

使用認可印有機電工程署批准標記（例如：機電工程署批准 EMSD APPROVAL GTXXXX）的氣體接駁喉管連接爐具，或使用機電工程署接納的其他恰當方法。

Table of contents

Additional information on products, accessories, replacement parts and services can be found at www.gaggenau.com and in the online shop www.gaggenau.com/zz/store

This instruction manual has been translated into Chinese. If there is any inconsistency or ambiguity between the English version and the Chinese version, the English version shall prevail.

Intended use	3
Important safety information	4-5
Causes of damage	6
Environmental protection	6
Saving energy	6
Environmentally-friendly disposal	6
Familiarising yourself with your appliance	7-8
Gas wok	7
Visual signals of the luminous disc	7
Special accessories	7
Individual parts of the wok burner	8
Operating the appliance	8
Switching on	9
Thermoelectric flame monitoring	9
Switching off	9
Residual heat indicator	9
Table of settings and tips	10
Tips for cooking and roasting	10
Tips for using a wok	10
Information and tips regarding cookware	11
Suitable cooking vessels	11
Precautions for use	11
Cleaning and maintenance	12
Cleaning the appliance	12
Burnt-on dirt	12
Burner discolouration	12
Trouble shooting	13
After-sales service	14
E number and FD number	14

Intended use

Read these instructions carefully. Only then will you be able to operate your appliance safely and correctly. Retain the instruction manual and installation instructions for future use of for subsequent owners.

This appliance is only intended to be fully fitted in a kitchen. Observe the special installation instructions.

This appliance must be installed according to the installation instructions included.

Check the appliance for damage after unpacking it. Do not connect the appliance if it has been damaged in transport.

Attention! According to the Gas Safety Ordinance of Hong Kong, any gas installation works including installation of appliances and connection tubing, must be undertaken by registered gas installers who are registered for that appropriate classes and be employed by registered gas contractor. Use approved gas tubing bearing EMSD approval marking (example: 機電工程署批准EMSD APPROVAL GTXXXX) for connection to appliances or other appropriate methods accepted by EMSD.

Only allow a registered gas installer to connect the appliance. Damage caused by incorrect connection is not covered under warranty.

This appliance is intended for domestic use and the household environment only. This appliance must only be used to prepare food and drinks and must never be used as a heater. Do not leave the appliance unattended during operation. Only use the appliance indoors.

Do not install this appliance on boats or in vehicles.

This appliance is intended for use up to a maximum height of 4000 metres above sea level.

This appliance is not intended for operation with an external clock timer or a remote control.

Do not use inappropriate child safety shields or hob guards. These can cause accidents.

This appliance may be used by children and by persons with reduced physical, sensory or mental capabilities or by persons with a lack of experience or knowledge if they are supervised or are instructed by a person responsible for their safety how to use the appliances safely and have understood the associated hazards.

General maintenance works of the appliance must be undertaken by our trained registered gas installers.

Keep children at a safe distance from the appliances and power cable.

Close the safety valve on the gas supply line if the appliances will not be used for a prolonged period.

Important safety information

Warning - WHAT TO DO IF YOU SMELL GAS!

Escaping gas may cause an explosion.

If you smell gas or notice any faults in the gas installation:

- Immediately shut off the gas supply.
- Immediately extinguish all naked flames and cigarettes.
- Do not turn on or turn off any light or appliance switches and do not pull any plugs out of sockets. Do not use any telephones or mobile phones within the building.
- Open windows and ventilate the room.
- Call the after-sales service or the gas supplier.

Warning - Risk of asphyxiation!

The use of appliance leads to a build-up of heat, moisture and products of combustion in the room where the appliance is installed. Ensure that the installation room is well ventilated. The natural ventilation openings must be kept open or a mechanical ventilation device must be provided (e.g. an extractor hood). Intensive and persistent use of the appliance may mean that it is necessary to have additional ventilation (e.g. opening a window), or more effective ventilation (e.g. operating the existing mechanical ventilation device at a higher setting).

Warning - Risk of fire!

- Hot oil and fat can ignite very quickly. Never leave hot fat or oil unattended. Never use water to put out burning oil or fat. Switch off the appliance. Extinguish flames carefully using a lid, fire blanket or something similar.
- The appliance become very hot. Never place combustible items on the appliance.
- The appliance becomes very hot and flammable materials could catch fire. Never store or use flammable objects (e.g. spray cans, cleaning agents) under the appliance or in its immediate vicinity. Never place flammable items on or in the appliance.
- When appliance is in operation without any cookware placed on them, it can build up a lot of heat. The appliance and the extractor hood

above it may become damaged or be set on fire. Grease residue in the filter of the extractor hood may ignite. Only operate the appliance with cookware on them.

- If the burner does not ignite after 15 seconds, switch off the control knob and open the door or window in the room. Wait at least 1 minute before igniting the burner again.

Warning - Risk of burns!

- The appliance becomes hot during operation. Allow the appliance to cool down before cleaning.
- The appliance and surrounding area (particularly the burner surround, if fitted) become very hot. Never touch the hot surfaces. Keep children at a safe distance.
- The accessible parts become very hot when in operation. Never touch hot parts. Keep children at a safe distance.
- When the appliance cover is closed, heat will accumulate. Only close the appliance cover when the appliance has cooled down. Never switch the appliance on with the appliance cover closed. Do not rest food on the appliance cover or use it to keep food warm.
- Empty cookware becomes extremely hot when set on an appliance that is in operation. Never heat up empty cookware.

⚠ Warning - Risk of injury!

- Incorrect repairs are dangerous. Repairs may only be carried out, and damaged power and gas lines replaced, by a registered gas installer trained by us. If the appliance is faulty, unplug the mains plug or switch off the circuit breaker in the fuse box. Shut off the gas supply. Contact the after-sales service.
- Faults or damage to the appliance are dangerous. Never switch on a faulty appliance. Unplug the appliance from the mains or switch off the circuit breaker in the fuse box. Shut off the gas supply. Contact the after-sales service.
- Unsuitable pan sizes, damaged or incorrectly positioned pans can cause serious injury. Observe the instructions which accompany the cookware.

⚠ Warning - Risk of electric shock and serious injury!

- The cable insulation on electrical appliances may melt when touching hot parts of the appliance. Never bring electrical appliance cables into contact with hot parts of the appliance.
- Do not use any high-pressure cleaners or steam cleaners, which can result in an electric shock.
- A defective appliance may cause electric shock. Never switch on a defective appliance. Unplug the appliance from the mains or switch off the circuit breaker in the fuse box. Contact the after-sales service.
- Incorrect repairs are dangerous. Repairs may only be carried out by one of our trained registered gas installers. If the appliance is faulty, unplug the mains plug or switch off the circuit breaker in the fuse box. Contact the after-sales service.

Causes of damage

Caution!

- **Risk of heat damage to adjacent appliances or kitchen units:** If the appliance is in operation for an extended period, heat and moisture will be generated. Additional ventilation is required. Open the window or switch on an extractor hood that discharges the extracted air and moisture outside the building.
- **Risk of damage to the appliance due to the build-up of heat:** Do not heat roasters, frying pans or grill stones using more than one burner at a time.
- **Malfunction:** Always turn the control knob to the "Off" position when the appliance is not being used.

Environmental protection

The sections below list a number of energy-saving tips and provide information on disposing of your appliance.

Saving energy

- Choose a burner of roughly the same size as your pan. Place the cookware in the middle.
- Use small saucepans for small quantities. Using a large saucepan with little in it consumes a lot of energy.
- Always place suitable lids on saucepans. Cooking without a lid consumes significantly more energy. Use a glass lid so that you can see into the pan without having to lift the lid.
- Cook with only a little water. This will save energy and preserve the vitamins and minerals in vegetables.
- Switch to a lower heat setting in good time. This will save energy.

Environmentally-friendly disposal

Dispose of packaging in an environmentally-friendly Manner.

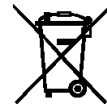

This appliance is labelled in accordance with European Directive 2012/19/EU concerning used electrical and electronic appliances (waste electrical and electronic equipment - WEEE). The guideline determines the framework for the return and recycling of used appliances as applicable throughout the EU.

Familiarising yourself with your appliance

Gas wok

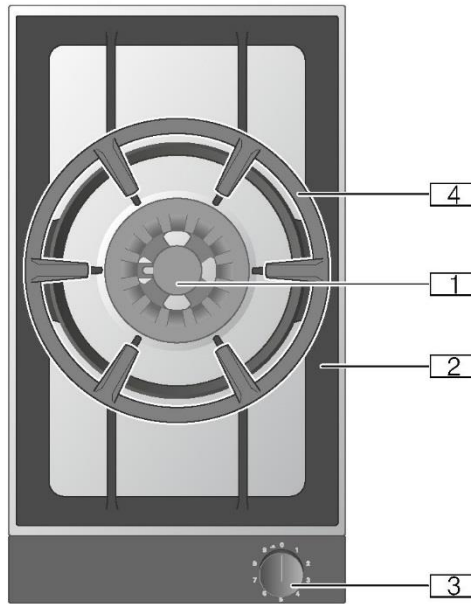

1. Wok burner 6.0 kW (HK Town Gas)
2. Pan support
3. Control knob:
 - 0 = Burner switched off
 - Power level 1 = Lowest setting
 - Power level 9 = Highest setting
 - ◀ Direction of rotation to switch on
4. Wok ring

Visual signals of the luminous disc

The control knob is encircled by an illuminated ring that indicates a number of statuses and functions.

Indicator/symbol	Meaning
○ Off	Appliance OFF
● Lit orange	Appliance ON
⚡ Slow flashing orange	Appliance OFF Residual heat indicator
⚡ Flashing orange	Appliance fault Call the after-sales service.

Special accessories

You can order the following special accessories from your specialist dealer:

WP 400 001 Wok made from multi-layer material. Features a domed bottom and handle, dia.: 36 cm, capacity: 6 litres, height: 10 cm.

Only use the accessories as specified. The manufacturer accepts no liability if these accessories are used incorrectly.

Note: If you are using the appliance cover (VD 200), once the appliance has cooled down, you must turn the wok burner pan support over before closing the appliance cover.

Individual parts of the wok burner

Ensure that the individual parts of the wok burner are fitted in the correct position and are straight; otherwise, this may result in ignition problems or problems during operation. It may cause incomplete combustion, risk of carbon monoxide poisoning and burner caps deformation due to uneven flame shape and lighting back.

Fit the burner head such that the thermocouple is positioned in the corresponding recess on the burner head. The lug on the burner ring must engage in the corresponding recess on the burner head.

Note: If the burner parts are fitted at an angle, the appliance will not work.

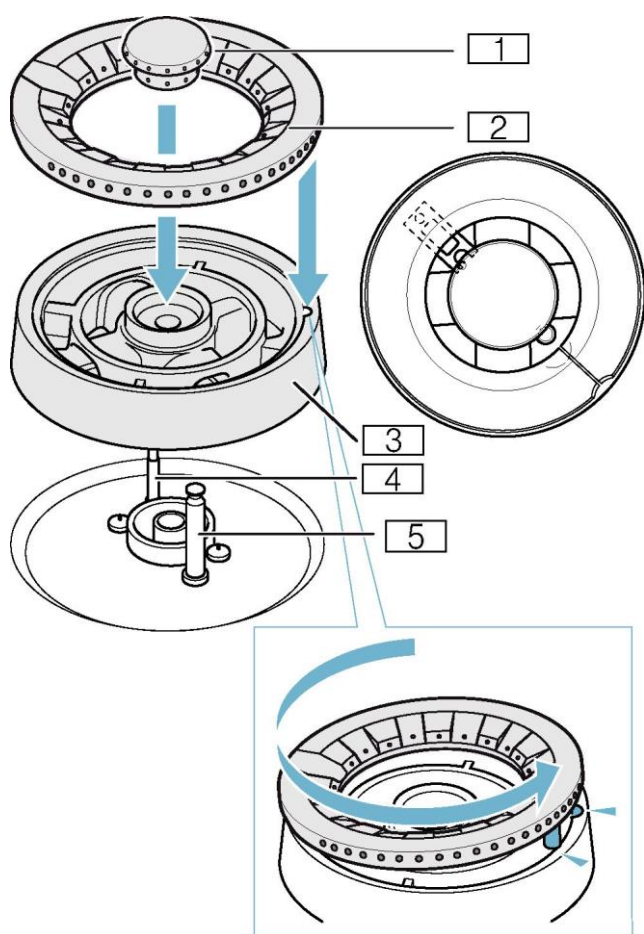

1. Burner cap
2. Burner ring
3. Burner head
4. Thermocouple
5. Ignition plug

Operating the appliance

Notes

- Only use the accessories specified. Do not line the stainless steel recess (e.g. with aluminium foil).
- Do not cover the ventilation openings on the rear of the control panel.
- The burner and ignition plug must be clean and dry.
- Only light the burner if the pan supports and all burner parts are correctly fitted.
- To ignite a burner, firmly press the control knob down as far as possible and hold it there, then turn it to the required position.
- Once ignited, press and hold the control knob for approx. 2 to 4 seconds to enable the thermocouple that opens the gas flow to heat up first.
- If the flame does not ignite within 2 to 4 seconds, turn the control knob anti-clockwise to the lowest setting and, once ignited, turn it back to the highest setting. It can often be quicker to ignite the burner in the lowest setting because different gases have different ignition characteristics.
- Do not touch the ignition plug while the appliance is being lit.
- It is important to keep the appliance clean. If the ignition plugs are dirty, this may cause ignition problems. Clean the ignition plugs regularly with a small, non-metallic brush. Take care to prevent the ignition plugs from suffering any heavy knocks.

Switching on

This appliance is equipped with a step valve. The markings on the control knob show you the output from power levels from 1 (smallest power setting) to 9 (largest power setting).

This appliance comes with ignition plugs for electrical ignition.

1. Place a suitable item of cookware on the pan support.
2. Push in the control knob for your chosen burner and turn it clockwise to the power level you require. The burner ignites automatically.

Turn the control knob to set the power level.

Caution!

Damage to the appliance

Never try to turn the control knob directly from position 0 to position 1, or from position 1 directly to position 0. Doing this will damage the step valve.

Warning – Risk of deflagration!

If the burner does not ignite after 15 seconds, switch off the control knob by turning the control knob clockwise to position 0 and open the door or window in the room. Wait at least 1 minute before igniting the burner again.

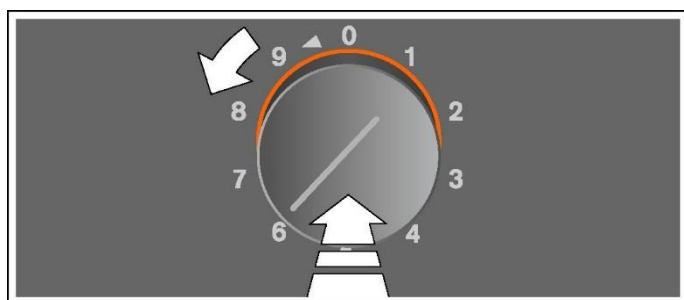

Thermoelectric flame monitoring

For your safety, the appliance is fitted with thermoelectric flame monitoring. This prevents the flow of gas if the burner accidentally goes out while it is in use (e.g. due to draughts).

If the burner accidentally goes out while it is in use, turn the control knob to the 0 position and wait at least one minute before you ignite the burner again.

Switching off

Turn the control knob clockwise to position 0.

Warning – Risk of burns!

When the appliance cover (optional accessory) is closed, heat will accumulate. Only close the appliance cover when the appliance has cooled down. Never switch the appliance on with the appliance cover closed. Do not rest food on the appliance cover or use it to keep food warm.

Residual heat indicator

The illuminated ring on the control knob will light up orange after switching off the appliance, and it will remain lit until the appliance has cooled enough for it to be safe to touch. The light will get dimmer as the appliance cools down.

Table of settings and tips

Power level	Cooking method	Examples
9	Heating	Water, clear soups
	Blanching	Vegetables
	Deep-frying	Chips, pastries
7 - 9	Searing	Meat
	Frying at high temperatures	Meat, potatoes
6 - 8	Simmering with the lid open	Liquids, dough-based foods
5 - 7	Baking	Flour-based food
	Frying at medium temperatures	Poultry, fish
4 - 5	Frying at low temperatures	Fried sausages, onions, egg dishes
	Defrosting	Frozen food
4	Poaching with the lid open	Dumplings, boiled sausages
	Warming	Vegetables, soups, stews
3 - 4	Braising	Beef olives, joints
	Stewing	Vegetables
2 - 4	Simmering with the lid on	Soups, vegetables
1	Soaking	Rice, rice pudding, cereals

Tips for cooking and roasting

The values given in the settings table must be looked upon as recommended values. The heat required depends not only on the type and condition of the food, but also the size and contents of the pot.

Due to the high performance of the appliance, fat and oil will heat up quickly. Never leave the appliance unattended, fat can ignite, food can burn.

Tips for using a wok

Note: When you cook using a wok, place the wok ring onto the pan support over the wok burner. Make sure that the wok is stable on the wok ring when you are cooking.

We recommend using woks with a domed base. You can order a high-quality wok as an optional accessory (WP 400 001).

When cooking with the wok, use only cooking oil that is suitable for heating to high temperatures, such as groundnut oil.

Cook the ingredients at a high heat, while stirring constantly. Do not cook them for too long. The vegetables should be al dente.

For stirring the food and for taking it out of the wok, it is best to use a shallow ladle with a long handle made from a heat-resistant material.

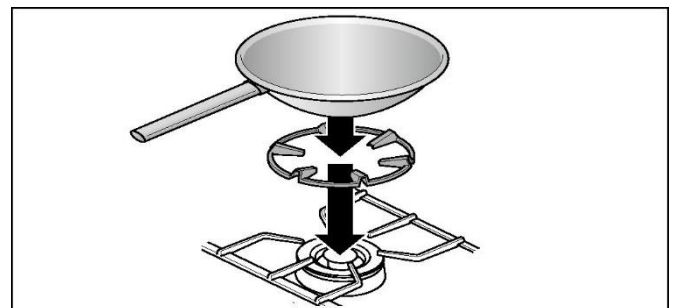

Information and tips regarding cookware

The following information and tips have been provided to help you save energy and avoid damaging your cookware.

Suitable cooking vessels

Burner	Recommended pan base diameter	Minimum pan base diameter
Wok burner	240-300 mm Use the wok only on the wok ring.	160 mm

Pans with a diameter of less than 160 mm or more than 300 mm should not be used.

Maintain a distance of at least 50 mm between the item of cookware and flammable objects. Maintain a distance of at least 50 mm between the control knob or control panel and the pot or pan. The cookware must not touch the control panel or the control knob. The cookware must not protrude over the edge of the appliance.

Maximum weight of cookware placed on the burner shall not exceed 20 kg.

Precautions for use

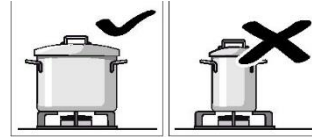

Use pots or pans which are the right size for each burner. Do not use small pots or pans on large burners. The flame should not touch the sides of the pot.

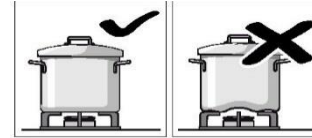

Do not use damaged pots or pans, which do not sit evenly on the appliance, they may tip over.

Only use pots or pans with a thick, flat base.

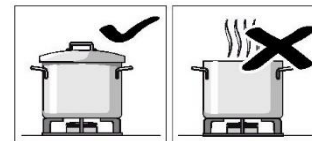

Do not cook without using a lid and make sure the lid is properly fitted. This wastes energy.

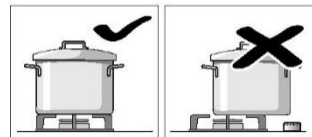

Always centre the pot or pan over the burner, otherwise it could tip over.

Do not place large pots on the burners near the control knobs. These may get damaged by the high temperatures.

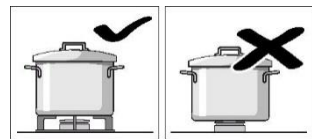

Place the pots or pans on the pan support, never directly on the burner.

Make sure that the pan supports and burner caps are correctly positioned before using the appliance.

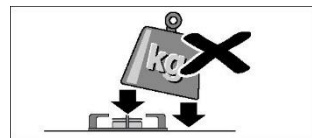

Pots or pans should be placed on the appliance carefully.

Do not strike the appliance and do not place excessive weight on it.

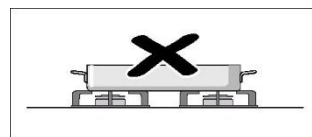

Do not heat a cooking vessel (e.g. roaster, pan, grill stone) on more than one burner at the same time. The resulting heat accumulation will damage the appliance.

Cleaning and maintenance

⚠ Warning - Risk of electric shock!

Do not use any high-pressure cleaners or steam cleaners, which can result in an electric shock.

⚠ Warning - Risk of burns!

The accessible parts become very hot when in operation. Never touch hot parts. Keep children at a safe distance.

Caution!

Risk of surface damage

Do not use these cleaners

- harsh or abrasive cleaning agents
- oven cleaners
- corrosive or aggressive cleaners, or those containing chlorine
- cleaning agents with a high alcohol content
- hard and scratchy sponges, brushes or scouring pads

If such an agent comes into contact with the appliance, wash it off immediately with water.

Thoroughly wash out new sponge cloths before using them!

Cleaning the appliance

Clean the appliance after each use once it has cooled down. Remove spilt liquids immediately and do not allow any food remains to burn on.

Dry the burners thoroughly after cleaning. Only operate the appliance when the burners are dry. Damp burners can cause ignition problems and/or an unstable flame.

During assembly, make sure that the burner parts (catch tappets) are in the correct position. All parts must be straight. For the installation sequence, please refer to the image of "Individual parts of the wok burner" on page 8.

Appliance part/ surface	Recommended cleaning
Stainless steel surfaces	Use soapy water and dry with a soft cloth. Use a minimal amount of water when cleaning to prevent water from penetrating the appliance. Soak burnt-on remains with a small amount of soapy water; do not scour. Remove heavy soiling or yellow discolouration caused by heat using our stainless steel cleaning agent (item no. 00311499).
Pan supports, wok ring	Carefully remove for cleaning. Soak in the sink. Clean using a scrubbing brush and detergent. Clean the area around the rubber buffers carefully so that they do not become detached. Rinse with clean water and dry before placing back on the appliance. Do not clean them in the dishwasher.
Burner cap, burner ring, burner head	Take out these burner parts and use soapy water and dry with a soft cloth. Make sure that the openings are not blocked. Make sure that no small parts are lost. Do not clean them in the dishwasher.
Ignition plug	Clean the ignition plugs regularly with a small, non-metallic brush. Take care to prevent the ignition plugs from suffering any heavy knocks.
Control panel	The soapy cloth must not be too wet. Dry with a soft cloth.
Control knob	The soapy cloth must not be too wet. Dry with a soft cloth. Caution! Damage to the appliance Do not detach the control knob to clean.

Burnt-on dirt

For hard-to-remove, burnt-on dirt, you can order a cleaning gel from our online shop, from your specialist retailer or our after-sales service (item number 00311859). It is suitable for pan supports and the stainless-steel recess. If necessary, let the dirt soak overnight. Follow the instructions on the cleaning agent.

Caution!

Damage to the surface

Do not use the cleaning gel on the burner parts, the control panel or the control knobs.

Burner discolouration

After extended use, the brass burner parts take on a darker colour as a result of the oxidation process that occurs naturally. The discolouration does not affect their serviceability.

Trouble shooting

⚠ Warning - Risk of electric shock!

Incorrect repairs are dangerous. Repairs may only be carried out by one of our registered gas installer. If the appliance is faulty, unplug the mains plug or switch off the circuit breaker in the fuse box. Contact the after-sales service.

Faults often have simple explanations. Please read the following notes before calling the after-sales service.

Fault	Possible cause	Solution
Malfunction of the general electrical system.	The household fuse has tripped.	Check the fuse box if the circuit breaker has tripped.
The electric ignition does not work.	There may be food or cleaning products stuck between the ignition sparkers and the burners.	The space between the ignition sparker and the burner must be clean.
	The burner parts are wet.	Dry the burner parts carefully.
	The burner parts are not correctly positioned.	Check that the burner parts are correctly positioned. Please refer to the image of "Individual parts of the wok burner" on page 8.
The burner flame is not uniform.	The burner parts are not correctly positioned.	Check that the burner parts are correctly positioned. Please refer to the image of "Individual parts of the wok burner" on page 8.
	The recess of the burner parts are dirty.	Clean the recess of the burner parts.
The gas flow is not normal or there is no gas.	The gas supply is blocked via gas taps.	Open all gas taps.
The kitchen smells of gas.	Gas may be leaking out.	Extinguish all naked flames. Open windows and ensure the room is well ventilated. Stop the gas flow immediately by turning off the emergency control valve upstream of the gas meter (the main switch of the gas meter) if possible. Contact gas supply company and appliance supplier to check all your gas installations including gas appliances.
The burner goes off after ignition.	The control knob was not held down for long enough.	Once the burner is on, hold the control knob down a few seconds longer. Fully press control knob.
	The recess of the burner parts are dirty.	Clean the recess of the burner parts.

After-sales service

Our after-sales service is there for you if your appliance needs to be repaired. We will always find an appropriate solution, also in order to avoid after-sales personnel having to make unnecessary visits.

E number and FD number

When calling us, please quote the full product number (E no.) and the production number (FD no.) so that we can provide you with the correct advice. The rating plate that features these numbers can be found on the underside of the appliance.

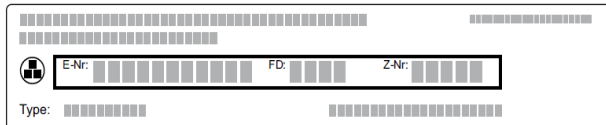

To save time, you can make a note of the numbers for your appliance and the telephone number of the after-sales service in the space below in case you need them.

E no.

FD no.

After-sales service ☎

Please note that a visit from an registered gas installer is not free of charge in the event that the appliance has been misused, even during the warranty period.

Please find the contact data of all countries in the enclosed customer service list.

To book an after-sale service and product advice

HK 2553 8353

Trust the expertise of the manufacturer, and rest assured that the repair will be carried out by registered gas installer using original spare parts for your domestic appliance.

目錄

關於產品、配件、備品與保養的其他資訊，請參閱
www.gaggenau.com 與線上商店
www.gaggenau.com/zz/store

此使用說明書為英文版本譯本，如中、英文兩個版本有任何抵觸或不相符之處，以英文版本為準。

使用前須知	17
重要安全訊息	18
損壞原因	19
環境保護	19
節省能源	19
合環保規定的廢棄物處理	19
了解您的爐具	20-21
煤氣炒鍋	20
照明裝置的視覺信號	20
特殊配件	20
炒鍋爐頭的個別組件	21
操作爐具	21
開啟	21
電子式火候監控與自動再點火	22
關閉	22
餘溫指示燈	22
設定表與提示	23
烹調與燒烤的秘訣	23
使用炒鑊的小技巧	23
於鍋具的提示與資訊	24
適用的烹調工具	24
使用時的注意事項	24
清潔與保養	25
清潔本爐具	25
燒焦的污物	25
爐頭泛黃	25
疑難排解	26
售後服務	27
產品編號及生產編號	27

使用前須知

詳細閱讀說明才可以安全並正確地使用本產品請妥善保管說明手冊及安裝說明，以便您在日後或供下一位使用者查閱。

本爐具必須完整地安裝於廚房中。請遵照特定的安裝說明。

本爐具必須根據隨附的安裝說明書進行安裝。

打開包裝後，請檢查爐具有否損壞。如爐具在運送過程中受損，請切勿安裝。

注意！根據香港氣體安全條例，任何氣體裝置工程，包括爐具和接駁喉管的安裝，必須由註冊氣體裝置技工執行，而該技工已於相關的氣體工程類別註冊和受聘於註冊氣體工程承辦商。

使用認可印有機電工程署批准標記（例如：機電工程署批准EMSD APPROVAL GTXXXX）的氣體接駁喉管連接爐具，或使用機電工程署接納的其他恰當方法。

只能由註冊氣體裝置技工接駁爐具。保養不包括因不當連接而造成的損壞。

此爐具只供家庭及家居環境中使用。本爐具僅適用於準備食物和飲品，不可當做暖爐來使用。爐具運作時，請勿離開不理。僅供室內使用。

請不要將本爐具安裝在船隻或運輸工具上。

本爐具僅適用於最高海拔4000米以下地區。

本爐具不適合與外部計時器或遙控操作搭配使用。

請勿使用不適當的兒童安全防護罩或爐頭保護器具。這些可能會導致意外事故。

兒童、身體、感官或心智能力欠佳者、或欠缺使用經驗與知識者，在使用本爐具時，須由負責其安全並明瞭相關風險之人士從旁監督或指導，以安全地使用爐具。

只可由我們受過訓練的註冊氣體裝置技工執行爐具維修工作。

兒童應與爐具和電源線保持安全的距離。

若爐具將有一段長時間不使用，請關閉煤氣供給管線上的安全閥。

重要安全訊息

警告 - 聞到煤氣味時該做的事！

煤氣洩漏可能會導致爆炸。

若聞到煤氣味或發現氣體安裝上有缺陷：

- 立刻關閉煤氣供應。
- 立刻滅掉所有暴露出的火焰與煙霧。
- 請勿開啟或關閉任何光源或爐具電源，以及將任何插頭從插座拔掉。請勿在建築物裡使用電話或手機。
- 打開窗戶並使房間內通風。
- 請聯絡售後服務中心或煤氣供應商。

警告 - 窒息風險！

使用爐具將會導致安裝有本爐具的房間內產生熱、濕氣及燃燒產物。請確保安裝本爐具的房間內有足夠的通風。請務必將通風口打開或使用機械式抽風機（例如抽油煙機）。若密集地或持續地使用本爐具，需有額外的通風（例如打開窗戶）或更有效的通風（例如將既有的機械式抽風機開大一點）。

警告 - 火災風險！

- 熱油和脂肪會快速燃燒。務必注意熱脂肪或油的使用。切勿使用水澆熄正在燃燒的油或脂肪。關閉發熱的爐具。小心使用蓋子、滅火毯或類似的物品來滅火。
- 發熱的爐具變得非常熱。切勿將易燃物品放置於爐具上。
- 爐具過熱的話，可能會使易燃物著火。請勿在本爐具的下方或鄰近處放置或使用易燃物品（例如噴罐、清潔劑）。請勿在本爐具的上方或內部放置易燃物品。
- 如果爐具在運作中沒有放置任何廚具，爐具會產生高溫。本爐具與其上方的抽油煙機可能會損壞或起火。抽油煙機的濾網上所殘留的油脂可能會引起點火。因此，必須在放上廚具後才操作爐具。
- 假如爐頭在15秒後，還是沒有燃點，關閉控制旋鈕，並開啟房間內的窗或門。再次燃點爐頭前，需等待至少1分鐘。

警告 - 灼傷風險！

- 爐具在運作時會變得很熱。清潔前，請務必等待爐具完全冷卻。
- 發熱的爐具及周圍區域（特別是爐頭附近區域）會變得非常熱。請勿觸碰高溫表面。請勿讓兒童走近此爐具。
- 運作時可接觸部分會變得非常灼熱。請勿碰觸。請勿讓兒童走近此爐具。
- 當爐具的蓋子（自選配件）關閉時，熱能會累積。請在本爐具完全冷卻後再關閉爐具的蓋子。請勿在爐具蓋子蓋上的狀態下開啟本爐具的電源。請勿將食物放在爐具蓋子上或使用蓋子來保溫食物。
- 空鍋具放在運作中的爐具上會變得非常燙。請勿

加熱空的鍋具。

警告 - 受傷風險！

- 不當維修會造成危險。請由受過本公司訓練的註冊氣體裝置技工進行維修或更換損壞的電線、煤氣管線。爐具如有故障，請拔掉爐具插頭或關閉保險絲盒內的斷路器。關閉煤氣供給。請聯絡售後服務中心。
- 有缺陷或損傷的爐具非常危險。爐具若有缺陷請勿開啟其電源。請拔掉爐具插頭或關閉保險絲盒內的斷路器。關閉煤氣供給。請聯絡售後服務中心。
- 尺寸不合適的平底鍋、已受損或沒放置好的平底鍋將導致受傷。請遵照鍋具隨附的指示。

警告 - 觸電與重傷風險！

- 爐具的電線絕緣部分會因接觸爐具高溫部分而溶化。切勿讓電線接觸爐具高溫的部分。
- 請勿使用任何高壓清潔器或蒸氣清洗機，以免觸電。
- 損壞的爐具可能導致觸電。請勿開動損壞的爐具。請拔掉爐具插頭或關閉保險絲盒內的斷路器。請聯絡售後服務中心。請聯絡售後服務中心。
- 不當維修會造成危險。爐具只可由我們受過訓練的註冊氣體裝置技工維修。爐具如有故障，請拔掉主電源插頭或關閉保險絲盒內的斷路器。請聯絡售後服務中心。

注意！

- **對鄰近爐具或廚房用具造成熱損壞：**當爐具運作了一段時間後會產生熱與濕氣。需要有額外的通風。打開窗戶或啟動抽油煙機將抽出的空氣及濕氣排放到建築物外面。
- **因熱能累積會導致爐具損壞：**請勿一次使用一個以上的爐頭來加熱烤盤、平底鍋或燒烤石。
- **故障：**當爐具沒有使用時，請總是將控制旋鈕轉至「關閉」位置。

下一個章節裡，我們明列了節能秘訣與爐具廢棄處理相關資訊。

節省能源

- 選擇和您的平底鍋大小差不多的爐頭。將鍋具置於中央。
- 少量烹調時請使用小型平底深鍋。少量烹調時使用大型平底深鍋會消耗過多的能源。
- 使用適合平底深鍋的蓋子。不加蓋烹調將會消耗較多的能量。使用玻璃蓋可讓你不用打開蓋子便能看到鍋中的情況。
- 使用少量的水烹調。這可以節省能源並保留蔬菜中所有的維生素和礦物質。
- 適時切換至較低的加熱設定。如此可以節省能源。

合環保規定的廢棄物處理

以環保方式處理包裝。



此爐具根據歐盟關於使用過的電器及電子產品的指令2012/19/EU（棄置的電器及電子產品-WEEE）貼有相關標籤。該指引訂明了在歐盟範圍內舊爐具退還及回收的方法。

煤氣炒鍋

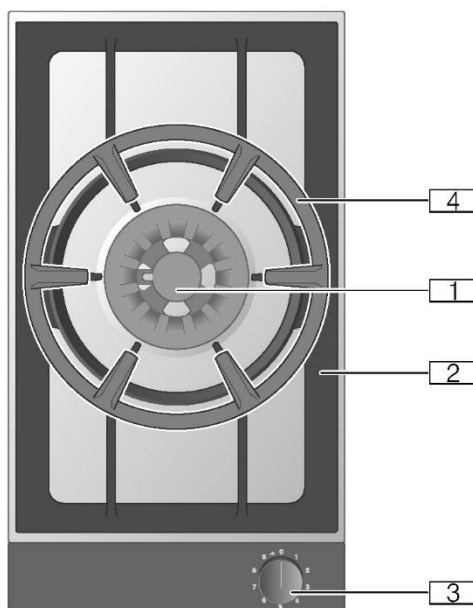

1. 炒鍋爐頭 6.0kW (香港煤氣)
2. 爐架
3. 控制旋鈕:
 - 0 = 關閉爐頭
 - 火力 1 = 最低火力設定
 - 火力 9 = 最高火力設定
 - ◀ 開啟的旋轉方向
4. 炒鍋架

照明裝置的視覺信號

環繞控制旋鈕周圍的發光圓環代表各種狀態和功能。

指示燈 / 符號	說明
○ 關閉	爐具關閉
● 亮橙燈	爐具開啟
● 緩慢閃爍橙燈	爐具關閉 餘溫指示燈
☀ 橙燈閃爍	爐具故障 請致電售後服務中心。

特殊配件

可向專業零售商購買以下的特殊配件。

WP 400 001 使用多層材料製成的炒鑊。外觀為圓底和把手，直徑36厘米、容量6公升、高度10厘米。

請勿使用指定配件以外的物品。若這些配件使用不正確，製造商將不對此負起任何責任。

提示：若您使用爐蓋 (VD 200)，當爐具冷卻後需關上爐蓋時，您必須將炒鍋爐頭的爐架翻轉。

炒鍋爐頭的個別組件

請確保炒鍋爐頭的個別組件皆安裝於正確位置，且平直無彎曲，否則可能出現點火或操作問題，當火焰不均和回火會導致不完全燃燒、一氧化碳中毒或爐頭蓋變形。安裝燃燒爐頭前端使熱電偶位於燃燒爐頭前端上相應的凹槽中。爐環上的耳狀凹槽必須接合在爐頭前端上的相應凹槽中。

提示：如果爐頭組件是依某種角度裝入，爐具將無法使用。

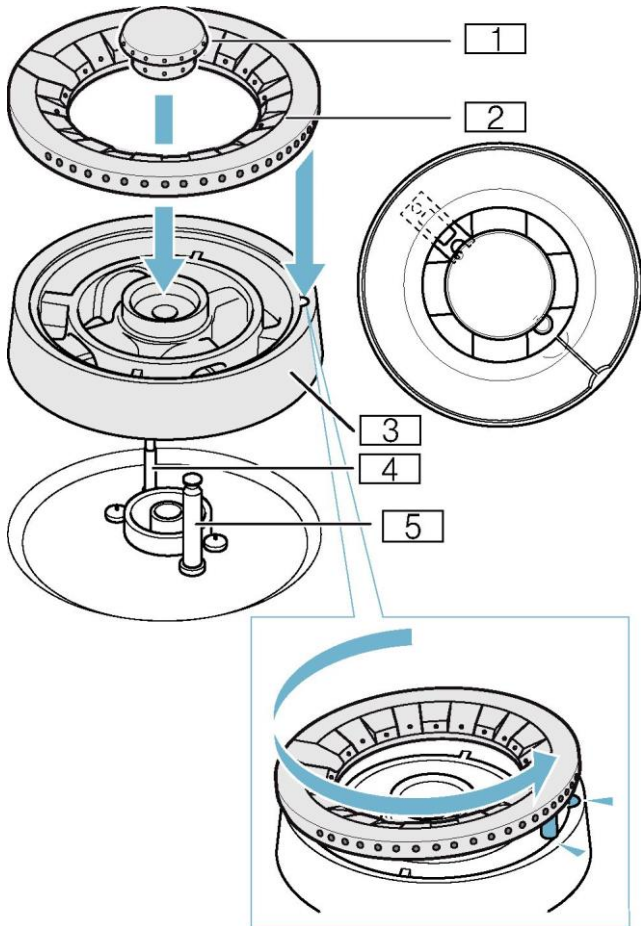

1 | 爐蓋

2 | 爐環

3 | 燃燒爐頭

4 | 熱電偶

5 | 點火器

操作爐具

提示

- 僅使用指定配件。請勿蓋住不銹鋼凹槽（例如用鋁箔蓋住）。
- 請勿遮蓋控制面板後方的通風口。
- 爐頭和點火器必須保持清潔乾燥。
- 請先確認爐架和所有爐頭組件都已正確安裝，再燃點爐頭。
- 若要燃點爐頭，請將控制旋鈕整個按下後轉至所需的位置。
- 點火後，按住控制旋鈕約2至4秒來啟動熱電偶，讓它打開煤氣流優先加熱。
- 若在2至4秒內未燃點，請將控制旋鈕逆時針轉至最低火力設定，一旦燃點後，請轉到最高火力設定。因不同的氣種有不同的燃點特性，在最低火力設定時通常可以較快燃點爐頭。
- 當爐具正在燃點時，請勿觸碰點火器。
- 保持爐具的清潔非常重要。若點火器骯髒，點火時可能會出現問題。定期使用小型非金屬刷子清潔點火器。請小心避免點火器受到嚴重撞擊。

開啟

本爐具配備有層式閥。控制旋鈕上的標記表示輸出火力 1 (最小火力設定) 至 9 (最大火力設定)。

本爐具配備有點火器進行電力點火。

1. 請在爐架上放置適當的鍋具。
2. 按壓所選爐頭的控制旋鈕，並順時鐘轉動到您需要的火力。爐頭會自動燃點。

轉動控制旋鈕以設定火力。

注意！

損壞爐具

請不要將旋鈕從位置 0 直接轉到位置 1，反之亦然，這樣會令層式閥受損。

⚠ 警告 - 爆燃風險！

假如在 15 秒後，爐頭還是沒有燃點，將控制旋鈕順時鐘轉至 0 的位置，關閉旋鈕，並開啟房間內的窗或門。再次開啟爐頭前，需等待至少 1 分鐘。

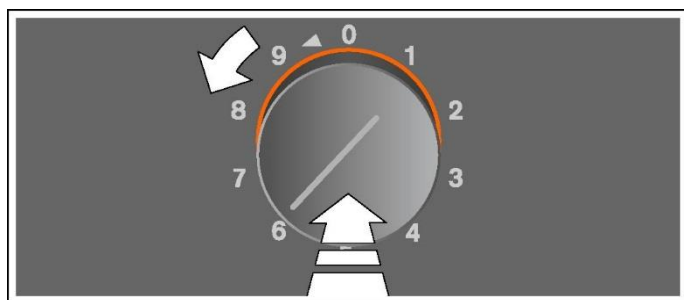

電熱式火候監控

爐具上附有電熱式火候監控以保護您的安全。如此得以防止爐頭使用時不小心熄滅而導致煤氣外洩（例如有風吹來）。

若爐頭使用時不小心熄滅，請將控制旋鈕轉至 0 的位置，並稍待一分鐘後再度將爐頭點火。

關閉

將控制旋鈕順時鐘轉至 0 的位置。

⚠ 警告 - 燙傷風險！

當爐具的蓋子（自選配件）關閉時，熱能會累積。請在本爐具完全冷卻後再關閉爐具的蓋子。請勿在爐具蓋子蓋上的狀態下開啟本爐具的電源。請勿將食物放在爐具蓋子上或使用蓋子來保溫食物。

餘溫指示燈

關閉爐具後，控制旋鈕上的發光圓環會緩緩閃爍橙燈，直到爐具完全冷卻可以觸摸後才會停止。餘溫指示燈仍在閃爍時切勿觸碰爐具。

設定表與提示

加熱設定	烹調方法	例如
9	加熱	水、清湯
	盪煮	蔬菜
	油炸	薯條、酥皮點心
7 - 9	燒炙	肉類
	高溫油炸	肉、馬鈴薯
6 - 8	打開鍋蓋煨燉	汁液、麵糰類食物
5 - 7	烘焙	麵粉類製品
	以中溫煎	家禽、魚類
4 - 5	以低溫煎	煎香腸、洋蔥、蛋類 菜式
	解凍	急凍食品
4	打開鍋蓋水煮	餃子、水煮過的香腸
	加熱	蔬菜、湯、燉菜
3 - 4	以文火燉煮	橄攪牛肉卷、西冷肉
	燉	蔬菜
2 - 4	加蓋煨燉	湯、蔬菜
1	浸泡	米、米飯布甸、穀類

烹調與燒烤的秘訣

設定列表裡的數值僅能當做參考數值。所須的加熱不僅依照食物的類型與狀態有所不同，也受到鍋子的尺寸與內裝物的影響。

由於本產品為高效能爐具，因此可快速加熱油脂和油。請千萬不可閒置爐具，油脂可能會引發點火，食物可能會燒起來。

使用炒鑊的小技巧

提示：當使用炒鑊烹煮時，將炒鍋架放在炒鍋爐頭的爐架上。烹飪時確保炒鑊可穩定放在炒鍋架上。

建議您使用半球型底座的炒鑊。您可購買高品質炒鑊當做選購配件（WP 400 001）。

當使用炒鑊烹調時，僅使用適合高溫加熱的食用油，例如花生油。

在高溫下烹調食材，並同時不斷攪拌。請勿烹調過長的時間。烹調的蔬菜應有嚼勁。

為了攪拌食物並將其從炒鑊中取出，最好使用耐熱材質製成的長手柄淺杓。

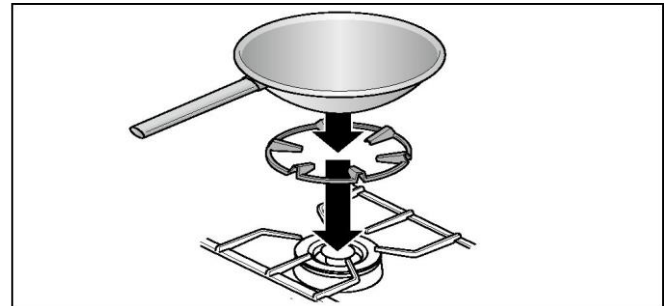

關於鍋具的提示與資訊

以下提供您節能並防止鍋具損壞的資訊和秘訣。

適用的烹調工具

爐頭	建議平底鍋底部直徑	最小平底鍋底部直徑
炒鍋爐頭	240-300 mm 僅可在炒鍋架上使用炒鑊。	160 mm

不應使用直徑少於160 mm或是大於300 mm的平底鍋。

廚具和可燃物體之間必須保持至少50毫米的距離。控制旋鈕或控制面板和鍋子或平底鍋之間必須保持至少50毫米的距離。廚具不可碰觸控制面板或控制旋鈕。廚具不可突出爐具邊緣。

放在爐頭上的鍋具最大重量不得超過20公斤。

使用時的注意事項

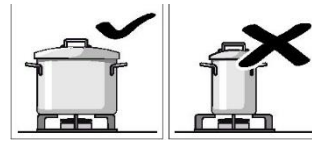

請使用適合各爐頭尺寸的鍋子或平底鍋。請勿在大的爐頭上使用過小的鍋子或平底鍋。火焰不可碰觸到鍋子的邊緣。

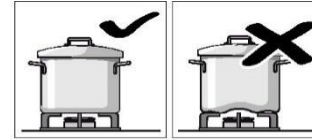

請勿使用已損壞的鍋子或平底鍋，這樣的器具無法在爐具上平均放置而可能導致傾斜外漏。請務必使用帶有厚平底的鍋子或平底鍋。

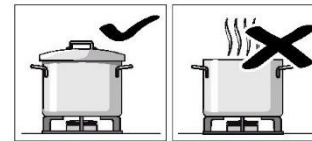

請勿在沒有使用蓋子的狀態下烹調並確保蓋子的尺寸合適。如此會造成能源浪費。

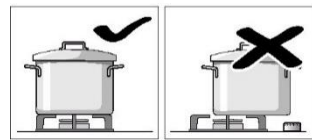

請務必將鍋子或平底鍋擺放在爐頭的中間，否則會傾斜外漏。請勿在靠近控制旋鈕的爐頭上放置過大的鍋子。這些部分可能會因為高溫而損壞。

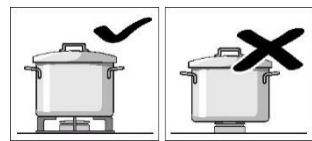

將鍋子或平底鍋放置於爐架上，務必不要直接放在爐頭上。使用本爐具前請確認爐架與爐蓋的位置有擺放正確。

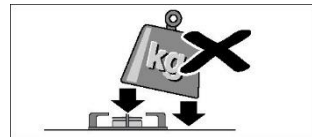

鍋子或平底鍋必須小心地放置在爐具上。請勿敲打本爐具以及於上方放置過重的物品。

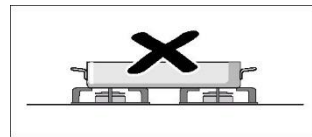

請勿同時使用一個以上的爐頭來加熱烹調器具(例如烘烤器、平底鍋、燒烤石)。所有加熱的累積能量將導致爐具損壞。

清潔與保養

△ 警告 - 觸電風險！

請勿使用任何高壓清潔器或蒸氣清洗機，以免觸電。

△ 警告 - 燙傷風險！

運作時可接觸部分會變得非常灼熱。請勿碰觸。請勿讓兒童走近此設備。

注意！

小心損害表面

請勿使用以下的清潔用品

- 強效或腐蝕性的清潔劑
- 爐用清潔劑
- 腐蝕性、強效或含氯的清潔劑
- 含高酒精成份的清潔劑
- 硬質與易刮傷的海綿、刷子或百潔布

若爐具不慎接觸到此類清潔劑，請立即用清水洗淨。新的海綿布在使用前應先徹底清潔！

清潔本爐具

每次使用完請在爐具冷卻後清潔。請立即清除溢出或濺出的液體，不要讓任何食物殘渣焦掉。

清潔完成後，徹底抹乾爐頭。務必在爐頭乾燥的狀態下操作本爐具。潮濕的爐頭將導致點火問題和/或火候不穩定。

安裝時請確保爐頭組件（固定挺桿）在正確的位置，所有組件必須是平直無彎曲的。安裝次序請參照第21頁中「炒鍋爐頭的個別組件」圖示。

爐具組件/表面	推薦的清潔方式
不銹鋼表面	請使用肥皂水清潔並以軟布擦乾。請確保清潔時使用最少量的水以避免水滲入爐具內。請將燒焦的殘渣浸泡在少量的肥皂水裡，並請不要刷洗。請使用本公司的不銹鋼清潔劑（項目編號00311499）來去除頑強污垢或因熱所導致的泛黃。
爐架、炒鍋架	清潔時，可小心地取下爐架。浸泡在水槽中。請用刷子與清潔劑清洗。請小心清潔橡膠緩衝條的四周以避免其脫落。放置爐具前請先用清水沖洗乾淨然後風乾。 請勿放入洗碗機內清洗。
爐蓋、爐環、燃燒爐頭	取出爐頭組件並請使用肥皂水清潔並以軟布擦乾。請確保開口處沒有阻塞。確定沒有遺失任何小組件。請勿放入洗碗機內清洗。
點火器	定期使用小型非金屬刷子清潔點火器。請小心避免點火器受到嚴重撞擊。
控制面板	沾有肥皂水的布不可太濕。用軟布擦乾。
控制旋鈕	沾有肥皂水的布不可太濕。用軟布擦乾。 注意！ 損壞電器 清潔時請勿拆下控制旋鈕。

燒焦的污物

針對難以清除的燒焦污物，可向網上商店、專業零售商或售後服務中心購買清潔凝膠（品項編號00311859）。本清潔凝膠適用於爐架與不銹鋼凹槽。若有需要可將污物浸泡過夜。請遵循清潔劑上的指示。

注意！

表面損壞

請勿在爐架組件、控制面板或控制旋鈕上使用清潔凝膠。

爐頭泛黃

長期使用後，黃銅製的爐頭組件會因為自然發生的氧化作用而呈現較暗的顏色。此泛黃現象並不會影響其功能。

疑難排解

△ 警告 - 觸電風險！

不當維修會造成危險。爐具只可由我們受過訓練的註冊氣體裝置技工維修。爐具如有故障，請拔掉主電源插頭或關閉保險絲盒內的斷路器。請聯絡售後服務中心。

故障的原因通常很簡單。在聯絡客戶服務前，請先閱讀下列說明。

損毀	可能原因	解決方法
一般電源系統的故障。	家裡的保險絲跳掉了。	請確認保險絲盒裡的斷路器是否已跳掉。
電點火無法正常運作。	可能有食物或清潔劑卡在點火器和爐頭之間。	請務必將點火器和爐頭之間的空間打掃乾淨。
	爐頭組件潮濕。	仔細擦乾爐頭組件。
	爐頭組件位置沒有放置正確。	請確認爐頭組件位置放置正確。請參照第 21 頁中「炒鍋爐頭的個別組件」圖示。
爐頭的火不均勻。	爐頭組件位置沒有放置正確。	請確認爐頭組件位置放置正確。請參照第 21 頁中「炒鍋爐頭的個別組件」圖示。
	爐頭組件凹槽是骯髒。	清潔爐頭組件凹槽。
煤氣流動不暢順或沒有氣。	煤氣龍頭的供給阻塞。	打開所有的煤氣龍頭。
廚房裡有煤氣味。	煤氣可能有外漏。	弄熄所有明火。 打開窗戶，並確保房間內有足夠的通風。 如情況許可，應立即關閉供氣管道於氣體錶上游的緊急控制閥（氣體錶總掣），以截斷氣體供應。 致電氣體供應公司及爐具供應商檢查所有室內氣體裝置包括氣體爐具。
爐頭點火後又熄滅。	扳下控制旋鈕的時間不夠久。	爐頭開啟後，將控制旋鈕按下數秒之久。按下整個控制旋鈕。
	爐頭組件凹槽是骯髒。	清潔爐頭組件凹槽。

售後服務

若爐具需要維修，請聯絡我們的售後服務中心。我們一定會找出適合的解決方案，同時避免售後服務人員不必要的上門服務。

產品編號及生產編號

與我們聯絡時，請提供完整的產品編號（E no.）和生產編號（FD no.），以便服務人員提供正確的建議。您可在爐具底部找到附有這些數字的銘牌。

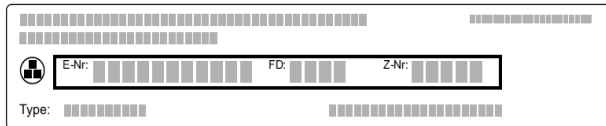

您也可以在下方空位中記下爐具編號和售後服務中心的電話號碼，省卻尋找時間。

E no.

FD no.

After-sales service ☎

請注意，即使在保固期內，若因誤用本爐具而使註冊氣體裝置技工到府服務，則仍需收費。

您可以在隨附的清單中，找到各國售後服務中心的聯絡資料。

預約售後服務並提供產品建議

HK 2553 8353

請相信製造商的專業，放心將家居爐具的維修工作交由受過訓練的註冊氣體裝置技工處理，並使用原廠組件。

BSH Hausgeräte GmbH
Carl-Wery-Straße 34
81739 München, GERMANY
www.gaggenau.com

GAGGENAU



9001396174 en, zh-hk (031224)