

2

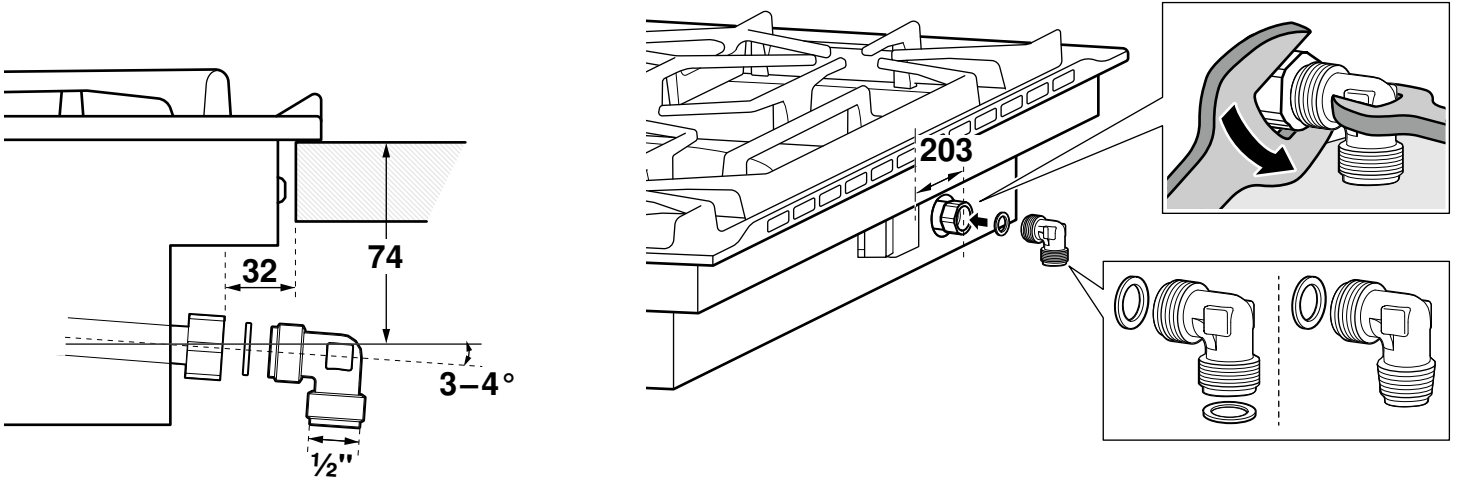

3

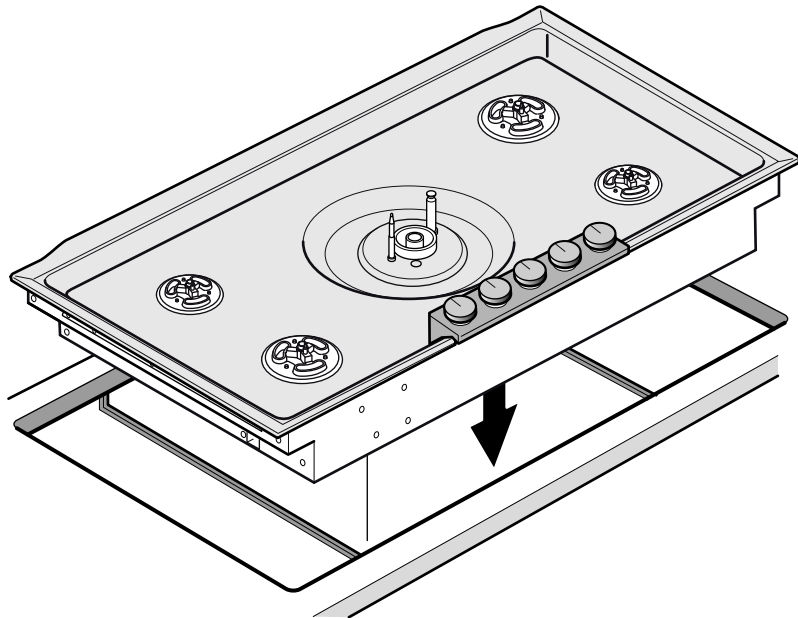

4

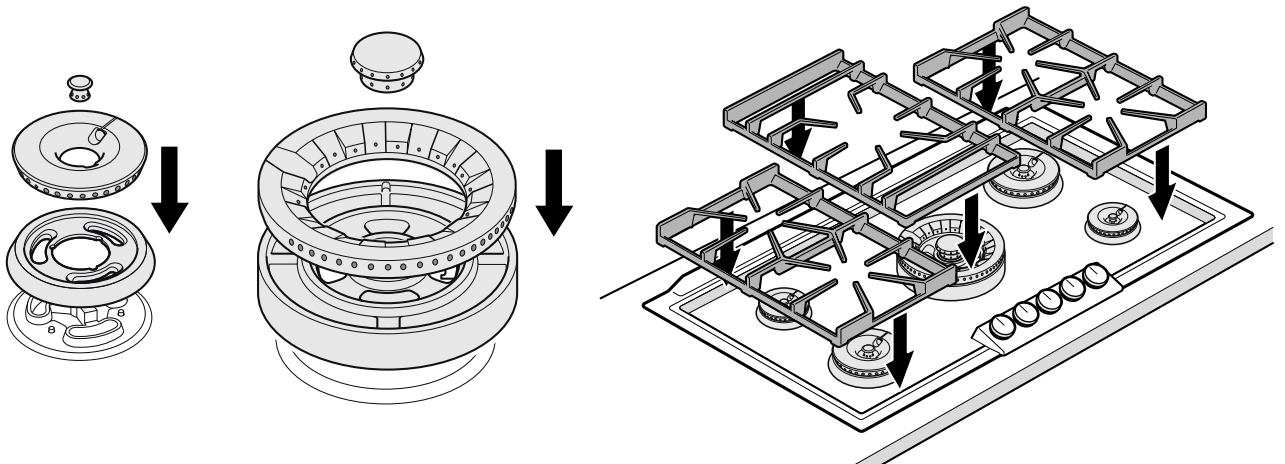

5

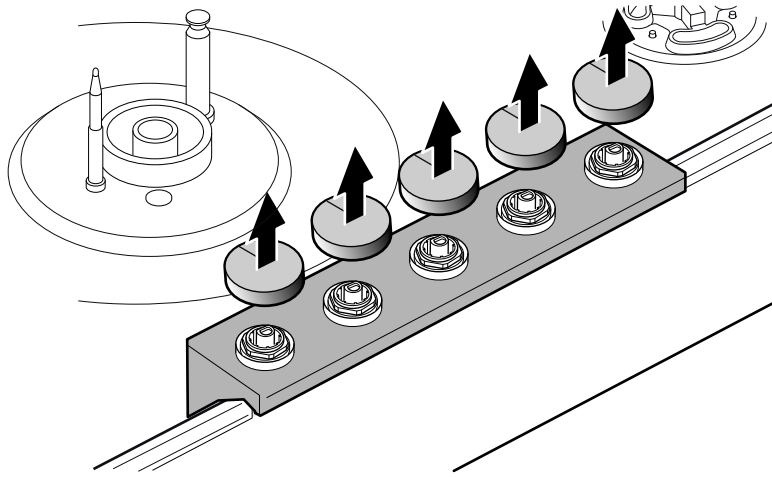

6

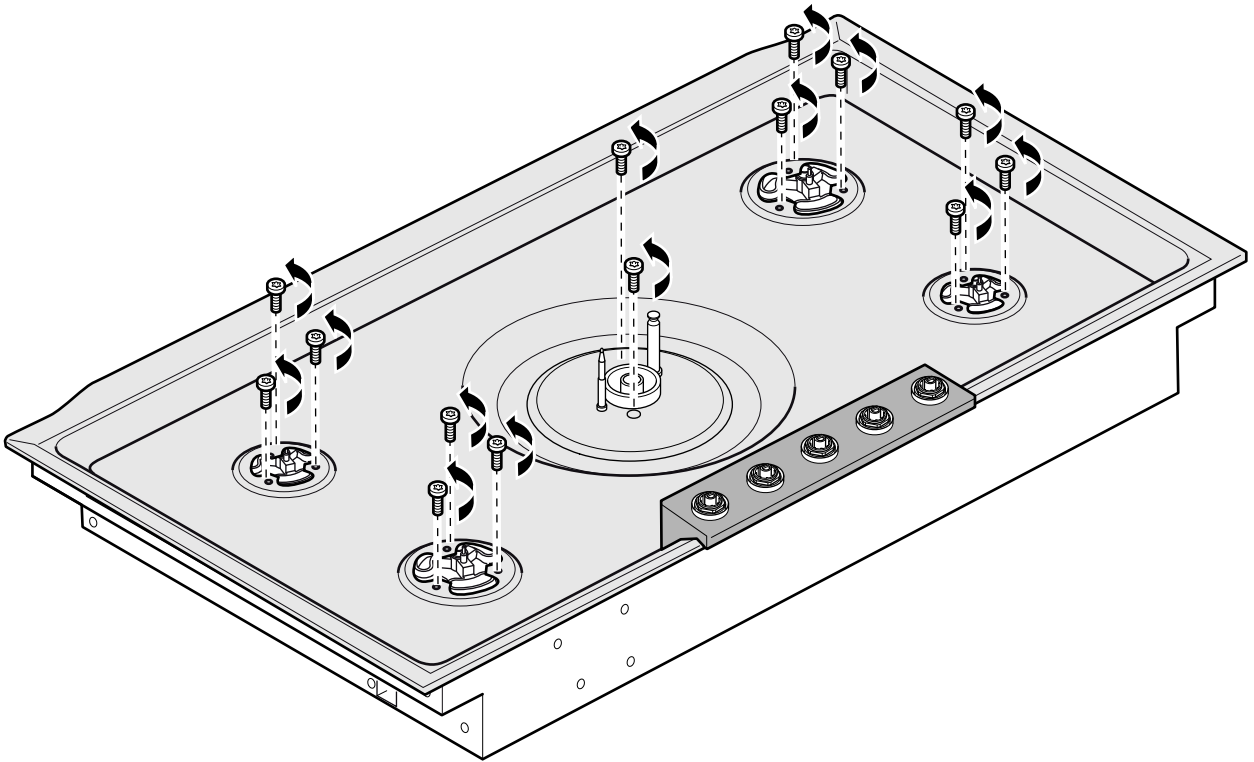

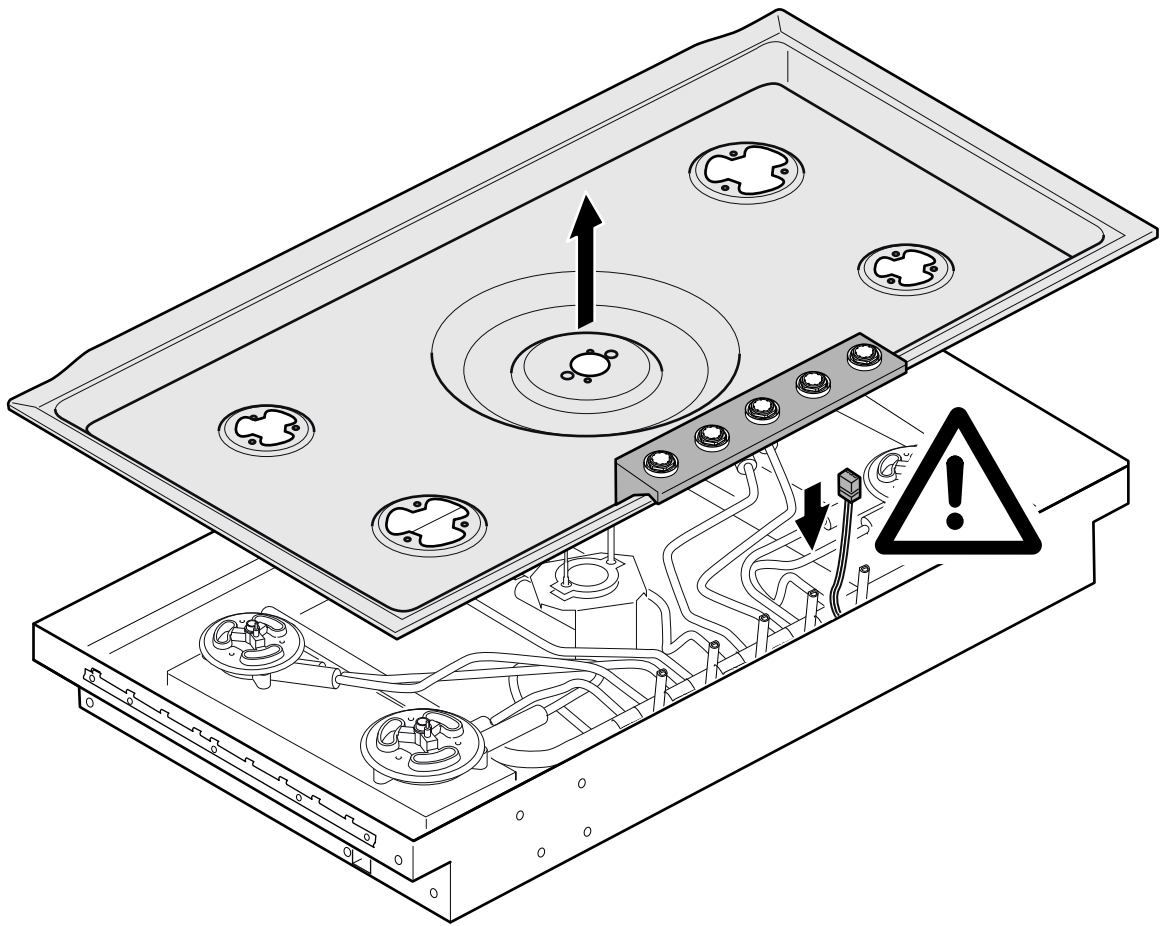

7



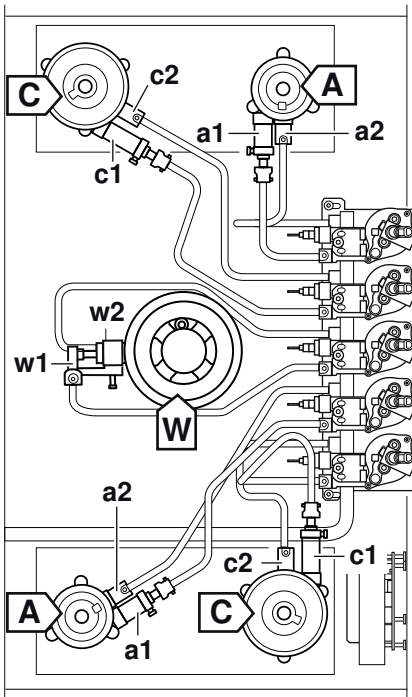
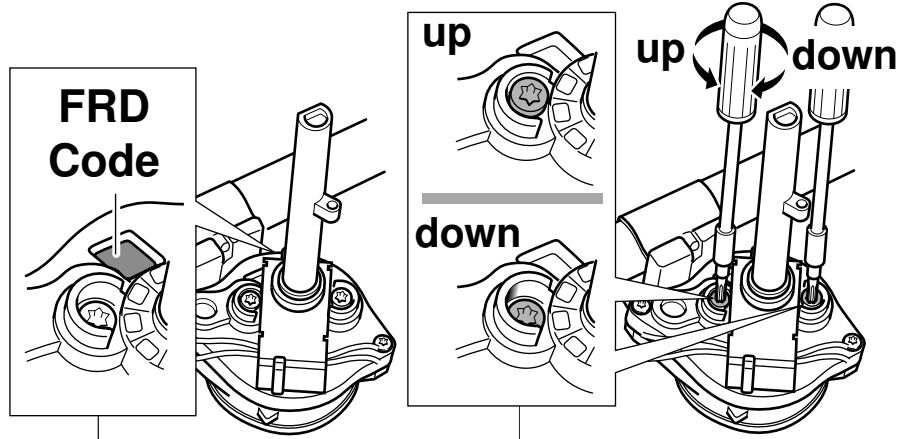

8



A	a1 	L1	a2 	L2	FRD-Code	M	Qn
NG 1.0 kPa	113	4 mm	42	open	KX	up	7.2 MJ/h (2 kW)
ULPG 2.75 kPa	68	6 mm	29	open	KX	down	7.2 MJ/h (2 kW)

C	c1 	L1	c2 	L2	FRD-Code	M	Qn
NG 1.0 kPa	168	6 mm	42	open	KY	up	14.4 MJ/h (4 kW)
ULPG 2.75 kPa	105	2 mm	29	open	KY	down	15.2 MJ/h (4.2 kW)

W	w1 	L	w2 	FRD-Code	M	Qn
NG 1.0 kPa	195	0 mm	67	KZ	up	18 MJ/h (5 kW)
ULPG 2.75 kPa	110A	0 mm	42	KZ	down	18 MJ/h (5 kW)

9

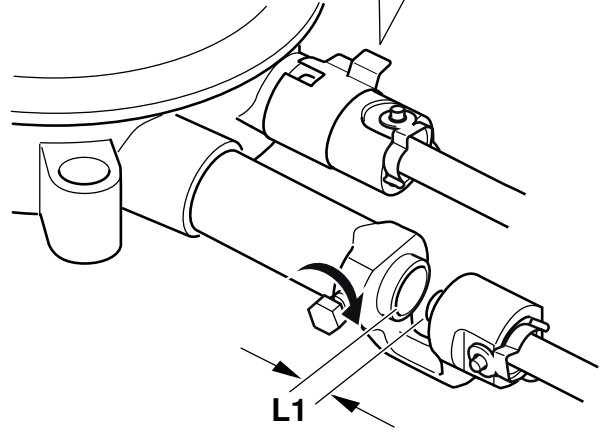
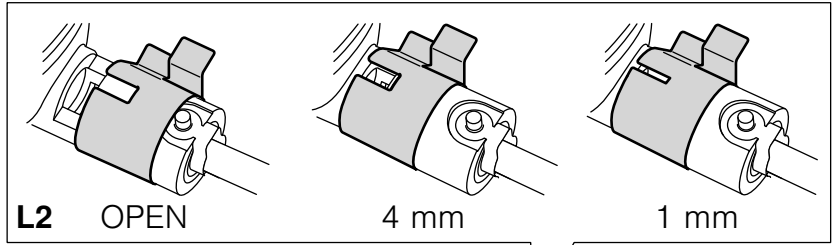
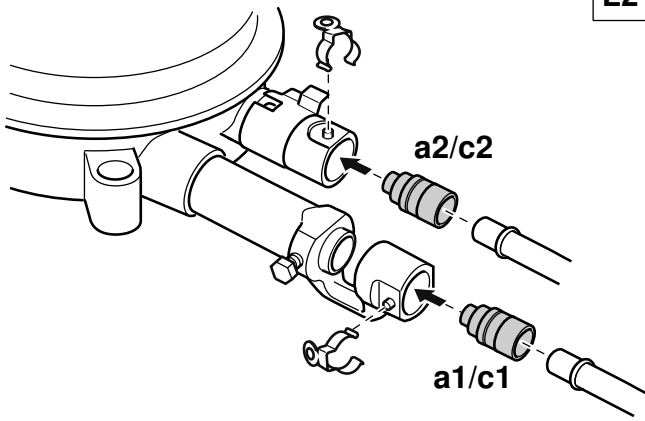

10



L	-1	-2	6
I	9	8	16

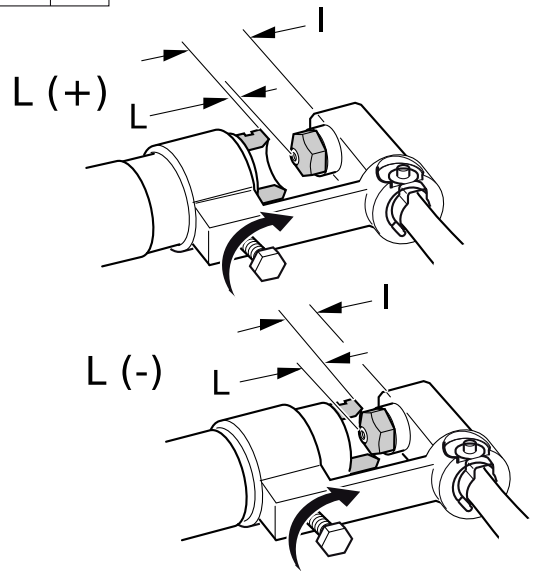
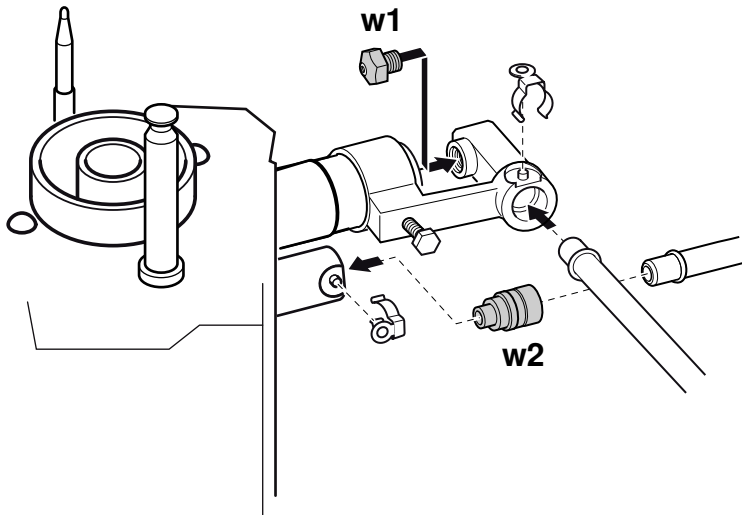

11

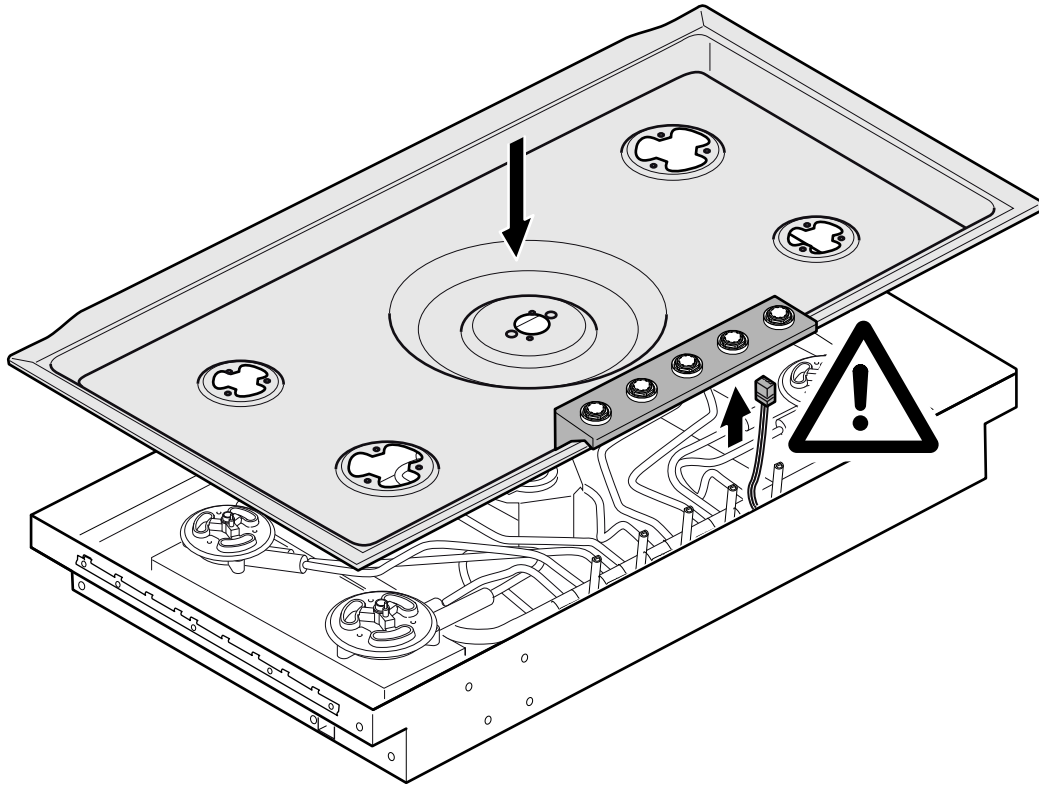

12

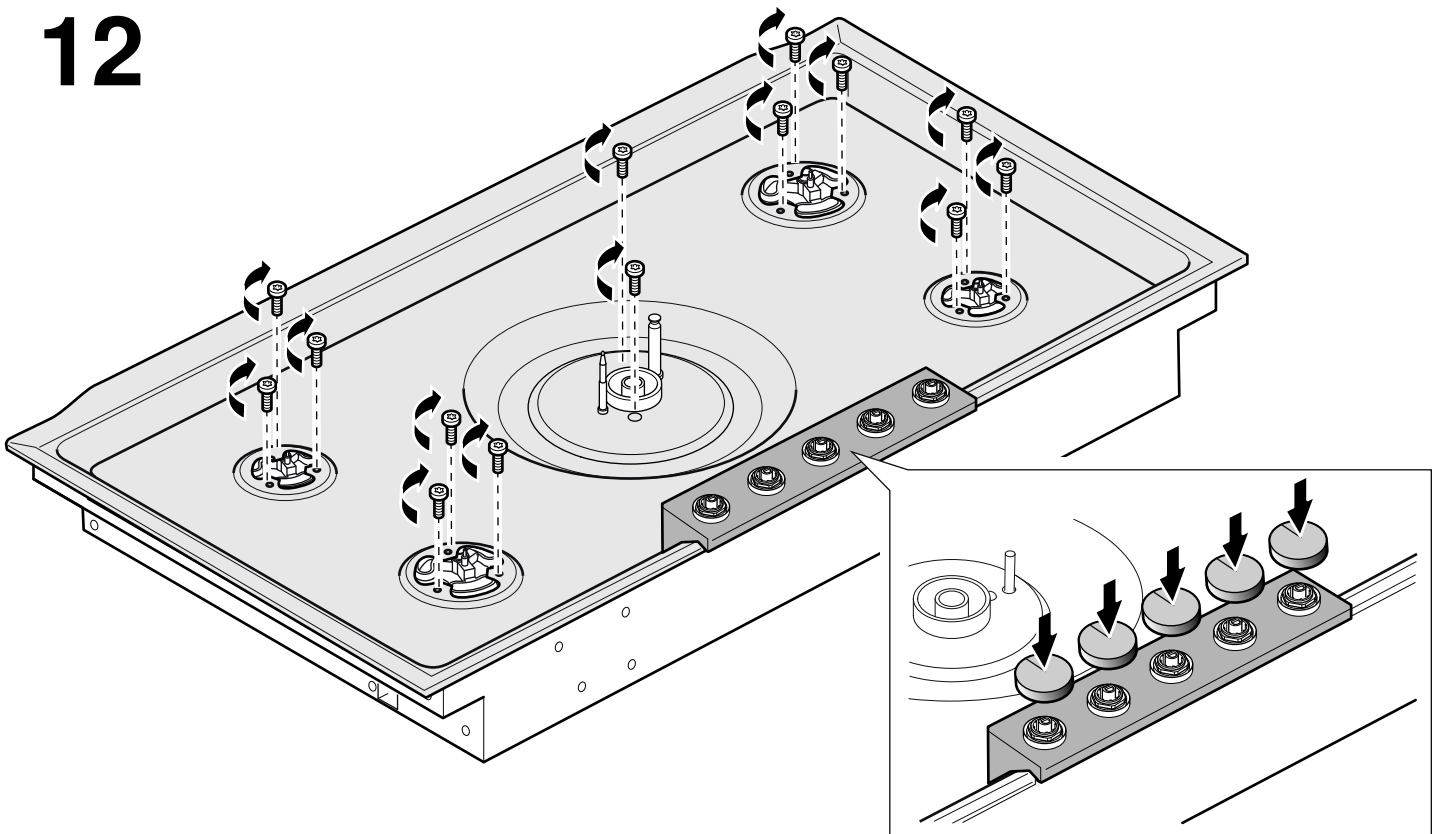

The reproduction, transmission or use of this document or its contents is not permitted without express written authority. Offenders will be liable for damages. All rights including copyright reserved. Copyright reserved.

Intended changes opposing release specimen or specification offer must be advised in time and may only be introduced following written clearance. Deviating designs will be refused.

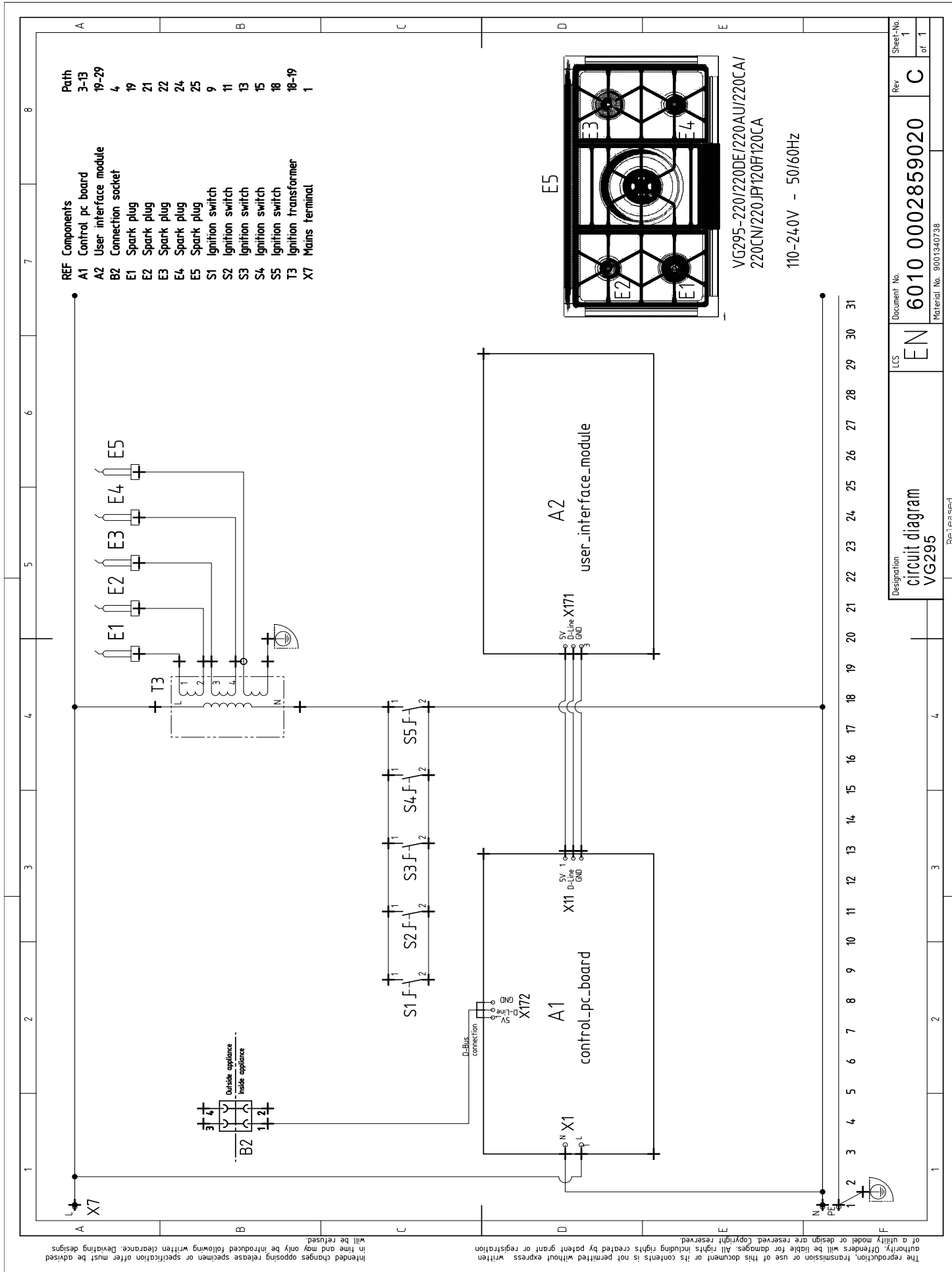

REF	Components	Path
A1	Control pc board	3-13
A2	User interface module	19-29
B2	Connection socket	4
E1	Spark plug	19
E2	Spark plug	21
E3	Spark plug	22
E4	Spark plug	24
E5	Spark plug	25
S1	Ignition switch	9
S2	Ignition switch	11
S3	Ignition switch	13
S4	Ignition switch	15
S5	Ignition switch	18
T3	Ignition transformer	18-19
X7	Mains terminal	1

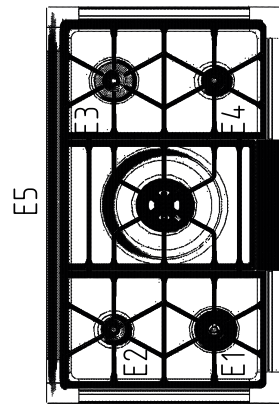

VG295-220/220DE/220AU/220CA/
220CN/220JP/220F/220CA
110-240V - 50/60Hz

Designation	LCS	Document No.	Rev	Sheet-No.
VG295	EN	6010 0002859020	C	1
				of 1
				Material No. 9001340738

Released

Important notes

Read these instructions carefully and keep them in a safe place. Safety during use can only be ensured if the appliance is fitted correctly according to these installation instructions. The installer is responsible for ensuring that the appliance operates perfectly at the point of installation.

The appliance must be connected to the mains only by an authorised person.

Before carrying out any type of work, turn off the electricity and gas supply.

Don't Risk Your Appliance Warranty

Only a licensed person will give you a compliance certificate, showing that the work complies with all the relevant standards. And only a licensed person will have insurance protecting their workmanship for 6 years. So make sure you use a licensed person to install this appliance and ask for your compliance certificate to ensure the manufacturer's appliance warranty will be honoured.

Statutory regulations

This appliance shall be installed in accordance with the manufacturer's installation instructions, local gas fitting regulations, municipal building codes, electrical wiring regulations and AS/NZS 5601.1 the Australian Standard for gas installations. Refer also to AS/NZS 5601.1 for pipe sizing tables.

Before connecting the appliance, please check whether the local connection conditions such as the gas type, gas pressure and mains voltage and the appliance settings are correct. Refer to the data plate located on the hob base for the necessary information.

Your new cooker is protected by suitable packaging whilst it was on its way to you. All materials used for this purpose are suitable for recycling. Please make a contribution to protecting the environment by disposing of the packaging accordingly.

For conversion to another type of gas, please call the after-sales service.

⚠ Risk of gas escape!

After connecting the appliance to the gas supply, always check the connection for leak tightness. The manufacturer accepts no responsibility for the escape of gas from a gas connection which has been previously tampered with.

Ensure sufficient air exchange in the room where the appliance is installed. Up to 11 kW total output:

- Minimum volume of the room where appliance is installed: 20 m³
- A door leading to the open air or a window which can be opened.

Up to 18 kW total output:

- Minimum volume of the room where appliance is installed: 2 m³ per kW total output.
- A door leading to the open air or a window which can be opened.
- An extraction hood into the open air. Minimum displacement volume of extraction hood: 15 m³/h per kW total output.

The installation system must incorporate an all-pin isolating switch with a contact opening of at least 3 mm, or the appliance should be connected to the mains via a safety plug. The plug must remain accessible after installation is complete.

Do not kink or trap the mains connection cable.

The appliance must be fitted according to the installation drawing. A minimum clearance of **260 mm** from the periphery of the burner to a rear or side horizontal combustible surface must be maintained. **If clearance is less than 260 mm** then that surface must be non-combustible or be protected in accordance with AS/NZS 5601.1 clause 6.10.1.2

Overhead clearances

Rangehoods and exhaust fans shall be installed in accordance with the manufacturers instructions. However, in no case shall the clearance between the highest part of the burner and the underside of the rangehood be less than **700 mm**.

This appliance is not intended for operation with an external timer or an external remote control.

THIS APPLIANCE IS NOT TO BE INSTALLED IN MARINE CRAFT OR CARAVANS.

THIS APPLIANCE IS NOT SUITABLE FOR USE IN MARINE CRAFT OR MOBILE HOMES.

Preparing the units (Fig. 1)

The fitted unit must be heat-resistant up to 90 °C. The fitted unit must still be sturdy after the cut-outs have been made.

Make the cut-out in the worktop as shown in the installation drawing. The angle between the cut surface and the worktop must be 90°.

The cut-out edges at the sides must be at least 20 mm thick and flat to ensure that the retaining springs sit correctly on the appliance. For laminate worktops, it may be necessary to secure strips at the sides in the cut-out.

After making the cut-outs, remove any shavings. Seal cut surfaces with heat-resistant and waterproof material.

Observe the minimum clearance of 10 mm between the bottom of the appliance and unit parts.

Use suitable supporting structural measures beneath the worktop, especially if the worktop is not very thick, to ensure that it is both robust and capable of bearing the required load. Take into account the weight of the appliance and any additional loads. The reinforcing material used must be heat- and moisture-resistant.

To improve flame stability, we recommend installing an intermediate floor underneath the appliance in the installation cabinet.

Fitting the appliance

Insert the appliance evenly into the cut-out. Push it down firmly into the cut-out.

Note: The appliance must sit securely in the cut-out and must not be able to move around (e.g. during cleaning). If the width of the cut-out is at the upper tolerance limit, secure batten to the sides of the cut-out if necessary.

Removing the appliance

Disconnect the appliance from the power and the gas supply. Push out the appliance from below.

Caution!

Risk of damage! Do not lever out the appliance from above.

Gas connection

The supply connection point shall be accessible with the appliance installed.

Using the R $\frac{1}{2}$ " (for appliance side) connection elbow provided, connect the appliance with the associated gasket to a fixed connection pipe. For natural gas the regulator must be connected.

If using a flexible connection

This appliance is approved for connection by a CLASS B hose. Connection is in compliance with AS/NZS 5601.1

There are two ways to carry out the connection to the main gas line:

- A: The hotplate can be connected with rigid pipe.
- B: Flexible Hose: If installing with a hose assembly, install with a hose assembly that complies with AS/NZS 1869, 10 mm ID, class Bor D, no more than 1.2 m long and in accordance with AS/NZS 5601.1. Ensure that the hose does not contact the hot surfaces of the hotplate, oven, dishwasher or any other appliance that may be installed underneath or next to the hotplate. The hose should not be subjected to abrasion, kinking or permanent deformation and should be inspected along its entire length with the cooktop in the installed position. Unions compatible with the hose fittings must be used and all connections tested for gas leaks.

Before leaving - check all connections for gas leaks with soap and water. **DO NOT** use a naked flame for detecting leaks. Ignite all burners both individually and concurrently to ensure correct operation of gas valves, burners and ignition. Turn gas taps to low position and observe stability of the flame for each burner individually and all together.

Adhere the duplicate data plate to an accessible location near to the cook top. When satisfied with the cook top, please instruct the user on the correct method of operation. In case the appliance fails to operate correctly after all checks have been carried out, refer to the authorised service provider in your area.

Electrical connection

Check that the appliance has the same voltage and frequency as the electrical installation system.

The hob is delivered with a mains cable and 3 pin moulded plug.

Only connect the appliance to sockets which have been fitted and earthed according to regulations.

The appliance corresponds to type Y: the mains connection cable must only be replaced by the after-sales service. Check the cable type and minimum cross section.

Technical data

Total connected load VG295220AU:

61.2 MJ/h (17 kW)

Electric 10.0 W

Changing the gas type

The appliance must only be converted to a different type of gas by a licensed expert.

Switch off the power supply and shut off the gas supply before carrying out conversion.

The gas hob belongs to the categories stated on the rating plate. The appliance can be converted to any other type of gas listed there using a conversion kit.

The gas type is changed by:

- Replacing the main nozzles
- Adjusting the gas valves (bypass screws)

The table shows the right combination for the relevant gas type.

Never remove the gas valve shaft. In the event of damage or unusual gas conversion, the entire gas valve must be replaced. Call the after-sales service.

Replacing the main nozzles in the standard burner and high output burner

1. Remove the pan supports and all burner parts.
2. Undo the fastening screws on the cooktop. Carefully lift up and remove the cooktop and disconnect the connection cable on the back of the control panel.
3. Remove the securing clips from the burner pipes. Pull out the burner pipes. The electrode can remain connected. Unscrew the burners (Torx T20) and pull out the burner pipes.
4. Pull the nozzles off the burner pipes by hand and remove the O-ring.
5. Check that the O-ring is seated correctly in the new main nozzles. Fit the nozzles to the burner pipes. Take care not to bend the burner pipes when doing so.
6. Fit the burners onto the burner pipes. Fit the securing clips. Screw the burners tightly into place.
7. Loosen the screw and then adjust the air regulating sleeve on the outer burner to the correct setting (see nozzle table – L1). Retighten the screw.
8. Adjust the air regulating sleeve on the inner burner to the correct setting by turning or pushing it (see nozzle table – L2).

Replacing the main control nozzles: Wok burner

1. Remove the securing clips from the burner pipes. Pull out the burner pipes. Unscrew the screw on the air regulating sleeve. Remove the nozzle retaining head.
2. Pull off the nozzle and O-ring for the inner burner ring by hand. Unscrew the nozzle for the outer burner ring (WAF 10).
3. Check that the O-ring is seated correctly in the new main nozzle for the burner inner ring. Fit the nozzle onto the burner pipe. Screw the new main nozzle for the outer burner ring as far as it will go into the nozzle retaining head.
4. Fit the nozzle retaining head and burner pipes. Fit the securing clips.
5. Loosen the screw and then adjust the air regulating sleeve to the correct setting (see nozzle table). Retighten the screw.

Adjusting the gas valves

⚠ Risk of damage!

Do not over-tighten the bypass screws.

If necessary, adjust the bypass screws **M** using a Torx screwdriver (see table):

up: The bypass screws must be flush with the top edge of the frame.

down: The bypass screws must be screwed in fully.

Assembly

1. Connect the connection cable on the back of the control panel.
2. Put the cooktop in place and tighten the screws evenly.
3. Put the burner parts and pan support in place, making sure they are positioned correctly.
4. Attach the control knobs.

Check that the appliance is working after conversion:

Yellow tips must not be visible on the flames. When turning the control knob quickly between the highest and the lowest setting, the burner must not go out and flashback must not occur.

Note: Attach the sticker showing the new gas type next to the rating plate on the appliance.

