

VG 295 220 AU

Gas hob

Table of contents

Intended use	3
Important safety information	4
Causes of damage	6
Environmental protection	6
Saving energy	6
Environmentally-friendly disposal	6
Familiarising yourself with your appliance	7
Gas hob	7
Visual signals of the luminous disc	7
Special accessories	7
Individual parts of the burners	8
Individual parts of the wok burner	8
Operating the appliance	9
Switching on	9
Switching on manually	9
Thermoelectric flame monitoring	10
Switching off	10
Residual heat indicator	10
Table of settings and tips	11
Tips for cooking and roasting	11
Tips for using a wok	11
Information and tips regarding cookware	12
Suitable cooking vessels	12
Precautions for use	12
Cleaning and maintenance	13
Cleaning the appliance	13
Burnt-on dirt	13
Burner discolouration	14
Trouble shooting	14
After-sales service	15
E number and FD number	15

Additional information on products, accessories, replacement parts and services can be found at www.gaggenau.com and in the online shop www.gaggenau.com/zz/store

Intended use

Read these instructions carefully. Only then will you be able to operate your appliance safely and correctly. Retain the instruction manual and installation instructions for future use or for subsequent owners.

This appliance is only intended to be fully fitted in a kitchen. Observe the special installation instructions.

This appliance must be installed according to the installation instructions included.

Check the appliance for damage after unpacking it. Do not connect the appliance if it has been damaged in transport.

Only allow a licensed professional to connect the appliance. Damage caused by incorrect connection is not covered under warranty. Call the after-sales service if you want to convert your appliance to a different type of gas.

This appliance is intended for domestic use and the household environment only. This appliance must only be used to prepare food and drinks and must never be used as a heater. Do not leave the appliance unattended during operation. Only use the appliance indoors.

Do not install this appliance on boats or in vehicles.

This appliance is intended for use up to a maximum height of 4000 metres above sea level.

This appliance is not intended for operation with an external clock timer or a remote control.

Do not use covers. These can cause accidents, for example due to overheating, catching fire or materials shattering.

Only use safety devices or child protection grilles approved by ourselves. Unsuitable safety devices or child protection grilles may result in accidents.

This appliance is not intended for use by persons (including children) with reduced physical, sensory or mental capabilities or lack of experience and knowledge, unless they have been given supervision or instruction concerning use of the appliance by a person responsible for their safety. Children should be supervised to ensure that they do not play with the appliance.

Close the safety valve on the gas supply line if the cooker will not be used for a prolonged period.

⚠ Important safety information

PLEASE READ THIS MANUAL BEFORE INSTALLING AND USING THIS COOKTOP.

This cooker is approved for use with Natural and Propane gases. Leave instructions with the owner.

DO NOT MODIFY THIS APPLIANCE.

DO NOT USE OR STORE FLAMMABLE MATERIALS IN THE APPLIANCE STORAGE DRAWER OR NEAR THE APPLIANCE.

DO NOT USE THIS APPLIANCE AS A SPACE HEATER.

THIS APPLIANCE IS NOT TO BE INSTALLED IN MARINE CRAFT OR CARAVANS.

Do not use this cooker in freezing conditions.

⚠ Warning – WHAT TO DO IF YOU SMELL GAS!

Escaping gas may cause an explosion.

If you smell gas or notice any faults in the gas installation:

- Do not light any appliance.
- Do not touch any electrical switch; do not use any phone in the building.
- Immediately call your gas supplier from a neighbour's phone. Follow the gas supplier's instructions.
- If you cannot reach your gas supplier, call the fire department.

⚠ Warning – Risk of asphyxiation!

The use of a gas cooker leads to a build-up of heat, moisture and products of combustion in the room where the appliance is installed. Ensure that the installation room is well ventilated. The natural ventilation openings must be kept open or a mechanical ventilation device must be provided (e.g. an extractor hood). Intensive and persistent use of the appliance may mean that it is necessary to have additional ventilation (e.g. opening a window), or more effective ventilation (e.g. operating the existing mechanical ventilation device at a higher setting).

⚠ Warning – Risk of fire!

- Hot oil and fat can ignite very quickly. Never leave hot fat or oil unattended. Never use water to put out burning oil or fat. Switch off the hotplate. Extinguish flames carefully using a lid, fire blanket or something similar.
- The hotplates become very hot. Never place combustible items on the hob. Never place objects on the hob.
- The appliance becomes very hot and flammable materials could catch fire. Never store or use flammable objects (e.g. spray cans, cleaning agents) under the appliance or in its immediate vicinity. Never place flammable items on or in the appliance.
- When gas hotplates are in operation without any cookware placed on them, they can build up a lot of heat. The appliance and the extractor hood above it may become damaged or be set on fire. Grease residue in the filter of the extractor hood may ignite. Only operate the gas burners with cookware on them.

- If the burner does not ignite after 15 seconds, switch off the control knob and open the door or window in the room. Wait at least 1 minute before igniting the burner again.

⚠ Warning – Risk of burns!

- The appliance becomes hot during operation. Allow the appliance to cool down before cleaning.
- The hotplates and surrounding area (particularly the hob surround, if fitted) become very hot. Never touch the hot surfaces. Keep children at a safe distance.
- The accessible parts become very hot when in operation. Never touch hot parts. Keep children at a safe distance.
- When the appliance cover is closed, heat will accumulate. Only close the appliance cover when the appliance has cooled down. Never switch the appliance on with the appliance cover closed. Do not rest food on the appliance cover or use it to keep food warm.
- Empty cookware becomes extremely hot when set on a gas hotplate that is in operation. Never heat up empty cookware.
- If the liquefied gas bottle is not upright, liquefied propane/butane can enter the appliance. Intense darting flames may therefore escape from the burners. Components may become damaged and start to leak over time so that gas escapes uncontrollably. Both can cause burns. Always use liquefied gas bottles in an upright position.

⚠ Warning – Risk of injury!

- Incorrect repairs are dangerous. Repairs may only be carried out, and damaged power and gas lines replaced, by an after-sales engineer trained by us. If the appliance is faulty, unplug the mains plug or switch off the fuse in the fuse box. Shut off the gas supply. Contact the after-sales service.
- Faults or damage to the appliance are dangerous. Never switch on a faulty appliance. Unplug the appliance from the mains or switch off the circuit breaker in the fuse box. Shut off the gas supply. Contact the after-sales service.
- Unsuitable pan sizes, damaged or incorrectly positioned pans can cause serious injury. Observe the instructions which accompany the cookware.

⚠ Warning – Risk of electric shock and serious injury!

- The cable insulation on electrical appliances may melt when touching hot parts of the appliance. Never bring electrical appliance cables into contact with hot parts of the appliance.
- Do not use any high-pressure cleaners or steam cleaners, which can result in an electric shock.
- A defective appliance may cause electric shock. Never switch on a defective appliance. Unplug the appliance from the mains or switch off the circuit breaker in the fuse box. Contact the after-sales service.
- Incorrect repairs are dangerous. Repairs may only be carried out by one of our trained after-sales engineers. If the appliance is faulty, unplug the mains plug or switch off the fuse in the fuse box. Contact the after-sales service.

Causes of damage

Caution!

- **Risk of heat damage to adjacent appliances or kitchen units:** If the appliance is in operation for an extended period, heat and moisture will be generated. Additional ventilation is required. Open the window or switch on an extractor hood that discharges the extracted air and moisture outside the building.
- **Risk of damage to the appliance due to the build-up of heat:** Do not heat roasters, frying pans or grill stones using more than one burner at a time.
- **Malfunction:** Always turn the control knob to the "Off" position when the appliance is not being used.

Environmental protection

The sections below list a number of energy-saving tips and provide information on disposing of your appliance.

Saving energy

- Choose a burner of roughly the same size as your pan. Place the cookware in the middle.
- Use small saucepans for small quantities. Using a large saucepan with little in it consumes a lot of energy.
- Always place suitable lids on saucepans. Cooking without a lid consumes significantly more energy. Use a glass lid so that you can see into the pan without having to lift the lid.
- Cook with only a little water. This will save energy and preserve the vitamins and minerals in vegetables.
- Switch to a lower heat setting in good time. This will save energy.

Environmentally-friendly disposal

Dispose of packaging in an environmentally-friendly manner.



This appliance is labelled in accordance with European Directive 2012/19/EU concerning used electrical and electronic appliances (waste electrical and electronic equipment - WEEE). The guideline determines the framework for the return and recycling of used appliances as applicable throughout the EU.

Familiarising yourself with your appliance

Gas hob

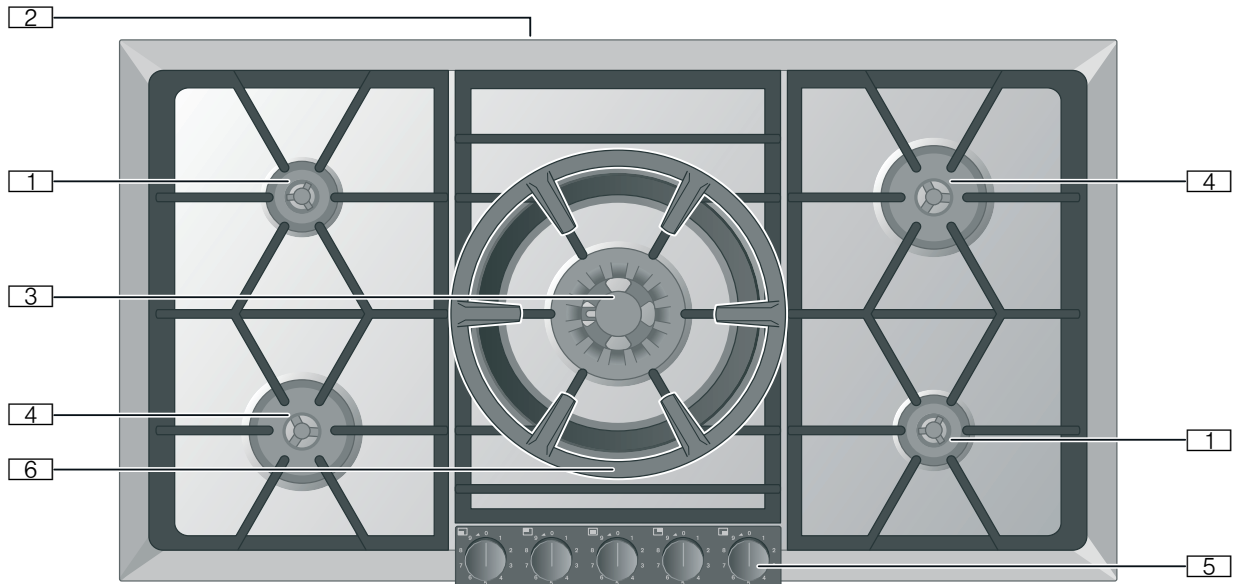

- 1 Standard output burner 7.2 MJ/h (2.0 kW)
- 2 Air inlet opening
- 3 Wok burner 18 MJ/h (5.0 kW)
- 4 High output burner 14.4 MJ/h (4.0 kW)
- 5 Control knob:
Power levels 1-9
◀ Control knob direction of rotation
- 6 Wok ring

Visual signals of the luminous disc

The control knob is encircled by an illuminated ring that indicates a number of statuses and functions.

Indicator/symbol	Meaning
○ Off	Appliance OFF
● Lit orange	Appliance ON
● Slow flashing orange	Appliance OFF Residual heat indicator
☀ Flashing orange	Appliance fault Call the after-sales service.

Special accessories

You can order the following special accessories from your specialist dealer:

WP 400 001 Wok made from multi-layer material. Features a domed bottom and handle, dia.: 36 cm, capacity: 6 litres, height: 10 cm.

Only use the accessories as specified. The manufacturer accepts no liability if these accessories are used incorrectly.

Individual parts of the burners

Ensure that the individual parts of the burners are fitted in the correct position and are straight; otherwise, this may result in ignition problems or problems during operation.

Fit the burner head and the burner ring in such a way that the latches on the lower section of the burner click into place in the corresponding slots. The alignment of the burner head and the burner ring is not important.

Note: If the burner parts are fitted at an angle, the appliance will not work.

Individual parts of the standard output burner and high output burner

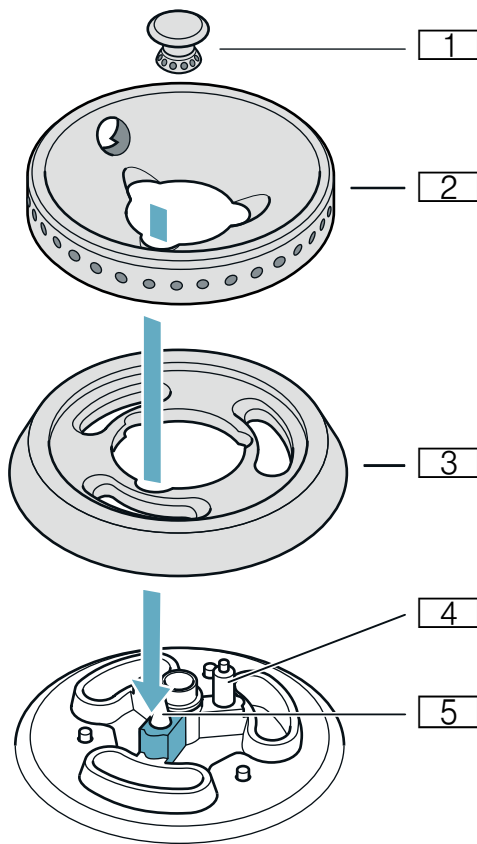

- 1 Burner cap
- 2 Burner ring
- 3 Burner head
- 4 Ignition plug
- 5 Thermocouple

Individual parts of the wok burner

Ensure that the individual parts of the wok burner are fitted in the correct position and are straight; otherwise, this may result in ignition problems or problems during operation. Fit the burner head such that the thermocouple is positioned in the corresponding recess on the burner head. The lug on the burner ring must engage in the corresponding recess on the burner head.

Note: If the burner parts are fitted at an angle, the appliance will not work.

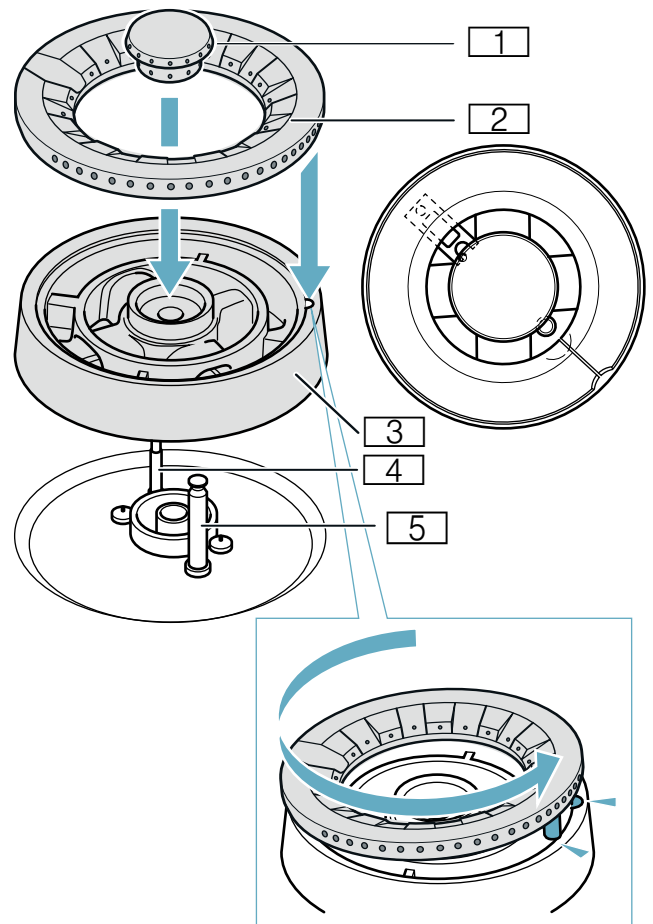

- 1 Burner cap
- 2 Burner ring
- 3 Burner head
- 4 Thermocouple
- 5 Ignition plug

Operating the appliance

Notes

- Only use the accessories specified. Do not line the stainless steel recess (e.g. with aluminium foil).
- Do not cover the ventilation openings on the back of the control panel.
- The burner and ignition plug must be clean and dry.
- Only light the burners if the pan supports and all burner parts are correctly fitted.
- To ignite a burner, firmly press the control knob down as far as possible and hold it there, then turn it to the required position.
- Once ignited, press and hold the control knob for approx. 2 to 4 seconds to enable the heat sensor that opens the gas flow to heat up first.
- If the flame does not ignite within 2 to 4 seconds, turn the control knob anti-clockwise to the lowest setting and, once ignited, turn it back to the highest setting. It can often be quicker to ignite the burner in the lowest setting because different gases have different ignition characteristics.
- When one burner is ignited, an ignition spark will also be generated at all the other burners.
- Do not touch the ignition plug while the gas appliance is being lit.
- It is important to keep the appliance clean. If the ignition plugs are dirty, this may cause ignition problems. Clean the ignition plugs regularly with a small, non-metallic brush. Take care to prevent the ignition plugs from suffering any heavy knocks.

Abnormal operation

Flames are usually blue and sharply defined. If the flames are yellowish or noisy or if the gas does not ignite within the period specified under "switching on" abnormal operation is indicated. Refer to chapter "After-sales service" of this manual for service contact details.

Switching on

This appliance is equipped with a step valve. The markings on the control knob show you the output from power levels from 1 to 9.

Your gas hob comes with ignition plugs for electrical ignition.

- 1 Place a suitable item of cookware on the pan support.
- 2 Push in the control knob for your chosen burner and turn it anticlockwise to the power level you require.
The burner ignites automatically.

Turn the control knob to set the power level.

Caution!

Damage to the appliance

Never try to turn the control knob directly from position 0 to position 1, or from position 1 directly to position 0. Doing this will damage the step valve.

⚠ Warning – Risk of deflagration!

If the burner does not ignite after 15 seconds, switch off the control knob and open the door or window in the room. Wait at least 1 minute before igniting the burner again.

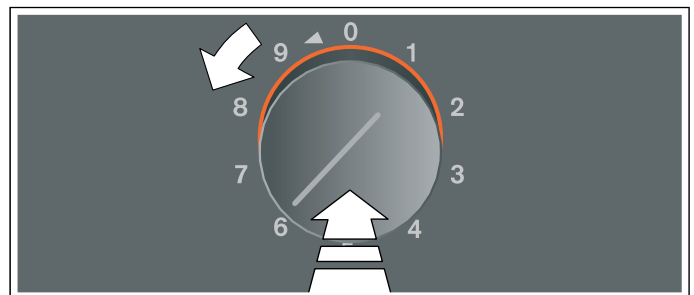

Switching on manually

During a power cut you can ignite the burners manually.

- 1 Place a suitable pot or pan on the pot grid.
- 2 Press the corresponding control knob and turn it anticlockwise to the required setting. Keep the control knob pressed.
- 3 Use a gas lighter or a match to ignite the burner. Keep the control knob pressed for a few seconds after ignition.

Note: The indicator on the illuminated ring remains off.

Thermoelectric flame monitoring

For your safety, the hob is fitted with thermoelectric flame monitoring. This prevents the flow of gas if the burner accidentally goes out while it is in use (e.g. due to draughts).

If the burner accidentally goes out while it is in use, turn the control knob to the 0 position and wait at least one minute before you ignite the burner again.

Switching off

Turn the control knob clockwise to position 0.

Warning – Risk of burns!

When the appliance cover is closed, heat will accumulate. Only close the appliance cover when the appliance has cooled down. Never switch the appliance on with the appliance cover closed. Do not rest food on the appliance cover or use it to keep food warm.

Residual heat indicator

After switching off the appliance, the illuminated ring on the control knob slowly flashes orange until the appliance has cooled enough for it to be safe to touch. Do not touch the appliance while the residual heat indicator is flashing.

Table of settings and tips

Power level	Cooking method	Examples
9	Heating	Water, clear soups
	Blanching	Vegetables
	Deep-frying	Chips, pastries
7 - 9	Searing	Meat
	Frying at high temperatures	Meat, potatoes
6 - 8	Simmering with the lid open	Liquids, dough-based foods
5 - 7	Baking	Flour-based food
	Frying at medium temperatures	Poultry, fish
4 - 5	Frying at low temperatures	Fried sausages, onions, egg dishes
	Defrosting	Frozen food
4	Poaching with the lid open	Dumplings, boiled sausages
	Warming	Vegetables, soups, stews
3 - 4	Braising	Beef olives, joints
	Stewing	Vegetables
2 - 4	Simmering with the lid on	Soups, vegetables
1	Soaking	Rice, rice pudding, cereals

Tips for cooking and roasting

The values given in the settings table must be looked upon as recommended values. The heat required depends not only on the type and condition of the food, but also the size and contents of the pot.

Due to the high performance of the cooktop, fat and oil will heat up quickly. Never leave the cooktop unattended, fat can ignite, food can burn.

Tips for using a wok

Note: When you cook using a wok, place the wok ring onto the pan support over the wok burner. Make sure that the wok is stable on the wok ring when you are cooking.

We recommend using woks with a domed base. You can order a high-quality wok as an optional accessory (WP 400 001).

When cooking with the wok, use only cooking oil that is suitable for heating to high temperatures, such as groundnut oil.

Cook the ingredients at a high heat, while stirring constantly. Do not cook them for too long. The vegetables should be al dente.

For stirring the food and for taking it out of the pan, it is best to use a shallow ladle with a long handle made from a heat-resistant material.

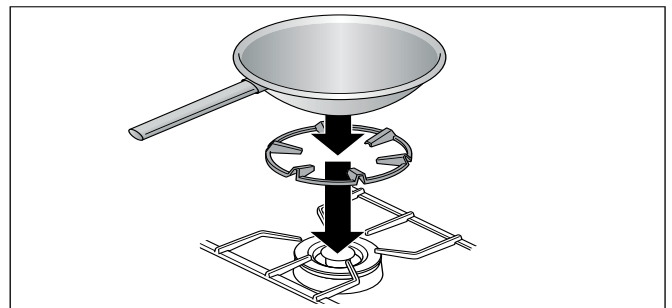

⚠ Warning – Risk of injury!

The standard-output burner and high-output burner are not suitable for use with the wok ring and a wok. The wok pan is not stable and may overturn. Never place the wok ring on the standard-output burner or high-output burner.

Information and tips regarding cookware

The following information and tips have been provided to help you save energy and avoid damaging your cookware.

Suitable cooking vessels

Burner	Pot base, recommended diameter	Pot base, minimum diameter
Standard burner	200 - 240 mm	90 mm
High output burner	240 - 280 mm	90 mm
Wok burner	240 - 320 mm	160 mm

Pots with a diameter of less than 90 mm or more than 280 mm (320 mm for the Wok burner) should not be used. When using large pots, pay attention to keeping to a minimum distance of 50 mm between the cooking vessel and combustible surroundings. A minimum distance of 50 mm must be observed between the control knob / control panel and the pot or pan. The pot or pan should not touch the control panel.

Precautions for use

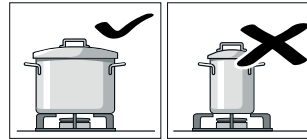

Use pots or pans which are the right size for each burner.

Do not use small pots or pans on large burners. The flame should not touch the sides of the pot.

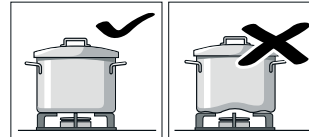

Do not use damaged pots or pans, which do not sit evenly on the cooktop, they may tip over.

Only use pots or pans with a thick, flat base.

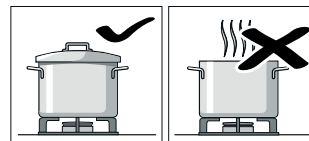

Do not cook without using a lid and make sure the lid is properly fitted. This wastes energy.

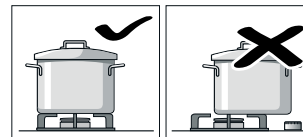

Always centre the pot or pan over the burner, otherwise it could tip over.

Do not place large pots on the burners near the control knobs. These may get damaged by the high temperatures.

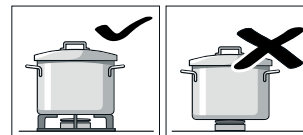

Place the pots or pans on the pan support, never directly on the burner.

Make sure that the pan supports and burner caps are correctly positioned before using the appliance.

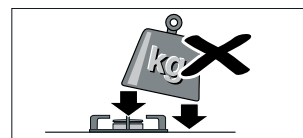

Pots or pans should be placed on the cooktop carefully.

Do not strike the cooktop and do not place excessive weight on it.

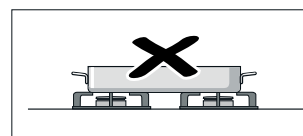

Do not heat a cooking vessel (e.g. roaster, pan, grill stone) on more than one burner at the same time. The resulting heat accumulation will damage the appliance.

Cleaning and maintenance

⚠ Warning – Risk of electric shock!

Do not use any high-pressure cleaners or steam cleaners, which can result in an electric shock.

⚠ Warning – Risk of burns!

The accessible parts become very hot when in operation. Never touch hot parts. Keep children at a safe distance.

Caution! Risk of surface damage

Do not use these cleaners

- harsh or abrasive cleaning agents
- oven cleaners
- corrosive or aggressive cleaners, or those containing chlorine
- cleaning agents with a high alcohol content
- hard and scratchy sponges, brushes or scouring pads

If such an agent comes into contact with the appliance, wash it off immediately with water.

Thoroughly wash out new sponge cloths before using them!

Cleaning the appliance

Clean the appliance after each use once it has cooled down. Remove liquids that have boiled over or spilled immediately and do not allow any food remains to burn on.

Dry the burners thoroughly after cleaning. Only operate the appliance when the burners are dry. Damp burners can cause ignition problems and/or an unstable flame.

During assembly, make sure that the burner parts (catch tappets) are in the correct position. All parts must be straight.

Appliance part/ surface	Recommended cleaning
Stainless steel surfaces	Use soapy water and dry with a soft cloth. Use a minimal amount of water when cleaning to prevent water from penetrating the appliance. Soak burnt-on remains with a small amount of soapy water; do not scour. Remove heavy soiling or yellow discoloration caused by heat using our stainless steel cleaner (item no. 00311499).
Pan supports, wok ring	Carefully remove for cleaning. Soak in the sink. Clean using a scrubbing brush and washing-up liquid. Clean the area around the rubber buffers carefully so that they do not become detached. Rinse with clean water and dry before putting them back. You can also clean the pan supports in the dishwasher. This may cause the pan support to become lighter in colour. This does not affect its usability.
Burner parts	Use soapy water and dry with a soft cloth. Make sure that the openings are not blocked. Make sure that no small parts are lost. Do not clean in the dishwasher.
Control panel	The soapy cloth must not be too wet. Dry with a soft cloth.
Control knobs	The soapy cloth must not be too wet. Dry with a soft cloth. Caution! Damage to the appliance Do not detach the control knobs to clean them.

Burnt-on dirt

For hard-to-remove, burnt-on dirt, you can order a cleaning gel from our online shop, from your specialist retailer or via our after-sales service (item number 00311859). It is suitable for pan supports and the stainless steel recess. If necessary, let the dirt soak overnight. Follow the instructions on the cleaning product.

Caution! Damage to the surface

Do not use the cleaning gel on the burner parts, the control panel or the control knobs.

Burner discolouration

After extended use, the brass burner parts take on a darker colour as a result of the oxidation process that occurs naturally. The discolouration does not affect their serviceability.

Trouble shooting

Warning – Risk of electric shock!

Incorrect repairs are dangerous. Repairs may only be carried out by one of our trained after-sales engineers. If the appliance is faulty, unplug the mains plug or switch off the fuse in the fuse box. Contact the after-sales service.

Faults often have simple explanations. Please read the information in the table before calling the after-sales service.

Fault	Possible cause	Solution
Malfunction of the general electrical system.	The household fuse has tripped.	Check the fuse box if the fuse has tripped.
The electric ignition does not work.	There may be food or cleaning products stuck between the ignition sparkers and the burners.	The space between the ignition sparker and the burner must be clean.
	The burners are wet.	Dry the burner caps carefully.
	The burner caps are not correctly positioned.	Check that the burner caps are correctly positioned.
The burner flame is not uniform.	Power cut	Ignite the burner with a lighter or a match.
	The burner components are not correctly positioned.	Ensure the components are correctly positioned.
The gas flow is not normal or there is no gas.	The grooves on the burner are dirty.	Clean the grooves on the burner.
	The gas supply is blocked via gas taps.	Open all gas taps.
The kitchen smells of gas.	If the gas is supplied from a gas cylinder, check that this is not empty.	Change the gas cylinder.
	There may be a leak in the gas cylinder coupling.	Check that the coupling is sound.
The burner goes off after ignition.	The control knob was not held down for long enough.	Once the burner is on, hold the control knob down a few seconds longer. Fully press control knob.
	The grooves on the burner are dirty.	Clean the grooves on the burner.

After-sales service

Our after-sales service is there for you if your appliance needs to be repaired. We will always find an appropriate solution, also in order to avoid after-sales personnel having to make unnecessary visits.

Servicing shall be carried out only by authorised personnel. **DO NOT MODIFY THIS APPLIANCE.**

E number and FD number

When calling us, please quote the full product number (E no.) and the production number (FD no.) so that we can provide you with the correct advice. The rating plate that features these numbers can be found on the underside of the appliance.

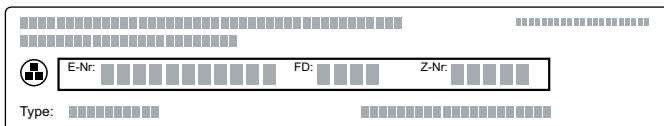

To save time, you can make a note of the numbers for your appliance and the telephone number of the after-sales service in the space below in case you need them.

E no.

FD no.

After-sales service

Please note that a visit from an after-sales service engineer is not free of charge in the event that the appliance has been misused, even during the warranty period.

Please find the contact data of all countries in the enclosed customer service list.

To book an engineer visit and product advice

GB 0344 892 8988
Calls charged at local or mobile rate.

IE 01450 2655
0.03 € per minute at peak.
Off peak 0.0088 € per minute.

AU 1300 368 339

NZ 09 477 0492

Trust the expertise of the manufacturer, and rest assured that the repair will be carried out by trained service technicians using original spare parts for your domestic appliance.

Gaggenau Hausgeräte GmbH
Carl-Wery-Straße 34
81739 München
GERMANY
www.gaggenau.com

9001408940 (981105)
en

GAGGENAU

