

**Gaggenau**

en User manual and installation instructions

# **VP414115**

Teppanyaki

# Table of contents

## INFORMATION FOR USE

1	<b>Safety</b> .....	2
2	<b>Preventing material damage</b> .....	3
3	<b>Environmental protection and saving energy</b> .....	3
4	<b>Familiarising yourself with your appliance</b> .....	4
5	<b>Before using for the first time</b> .....	4
6	<b>Basic operation</b> .....	5
7	<b>How it works</b> .....	5
8	<b>Cleaning and servicing</b> .....	7
9	<b>Troubleshooting</b> .....	8
10	<b>Customer Service</b> .....	9
11	<b>Disposal</b> .....	10
12	<b>INSTALLATION INSTRUCTIONS</b> .....	10
12.3	<b>General information</b> .....	10

## 1 Safety

Observe the following safety instructions.

### 1.1 General information

- Read this instruction manual carefully.
- Do not connect the appliance if it has been damaged in transit.

### 1.2 Intended use

Only use this appliance:

- To prepare meals and drinks.
- Under supervision. Never leave the appliance unattended when cooking for short periods.
- in private households and in enclosed spaces in a domestic environment.
- up to an altitude of max. 2000 m above sea level.

Do not use the appliance:

- On boats or in vehicles.
- as a room heater.
- With an external timer.

### 1.3 Restriction on user group

This appliance may be used by children aged 8 or over and by people who have reduced physical, sensory or mental abilities or inad-

equately experience and/or knowledge, provided that they are supervised or have been instructed on how to use the appliance safely and have understood the resulting dangers.

Do not let children play with the appliance. Children must not perform cleaning or user maintenance unless they are at least 15 years old and are being supervised.

Keep children under the age of 8 years away from the appliance and power cable.

### 1.4 Safe use

#### **WARNING – Risk of fire!**

Hot oil and fat ignites quickly.

- ▶ Never leave hot oil or fat unattended.
- ▶ Never attempt to extinguish a fire using water; instead, switch off the appliance and then cover the flames with a lid or a fire blanket, for example.

The appliance gets very hot and may cause flammable materials to ignite.

- ▶ Never store or use combustible materials (e.g. spray cans or cleaning agents) under the appliance or in its immediate vicinity.
- ▶ Never place flammable objects on or in the appliance.

#### **WARNING – Risk of burns!**

Hob protective grilles may cause accidents.

- ▶ Never use hob protective grilles.

#### **WARNING – Risk of scalding!**

The accessible parts of the appliance become hot during operation.

- ▶ Never touch these hot parts.
- ▶ Keep children at a safe distance.

#### **WARNING – Risk of burns!**

The appliance remains hot for a long time after it is switched off.

- ▶ Do not touch the appliance while the residual heat indicator is lit.

If the appliance cover is closed, this causes a build-up of heat.

- ▶ Only operate or switch on the appliance when the appliance cover is open.
- ▶ Do not use the appliance cover for keeping warm or setting down.
- ▶ Only close the appliance cover once the appliance has cooled down.

**⚠ WARNING – Risk of electric shock!**

The insulation on cables of electrical appliances may melt if it touches hot parts of the appliance.

- ▶ Never bring electrical appliance cables into contact with hot parts of the appliance.

An ingress of moisture may cause an electric shock.

- ▶ Do not use any steam cleaners or high-pressure cleaners to clean the appliance.

A defective appliance may cause an electric shock.

- ▶ Never switch on a defective appliance.
- ▶ Unplug the appliance from the mains or switch off the circuit breaker in the fuse box.
- ▶ Call customer service. → *Page 9*

Improper repairs are dangerous.

- ▶ Repairs to the appliance should only be carried out by trained specialist staff.
- ▶ Only use genuine spare parts when repairing the appliance.
- ▶ If the power cord or the appliance power cable of this appliance is damaged, it must be replaced with a special power cord or special appliance power cable, which is available from the manufacturer or its Customer Service.

**⚠ WARNING – Risk of injury!**

Heat accumulation occurs when the device cover is closed.

- ▶ Only close the appliance cover when the appliance has cooled down.
- ▶ Never switch the appliance on with the appliance cover closed.
- ▶ Do not rest food on the appliance cover or use it to keep food warm.
- ▶ Remove spilled liquids before opening the appliance cover.

## 2 Preventing material damage

**ATTENTION!**

Hard or pointed objects may cause scratches or notches to form on the frying surface.

- ▶ Do not allow any hard or pointed objects to fall onto the frying surface.
- ▶ Never cut on the frying surface with a knife.
- ▶ Use the spatula supplied to turn the food.

- ▶ Never hit the frying surface with the spatula. Non heat-resistant materials will melt on heated hot-plates.

- ▶ Do not use oven protective foil.
- ▶ Do not use aluminium foil or plastic containers. Liquids may damage the appliance.
- ▶ Remove spilled liquids before opening the appliance cover.

## 3 Environmental protection and saving energy

### 3.1 Saving energy

If you follow these instructions, your appliance will use less energy.

Stop preheating the appliance once it reaches the required temperature.

- An extended preheating time increases the energy consumption.

Use the edge of the frying surface to keep food that is already cooked warm, whilst continuing to cook food in the middle.

- This enables you to use the heat distribution of the frying surface efficiently.

Switch back to a lower temperature early on.

- Using a temperature that is too high wastes energy.

Select an appropriate temperature.

- Using a temperature that is too high wastes energy.

Use the residual heat of the Teppan Yaki. If the cooking time is relatively long, you can switch the appliance off 5 to 10 minutes before the cooking time ends.

- Failing to make the most of any residual heat leads to increased energy consumption.

Product Information according (EU) 66/2014 can be found on the attached appliance pass and online on the product page for your appliance.

### 3.2 Disposing of packaging

The packaging materials are environmentally compatible and can be recycled.

- ▶ Sort the individual components by type and dispose of them separately.

## 4 Familiarising yourself with your appliance

### 4.1 Appliance

You can find an overview of the parts of your appliance here.

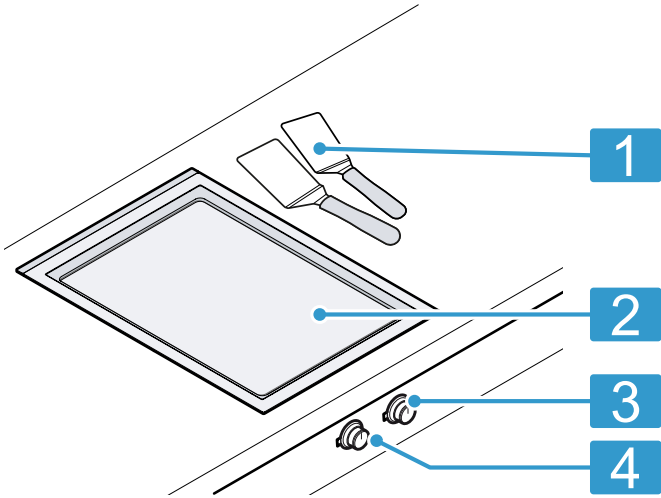

- |   |                                      |
|---|--------------------------------------|
| 1 | Spatula, 2 pcs, for turning the food |
| 2 | Frying surface                       |
| 3 | Temperature setting                  |
| 4 | Selecting the cooking zone           |

### 4.2 Control knob

You can use the controls to configure all functions of your appliance and to obtain information about the operating status.

The markings on the left-hand control knob show the assignment to the cooking zones. The markings on the right-hand control knob show the assignment to the temperature settings, the keep warm function and the cleaning setting.

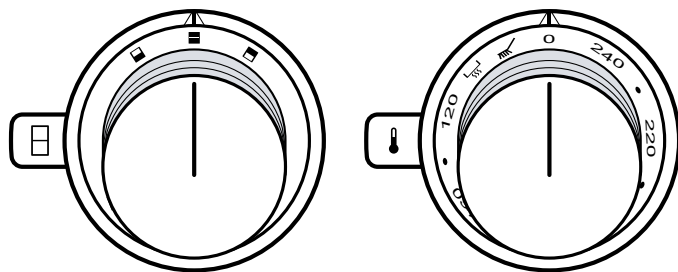

- |  |  |
|--|--|
|  | Both cooking zones are operating         |
|  | Only the front cooking zone is operating |
|  | Only the rear cooking zone is operating  |
|  | Keep warm function                       |
|  | Cleaning setting                         |

### 4.3 Indicator on the illuminated ring

Each control knob is encircled by an illuminated ring with various display functions.

Indicator	Name
Off	Appliance OFF
Lights up: Orange	Appliance ON
Flashing: Orange	Appliance OFF Residual heat indicator
Flashing alternately: Orange and white	Safety switch-off function, power failure
Flashing alternately: Yellow and magenta	Appliance fault. Call customer service.
Lights up: Green for a few seconds, then turns yellow	The appliance is initialising during initial connection or following a power failure

### 4.4 Function

Teppan Yaki means frying and cooking food according to an old, Japanese tradition. You can cook the food directly on the frying surface without using pots and pans. Use the spatula supplied to turn the food or remove food residues if necessary.

### 4.5 Residual heat indicator

After switching off the appliance, the illuminated ring on the control knob slowly flashes until the appliance has cooled enough for it to be safe to touch.

### 4.6 Automatic switch-off

For your safety, the appliance has a safety shut-off function. Any heating process is switched off after 4 hours if the appliance controls are not used during this time. The heating element also remains switched off after a power cut. The illuminated ring on the right-hand control knob flashes white and orange alternately.

## 5 Before using for the first time

Clean the appliance and accessories.

## 5.1 Heating up the appliance

- ▶ To eliminate the new-appliance smell, heat up the empty appliance at 200 °C for a few minutes. Smoke development and odour development are normal. Ventilate the installation room well.

# 6 Basic operation

## 6.1 Switching on the appliance

1. Push in the right-hand control knob ① and turn it clockwise or anti-clockwise to the required temperature between 120–240 °C ②.

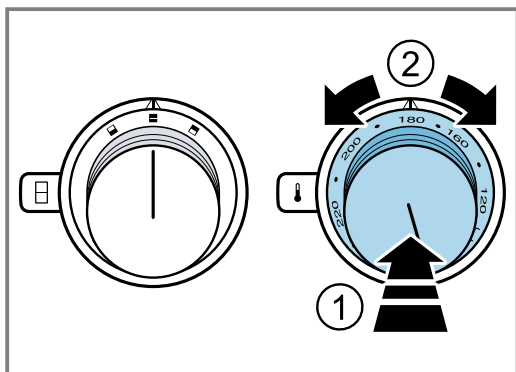

- ✓ The illuminated ring on the control knob flashes while the appliance is heating up.
2. Push in the left-hand control knob and select the required cooking zone to heat up only the front or rear cooking zone or the entire frying surface.
  3. Wait until the set temperature has been reached.
- ✓ The illuminated ring on the control knob lights up continuously.

4. Use the spatula or a heat-resistant brush (e.g. silicone brush) to spread a little oil or fat evenly over the frying surface.
5. Place the food directly onto the frying surface.
  - Do not use pots or pans.
6. Use the spatula supplied to turn the food.

## 6.2 Switching off the appliance

### ⚠ WARNING – Risk of burns!

The appliance remains hot for a long time after it is switched off.

- ▶ Do not touch the appliance while the residual heat indicator is lit.
- ▶ Turn the control knob to 0.

## 6.3 Switching on the keep warm function

You can keep food warm on the keep warm function.

1. Turn the right-hand control knob to .
2. Use the left-hand control knob to select the entire frying surface, only the front or the rear cooking zone.

# 7 How it works

You can find the right settings for different food here as well as helpful comments. We have perfectly tailored these recommendations to your appliance.

## 7.1 Tips for boiling and frying

- Do not place the food on the appliance until the heating display has gone out. When increasing the temperature between two preparations, do not place the food until the heating display has gone out.
- Use the spatula to press the meat, poultry and fish pieces flat on the frying surface. In order not to destroy fibres, do not turn the food until it is easily detached from the plate. Otherwise, liquid may leak out, causing the food to dry out.
- When roasting, ensure that the pieces of meat, poultry and fish do not touch each other. Otherwise, the food may draw out liquid.
- Do not pierce or cut the meat while cooking it, otherwise meat juice may escape.
- To prevent water and soluble nutrients from escaping, do not add salt to meat, poultry or fish until it has been fried.

- Before frying, you can roll fish fillets in flour so that the fish fillet sticks less firmly.
- Fry fish fillets on the skin side first. If possible, only turn the fish fillet once.
- Only use oils and fats that can be heated to a high temperature and are suitable for frying, e.g. refined plant oils or clarified butter.
- The frying surface is hotter in the centre than in the edge area. If you are cooking food with different cooking times and temperature requirements at the same time, you can arrange the food optimally on the plate. Also take note of the different temperatures for the frying surface when selecting the quantity of food. The thinner the food, the higher the temperature and the shorter the cooking time.
- When working with only one heating zone, select the highest setting in each case for the temperature range specified in the cooking table. Alternatively, you can set 10 °C more than you are used to from preparing using both heating zones. Use approx. half of the specified quantity.

## 7.2 Recommended settings

The setting values are only intended as a guideline because more or less heat will be required depending on the type and condition of the food.

### Meat and poultry

Food	Temperature in °C	Cooking time in mins	Comments
Beef steak, medium, 2.5-3 cm	1. Sear at 230-240 °C 2. Continue cooking at 180 °C	1. Fry for 2 mins each side 2. Continue frying for 6-11 mins	E.g. entrecôte, fillet steak, rump steak. The steak is medium when meat juice can be seen on the surface.
Pork neck steak, 2 cm	210-220	15-18	
Veal escalope, 1.5 cm	190-200	16-20	
Strips of beef or pork, 800-900 g	230-240	6-8	Distribute the pieces of meat evenly; they should not be touching.
Strips of poultry, 800-900 g	180-190	10-12	Distribute the pieces of meat evenly; they should not be touching.
Minced meat, 600 g	230-240	7-8	
Saddle of lamb, medium, 1.5–2.5cm	1. Sear at 200 °C 2. Continue cooking at 160 °C	1. Fry for 2 mins each side 2. Continue frying for 4-6 mins	
Turkey steak, 1.5 cm	200-210	12-16	
Poultry liver, 1 cm	200-210	3-5	

### Fish and seafood

Food	Temperature in °C	Cooking time in mins	Comments
Fish fillet, 1 cm	210-220	5-7	E.g. perch, cod, basa, haddock,
Fish fillet, 2 cm	190-200	7-10	plaice, monkfish, sole, pikeperch
Fish fillet, 2.5 cm	180-190	15-17	
Salmon steak, 2.5 cm	180-190	15-17	
Salmon steak, 3 cm	160-170	18-20	
Tuna steak, 2.5-3 cm	180-190	17-20	
Prawns, 30 g each	190-200	6-7	
Scallops, 30 g each	190-200	8-12	

### Vegetables

Food	Temperature in °C	Cooking time in mins	Comments
Aubergines, sliced, 600 g	180-190	6-8	Salt the aubergines and leave to stand for approx. 30 minutes before frying. Then dry.
Mushrooms, sliced, 600 g	230-240	10-12	
Carrots, julienne, 600 g	180-190	12-16	
Potatoes, boiled, sliced, 600 g	200-220	7-10	
Peppers, cut into strips, 600 g	200-210	8-12	
Courgettes, sliced, 600 g	180-190	8-10	
Onions or leeks, cut into rings, 600 g	170-190	5-7	

### Egg-based dishes and desserts

Food	Temperature in °C	Cooking time in mins	Comments
Fried eggs, scrambled eggs, 4-6 eggs	180-190	3-5	

Food	Temperature in °C	Cooking time in mins	Comments
Crêpes, 2-6 pcs	180-190	1-2 mins each side	
Fruit, sliced, 300-400 g	180-190	5-7	E.g. pineapple, apple, mango. Use clarified butter for frying. Sweeten with sugar or honey if desired.
Banana in coconut, 4 halves	180-190	6-9	

### Side dishes and miscellaneous

Food	Temperature in °C	Cooking time in mins	Comments
Rice, boiled, 500 g	190-200	5-7	
Pine nuts, 300 g	160	5-7	Turn frequently
Rice noodles, boiled, 400 g	200-220	4-5	
Tofu, 300 g	200-220	3-5	Turn frequently
White bread cubes or croutons, 100 g	170	10-12	Turn frequently to begin with

## 7.3 Using the with Teppan Yaki with cookware

You can also use the Teppan Yaki to cook with cookware.

- Cooking methods that require little heat supply are suitable for using the cookware with Teppan Yaki. You can heat food quickly on the hob first, if required, before continuing cooking on the Teppan Yaki.
- For melting, defrosting and keeping warm, approx. 140 °C sufficient.  
160–200 °C is sufficient for soaking rice and cereals, and for heating small quantities of food.

- Use heat-resistant cookware with a lid. To prevent damage to the stainless steel frame, carefully place the cookware on the heating surface.
- Note that using the Teppan Yaki with cookware is not energy-saving if the cookware is smaller than the heated surface.
- If you do not require the entire frying surface, you can use the left-hand control knob to select only the front or rear area. You can find the ideal temperature for your application by moving the cookware.

# 8 Cleaning and servicing

To keep your appliance working efficiently for a long time, it is important to clean and maintain it carefully.

## 8.1 Cleaning products

You can obtain suitable cleaning products from after-sales service or the online shop.

### **WARNING – Risk of electric shock!**

An ingress of moisture can cause an electric shock.

- ▶ Do not use steam- or high-pressure cleaners to clean the appliance.

### **WARNING – Risk of burns!**

The appliance becomes hot during operation.

- ▶ Allow the appliance to cool down before cleaning.

### **ATTENTION!**

Unsuitable cleaning products may damage the surfaces of the appliance.

- ▶ Do not use harsh or abrasive detergents.
- ▶ Do not use cleaning products with a high alcohol content.
- ▶ Do not use hard scouring pads or cleaning sponges.
- ▶ Only use glass cleaners, glass scrapers or stainless steel care products if recommended in the cleaning instructions for the relevant part.

- ▶ Wash sponge cloths thoroughly before use.

## 8.2 Cleaning the cooled frying surface

1. Use the spatula to remove the worst of the residue.
2. Pour a little water (maximum 250 ml) and add a drop of washing-up liquid on the frying surface so that it is just covered.
3. Turn the right-hand control knob to .
4. Leave the dirt to soak for approx. 5 to 10 minutes.
5. Use a washing-up brush to clean the frying surface.
6. Mop up and remove the liquid with a soft sponge.
7. Clean stubborn or greasy dirt with the powder detergent or the cleaning gel.
  - → "Clean greasy dirt on the frying surface with the "Wiener Kalk" cleaning powder", Page 8
  - → "Cleaning burnt-on dirt on the frying surface using the cleaning gel", Page 7
8. Carefully remove any detergent residue.
9. Dry the frying surface with a soft cloth.

### **Cleaning burnt-on dirt on the frying surface using the cleaning gel**

1. Allow the appliance to cool down.
2. Follow the instructions on the packaging for the cleaning gel.

3. Apply the cleaning gel to the dirt and leave it to work for at least 2 hours.
  - Leave heavy soiling overnight.
4. Rinse the cleaning gel thoroughly from the frying surface.

### Clean greasy dirt on the frying surface with the "Wiener Kalk" cleaning powder

1. Follow the instructions on the packaging for the powder detergent.
2. Make a paste from the cleaning powder and water.
3. Wipe with the paste in the brush direction of the surface and clean the frying surface.

### 8.3 Cleaning the frying surface between two roasting processes

Ice cubes are better suited than water for cleaning the appliance when hot as they cause less splashing and steam.

#### **WARNING – Risk of burns!**

Splashing and steam occur when water or ice cubes are poured onto the hot frying surface.

- ▶ Do not lean over the appliance.
  - ▶ Maintain a safe distance.
1. Switch off the appliance.
  2. Use the spatula to push approx. 4 or 5 ice cubes over the hot frying surface.
  3. Use the spatula to remove dirt that has begun to soften.
  4. Switch on the appliance.

5. Wait until the set temperature has been reached.
  - ✓ The illuminated ring on the control knob lights up continuously.
6. Place the food on the frying surface.

### 8.4 Cleaning the stainless steel frame

1. Clean the stainless steel frame using hot soapy water and a dish cloth.
  - Use only a small amount of water for cleaning.
  - Do not allow water to get into the appliance.
2. Soak burnt-on remains with a small amount of soapy water. Do not scour burnt-on remains.
3. Remove heavy soiling or yellow discolouration caused by heat using the stainless steel cleaner.
4. Dry with a soft cloth.

### 8.5 Cleaning the control knob

#### Notes

- Do not use a glass scraper.
  - You cannot remove the knob for cleaning.
  - Lemon and vinegar are not suitable for cleaning and may create dull patches.
1. Clean the control knob with warm soapy water and a soft cloth.
  2. Do not use too much water when cleaning.

### 8.6 Cleaning the spatula

1. Clean the spatula using soapy water and a dish cloth.
2. Clean the spatula in the dishwasher as necessary.

## 9 Troubleshooting

You can rectify minor faults on your appliance yourself. Read the troubleshooting information before contacting after-sales service. This will avoid unnecessary costs.

#### **WARNING – Risk of injury!**

Improper repairs are dangerous.

- ▶ Repairs to the appliance should only be carried out by trained specialist staff.
- ▶ If the appliance is defective, call Customer Service. → "Customer Service", Page 9

#### **WARNING – Risk of electric shock!**

Improper repairs are dangerous.

- ▶ Repairs to the appliance should only be carried out by trained specialist staff.
- ▶ Only use genuine spare parts when repairing the appliance.
- ▶ If the power cord or the appliance power cable of this appliance is damaged, it must be replaced with a special power cord or special appliance power cable, which is available from the manufacturer or its Customer Service.

### 9.1 Malfunctions

Fault	Cause and troubleshooting
The appliance is not working.	The mains plug of the power cord is not plugged in. <ul style="list-style-type: none"> <li>▶ Connect the appliance to the power supply.</li> </ul>
	The circuit breaker in the fuse box has tripped. <ul style="list-style-type: none"> <li>▶ Check the circuit breaker in the fuse box.</li> </ul>
	There has been a power cut. <ul style="list-style-type: none"> <li>▶ Check whether the lighting in your kitchen or other appliances are working.</li> </ul>





Fault	Cause and troubleshooting
The appliance does not work. The illuminated ring on the control knob is flashing orange and white alternately.	There has been a power cut. ▶ Check whether the lighting in your kitchen or other appliances are working.
The appliance does not heat up when it is switched on. All of the illuminated rings around the control knobs light up white for 10 seconds after switch-on. The illuminated ring around the active control knob then lights up orange.	Demo mode is activated. ▶ Deactivate the demo mode. → <i>Page 9</i>
The appliance does not heat up when it is switched on. The illuminated ring on the control knob is flashing yellow and magenta alternately.	Electronics fault ▶ Call the after-sales service. → <i>"Customer Service", Page 9</i>
The appliance switches off while operating. The illuminated ring on the control knob is flashing orange and white alternately.	The automatic switch-off → <i>Page 4</i> has switched off the heating process. <b>1.</b> Turn the right-hand control knob to 0. <b>2.</b> Switch the appliance back on.  Power failure in the household: Following a power failure, the appliance remains switched off for safety reasons. <b>1.</b> Turn the right-hand control knob to 0. <b>2.</b> Switch the appliance back on.

## 9.2 Deactivating demo mode

The appliance does not heat up in demo mode. If all of the illuminated rings on the control knobs light up white for 10 seconds after switch-on, demo mode is activated. If you turn the right-hand control knob to another position, the illuminated ring lights up orange on the control knob.

- 1.** Turn the right-hand control knob to 0.
- 2.** Disconnect the appliance from the mains power supply.
- 3.** Wait at least 30 seconds.
- 4.** Re-connect the appliance.
- ✓ The illuminated rings on the control knobs light up green for a few seconds and then turn yellow.
- 5.** Wait until the illuminated rings no longer light up.

- 6.** Within the next 3 minutes, turn the right-hand control knob to 240 °C, clockwise to  and anti-clockwise to 0.
- 7.** Wait until the illuminated ring on the control knob lights up yellow.
- 8.** Turn the control knob clockwise to .
- ✓ The illuminated ring on the control knob lights up green.
- 9.** Wait for 5 seconds.
- ✓ The illuminated ring on the control knob lights up yellow.
- ✓ Demo mode is deactivated.
- 10.** To save the setting and exit the menu, turn the control knob to 0, anti-clockwise to 240 °C, clockwise to  and anti-clockwise to 0.
- 11.** Wait until the illuminated ring on the control knob no longer lights up.

# 10 Customer Service

Function-relevant genuine spare parts according to the corresponding Ecodesign Order can be obtained from Customer Service for a period of at least 10 years from the date on which your appliance was placed on the market within the European Economic Area.

**Note:** Under the terms of the manufacturer's warranty the use of Customer Service is free of charge.

Detailed information on the warranty period and terms of warranty in your country is available from our after-sales service, your retailer or on our website.

If you contact Customer Service, you will require the product number (E-Nr.) and the production number (FD) of your appliance.

The contact details for Customer Service can be found in the enclosed Customer Service directory or on our website.

## 10.1 Product number (E-Nr.) and production number (FD)

You can find the product number (E-Nr.) and the production number (FD) on the appliance's rating plate.

The rating plate is located on the underside of the appliance. Make a note of your appliance's details and the Customer Service telephone number to find them again quickly.

# 11 Disposal

## 11.1 Disposing of old appliance

Valuable raw materials can be reused by recycling.

1. Unplug the appliance from the mains.
  2. Cut through the power cord.
  3. Dispose of the appliance in an environmentally friendly manner.
- Information about current disposal methods are available from your specialist dealer or local authority.



This appliance is labelled in accordance with European Directive 2012/19/EU concerning used electrical and electronic appliances (waste electrical and electronic equipment - WEEE). The guideline determines the framework for the return and recycling of used appliances as applicable throughout the EU.

# 12 Installation instructions



## 12.1 Scope of delivery

After unpacking all parts, check for any damage in transit and completeness of the delivery.

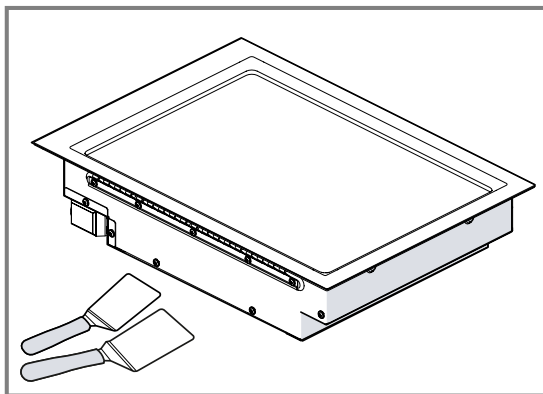

Order the appropriate control knob in black or stainless steel.

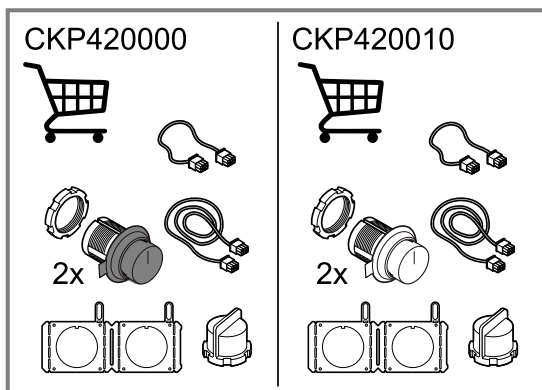

## 12.2 Appliance dimensions

You will find the dimensions of the appliance here

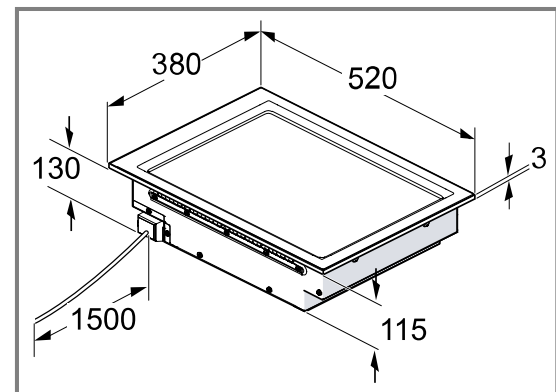

## ⚠ 12.3 General information

- Read this instruction manual carefully.
- Only a licensed expert may connect the appliance.
- Switch off the power supply before carrying out any work.
- Never use this appliance in boats or in vehicles.
- Follow the worktop manufacturer's recommendations.

## 12.4 Instructions for the electrical connection

In order to safely connect the appliance electrically, observe this information.

- Check the household wiring before connecting the appliance. Ensure that there is sufficient fuse protection for the household wiring. The voltage and frequency of the appliance must match the electrical installation (see rating plate).

- Ensure that the power supply is properly earthed, that the fuse protection is sufficient and the cable and wiring system in the building is sufficiently dimensioned for the electrical power of the appliance.
- Route the connection cable in such a way that it does not touch the hot casing.
- Use only the connection cable that is supplied with the appliance or is provided by technical customer service.
- This appliance complies with the EC interference suppression regulations.
- The appliance corresponds to protection class 1. You should therefore only use the appliance with a protective earth connection.
- Ensure that the protection against contact is guaranteed during installation.
- Only a qualified electrician may connect appliances without a plug. They are subject to the requirements of the local electricity provider. We recommend installing a residual-current-operated circuit-breaker (RCCB) in the appliance's power supply circuit.
- Carry out the electrical connection in accordance with the installation instructions. The appliance may be damaged if it is not connected correctly.
- The manufacturer shall assume no liability for malfunctions or damage resulting from incorrect electrical wiring.
- We recommend installing a socket equipped with protective-earth contacts behind the appliance, approximately 70 cm above the floor, in accordance with regulations. Only a qualified electrician may install a protective contact socket in accordance with the relevant regulations.

## 12.5 Safe installation

Follow these safety instructions when installing the appliance.

### **WARNING – Risk of electric shock!**

Improper repairs are dangerous.

- ▶ Repairs to the appliance should only be carried out by trained specialist staff.
- ▶ Only use genuine spare parts when repairing the appliance.
- ▶ If the power cord or the appliance power cable of this appliance is damaged, it must be replaced with a special power cord or special appliance power cable, which is available from the manufacturer or its Customer Service.

It must always be possible to disconnect the appliance from the electricity supply. The appliance must only be connected to a protective contact socket that has been correctly installed.

- ▶ The mains plug of the mains power cable must be easily accessible after installation of the appliance.
- ▶ If this is not possible, an all-pole isolating switch must be integrated into the permanent electrical installation according to the conditions of overvoltage category III and according to the installation regulations.
- ▶ The permanent electrical installation must only be wired by a professional electrician. We recommend installing a residual-current circuit breaker (RCCB) in the appliance's power supply circuit.

### **WARNING – Risk of injury!**

Components inside the appliance may have sharp edges.

- ▶ Wear protective gloves.

### **WARNING – Risk of electric shock!**

Incorrect installation is dangerous.

- ▶ Connect and operate the appliance only in accordance with the specifications on the rating plate.
- ▶ Connect the appliance to a power supply with alternating current only via a properly installed socket with earthing.
- ▶ The protective conductor system of the domestic electrical installation must be properly installed.
- ▶ Never equip the appliance with an external switching device, e.g. a timer or remote control.
- ▶ When the appliance is installed, the mains plug of the power cord must be freely accessible. If free access is not possible, an isolating switch must be integrated into the permanent electrical installation according to the installation regulations.
- ▶ When installing the appliance, check that the power cable is not trapped or damaged.

## 12.6 Information about the installation room

For safe operation, observe the following information regarding the installation area.

- Install the appliance in accordance with the installation diagram.
- Observe the minimum clearance from the side walls, parts of the cupboard, and to the rear.

## 12.7 Information about flush installation

With the flush installation, the appliance and worktop are on one level. There is no unattractive stepping between the appliance and the worktop.

You can install the appliance in the following temperature-resistant and waterproof worktops:

- Stone worktops
- Plastic worktops, e.g. Corian®
- Solid wood worktops

Coordinate with the worktop manufacturer when using other materials.

Installation in compressed-wood worktops is not possible.

Have all cut-out work on the worktops carried out in a specialist workshop in compliance with the installation diagram. The cut-out must be neat and precise since the cut edge is visible on the surface.

Clean and degrease the cut-out edges with a suitable cleaning agent. When doing so, observe the usage instructions from the silicone manufacturer.

## 12.8 Installation accessories

Here, you can find an overview of the installation accessories.

Use the accessories only as specified. The manufacturer shall accept no liability if you use the accessories incorrectly.

Accessories	Order number
Connection strip for surface-mounted installation	VA420010

Accessories	Order number
Connection strip for flush installation	VA420004
Appliance cover, stainless steel	VA440010

## 12.9 Combining multiple appliances

**Requirement:** You need a suitable connection strip to combine several Vario appliances. You can obtain the connection strip as an optional accessory.

- When making the unit cut-out, allow extra space for the connecting strip between the appliances.
  - Observe the installation instructions for the connection strip.

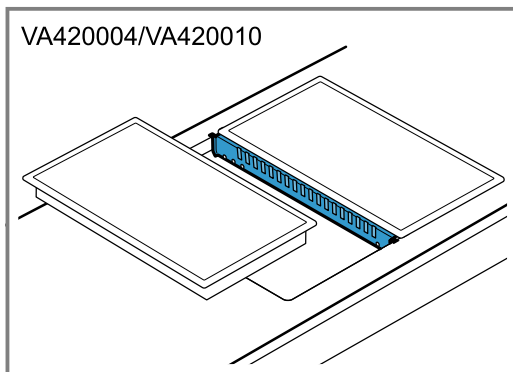

- If required, install the appliances in individual cut-outs.
  - Maintain a bar width of at least 50 mm between the individual cut-outs.

## 12.10 Installing the appliance flush with the frameless induction hobs

- For flush installation in combination with frameless induction hobs, cut out the support edge with 6.5 mm.

- Make the unit cut-out in the worktop for one or more Vario appliances in accordance with the installation drawing.
  - Observe the installation instructions for the connection strip VA420004.

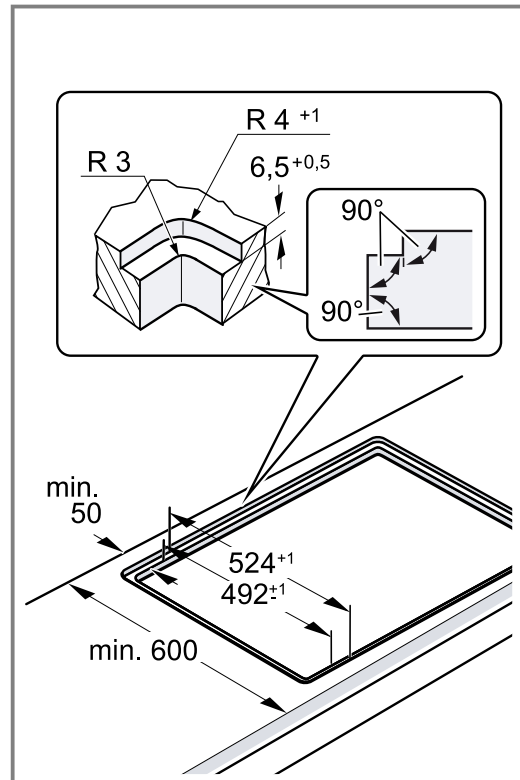

## 12.11 Installing the appliance cover

You can obtain a suitable appliance cover as an optional accessory.

- Secure the appliance cover to the appliance before installing it.
  - Follow the installation instructions for the appliance cover.

- When making the cut-out, take the additional space required for the appliance cover into consideration.

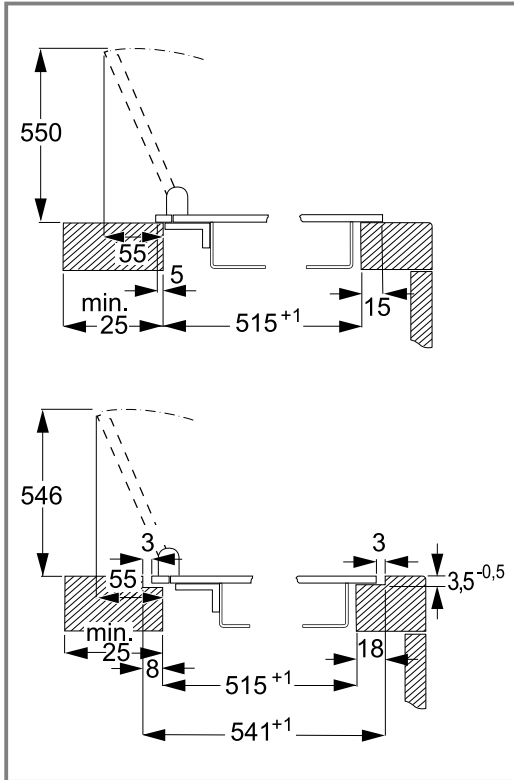

- Ensure that the thickness of the worktop corresponds to the required minimum thickness.

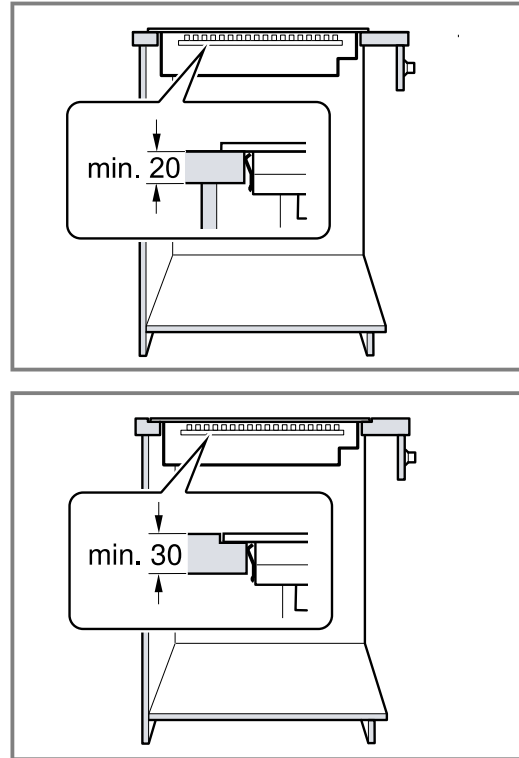

## 12.12 Preparing the unit

### Requirements

- The fitted units are heat-resistant up to 90 °C.
  - The worktop is level, horizontal and stable.
- Follow the instructions on combining several appliances.  
→ "Combining multiple appliances", Page 12
  - Ensure that the stability of the fitted unit is guaranteed after the cut-outs have been made.

4. Make the unit cut-out in the worktop for one or more Vario appliances in accordance with the installation drawing.

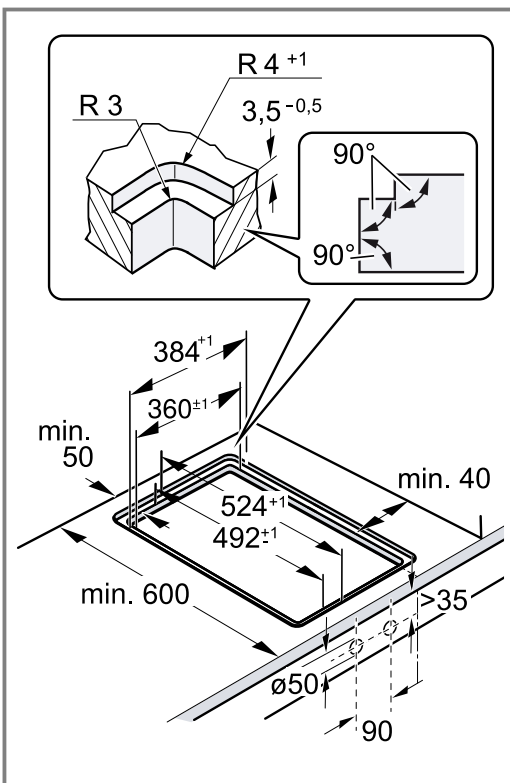
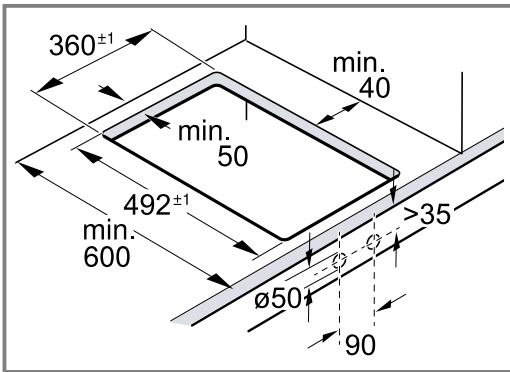

5. Ensure that the angle of the cut surface to the worktop is 90°.

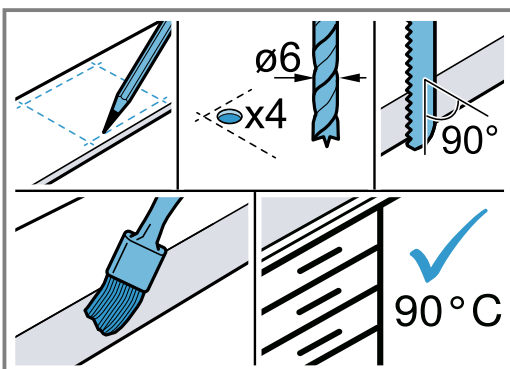

6. The cut-out edges at the sides must be flat to ensure that the retaining springs sit correctly on the appliance.  
7. For multi-layer worktops, affix appropriate strips to the side in the unit cut-out, if required.

8. Remove dust and residues from the cut-out work. Seal the cut surfaces so that they are heat-resistant and waterproof.  
9. Ensure that the minimum clearance from the bottom of the appliance to furniture parts is 10 mm.  
10. Use suitable substructures to ensure the load-bearing capacity and stability of the unit, particularly in the case of thin worktops.  
– Take the appliance weight, including additional load, into consideration.  
– Use heat-resistant and moisture-resistant reinforcement material.

**Note:** Only check that the appliance is level once it has been installed in the installation opening.

### Making the cut-out for the control knob

1. Create the holes for the control knob in accordance with the enclosed instructions.
2. If the panel is more than 23 mm thick, cut out the rear of the front panel for the retaining plate.
3. Note the clearances between the control knobs.

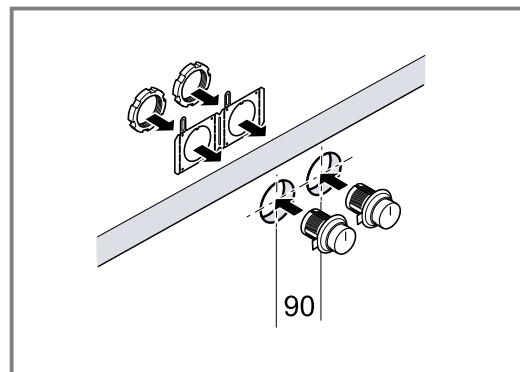

4. After making the cut-outs, remove any shavings.
5. Seal the cut surfaces so that they are heat-resistant and waterproof.

### 12.13 Installing the control knob

1. If required, and depending on the distance between the control knobs, break off the retaining plate at the perforation.

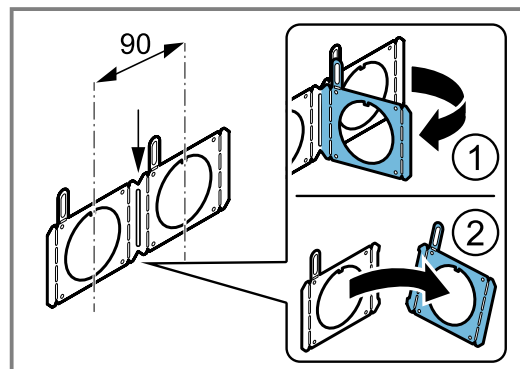

2. Hold the retaining plate in place against the rear of the control panel.

3. When fitting an individual control knob, use 2 screws to hold the retaining plate in place and prevent it from rotating.
  - In the case of stone worktops, stick the retaining plate using heat-resistant, two-component adhesive.

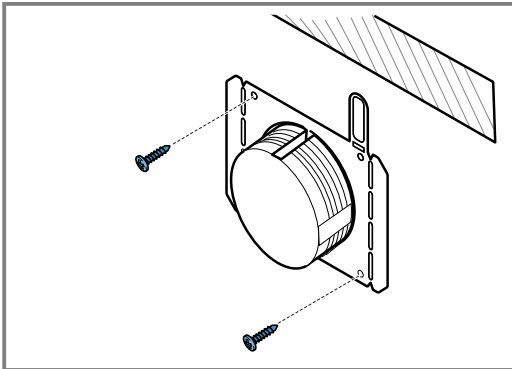

4. Remove the protective film from the rear of the illuminated ring.

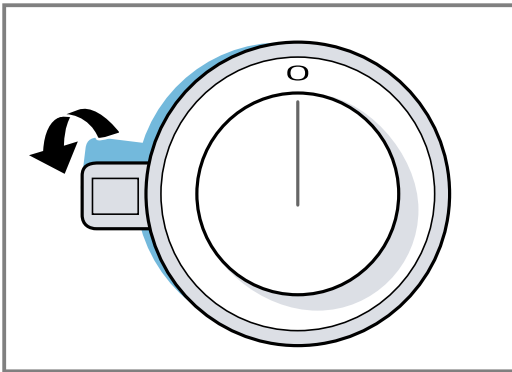

5. Install the control knob in the correct sequence.

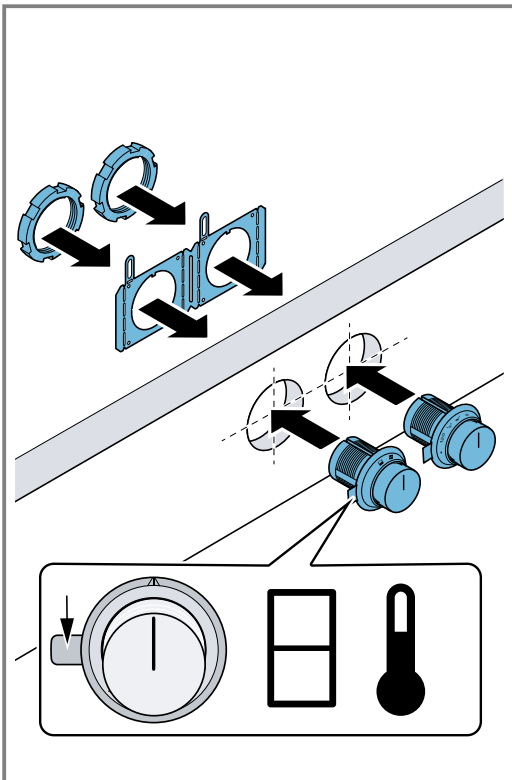

6. Push the control knob into the hole.
  - Always position the side marking on the control knob on the left.

7. Ensure that the retaining lug on the retaining plate is located on the upper side and the control knob is in the zero setting.

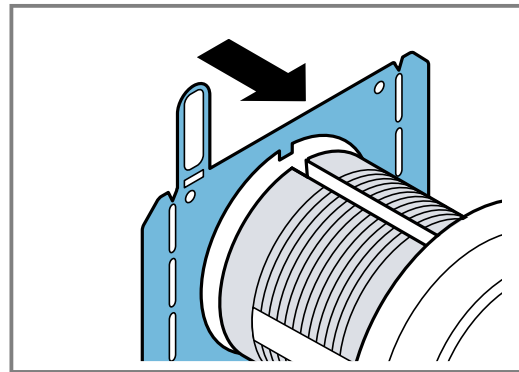

8. On the rear of the control knob, tighten the retaining nut using the installation tool provided.

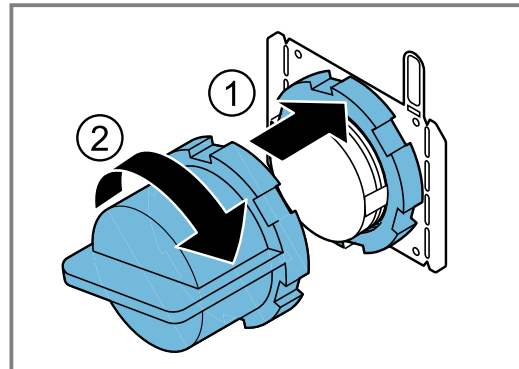

9. Align the control knob precisely in the zero setting.

### 12.14 Connecting the control knob to the connection cables

1. Connect all of the control knobs to the enclosed shorter connection cables.

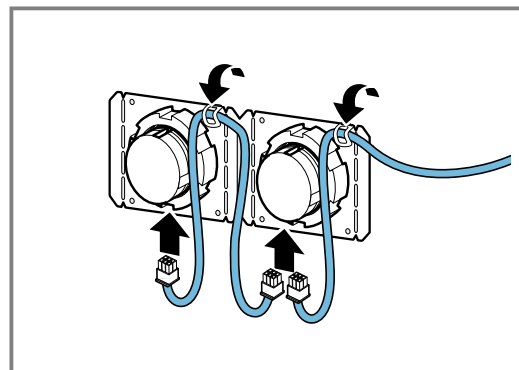

- The two connectors on the control knob are identical.
2. Ensure that the plugs snap into place in the connectors.
  3. Attach the longer connection cable to one of the control knobs to connect it to the appliance. You can connect the appliance to any control knob.
  4. Ensure that the plug engages in the socket.
  5. After installation, check that all of the plug connections are seated correctly.
  6. To fix all connection cable in place after installation, bend the lugs on the retaining plates.

## 12.15 Connecting connection cables to the appliance

1. Connect the connection cable for any of the control knobs to the appliance's socket.

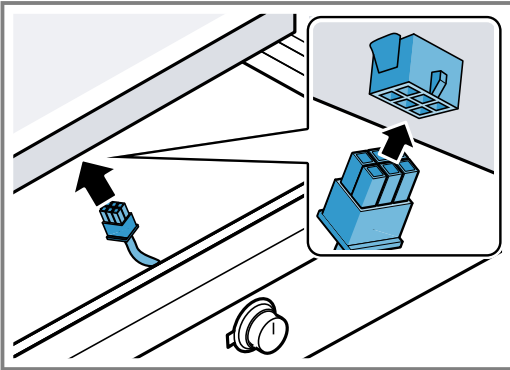

2. Ensure that the plug engages in the socket.

## 12.16 Installing the appliance

### **⚠ WARNING – Risk of electric shock!**

If the insulation of the power cord is damaged, this is dangerous.

- ▶ Never let the power cord come into contact with hot appliance parts or heat sources.
- ▶ Never let the power cord come into contact with sharp points or edges.
- ▶ Never kink, crush or modify the power cord.

1. Keeping the appliance level, insert it into the unit cut-out.

2. Push the appliance firmly into the unit cut-out from above.
  - Ensure that the appliance is firmly positioned in the unit cut-out and does not move.
  - If the width of the cut-out is at the upper tolerance limit, secure a bar at the sides of the cut-out in each case, if necessary.

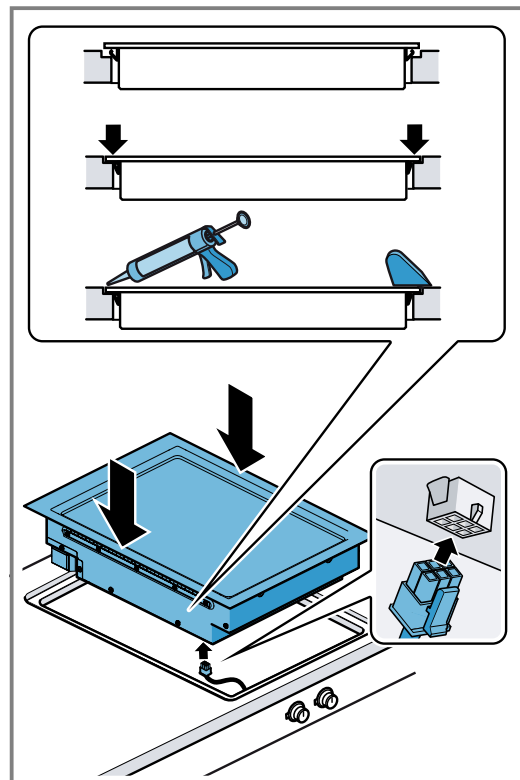
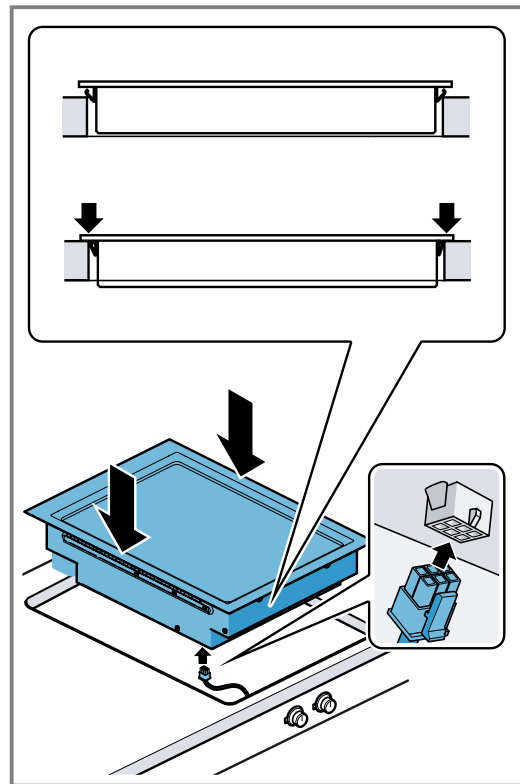

3. Connect the appliance to the power supply.
4. Check the functionality of the appliance.



## 12.17 Sealing the joints

For flush installation, seal the joints with silicone.

**Requirement:** You must carry out a function test before sealing any joints.

1. Seal all around the gap using suitable, heat-resistant silicone, e.g. Novasil® S70 or Ottoseal® S70.

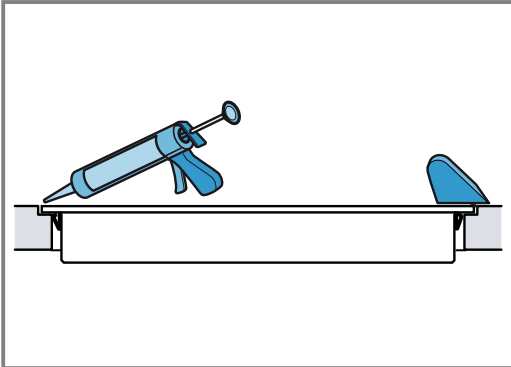

Unsuitable silicone adhesive causes permanent discoloration to natural stone worktops.

2. Use the smoothing agent recommended by the manufacturer to smooth the joint.
3. Observe the usage instructions for the silicone adhesive.
4. Leave the silicone adhesive to dry for at least 24 hours.  
The drying time depends on the ambient temperature.
5. Do not operate the appliance until the silicone has dried completely.

## 12.18 Removing the appliance

### ATTENTION!

Tools may damage the appliance frame.

- ▶ Do not prise out the appliance from above.
1. Disconnect the appliance from the power supply.
  2. If the appliance is flush-mounted with the surrounding surfaces, remove the silicone seal.
  3. Push out the appliance from below.





**BSH Hausgeräte GmbH**  
Carl-Wery-Straße 34  
81739 München, GERMANY  
[www.gaggenau.com](http://www.gaggenau.com)

Valid within Great Britain:  
Imported to Great Britain by  
BSH Home Appliances Ltd.  
Grand Union House  
Old Wolverton Road  
Wolverton, Milton Keynes  
MK12 5PT  
United Kingdom

**GAGGENAU**



9001798024 en (030421)