A large window overlooking a lake at sunset, with a reflection on a table in the foreground.

The models and dimensions
May 2019

GAGGENAU









The definitive guide to the definitive kitchen

The world of Gaggenau is within your hands.

Our products perform exceptionally, are technologically advanced, built without compromise and designed to be appreciated by both the hand and the eye.

This comprehensive handbook will enable the smooth, we would not say effortless, creation of the kitchen for your client. It is all here, clearly and cleanly presented, easy to find and utterly complete. See for yourself.

The difference is Gaggenau.

The ovens 400 series	5	
The ovens 200 series	31	
The oven EB 333	45	
The Vario cooktops	49	
The cooktops	91	
The ventilation appliances	103	
The cooling appliances	143	
The dishwashers	163	
The accessories	177	



The ovens 400 series

Checklist for appliance combinations 400 series	6
Planning notes for ovens and oven combinations 400 series	8
Ovens 400 series	10
Double oven 400 series	13
Combi-steam ovens 400 series	14
Combi-microwave ovens 400 series	20
Fully automatic coffee machine 400 series	22
Warming drawers 400 series	25
Vacuuming drawer 400 series	28
Accessories special accessories 400 series	29

Checklist for appliance combinations 400 series

This checklist provides the most relevant parameters for the perfect combination and ordering of ovens, Combi-steam ovens, Combi-microwave ovens, fully automatic espresso machine, vacuuming drawers, warming drawers and dishwashers.

In general:

- All appliances shown can be obtained with stainless-steel-backed full glass doors.
- When several appliances are listed (BS/BM and DV/WS), the first appliance is shown.

Vertical combinations

When planning and ordering please note that

- The door hinges of the appliances must be on the same side.
- The door hinge (right-/left-hinged) is not reversible.
- The width of the appliances is identical.
- The control modules of the two appliances should meet each other in the middle of the combination.
- No further appliances may be fitted above the BS.
- Only appliances with controls at the top can be installed above a dishwasher. The niche for appliances that are installed above it must be 56 cm wide. The dishwasher is 60 cm wide.

Horizontal combinations

When planning and ordering please note that

- The door hinges need to be placed on the outside in order to use the full available door opening angle.
- The door hinge (right-/left-hinged) is not reversible.
- A minimum clearance of 10 mm between the two doors must be observed.
- Combi-steam ovens, Combi-microwave ovens and fully automatic espresso machine in combination with a vacuuming drawer or a warming drawer (14 cm in height) have the same total height as a 60 cm wide oven.
- The control modules are either all at the top or all at the bottom.

- BO Ovens
- BS Combi-steam ovens
- BM Combi-microwave ovens
- CM Fully automatic espresso machine
- DV Vacuuming drawers
- WS Warming drawers
- DF Dishwashers

Vertical combination, 76 cm wide appliances



- BS 484/BM 484
- BO 480
- WS 482

- BX 480
- WS 482

Combination of 4, 76 cm wide appliances



- BS 485/BM 485
- BO 481

- BS 484/BM 484
- BO 480

Horizontal combination, 76 cm wide appliances



- BO 481

- BO 480

Vertical combination, 60 cm wide appliances



- BS 474/BM 454
- BO 470/BO 450
- WS 462

- BM 454/BS 474
- CM 450/CM 470
- WS 461/DV 461



- BO 470/BO 450
- DF 481/DF 250

- BS 470
- DF 481/DF 250

- CM 450/CM 470
- DF 481/DF 250

Horizontal combination, 60 cm wide appliances



▪ BO 471/BO 451



▪ BO 470/BO 450



▪ BO 471/BO 451



▪ BS 470
▪ DV 461/WS 461



▪ BO 471/BO 451



▪ CM 450/CM 470
▪ WS 461/DV 461



▪ BS 471
▪ WS 461/DV 461



▪ BS 470
▪ DV 461/WS 461



▪ BS 471
▪ WS 461/DV 461



▪ CM 450/CM 470
▪ DV 461/WS 461



▪ BO 471/BO 451



▪ CM 450/CM 470
▪ WS 461/DV 461



▪ BS 470
▪ DV 461/WS 461



▪ BS 471
▪ WS 461/DV 461



▪ CM 450/CM 470
▪ DV 461/WS 461



▪ BS 470
▪ WS 461/DV 461

Combination of 4 with warming drawer, 60 cm wide appliances



▪ BS 475/BM 455
▪ BO 471/BO 451



▪ BM 454/BS 474
▪ CM 450/CM 470
▪ DV 461/WS 461

Planning notes for the installation of ovens and oven combinations 400 series

General notes

Installation behind kitchen furniture doors

Appropriate measures must be taken to prevent these types of doors from closing when the appliance is heating or while it is cooling down (fan operation).

Combination of ovens and Vario cooling 400 series appliances

Please check the planning notes in the information for Vario cooling 400 series appliances in order to prevent the refrigerator door from colliding with the oven.

Installation side by side

When appliances are installed side by side, the clearance between the appliances must be at least 10 mm (corresponds to the standard outside measurement of the furniture cavity of 600 or 762 mm).

The door hinges need to be placed outside in order to use the full available door opening angle.

When installed next to each other

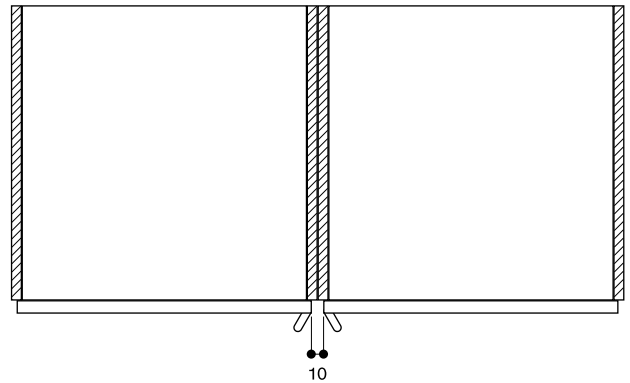

Necessary air cross section at the door edges

Gaggenau ovens 400 series are cooled with fresh air at the top edge and side edges of the door. Hot air is blown out at the door bottom edge. Combi-steam ovens and Combi-microwave ovens have the air inlet at the side edges of the door and the hot air and steam outlets at the top edge of the door. In order to prevent appliances from overheating and to ensure that they cool down as required after operation, appropriate minimum cross sections of free space must be maintained from kitchen furniture edges.

The measurements given in the drawing apply to all appliances. The following must also be observed:

The area above the appliances
BS:

No other electrical appliances should be installed above the BS. It is recommended that a horizontal handle is not fitted on furniture above the BS.

Where the edge of a kitchen unit protrudes more than 20 mm from the front edge of the furniture cavity, the edge of the kitchen furniture panel must be steam resistant as is the case above a dishwasher. Steam may possibly penetrate into the compartment.

The area below the appliances
DV / WS:

It must be ensured that there is sufficient access to the lower edge of the vacuuming drawer and warming drawer, if the thickness of the kitchen furniture door is greater than 20 mm in front of the furniture cavity.

Cross section of the top/bottom door edge gaps

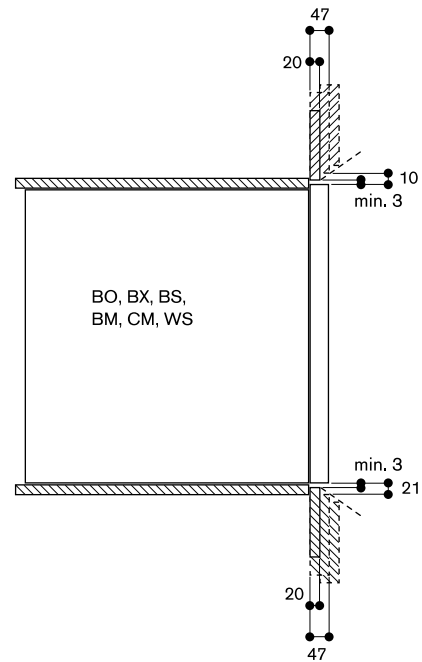

At the sides

In cases where kitchen furniture door thicknesses are greater or where sidewalls protrude up to 34 mm from front of the edge of the furniture cavity, the minimum distance on the hinge side is sufficient for the air supply and a door opening angle of 120°. Above that, a distance of 10 mm or even more is required.

The handle side may, if required, be covered by a side panel provided that the minimum distance is maintained.

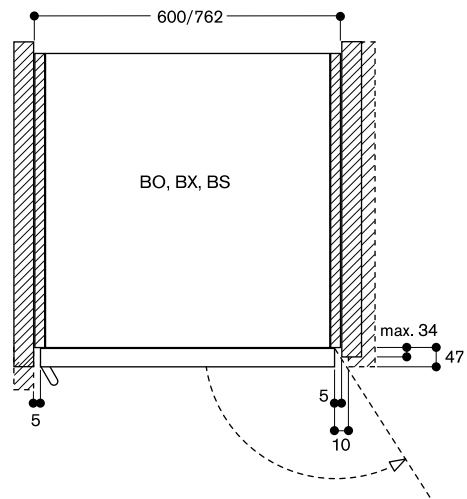
Air inlet cross section at the door edges



Controls at the top

Right-hinged

BO 480 111

Stainless steel-backed full glass door
Width 76 cm

Left-hinged

BO 481 111

Stainless steel-backed full glass door
Width 76 cm

Included in the price

- 1 baking tray, enamelled pyrolysis-safe
- 1 rotisserie spit
- 1 wire rack
- 1 grill tray with wire rack
- 1 plug-in core temperature probe

Special accessories

BA 018 105

Pull-out system
Fully extendable telescopic rails and enamelled cast iron frame.

BA 058 115

Heating element for baking stone and Gastronorm roaster.

BA 058 133

Baking stone.
Incl. baking stone support and pizza paddle (heating element must be ordered separately).
Not in combination with pull-out system.

GN 340 230

Gastronorm roaster in cast aluminium.
GN 2/3, height 165 mm, non-stick.

Oven 400 series

BO 480/BO 481

- Proud mounted installation
- Handleless door / automatic door opening
- Pyrolytic system
- 17 heating methods, with core temperature probe, rotisserie spit and baking stone function
- TFT touch display
- Panel-free appliance with surface control module
- Electronic temperature control from 30 °C to 300 °C
- 110 litres net volume
- Energy efficiency class A

Heating methods

- Hot air.
- Eco hot air.
- Top + bottom heat.
- Top + 1/3 bottom heat.
- Top heat.
- 1/3 top + bottom heat.
- Bottom heat.
- Hot air + bottom heat.
- Hot air + 1/3 bottom heat.
- Full surface grill + circulated air.
- Full surface grill.
- Compact grill.
- Baking stone function.
- Roaster function.
- Dough proving.
- Defrosting.
- Keeping warm.

Handling

- Automatic door opening.
- Rotary knob and TFT touch display operation.
- Clear text display in 25 languages.
- Option to save 50 individual recipes (incl. core temperature probe).
- Information key with use indicators.
- Side-opening door opens up to 180° angle.

Features

- Core temperature probe with automatic shut-off.
- Rotisserie spit.
- Baking stone socket.
- Actual temperature display.
- Rapid heating.
- Timer functions: cooking time, cooking time end, timer, stopwatch, long-term timer.
- 60W halogen light on the top.
- 2 x 10W halogen light on the side.
- Enamelled side shelf supports with 5 tray levels, pyrolysis-safe.

Safety

- Thermally insulated door with quadruple glazing.
- Child lock.
- Safety shut-off.
- Cooled housing with temperature protection.

Cleaning

- Pyrolytic system.
- Gaggenau enamel.
- Heated air cleaning catalyser.

Planning notes

Door hinge not reversible.
The door panel surface of the appliance extends 47 mm from the furniture cavity.
Consider the overhang, when planning to open drawers next to the appliance. When planning a corner solution, pay attention to the 90° door opening angle.
To achieve the 550 mm installation depth, the connection cable needs to follow the slanted edge on the lower right hand corner of the housing. The mains socket needs to be planned outside of the built-in niche.

Please read the installation details regarding air ducting on page 8–9.

Connection

Total connected load 5.5 kW.
Power requirements
220 – 240 V / 50 Hz.
Plan a connection cable.

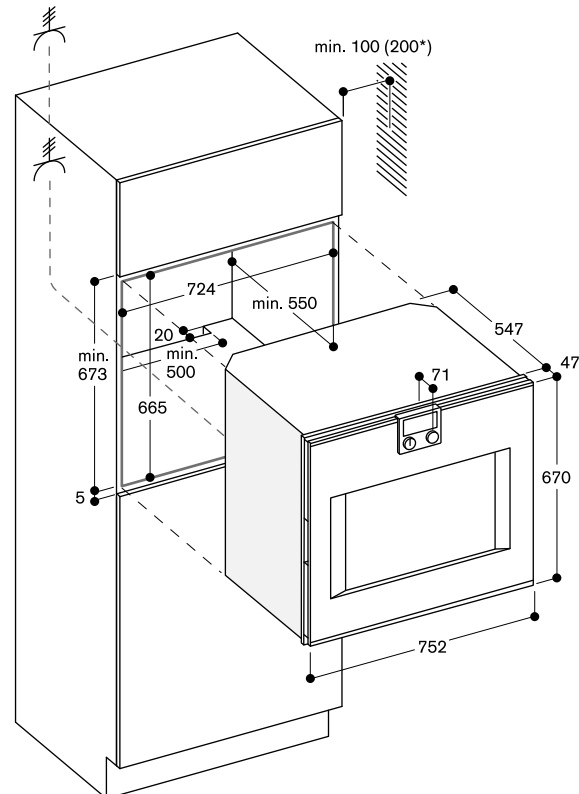
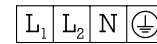

* 200 mm in conjunction with BA 018



Controls at the top

Right-hinged

BO 470 111

Stainless steel-backed full glass door
Width 60 cm

Left-hinged

BO 471 111

Stainless steel-backed full glass door
Width 60 cm

Included in the price

- 2 baking trays, enamelled pyrolysis-safe
- 1 rotisserie spit
- 1 glass tray
- 1 wire rack
- 1 grill tray with wire rack
- 1 plug-in core temperature probe

Special accessories

BA 016 105

Pull-out system

Fully extendable telescopic rails and enamelled cast iron frame.

BA 056 115

Heating element for baking stone and Gastronorm roaster.

BA 056 133

Baking stone.

Incl. baking stone support and pizza paddle (heating element must be ordered separately).

Not in combination with pull-out system.

GN 340 230

Gastronorm roaster in cast aluminium.
GN 2/3, height 165 mm, non-stick.

Oven 400 series

BO 470/BO 471

- Proud mounted installation
- Handleless door / automatic door opening
- Pyrolytic system
- 17 heating methods, with core temperature probe, rotisserie spit and baking stone function
- TFT touch display
- Panel-free appliance with surface control module
- Electronic temperature control from 30 °C to 300 °C
- Net volume 76 litres
- Energy efficiency class A

Heating methods

Hot air.

Eco hot air.

Top + bottom heat.

Top + 1/3 bottom heat.

Top heat.

1/3 top + bottom heat.

Bottom heat.

Hot air + bottom heat.

Hot air + 1/3 bottom heat.

Full surface grill + circulated air.

Full surface grill.

Compact grill.

Baking stone function.

Roaster function.

Dough proving.

Defrosting.

Keeping warm.

Handling

Automatic door opening.

Rotary knob and TFT touch display operation.

Clear text display in 25 languages.

Option to save 50 individual recipes (incl. core temperature probe).

Information key with use indicators.

Side-opening door opens up to 180° angle.

Features

Core temperature probe with automatic shut-off.

Rotisserie spit.

Baking stone socket.

Actual temperature display.

Rapid heating.

Timer functions: cooking time, cooking time end, timer, stopwatch, long-term timer.

60 W halogen light on the top.

2 x 10 W halogen light on the side.

Enamelled side shelf supports with 4 tray levels, pyrolysis-safe.

Safety

Thermally insulated door with quadruple glazing.

Child lock.

Safety shut-off.

Cooled housing with temperature protection.

Cleaning

Pyrolytic system.

Gaggenau enamel.

Heated catalyser to clean the oven air.

Planning notes

Door hinge not reversible.

The door panel surface of the appliance extends 47 mm from the furniture cavity.

Consider the overhang, incl. the door handle where applicable, when planning to open drawers next to the appliance.

When planning a corner solution, pay attention to the 90° door opening angle.

To achieve the 550 mm installation depth, the connection cable needs to follow the slanted edge on the lower right hand corner of the housing.

The mains socket needs to be planned outside of the built-in niche.

Please read the installation details regarding combination with ovens on the page 8–9.

Connection

Total connected load 3.7 kW.

Power requirements

220 – 240 V / 50 Hz.

Plan a connection cable.

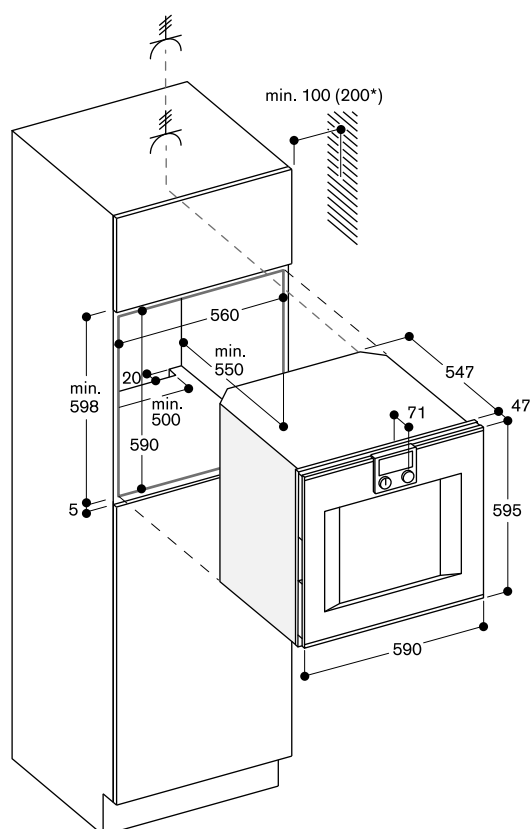
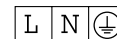

*200 mm in conjunction with BA 016



Controls at the top

Right-hinged

BO 450 111

Stainless steel-backed full glass door
Width 60 cm

Left-hinged

BO 451 111

Stainless steel-backed full glass door
Width 60 cm

Included in the price

- 1 baking tray, enamelled
pyrolysis-safe
- 1 glass tray
- 1 wire rack
- 1 plug-in core temperature probe

Special accessories

BA 016 105

Pull-out system
Fully extendable telescopic rails and
enamelled cast iron frame.

BA 056 115

Heating element for baking stone and
Gastronorm roaster.

BA 056 133

Baking stone.
Incl. baking stone support and pizza
paddle (heating element must be
ordered separately).
Not in combination with pull-out
system.

GN 340 230

Gastronorm roaster in cast aluminium.
GN 2/3, height 165 mm, non-stick.

Oven 400 series

BO 450/BO 451

- Proud mounted installation
- Handleless door / automatic door opening
- Pyrolytic system
- 13 heating methods, with core temperature probe and baking stone function
- TFT touch display
- Panel-free appliance with surface control module
- Electronic temperature control from 30 °C to 300 °C
- 76 litres net volume
- Energy efficiency class A

Heating methods

Hot air.
Eco hot air.
Top + bottom heat.
Top heat.
Bottom heat.
Hot air + bottom heat.
Full surface grill + circulated air.
Full surface grill.
Compact grill.
Baking stone function.
Roaster function.
Dough proving.
Defrosting.

Handling

Automatic door opening.
Rotary knob and TFT touch display operation.
Clear text display in 25 languages.
Option to save 50 individual recipes (incl. core temperature probe).
Information key with use indicators.
Side-opening door opens up to 180° angle.

Features

Core temperature probe with automatic shut-off.
Baking stone socket.
Actual temperature display.
Rapid heating.
Timer functions: cooking time, cooking time end, timer, stopwatch, long-term timer.
60 W halogen light on the top.
10 W halogen light on the side.
Enamelled side shelf supports with 4 tray levels, pyrolysis-safe.

Safety

Thermally insulated door with quadruple glazing.
Child lock.
Safety shut-off.
Cooled housing with temperature protection.

Cleaning

Pyrolytic system.
Gaggenau enamel.
Heated air cleaning catalyser.

Planning notes

Door hinge not reversible.
The door panel surface of the appliance extends 47 mm from the furniture cavity.
Consider the overhang, incl. the door handle where applicable, when planning to open drawers next to the appliance. When planning a corner solution, pay attention to the 90° door opening angle.
To achieve the 550 mm installation depth, the connection cable needs to follow the slanted edge on the lower right hand corner of the housing.
The mains socket needs to be planned outside of the built-in niche.

Please read the installation details regarding air ducting on page 8–9.

Connection

Total connected load 3.7 kW.
Power requirements
220 – 240 V / 50 Hz.
Plan a connection cable.

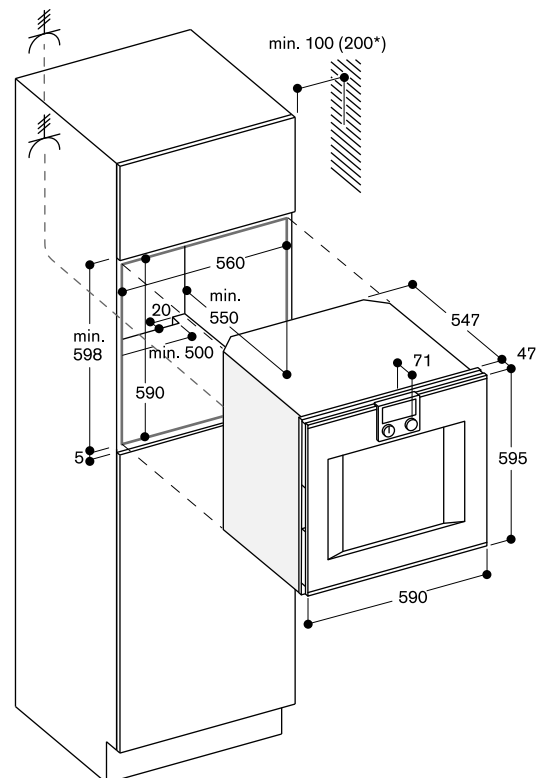
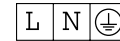

* 200 mm in conjunction with BA 016



Controls centered

Right-hinged

BX 480 111

Stainless steel-backed full glass door
Width 76 cm

Left-hinged

BX 481 111

Stainless steel-backed full glass door
Width 76 cm

Included in the price

- 2 baking trays, enamelled
pyrolysis-safe
- 1 rotisserie spit
- 2 wire racks
- 2 grill trays with wire rack
- 1 plug-in core temperature probe

Special accessories

BA 018 105

Pull-out system
Fully extendable telescopic rails and
enamelled cast iron frame.

BA 058 115

Heating element for baking stone and
Gastronorm roaster.

BA 058 133

Baking stone.
Incl. baking stone support and pizza
paddle (heating element must be
ordered separately).
Not in combination with pull-out
system.

GN 340 230

Gastronorm roaster in cast aluminium.
GN 2/3, height 165 mm, non-stick.

Double oven 400 series

BX 480/BX 481

- Proud mounted installation
- Pyrolytic system
- 17 heating methods, with core
temperature probe, rotisserie spit
and baking stone function
- TFT touch display
- Electronic temperature control from
30 °C to 300 °C
- 2 x 110 litres net volume
- Energy efficiency class A

Heating methods

Hot air.
Eco hot air.
Top + bottom heat.
Top + 1/3 bottom heat.
Top heat.
1/3 top + bottom heat.
Bottom heat.
Hot air + bottom heat.
Hot air + 1/3 bottom heat.
Full surface grill + circulated air.
Full surface grill.
Compact grill.
Baking stone function.
Roaster function.
Dough proving.
Defrosting.
Keeping warm.

Handling

Rotary knob and TFT touch display
operation.
Clear text display in 25 languages.
Information key with use indicators.
Side-opening door opens up to
180° angle.

Features

Core temperature probe with
automatic shut-off (lower oven).
Rotisserie spit (lower oven).
Baking stone socket.
Actual temperature display.
Rapid heating.
Timer functions: cooking time, cooking
time end, timer, stopwatch, long-term
timer.
60 W halogen light on the top.
10 W halogen light on the side.
Enamelled side shelf supports with
5 tray levels, pyrolysis-safe.

Safety

Thermally insulated door with
quadruple glazing.
Child lock.
Safety shut-off.
Cooled housing with temperature
protection.

Cleaning

Pyrolytic system.
Gaggenau enamel.
Heated air cleaning catalyser.

Planning notes

Door hinge not reversible.
The door panel surface of the
appliance extends 47 mm from the
furniture cavity.
The outer edge of the door handle
extends 94 mm from the furniture
cavity.
Consider the overhang, incl. the door
handle, when planning to open
drawers next to the appliance.
When planning a corner solution, pay
attention to the 90° door opening
angle.
To achieve the 550 mm installation
depth, the connection cable needs to
follow the slanted edge on the lower
right hand corner of the housing.
The mains socket needs to be planned
outside of the built-in niche.

Please read the installation details
regarding air ducting on page 8–9.

Connection

Total connected load 9.2 kW.
Power requirements
220 – 240 V / 50 Hz.
Plan a connection cable.

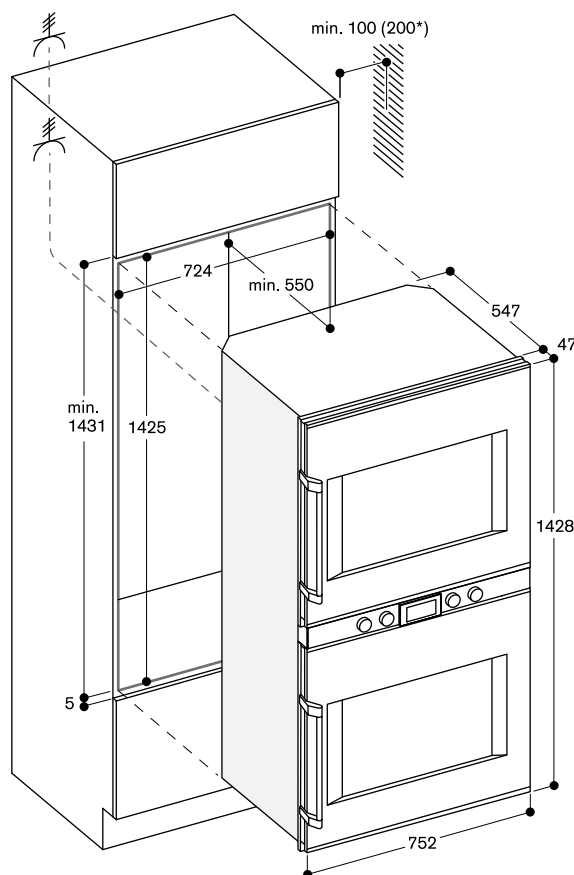
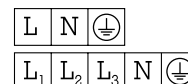

* 200 mm in conjunction with BA 018



Controls at the bottom

Right-hinged

BS 484 111

Stainless steel-backed full glass door
Width 76 cm

Left-hinged

BS 485 111

Stainless steel-backed full glass door
Width 76 cm

Included in the price

- 1 Gastronorm insert, stainless steel, GN 2/3 unperforated
- 1 Gastronorm insert, stainless steel, GN 2/3 perforated
- 1 wire rack
- 1 outlet hose (3 m long)
- 1 water inlet hose (3 m long)
- 1 plug-in core temperature probe
- 4 Cleaning cartridge

Special accessories

CL S10 040

Cleaning cartridges, set of 4
For combi-steam oven with fixed inlet and outlet water connection.

CL S20 040

Descaling cartridges, set of 4
For combi-steam oven with fixed inlet and outlet water connection.

GN 144 230

Gastronorm insert, non-stick, GN 2/3
Unperforated, 40 mm deep, 3l.

GN 154 230

Gastronorm insert, non-stick, GN 2/3
Perforated, 40 mm deep, 3l.

GN 340 230

Gastronorm roaster in cast aluminium.
GN 2/3, height 165 mm, non-stick.

GN 410 230

Gastronorm lid, stainless steel,
GN 2/3.

Combi-steam oven 400 series

BS 484/BS 485

- Proud mounted installation
- Handleless door / automatic door opening
- Fixed inlet and outlet water connection
- Cleaning system, fully automatic
- Hot air 30 °C to 230 °C can be combined with chosen humidity level of 0%, 30%, 60%, 80% or 100%
- Sous-vide cooking with accurate temperature regulation
- Full surface grill behind glass ceramic, combinable with circulated air up to 230 °C and steam
- TFT touch display
- Panel-free appliance with surface control module
- Steaming without pressure
- Electronic temperature control from 30 °C to 230 °C
- Core temperature probe, removable
- Net volume 44 litres
- Energy efficiency class A

Heating methods

Hot air + 100 % humidity.
Hot air + 80 % humidity.
Hot air + 60 % humidity.
Hot air + 30 % humidity.
Hot air + 0 % humidity.
Low temperature cooking.
Sous-vide cooking.
Full surface grill level 1 + humidity.
Full surface grill level 2 + humidity.
Full surface grill + circulated air.
Full surface grill.
Defrosting.
Regenerating.

Handling

Automatic door opening.
Rotary knob and TFT touch display operation.
Clear text display in 25 languages.
Option to save 50 individual recipes (incl. core temperature probe).
Information key with use indicators.
Side-opening door opens up to 180° angle.

Features

Full surface grill 2000 W behind glass ceramic.
Steam removal.
Misting.
Core temperature probe with automatic shut-off.
Actual temperature display.
Timer functions: cooking time, cooking time end, timer, stopwatch, long-term timer.
Electronic boiling point detection.
48 W halogen light on the side.
Hygienic stainless steel cooking interior.
4 tray levels.

Safety

Child lock.
Safety shut-off.
Cooled housing with temperature protection.

Cleaning

Cleaning program, fully automatic.
Descaling program, fully automatic.
Drying program.
Strainer filter, removable.
Demo cleaning program.

Planning notes

Door hinge not reversible.
No other electrical appliances should be installed above the BS.
At no point may the outlet hose be positioned higher than the bottom edge of the appliance. The outlet hose must also be at least 100 mm lower than the appliance outlet (see drawing "drainage connection").
Inlet hose can be extended once. The outlet hose must not be longer than a maximum of 5 m.
The water connection (1) for the inlet hose must always be accessible and not located directly behind the appliance.
The connection of the outlet hose to the siphon (2) must not be directly behind the appliance and should be accessible.
The door panel surface of the appliance extends 47 mm from the furniture cavity.
Consider the overhang, incl. the door handle where applicable, when planning to open drawers next to the appliance.
When planning a corner solution, pay attention to the 90° door opening angle.
To achieve the 550 mm installation depth, the water hoses and connection cable needs to follow the slanted edge on the corner of the housing.
The mains socket needs to be planned outside of the built-in niche.

Please read the installation details regarding air ducting on page 8–9.

Connection

Total connected load 2.9 kW.
Only cold water connection.
Inlet hose 3.0 m with 3/4" (26.4 mm) connection, extendable.
Outlet hose (ø 25 mm) 3.0 m (HT-Hose).
Power requirements
220 – 240 V / 50 Hz.
Plan a connection cable.

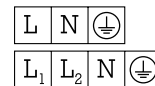

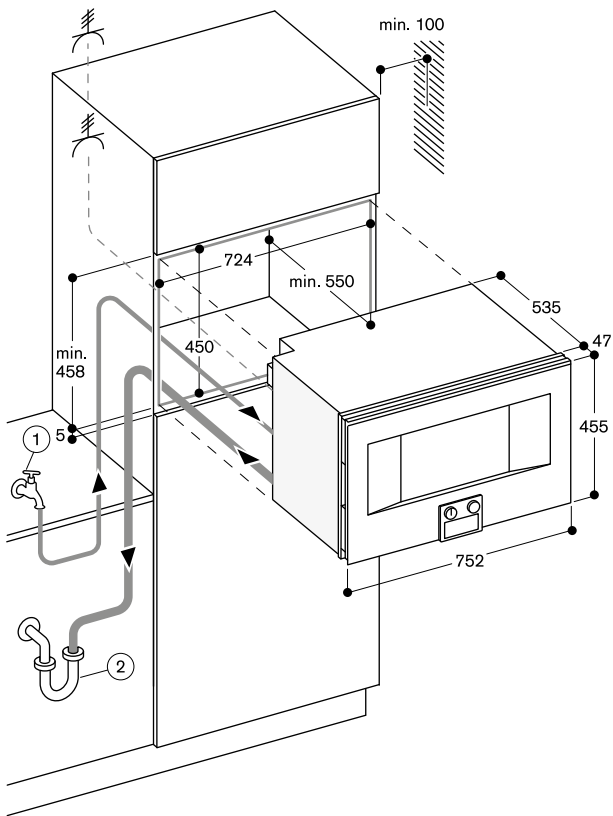

Side view of BS 484/485 above BO

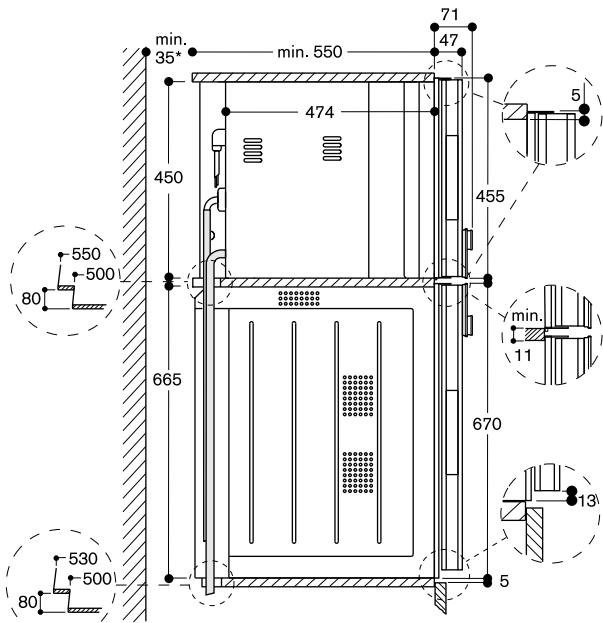

* Only required if the water hoses for the BS steam oven cannot be accommodated in the corner recesses of the appliances.

Drainage connection

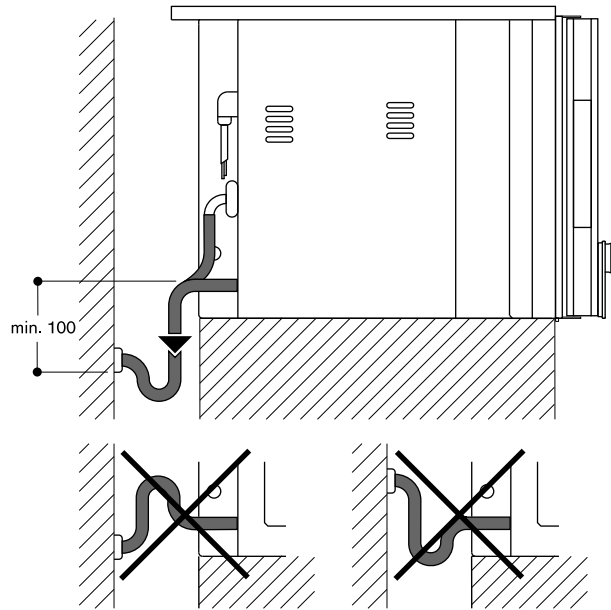

View from the back

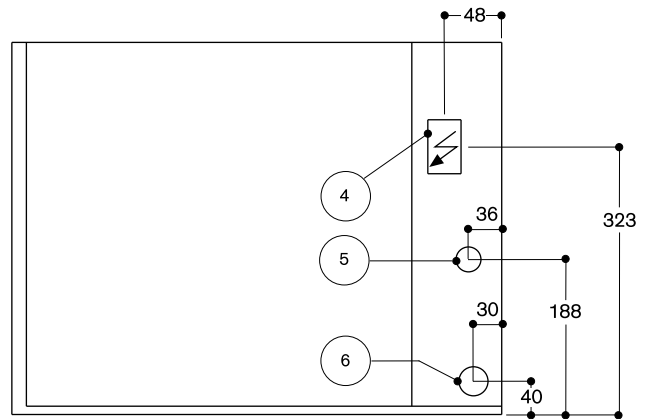

- (4) electric terminal box
- (5) cold-water connection
- (6) water outlet



Controls at the top

Right-hinged

BS 470 111

Stainless steel-backed full glass door
Width 60 cm

Left-hinged

BS 471 111

Stainless steel-backed full glass door
Width 60 cm

Controls at the bottom

Right-hinged

BS 474 111

Stainless steel-backed full glass door
Width 60 cm

Left-hinged

BS 475 111

Stainless steel-backed full glass door
Width 60 cm

Included in the price

- 1 Gastronorm insert, stainless steel, GN 2/3 unperforated
- 1 Gastronorm insert, stainless steel, GN 2/3 perforated
- 1 wire rack
- 1 plug-in core temperature probe
- 4 Cleaning cartridge
- 1 outlet hose (3 m long)
- 1 water inlet hose (3 m long)

Special accessories

CL S10 040

Cleaning cartridges, set of 4
For combi-steam oven with fixed inlet and outlet water connection.

CL S20 040

Descaling cartridges, set of 4
For combi-steam oven with fixed inlet and outlet water connection

GN 144 230

Gastronorm insert, non-stick, GN 2/3 Unperforated, 40 mm deep, 3l.

GN 154 230

Gastronorm insert, non-stick, GN 2/3 Perforated, 40 mm deep, 3l.

GN 340 230

Gastronorm roaster in cast aluminium. GN 2/3, height 165 mm, non-stick.

GN 410 230

Gastronorm lid, stainless steel, GN 2/3.

Combi-steam oven 400 series

BS 470/BS 471/BS 474/BS 475

- Proud mounted installation
- Handleless door / automatic door opening
- Fixed inlet and outlet water connection
- Cleaning system, fully automatic
- Hot air 30 °C to 230 °C can be combined with chosen humidity level of 0%, 30%, 60%, 80% or 100%
- Sous-vide cooking with accurate temperature regulation
- Full surface grill behind glass ceramic, combinable with circulated air up to 230 °C and steam
- TFT touch display
- Panel-free appliance with surface control module
- Steaming without pressure
- Electronic temperature control from 30 °C to 230 °C
- Core temperature probe, removable
- Net volume 44 litres
- Energy efficiency class A

Heating methods

Hot air + 100 % humidity.

Hot air + 80 % humidity.

Hot air + 60 % humidity.

Hot air + 30 % humidity.

Hot air + 0 % humidity.

Low temperature cooking.

Sous-vide cooking.

Full surface grill level 1 + humidity.

Full surface grill level 2 + humidity.

Full surface grill + circulated air.

Full surface grill.

Defrosting.

Regenerating.

Handling

Automatic door opening.

Rotary knob and TFT touch display operation.

Clear text display in 25 languages.

Option to save 50 individual recipes (incl. core temperature probe).

Information key with use indicators.

Side-opening door opens up to 180° angle.

Features

Full surface grill 2000 W behind glass ceramic.

Steam removal.

Misting.

Core temperature probe with automatic shut-off.

Actual temperature display.

Timer functions: cooking time, cooking time end, timer, stopwatch, long-term timer.

Electronic boiling point detection.

48 W halogen light on the side.

Hygienic stainless steel cooking interior.

4 tray levels.

Safety

Child lock.

Safety shut-off.

Cooled housing with temperature protection.

Cleaning

Cleaning program, fully automatic.

Descaling program, fully automatic.

Drying program.

Strainer filter, removable.

Demo cleaning program.

Planning notes

Door hinge not reversible.

No other electrical appliances should be installed above the BS.

At no point may the outlet hose be positioned higher than the bottom edge of the appliance. The outlet hose must also be at least 100 mm lower than the appliance outlet (see drawing "drainage connection").

Inlet hose can be extended once.

The outlet hose must not be longer than a maximum of 5 m.

The water connection (1) for the inlet hose must always be accessible and not located directly behind the appliance.

The connection of the outlet hose to the siphon (2) must not be directly behind the appliance and should be accessible.

The door panel surface of the appliance extends 47 mm from the furniture cavity.

Consider the overhang, incl. the door handle where applicable, when planning to open drawers next to the appliance.

When planning a corner solution, pay attention to the 90° door opening angle.

To achieve the 550 mm installation depth, the water hoses and connection cable needs to follow the slanted edge on the corner of the housing.

The mains socket needs to be planned outside of the built-in niche.

Please read the installation details regarding air ducting on page 8–9.

Connection

Total connected load 2.9 kW.

Only cold water connection.

Inlet hose 3.0 m with 3/4" (26.4 mm) connection, extendable.

Outlet hose (ø 25 mm) 3.0 m (HT-Hose).

Power requirements

220 – 240 V / 50 Hz.

Plan a connection cable.

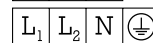
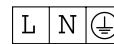

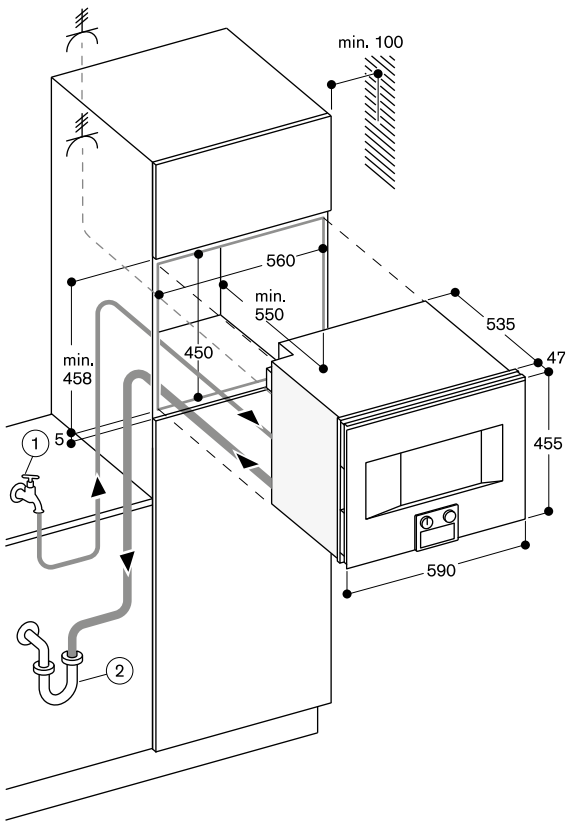

Side view of BS 474/475 above BO

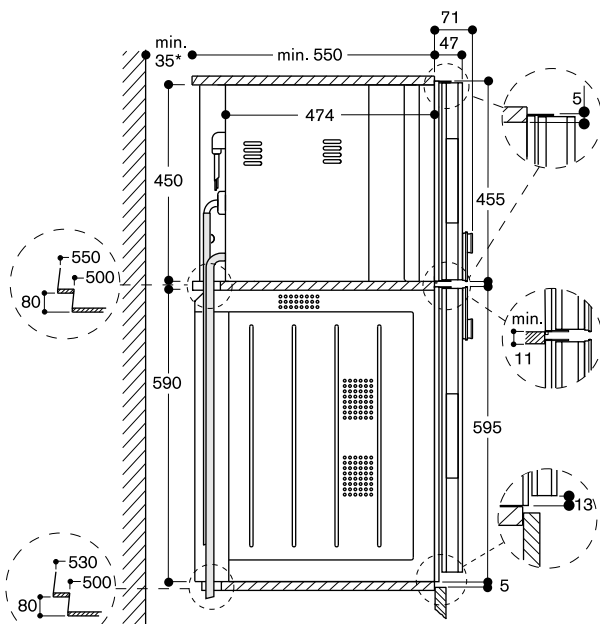

* Only required if the water hoses for the BS steam oven cannot be accommodated in the corner recesses of the appliances.

Drainage connection

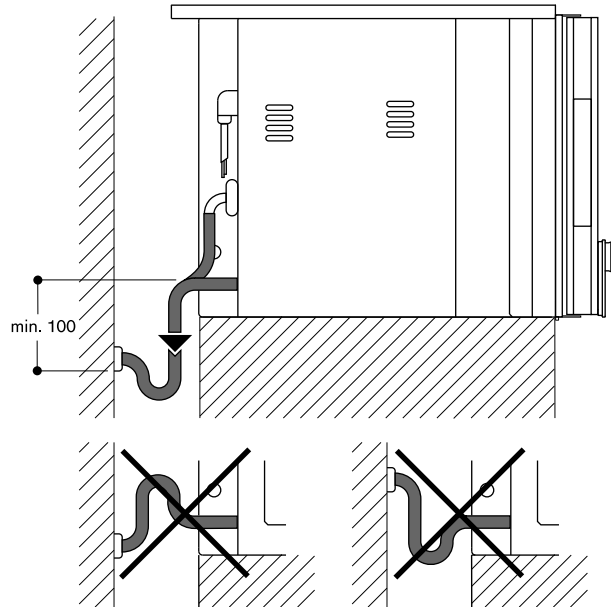

View from the back

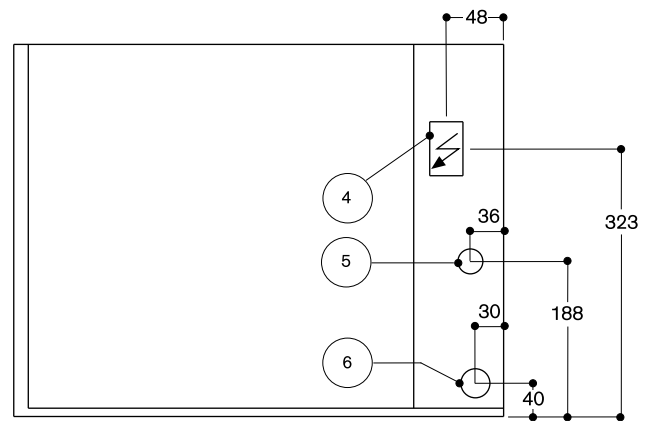

- (4) electric terminal box
- (5) cold-water connection
- (6) water outlet



▲ Commercial exclusive model

Controls at the bottom

Right-hinged

BS 454 110

Stainless steel-backed full glass door

Width 60 cm

Left-hinged

BS 455 110

Stainless steel-backed full glass door

Width 60 cm

Included in the price

- 1 Gastronorm insert, stainless steel, GN2/3 unperforated
- 1 Gastronorm insert, stainless steel, GN2/3 perforated
- 1 wire rack
- 1 plug-in core temperature probe

Special accessories

GN 144 230

Gastronorm insert, non-stick, GN2/3 Unperforated, 40 mm deep, 3l.

GN 154 230

Gastronorm insert, non-stick, GN2/3 Perforated, 40 mm deep, 3l.

GN 340 230

Gastronorm roaster in cast aluminium. GN2/3, height 165 mm, non-stick.

GN 410 230

Gastronorm lid, stainless steel, GN2/3.

Combi-steam oven 400 series

BS 454/BS 455

- Proud mounted installation
- Handleless door / automatic door opening
- Water tank
- Hot air 30 °C to 230 °C can be combined with chosen humidity level of 0%, 30%, 60%, 80% or 100%
- TFT touch display
- Panel-free appliance with surface control module
- Steaming without pressure
- Electronic temperature control from 30 °C to 230 °C
- Core temperature probe, removable
- Net volume 42 litres
- Energy efficiency class A

Heating methods

- Hot air + 100 % humidity.
- Hot air + 80 % humidity.
- Hot air + 60 % humidity.
- Hot air + 30 % humidity.
- Hot air + 0 % humidity.
- Dough proving.
- Defrosting.
- Regenerating.
- Low temperature cooking.

Handling

- Automatic door opening.
- Rotary knob and TFT touch display operation.
- Clear text display in 25 languages.
- Option to save 50 individual recipes (incl. core temperature probe).
- Information key with use indicators.
- Side-opening door opens up to 180° angle.

Features

- Removable 1.3 litre water tank.
- Water level warning.
- Core temperature probe with automatic shut-off.
- Actual temperature display.
- Timer functions: cooking time, cooking time end, timer, stopwatch, long-term timer.
- Electronic boiling point detection.
- 48 W halogen light on the side.
- Hygienic stainless steel cooking interior.
- 4 tray levels.

Safety

- Child lock.
- Safety shut-off.
- Cooled housing with temperature protection.

Cleaning

- Cleaning aid.
- Drying program.
- Descaling program.
- Grease filter, dishwasher-safe.

Planning notes

- Door hinge not reversible.
- No other electrical appliances should be installed above the BS.
- The door panel surface of the appliance extends 47 mm from the furniture cavity.
- Consider the overhang, incl. the door handle where applicable, when planning to open drawers next to the appliance.

When planning a corner solution, pay attention to the 90° door opening angle.

To achieve the 550 mm installation depth, the connection cable needs to follow the slanted edge on the corner of the housing.

The mains socket needs to be planned outside of the built-in niche.

Please read the installation details regarding air ducting on page 8–9.

Connection

Total connected load 2.0 kW.

Power requirements

220 – 240 V / 50 – 60 Hz.

Plan a connection cable.

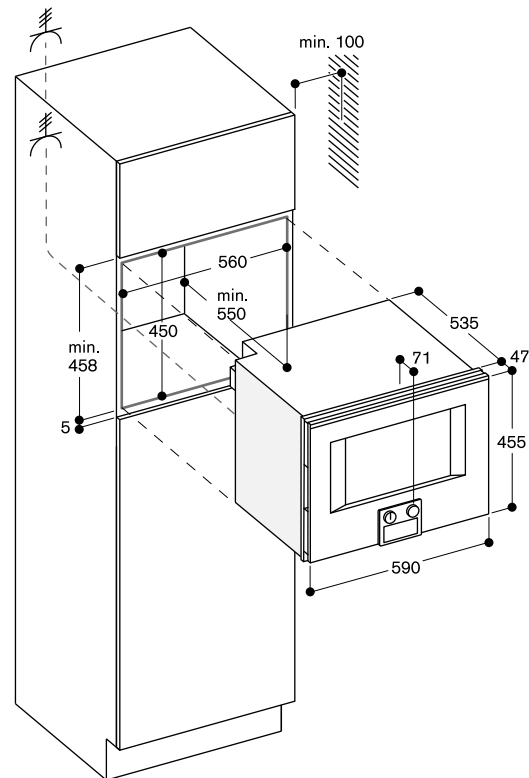
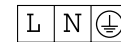

Side view of BS 454/455, BM 454/455 above BO

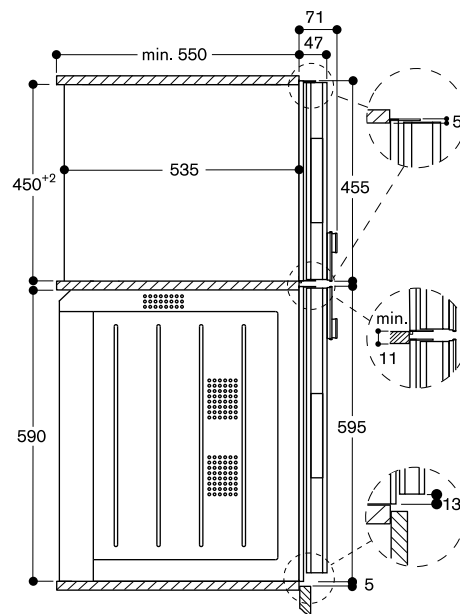





Controls at the bottom

Right-hinged

BM 484 110

Stainless steel-backed full glass door

Width 76 cm

Left-hinged

BM 485 110

Stainless steel-backed full glass door

Width 76 cm

Included in the price

1 combination wire rack

1 glass tub

Combi-microwave oven 400 series

BM 484/BM 485

- Proud mounted installation
- Handleless door / automatic door opening
- Single operation and combination of microwave, grill and oven
- Sequential operation of up to 5 modes incl. programming of combined operation and rest time
- TFT touch display
- Panel-free appliance with surface control module
- Electronic temperature control
- Interior volume 36 litres

Programs

Microwave operation with 5 output levels: 1000, 600, 360, 180, 90 W.

Oven operation with 4 heating methods:

Hot air 40 °C and from 100 °C to 250 °C,

Full surface grill + hot air from 100 °C to 250 °C,

Full surface grill + circulated air from 100 °C to 250 °C,

Full surface grill with 3 levels of intensity, maximum output 2000 W.

Heating methods with microwave output levels 600, 360, 180 and 90 W freely combinable.

15 automatic programs with weight indication, customisable:

4 defrosting programs

4 cooking programs

7 combination programs

Handling

Automatic door opening.

Rotary knob and TFT touch display operation.

Clear text display in 25 languages.

Option to save 50 individual recipes.

Information key with use indicators.

Side-opening door opens up to 180° angle.

Features

Innowave.

Rapid heating.

4 tray levels.

Actual temperature display.

60 W halogen light on the side.

Safety

Thermally insulated door with triple glazing.

Triple door lock.

Child lock.

Safety shut-off.

Cooled housing with temperature protection.

Cleaning

Hygienic stainless steel interior with glass ceramic base.

Interior back wall with catalytic coating.

Planning notes

Door hinge not reversible.

The door panel surface of the appliance extends 47 mm from the furniture cavity.

If the handle (optional accessory) is retrofitted, the outer edge of the door handle extends 94 mm from the furniture cavity.

Consider the overhang, incl. the door handle where applicable, when planning to open drawers next to the appliance.

When planning a corner solution, pay attention to the 110° door opening angle.

The mains socket needs to be planned outside of the built-in niche.

Please read the installation details regarding oven combination on page 8–9.

Connection

Total connected load 3.1 kW.

Connection cable 1.5 m without plug.

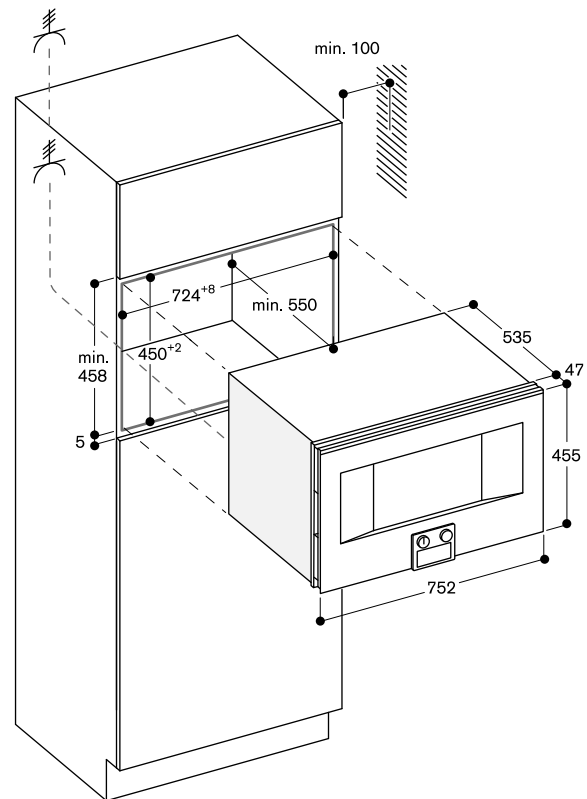
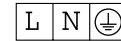

Side view of BM 484/485 above BO

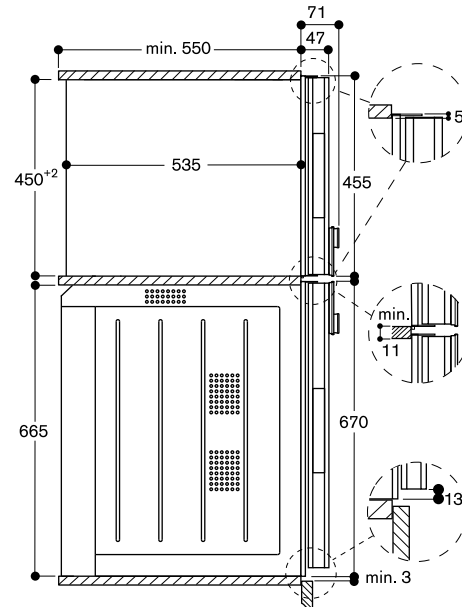



Controls at the bottom

Right-hinged

BM 454 110

Stainless steel-backed full glass door

Width 60 cm

Left-hinged

BM 455 110

Stainless steel-backed full glass door

Width 60 cm

Included in the price

1 combination wire rack

1 glass tub

Combi-microwave oven 400 series

BM 454/BM 455

- Proud mounted installation
- Handleless door / automatic door opening
- Single operation and combination of microwave, grill and oven
- Sequential operation of up to 5 modes incl. programing of combined operation and rest time
- TFT touch display
- Panel-free appliance with surface control module
- Electronic temperature control
- Interior volume 36 litres

Programs

Microwave operation with 5 output levels: 1000, 600, 360, 180, 90 W.

Oven operation with 4 heating methods:

Hot air 40 °C and from

100 °C to 250 °C,

Full surface grill + hot air from

100 °C to 250 °C,

Full surface grill + circulated air from

100 °C to 250 °C

Full surface grill with 3 levels of intensity, maximum output 2000 W.

Heating methods with microwave output levels 600, 360, 180 and 90 W freely combinable.

15 automatic programs with weight indication, customisable:

4 defrosting programs

4 cooking programs

7 combination programs

Handling

Automatic door opening.

Rotary knob and TFT touch display operation.

Clear text display in 25 languages.

Option to save 50 individual recipes.

Information key with use indicators.

Side-opening door opens up to 180° angle.

Features

Innowave.

Rapid heating.

4 tray levels.

Actual temperature display.

60 W halogen light on the side.

Safety

Thermally insulated door with triple glazing.

Triple door lock.

Child lock.

Safety shut-off.

Cooled housing with temperature protection.

Cleaning

Hygienic stainless steel interior with glass ceramic base.

Interior back wall with catalytic coating.

Planning notes

Door hinge not reversible.

Plan the niche without back wall.

The door panel surface of the appliance extends 47 mm from the furniture cavity.

Consider the overhang, incl. the door handle where applicable, when planning to open drawers next to the appliance.

When planning a corner solution, pay attention to the 110° door opening angle.

The mains socket needs to be planned outside of the built-in niche.

Please read the installation details regarding air ducting on page 8-9.

Connection

Total connected load 3.1 kW.

Power requirements

220 – 240 V / 50 – 60 Hz.

Connection cable 1.5 m without plug.

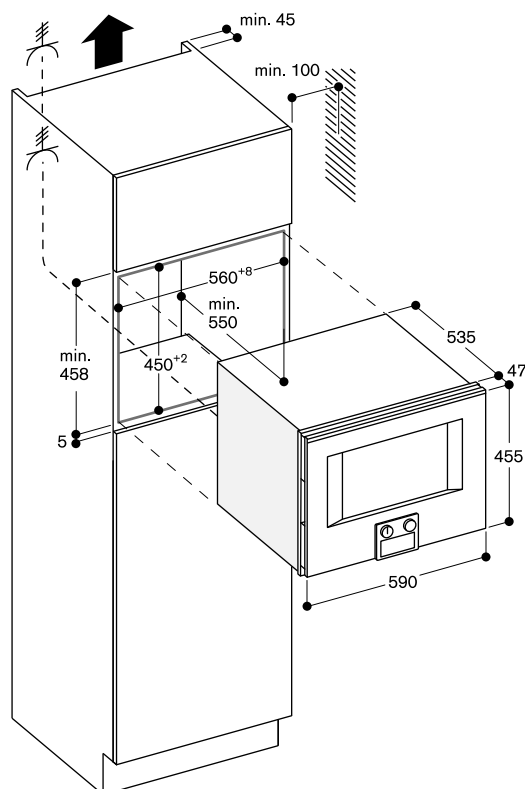

Side view of BS 454/455, BM 454/455 above BO

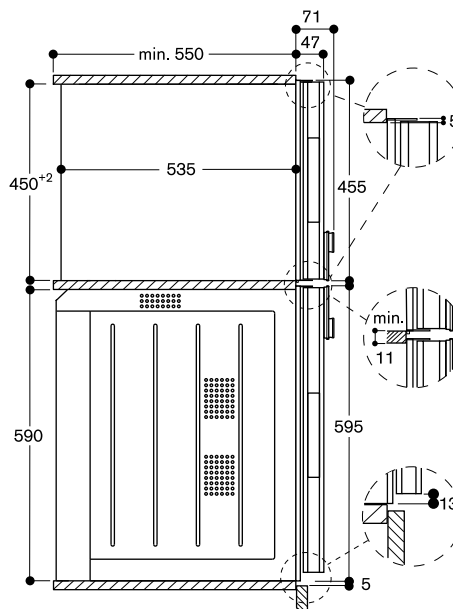



Controls at the top

Left-hinged

CM 470 111

Stainless steel-backed full glass door
Width 60 cm

Included in the price

- 1 assembly screws
- 1 scoop
- 1 test strip
- 1 milk container (insulated)
- 1 connection hose for milk frother
- 1 milk tube

Fully automatic coffee machine

400 series

CM 470

- Proud mounted installation
- Handleless door / automatic door opening
- Fixed inlet and outlet water connection
- Continuous flow heater means no waiting time and constant brewing temperature
- Aroma brewing technology for a full aroma
- Single portion cleaning
- TFT touch display
- Panel-free appliance with surface control module
- One-touch operation
- Personalisation function
- Seven light settings
- Electronic fill level control for milk, water and coffee to ensure a perfect result

Type of beverage

Ristretto / 2 x Ristretto.
Espresso / 2 x Espresso.
Espresso Macchiato / 2 x Espresso Macchiato.
Coffee / 2 x Coffee.
Americano / 2 x Americano.
Caffe Latte / 2 x Caffe Latte.
Latte Macchiato / 2 x Latte Macchiato.
Cappuccino / 2 x Cappuccino.
Flat White / 2 x Flat White.
Milk froth / 2 x Milk froth.
Warm milk / 2 x Warm milk.
Hot water / 2 x Hot water.

Handling

Automatic door opening.
Rotary knob and TFT touch display operation.
Clear text display in 25 languages.
Personalisation function, option to save 8 individualised beverages.
4 beverage size settings, volume can be individually adjusted to match the size of the cup.
8 coffee strength levels from very mild to extra strong.
3 coffee temperature levels.
10 hot water temperature levels.
4 coffee-milk ratio levels.
Adjustable grinding level.
Height-adjustable coffee dispenser 7 cm to 15 cm.
Easy access to water tank, milk and coffee bean container behind the door.

Features

Maintenance-free grinding unit with ceramic discs.
Separate drawer for second ground coffee type.
Water pump with 19 bar pressure.
Double grinding and brewing cycles for extra intensity for single beverage order.
For double beverage order, two grinding and brewing cycles.
Beverage dispenser with integrated milk system.
Insulated stainless steel milk container for up to 0.5 litres.
Integrated lightning with LEDs.
Removable bean container with aroma protecting lid for 500 g allows for an

effortless exchange of different types of coffee beans.
Automatic adjustment of ground coffee quantity.
Removable 2.4 litre water tank.
Electronic water filter exchange indicator.
Fresh water-function to refill the water tank with fresh water.
Electronic fill level control for drip tray and container for coffee residue.

Safety

Child lock.
Aqua stop with guarantee.

Cleaning

Fully automatic rinse program when machine is turned on/off.
Automatic steam cleaning of the milk system after every beverage.
Automatic cleaning and descaling program.
Emptying program to prepare the appliance for holiday or transportation.
Empty-grinding function to remove coffee residues from the system when switching bean types.
Removable brewing unit.
Dishwasher-safe coffee residue container and drip tray.
Dishwasher-safe beverage dispenser.

Planning notes

Ideal installation height 95 – 145 cm (top edge of niche bottom).
The facade of the appliance extends 47 mm from the furniture cavity.
When installing in a corner a side clearance is required.
Door opening angle appr. 110° (delivery status) - mounting distance to the wall has to be at least 350 mm.
Door opening angle appr. 155° - mounting distance to the wall has to be at least 650 mm.
Door opening angle appr. 92° - mounting distance to the wall has to be at least 100 mm (spare part No. 00636455).
Installation directly above 14 cm high warming drawer in 59 cm standardised niche.
At no point may the outlet hose be positioned higher than the bottom edge of the appliance. The outlet hose must also be at least 150 mm lower than the appliance outlet (see drawing "drainage connection").
If the appliance is placed too far from the main siphon, the drain system has to be adjusted on-site (building installation).
The water connection (1) for the inlet hose must always be accessible and not located directly behind the appliance.
The connection of the outlet hose to the siphon (2) must not be directly behind the appliance and should be accessible.
Special accessories (order as spare parts):
Part No. 17000705 Water filter
Part No. 00311819 Descaling tablets
Part No. 00311769 Cleaning tablets
Part No. 00636455 Door hinge restrictor (92° opening angle)
Part No. 11015223 Bean container with lid

Connection

Total connected load 1.6 kW.
Connection cable 1.7 m with plug.
Only cold water connection.
Inlet hose 165 cm with 3/4" (26.4 mm) connection,
Outlet hose (ø 18 mm) 170 cm (HT-Hose).

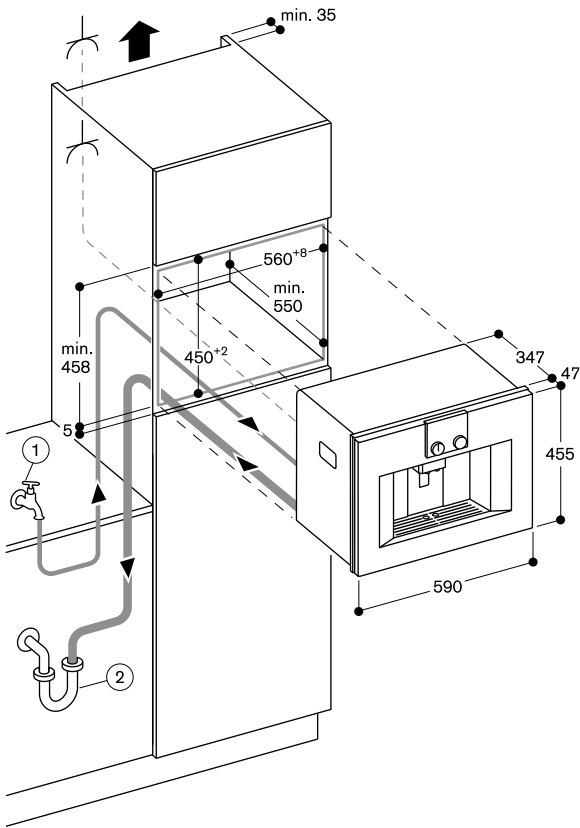

View from rear

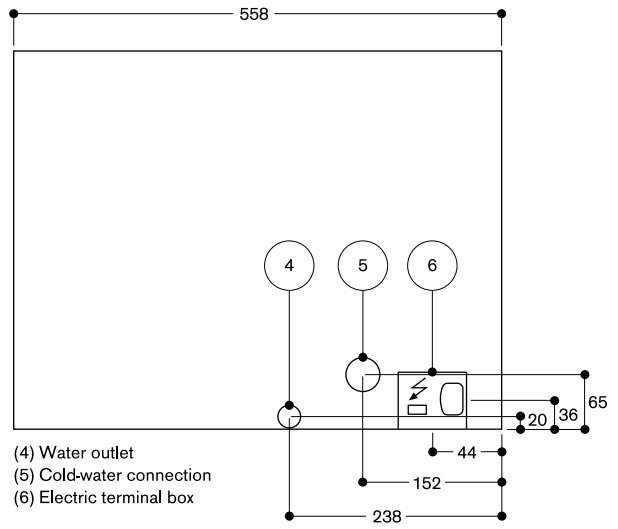

Drainage connection

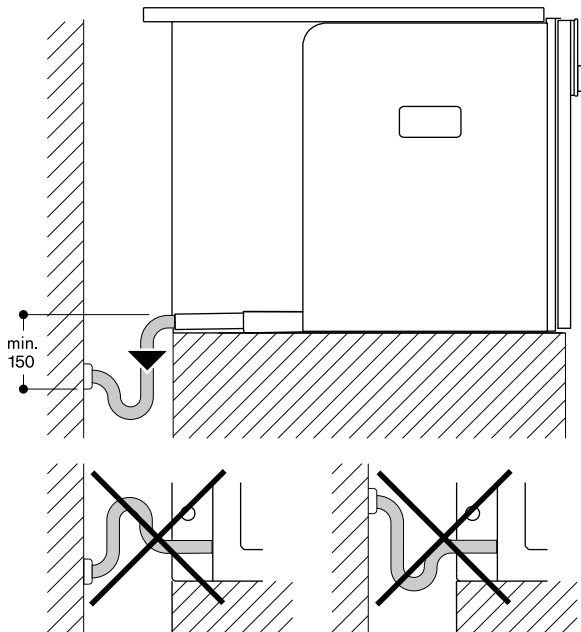



Controls at the top

Left-hinged

CM 450 111

Stainless steel-backed full glass door
Width 60 cm

Included in the price

- 1 assembly screws
- 1 scoop
- 1 test strip
- 1 milk container (insulated)
- 1 connection hose for milk frother
- 1 milk tube

Fully automatic coffee machine

400 series

CM 450

- Proud mounted installation
- Handleless door / automatic door opening
- Continuous flow heater means no waiting time and constant brewing temperature
- Aroma brewing technology for a full aroma
- Single portion cleaning
- TFT touch display
- Panel-free appliance with surface control module
- One-touch operation
- Personalisation function
- Water tank
- Seven light settings
- Electronic fill level control for milk, water and coffee to ensure a perfect result

Type of beverage

Ristretto / 2 x Ristretto.
Espresso / 2 x Espresso.
Espresso Macchiato / 2 x Espresso Macchiato.
Coffee / 2 x Coffee.
Americano / 2 x Americano.
Caffe Latte / 2 x Caffe Latte.
Latte Macchiato / 2 x Latte Macchiato.
Cappuccino / 2 x Cappuccino.
Flat White / 2 x Flat White.
Milk froth / 2 x Milk froth.
Warm milk / 2 x Warm milk.
Hot water / 2 x Hot water.

Handling

Automatic door opening.
Rotary knob and TFT touch display operation.
Clear text display in 25 languages.
Personalisation function, option to save 8 individualised beverages.
4 beverage size settings, volume can be individually adjusted to match the size of the cup.
8 coffee strength levels from very mild to extra strong.
3 coffee temperature levels.
10 hot water temperature levels.
4 coffee-milk ratio levels.
Adjustable grinding level.
Height-adjustable coffee dispenser 7 cm to 15 cm.
Easy access to water tank, milk and coffee bean container behind the door.

Features

Maintenance-free grinding unit with ceramic discs.
Separate drawer for second ground coffee type.
Water pump with 19 bar pressure.
Double grinding and brewing cycles for extra intensity for single beverage order.
For double beverage order, two grinding and brewing cycles.
Beverage dispenser with integrated milk system.
Insulated stainless steel milk container for up to 0.5 litres.
Integrated lightning with LEDs.
Removable bean container with aroma protecting lid for 500 g allows for an effortless exchange of different types of coffee beans.
Automatic adjustment of ground coffee quantity.
Removable 2.4 litre water tank.
Electronic water filter exchange indicator.

Electronic fill level control for drip tray and container for coffee residue.

Safety

Child lock.

Cleaning

Fully automatic rinse program when machine is turned on/off.
Automatic steam cleaning of the milk system after every beverage.
Automatic cleaning and descaling program.
Emptying program to prepare the appliance for holiday or transportation.
Empty-grinding function to remove coffee residues from the system when switching bean types.
Removable brewing unit.
Dishwasher-safe coffee residue container and drip tray.
Dishwasher-safe beverage dispenser.

Planning notes

Ideal installation height 95 – 145 cm (top edge of niche bottom).
The facade of the appliance extends 47 mm from the furniture cavity.
When installing in a corner a side clearance is required.
Door opening angle appr. 110° (delivery status) - mounting distance to the wall has to be at least 350 mm.
Door opening angle appr. 155° - mounting distance to the wall has to be at least 650 mm.
Door opening angle appr. 92° - mounting distance to the wall has to be at least 100 mm (spare part No. 00636455).
Installation directly above 14 cm high warming drawer in 59 cm standardised niche.
Special accessories (order as spare parts):
Part No. 17000705 Water filter
Part No. 00311819 Descaling tablets
Part No. 00311769 Cleaning tablets
Part No. 00636455 Door hinge restrictor (92° opening angle)
Part No. 11015223 Bean container with lid

Please read the installation details regarding air ducting on page 8–9.

Connection

Total connected load 1.6 kW.
Connection cable 1.7 m with plug.

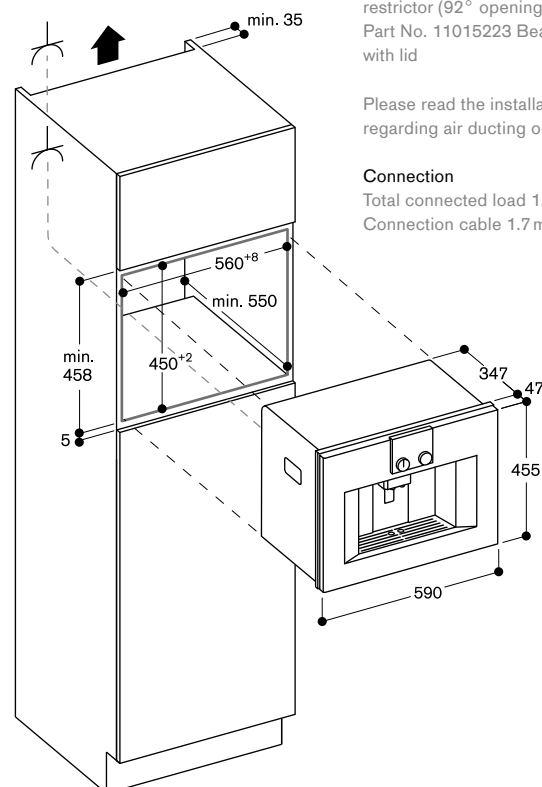

**WS 482 110**

Stainless steel-backed glass front
Width 76 cm, Height 21 cm

**Warming drawer 400 series
WS 482**

- Proud mounted installation
- Handleless drawer
- Bright interior light
- Cushioned closing system
- Hygienic stainless steel interior with glass bottom
- 4 power levels in the temperature range 40 °C to 80 °C (glass surface)
- Also for preparing and cooking meals, and for keeping meals warm

Heating methods

Defrosting of meals/proving of yeast dough.
Preheating of small beverage containers.
Keeping meals warm/slow cooking meals.
Warming ovenware.

Handling

Rotary knob operation.
Recessed grip at the front bottom of the drawer.

Features

Net volume 38 litres.
Volume capacity: Dinner service for 10 people including ø 24 cm plates and soup bowls, additional bowls and a serving dish depending on size.
Max. load 25 kg.
Usable interior dimensions W 606 x H 132 x D 480 mm.
Heating under glass bottom for easy cleaning.
Fan for even heat distribution for fast warming ovenware.
Status display, visible in the glass front.
Glass bottom made of safety glass.

Planning notes

The panel surface of the appliance extends 47 mm from the furniture cavity.
Installation of BO/BS above WS with dimensionally stable intermediate shelf.
Installation of BS above WS in 66.5 cm niche with intermediate floor (gap of 7 mm between WS and BS).
The socket can be planned behind the appliance.

Please read the installation details regarding air ducting on page 8–9.

Connection

Total connected load 0.81 kW.
Power requirements
220 – 240 V / 50 – 60 Hz.
Connection cable 1.5 m, with plug.

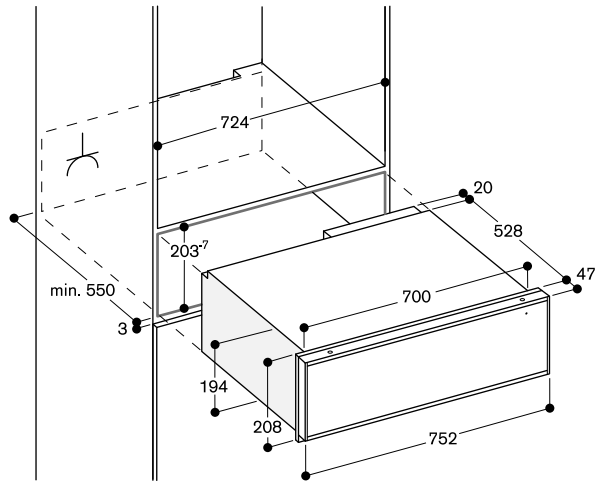
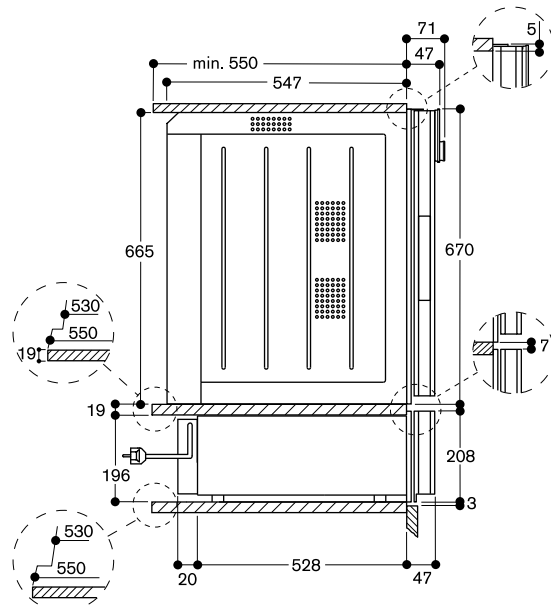
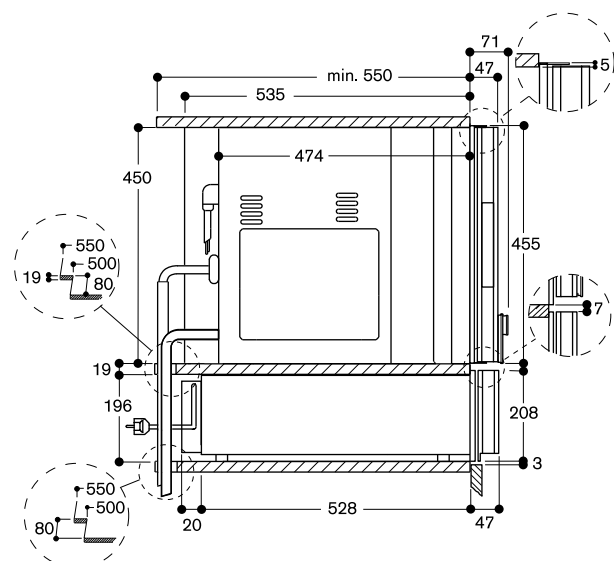
**Side view of WS 482 below BO 480****Side view of WS 482 below BS 484/485**



WS 462 110

Stainless steel-backed glass front
Width 60 cm, Height 29 cm

Warming drawer 400 series

WS 462

- Proud mounted installation
- Handleless drawer
- Bright interior light
- Cushioned closing system
- Hygienic stainless steel interior with glass bottom
- 4 power levels in the temperature range 40 °C to 80 °C (glass surface)
- Also for preparing and cooking meals, and for keeping meals warm

Heating methods

Defrosting of meals/proving of yeast dough.

Preheating of small beverage containers.

Keeping meals warm/slow cooking meals.

Warming ovenware.

Handling

Rotary knob operation.

Recessed grip at the front bottom of the drawer.

Features

Net volume 51 litres.

Volume capacity: Dinner service for 12 people including ø 24 cm plates and soup bowls, additional bowls and a serving dish depending on size.

Max. load 25 kg.

Usable interior dimensions
W 475 x H 236 x D 458 mm.

Heating under glass bottom for easy cleaning.

Fan for even heat distribution for fast warming ovenware.

Status display, visible in the glass front.

Glass bottom made of safety glass.

Planning notes

The panel surface of the appliance extends 47 mm from the furniture cavity.

The socket can be planned behind the appliance.

Please read the installation details regarding air ducting on page 8–9.

Connection

Total connected load 0.81 kW.

Power requirements

220 – 240 V / 50 – 60 Hz.

Connection cable 1.5 m, with plug.

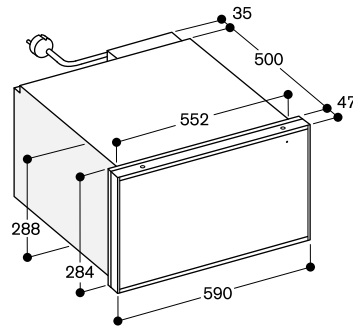

Side view of WS 462 below BO

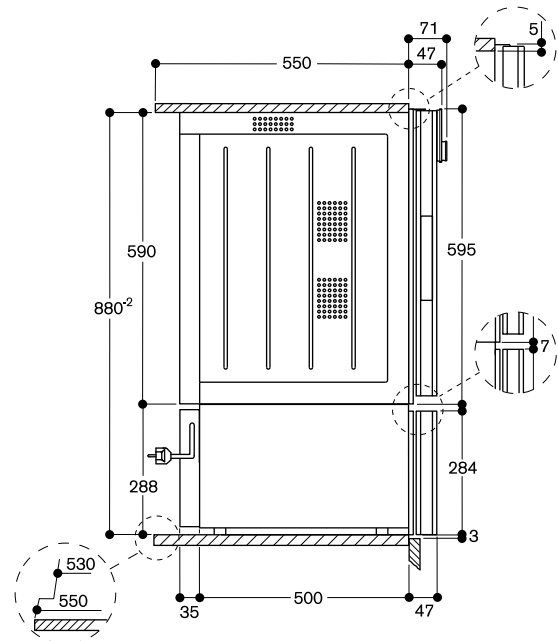

**WS 461 110**

Stainless steel-backed glass front
Width 60 cm, Height 14 cm

Warming drawer 400 series
WS 461

- Proud mounted installation
- Handleless drawer
- Bright interior light
- Cushioned closing system
- Hygienic stainless steel interior with glass bottom
- 4 power levels in the temperature range 40 °C to 80 °C (glass surface)
- Also for preparing and cooking meals, and for keeping meals warm

Heating methods

Defrosting of meals/proving of yeast dough.
Preheating of small beverage containers.
Keeping meals warm/slow cooking meals.
Warming ovenware.

Handling

Rotary knob operation.
Recessed grip at the front bottom of the drawer.

Features

Net volume 19 litres.
Volume capacity: Dinner service for 6 people including ø 24 cm plates and soup bowls, additional bowls and a serving dish depending on size.
Max. load 25 kg.
Usable interior dimensions W 475 x H 86 x D 458 mm.
Heating under glass bottom for easy cleaning.
Fan for even heat distribution for fast warming ovenware.
Status display, visible in the glass front.
Glass bottom made of safety glass.

Planning notes

The panel surface of the appliance extends 47 mm from the furniture cavity.
Installation of BS/BM/CM directly above WS in 59 cm niche without intermediate floor.
The socket can be planned behind the appliance.

Please read the installation details regarding air ducting on page 8–9.

Connection

Total connected load 0.81 kW.
Power requirements
220 – 240 V / 50 – 60 Hz.
Connection cable 1.5 m, with plug.

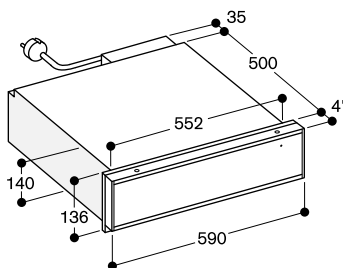
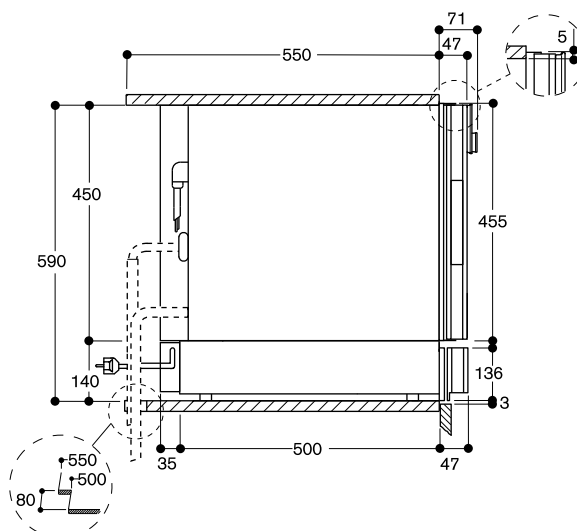
Side view of WS 461 below BS, BM, CM



DV 461 110

Stainless steel-backed glass front
Width 60 cm, Height 14 cm

Included in the price

- 1 Vacuuming bag, small (50 pcs.)
- 1 Vacuuming bag, large (50 pcs.)
- 1 Raised vacuuming platform
- 1 Adaptor for vacuuming outside the chamber
- 1 Vacuuming hose
- 1 Adaptor for bottle plugs
- 3 Plugs for vacuuming of bottles

Special accessories

BA 080 670

Vacuuming bags, small
180 x 280 mm, 100 pcs.

BA 080 680

Vacuuming bags, large
240 x 350 mm, 100 pcs.

Vacuuming drawer 400 series

DV 461

- Proud mounted installation
- Hygienic stainless steel vacuuming chamber, applicable height up to 80 mm
- 3 vacuuming levels for vacuuming in the chamber, max. 99%
- 3 vacuuming levels for vacuuming outside the chamber, max. 90%
- Automatic connection recognition for vacuuming outside the chamber
- Handleless drawer
- Cushioned closing system

Application

Vacuuming for sous-vide cooking.
Vacuuming for fast marinating and flavouring.

Vacuuming for extended storage.

Vacuuming of vacuuming containers outside the chamber.

Vacuuming of liquids in bottles outside the chamber.

Handling

Touch key operation.
Recessed grip at the front bottom of the drawer.

Features

Net volume 7.7 litres.
Capacity load max. 10 kg.
Maximum size of vacuuming bags
W 240 mm x L 350 mm.
3 heat-sealing levels for different strengths of bag material.
Sealing bar, non-stick coating, removable.
Safety glass cover, opens automatically after vacuuming.
Raised vacuuming platform, 44 mm, deployable.
Utility space in vacuuming chamber, W 210 mm x L 275 mm.
Membrane for avoiding reflux of liquids during vacuuming outside the chamber.
Drying program for vacuuming pump.
Warning function.

Planning notes

The panel surface of the appliance extends 47 mm from the furniture cavity.
Installation of BS/BM/CM directly above DV in 59 cm niche without intermediate floor.
Built-in under worktop or in single niche.
The socket can be planned behind the appliance.

Please read the installation details regarding air ducting on page 8–9.

Connection

Total connected load 0.32 kW.
Power requirements
220 – 240 V / 50 – 60 Hz.
Connecting cable 1.5 m with plug.

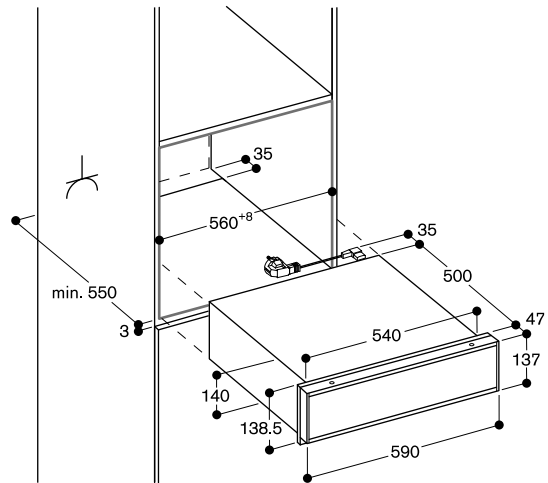

Side view of DV 461 below BS, BM, CM

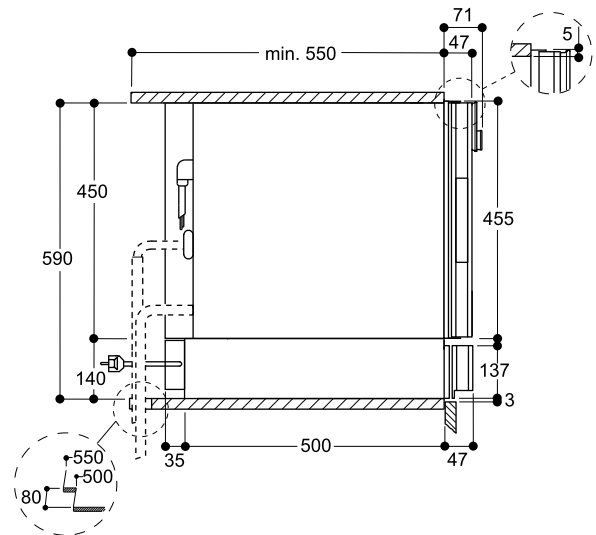

Accessories and special accessories 400 series

BA 016 105

Pull-out system
Fully extendable telescopic rails
and enamelled cast iron frame.



BA 018 105

Pull-out system
Fully extendable telescopic rails
and enamelled cast iron frame.

BA 056 115

Heating element for baking stone
and Gastronorm roaster



BA 058 115

Heating element for baking stone
and Gastronorm roaster

BA 056 133

Baking stone
Incl. baking stone support and
pizza paddle (heating element must
be ordered separately). Not in
combination with pull-out system.



BA 058 133

Baking stone
Incl. baking stone support and pizza
paddle (heating element must be
ordered separately). Not in combina-
tion with pull-out system.

CL S10 040

Cleaning cartridges, Set of 4.
For Combi-steam oven with fixed inlet
and outlet water connection.



CL S20 040

Descaling cartridges, Set of 4.
For Combi-steam oven with fixed inlet
and outlet water connection.



BA 080 670

Vacuuming bags, small
180 x 280 mm, 100 pcs.



BA 080 680

Vacuuming bags, large
240 x 350 mm, 100 pcs.



GN 144 230

Gastronorm insert, GN 2/3, non-stick,
Unperforated, 40 mm deep, 3 l.



GN 154 230

Gastronorm insert, GN 2/3, non-stick,
Perforated, 40 mm deep, 3 l.

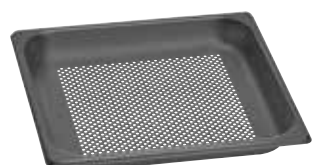

GN 340 230

Gastronorm roaster in cast aluminium
GN 2/3, height 165 mm, non-stick
For roasting in oven with roasting
function.

Lower and upper part can also be
used separately, height 100 and
65 mm.

For ovens with pull-out system
BA 016 or BA 018 (order heating
element separately) and Combi-steam
ovens.



GN 410 230

Gastronorm lid, stainless steel, GN 2/3
For stainless steel gastronorm inserts.



Advice:

Not every illustrated accessory fits to every oven.



The ovens 200 series

Checklist for appliance combinations 200 series	32
Ovens 200 series	34
Combi-steam ovens 200 series	36
Combi-microwave ovens 200 series	37
Microwave ovens 200 series	38
Fully automatic espresso machines 200 series	39
Warming drawers 200 series	40
Vacuuming drawers 200 series	42
Accessories special accessories 200 series	43

Checklist for appliance combinations 200 series

This checklist provides the most relevant parameters for the perfect combination and ordering of ovens, Combi-steam ovens, Combi-microwave ovens, microwaves, fully automatic espresso machines, warming drawers, vacuum drawer and dishwashers.

When several appliances are listed (BSP/BMP), the first appliance is shown.

Vertical combinations

When planning and ordering please note that

- The door hinges of the appliances must be on the same side.
- The door hinge (right-/left-hinged) is not reversible.
- No further appliances may be fitted above the BSP.
- Only appliances with controls at the top can be installed above a dishwasher. The niche for appliances that are installed above it must be 56 cm wide. The dishwasher is 60 cm wide.

Horizontal combinations

When planning and ordering please note that

- The door hinges can be located on either the inside or outside, without the full door opening angle being restricted.
- The door hinge (right-/left-hinged) cannot be reversed retrospectively.
- A minimum clearance of 10 mm between the two doors must be observed.
- Combi-steam ovens, Combi-microwave ovens, microwaves and fully automatic espresso machines in combination with a warming drawer (14 cm in height) have the same total height as a 60 cm wide ovens.

- BOP Ovens
- BSP Combi-steam ovens
- BMP Combi-microwave ovens/ microwaves
- CMP Fully automatic espresso machine
- WSP Warming drawers
- DVP Vacuum drawer
- DF Dishwashers

All appliances shown can be obtained in these appliance colours:



Gaggenau Anthracite



Gaggenau Metallic

Vertical combination, 60 cm wide appliances



- BSP 250/BMP 250
- BOP 250/BOP 220
- WSP 222



- BMP 224
- BOP 250/BOP 220
- WSP 222



- BSP 250/BMP 250
- BMP 250
- WSP 221/DVP 221



- BMP 250/BSP 250
- CMP 250
- WSP 221/DVP 221



- BMP 224
- CMP 250
- WSP 221/DVP 221



- BOP 250/BOP 220
- DF 481/DF 250



- BSP 250/BMP 250
- DF 481/DF 250



- CMP 250
- DF 481/DF 250

Horizontal combination, 60 cm wide appliances



• BOP 251/BOP 221 • BOP 250/BOP 220



• BOP 251/BOP 221 • BSP 250/BMP 250
• DVP 221/WSP 221



• BOP 251 • CMP 250
• DVP 221/WSP 221



• BSP 251/BMP 251 • BMP 250/BSP 250
• DVP 221/WSP 221 • DVP 221/WSP 221



• BMP 251/BSP 250 • CMP 250
• DVP 221/WSP 221 • DVP 221/WSP 221



• BOP 251 • CMP 250
• DVP 221/WSP 221 • BSP 250/BMP 250
• DVP 221/WSP 221



• BMP 251/BSP 250 • CMP 250
• DVP 221/WSP 221 • DVP 221/WSP 221 • BSP 250/BMP 250
• DVP 221/WSP 221

Combination of 4 with warming drawer, 60 cm wide appliances



• BOP 251/BOP 221 • BSP 250/BMP 250
• DVP 221/WSP 221 • BMP 250/BSP 250
• DVP 221/WSP 221



• BSP 251/BMP 251 • BMP 250/BSP 250
• BOP 251/BOP 221 • CMP 250
• DVP 221/WSP 221



Controls at the top

Right-hinged

BOP 250 101

Full glass door in Gaggenau Anthracite
Width 60 cm

BOP 250 111

Full glass door in Gaggenau Metallic
Width 60 cm

Left-hinged

BOP 251 101

Full glass door in Gaggenau Anthracite
Width 60 cm

BOP 251 111

Full glass door in Gaggenau Metallic
Width 60 cm

Included in the price

- 1 baking tray, enamelled
pyrolysis-safe
- 1 glass tray
- 1 wire rack
- 1 plug-in core temperature probe

Special accessories

BA 016 105

Pull-out system
Fully extendable telescopic rails and
enamelled cast iron frame.

BA 056 115

Heating element for baking stone and
Gastronorm roaster.

BA 056 133

Baking stone.
Incl. baking stone support and pizza
paddle (heating element must be
ordered separately).
Not in combination with pull-out
system.

GN 340 230

Gastronorm roaster in cast aluminium.
GN 2/3, height 165 mm, non-stick.

Oven 200 series

BOP 250/BOP 251

- Flush installation
- Pyrolytic system
- 13 heating methods, with core
temperature probe and baking
stone function
- TFT touch display
- Panel-free appliance with surface
control module
- Electronic temperature control from
30 °C to 300 °C
- 76 litres net volume
- Energy efficiency class A

Heating methods

Hot air.
Eco hot air.
Top + bottom heat.
Top heat.
Bottom heat.
Hot air + bottom heat.
Full surface grill + circulated air.
Full surface grill.
Compact grill.
Baking stone function.
Roaster function.
Dough proving.
Defrosting.

Handling

Rotary knob and TFT touch display
operation.
Clear text display in 25 languages.
Option to save 50 individual recipes
(incl. core temperature probe).
Information key with use indicators.
Side-opening door opens up to
110° angle.

Features

Core temperature probe with
automatic shut-off.
Baking stone socket.
Actual temperature display.
Rapid heating.
Timer functions: cooking time, cooking
time end, timer, stopwatch, long-term
timer.
60 W halogen light on the top.
Enamelled side shelf supports with
4 tray levels, pyrolysis-safe.

Safety

Thermally insulated door
with quintuple glazing.
Child lock.
Safety shut-off.
Cooled housing with temperature
protection.

Cleaning

Pyrolytic system.
Gaggenau enamel.
Heated air cleaning catalyser.

Planning notes

Door hinge not reversible.
The door panel surface of the
appliance extends 21 mm from the
furniture cavity.
The outer edge of the door handle
extends 72 mm from the furniture
cavity.
Necessary lateral gap between
appliance door and furniture panel
of min. 5 mm.
Consider the overhang, incl. the door
handle, when planning to open
drawers next to the appliance.

When planning a corner solution, pay
attention to the 110° door opening
angle.

For installation underneath cooktops:
Distance between the underside of the
cooktop and the top edge of the oven
cavity: min. 15 mm.

The planning notes for the cooktops
(particularly regarding ventilation, gas/
electric connection) must be taken into
account.

To achieve the 550 mm installation
depth, the connection cable needs to
follow the slanted edge on the corner
of the housing.

The mains socket needs to be planned
outside of the built-in niche.

Please read the installation details
regarding air ducting on page 8–9.

Connection

Total connected load 3.7 kW.

Power requirements

220 – 240 V / 50 Hz.

Plan a connection cable.

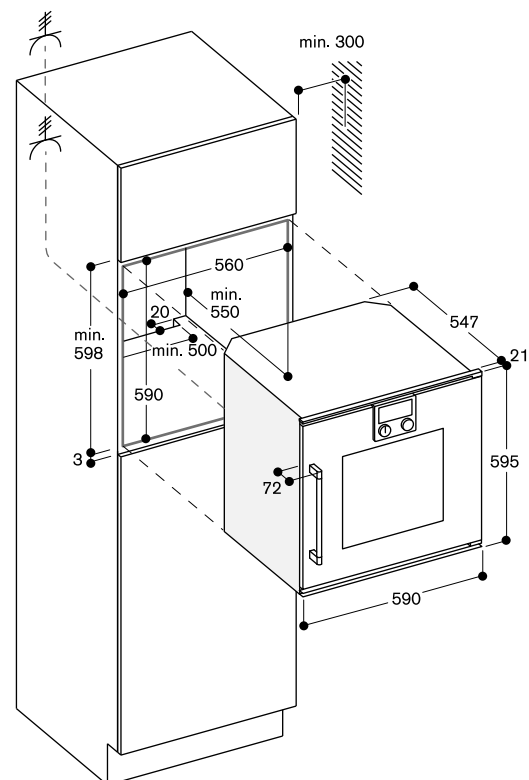
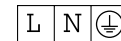



Controls at the top

Right-hinged

BOP 220 102

Full glass door in Gaggenau Anthracite

Width 60 cm

BOP 220 112

Full glass door in Gaggenau Metallic

Width 60 cm

Left-hinged

BOP 221 102

Full glass door in Gaggenau Anthracite

Width 60 cm

BOP 221 112

Full glass door in Gaggenau Metallic

Width 60 cm

Included in the price

1 baking tray, enamelled pyrolysis-safe

1 glass tray

1 wire rack

Special accessories

BA 016 105

Pull-out system

Fully extendable telescopic rails and enamelled cast iron frame.

BA 056 115

Heating element for baking stone and Gastronorm roaster.

BA 056 133

Baking stone.

Incl. baking stone support and pizza paddle (heating element must be ordered separately).

Not in combination with pull-out system.

GN 340 230

Gastronorm roaster in cast aluminium.

GN 2/3, height 165 mm, non-stick.

Oven 200 series

BOP 220/BOP 221

- Flush installation
- Pyrolytic system
- 9 heating methods, with baking stone function
- TFT touch display
- Panel-free appliance with surface control module
- Electronic temperature control from 50 °C to 300 °C
- Net volume 76 litres
- Energy efficiency class A

Heating methods

Hot air.

Eco hot air.

Top + bottom heat.

Top heat.

Bottom heat.

Hot air + bottom heat.

Full surface grill + circulated air.

Full surface grill.

Baking stone function.

Handling

Rotary knob and TFT touch display operation.

Clear text display.

Option to save 50 individual recipes.

Information key with use indicators.

Side-opening door opens up to

110° angle.

Features

Baking stone socket.

Actual temperature display.

Rapid heating.

Timer functions: cooking time, cooking time end, timer, stopwatch, long-term timer.

60 W halogen light on the top.

Enamelled side shelf supports with 4 tray levels, pyrolysis-safe.

Home network integration for digital services (Home Connect) either via cable connection LAN (recommended) or wireless via WiFi. The use of the Home Connect functionality is not yet available in Australia. For further information please check: home-connect.com

Safety

Thermally insulated door with quintuple glazing.

Child lock.

Safety shut-off.

Cooled housing with temperature protection.

Cleaning

Pyrolytic system.

Gaggenau enamel.

Heated catalyser to clean the oven air.

Planning notes

Door hinge not reversible.

The door panel surface of the appliance extends 21 mm from the furniture cavity.

The outer edge of the door handle extends 72 mm from the furniture cavity.

Necessary lateral gap between appliance door and furniture panel of min. 5 mm.

Consider the overhang, incl. the door handle, when planning to open drawers next to the appliance.

When planning a corner solution, pay attention to the 110° door opening angle.

For installation underneath cooktops: Distance between the underside of the cooktop and the top edge of the oven cavity: min. 15 mm.

The planning notes for the cooktops (particularly regarding ventilation, gas/electric connection) must be taken into account.

To achieve the 550 mm installation depth, the connection cable needs to follow the slanted edge on the corner of the housing.

The mains socket needs to be planned outside the built-in niche.

The LAN port can be found at the back on the upper right side.

Please read the installation details regarding oven combination on page 8–9.

Connection

Total connected load 3.7 kW.

Plan a connection cable.

Plan a LAN cable.

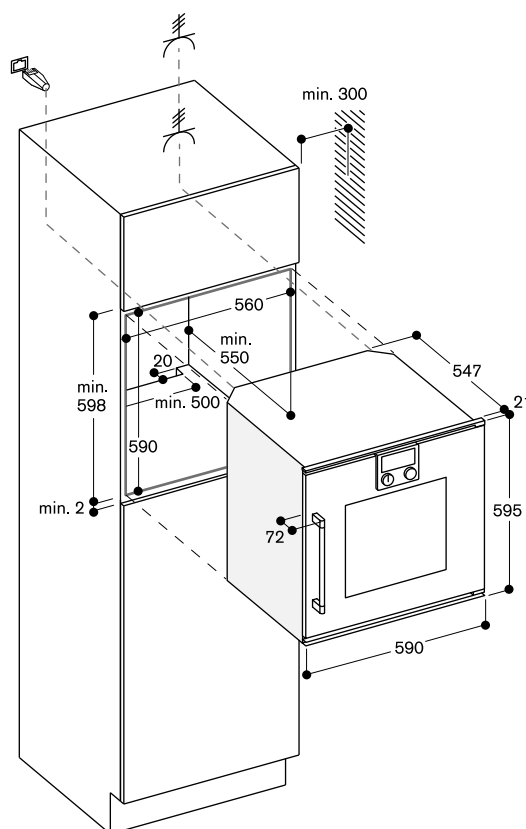
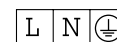



Controls at the top

Right-hinged

BSP 250 100

Full glass door in Gaggenau Anthracite

Width 60 cm

BSP 250 110

Full glass door in Gaggenau Metallic

Width 60 cm

Left-hinged

BSP 251 100

Full glass door in Gaggenau Anthracite

Width 60 cm

BSP 251 110

Full glass door in Gaggenau Metallic

Width 60 cm

Included in the price

- 1 Gastronorm insert, stainless steel, GN2/3 unperforated
- 1 Gastronorm insert, stainless steel, GN2/3 perforated
- 1 wire rack
- 1 plug-in core temperature probe

Special accessories

GN 144 230

Gastronorm insert, non-stick, GN2/3 Unperforated, 40 mm deep, 3l.

GN 154 230

Gastronorm insert, non-stick, GN2/3 Perforated, 40 mm deep, 3l.

GN 340 230

Gastronorm roaster in cast aluminium. GN2/3, height 165 mm, non-stick.

GN 410 230

Gastronorm lid, stainless steel, GN2/3.

Combi-steam oven 200 series

BSP 250/BSP 251

- Flush installation
- Water tank
- Hot air 30 °C to 230 °C can be combined with chosen humidity level of 0%, 30%, 60%, 80% or 100%
- TFT touch display
- Panel-free appliance with surface control module
- Steaming without pressure
- Electronic temperature control from 30 °C to 230 °C
- Core temperature probe, removable
- Net volume 42 litres
- Energy efficiency class A

Heating methods

Hot air + 100 % humidity.
 Hot air + 80 % humidity.
 Hot air + 60 % humidity.
 Hot air + 30 % humidity.
 Hot air + 0 % humidity.
 Dough proving.
 Defrosting.
 Regenerating.
 Low temperature cooking.

Handling

Rotary knob and TFT touch display operation.
 Clear text display in 25 languages.
 Option to save 50 individual recipes (incl. core temperature probe).
 Information key with use indicators.
 Side-opening door opens up to 110° angle.

Features

Removable 1.3litre water tank.
 Water level warning.
 Core temperature probe with automatic shut-off.
 Actual temperature display.
 Timer functions: cooking time, cooking time end, timer, stopwatch, long-term timer.
 Electronic boiling point detection.
 48 W halogen light on the side.
 Hygienic stainless steel cooking interior.
 4 tray levels.

Safety

Child lock.
 Safety shut-off.
 Cooled housing with temperature protection.

Cleaning

Cleaning aid.
 Drying program.
 Descaling program.
 Grease filter, dishwasher-safe.

Planning notes

Door hinge not reversible.
 No other electrical appliances should be installed above the BSP.
 The door panel surface of the appliance extends 21 mm from the furniture cavity.
 The outer edge of the door handle extends 72 mm from the furniture cavity.
 Necessary lateral gap between appliance door and furniture panel of min. 5 mm.
 Consider the overhang, incl. the door handle, when planning to open drawers next to the appliance.

When planning a corner solution, pay attention to the 110° door opening angle.

To achieve the 550 mm installation depth, the connection cable needs to follow the slanted edge on the corner of the housing.

The mains socket needs to be planned outside of the built-in niche.

Please read the installation details regarding air ducting on page 8–9.

Connection

Total connected load 2.0 kW.

Power requirements

220 – 240 V / 50 Hz.

Connection cable 1.5 m without plug.

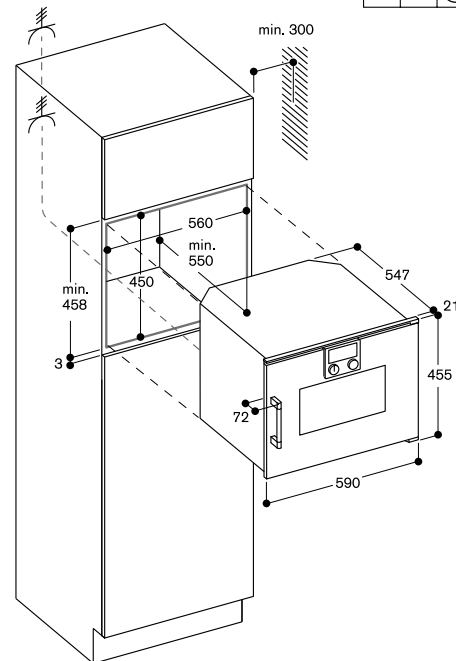
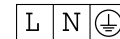

Side view of BSP, BMP over BOP

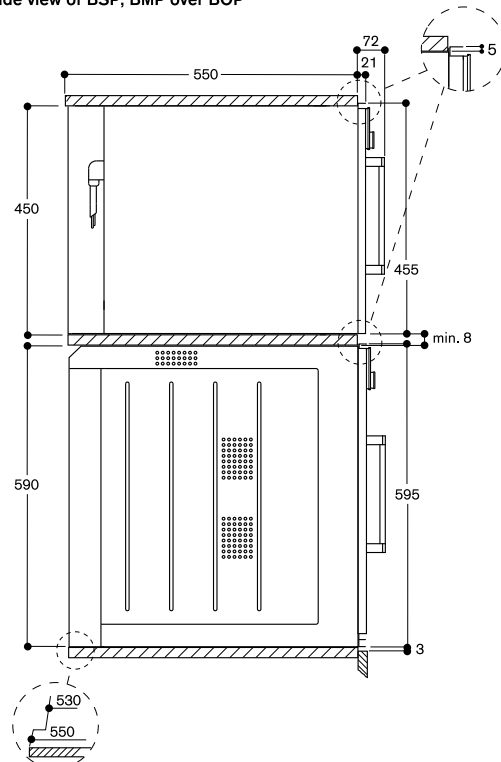



Controls at the top

Right-hinged

BMP 250 100

Full glass door in Gaggenau Anthracite
Width 60 cm

BMP 250 110

Full glass door in Gaggenau Metallic
Width 60 cm

Left-hinged

BMP 251 100

Full glass door in Gaggenau Anthracite
Width 60 cm

BMP 251 110

Full glass door in Gaggenau Metallic
Width 60 cm

Included in the price

- 1 combination wire rack
- 1 glass tub

Combi-microwave oven 200 series BMP 250/BMP 251

- Flush installation
- Single operation and combination of microwave, grill and oven
- Sequential operation of up to 5 modes incl. programming of combined operation and rest time
- TFT touch display
- Panel-free appliance with surface control module
- Electronic temperature control
- Interior volume 36 litres

Programs

Microwave operation with 5 output levels: 1000, 600, 360, 180, 90 W.
Oven operation with 4 heating methods:
Hot air 40 °C and from 100 °C to 250 °C,
Full surface grill + hot air from 100 °C to 250 °C,
Full surface grill + circulated air from 100 °C to 250 °C
Full surface grill with 3 levels of intensity, maximum output 2000 W.
Heating methods with microwave output levels 600, 360, 180 and 90 W freely combinable.
15 automatic programs with weight indication, customisable:
4 defrosting programs
4 cooking programs
7 combination programs

Handling

Rotary knob and TFT touch display operation.
Clear text display in 25 languages.
Information key with use indicators.
Side-opening door opens up to 110° angle.
Option to save individual recipes.

Features

Innowave.
Rapid heating.
4 tray levels.
Actual temperature display.
60 W halogen light on the side.

Safety

Thermally insulated door with triple glazing.
Triple door lock.
Child lock.
Safety shut-off.
Cooled housing with temperature protection.

Cleaning

Hygienic stainless steel interior with glass ceramic base.
Interior back wall with catalytic coating.

Planning notes

Door hinge not reversible.
Plan the niche without back wall.
Necessary lateral gap between appliance door and furniture panel of min. 5 mm.
The door panel surface of the appliance extends 21 mm from the furniture cavity.
The outer edge of the door handle extends 72 mm from the furniture cavity.
Consider the overhang, incl. the door handle, when planning to open drawers next to the appliance.

When planning a corner solution, pay attention to the 110° door opening angle.

The mains socket needs to be planned outside of the built-in niche.

Please read the installation details regarding air ducting on page 8–9.

Connection

Total connected load 3.1 kW.

Power requirements

220 – 240 V / 50 Hz.

Connection cable 1.5 m without plug.

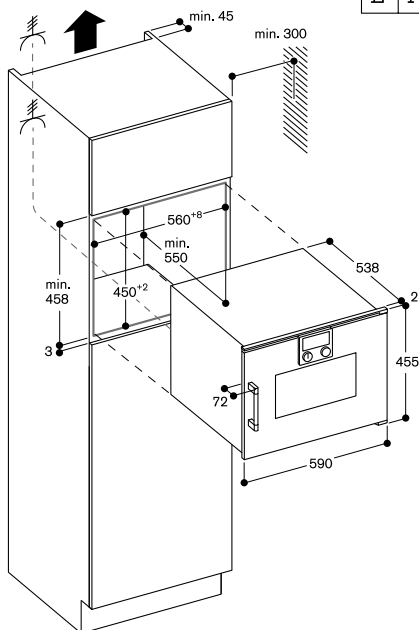
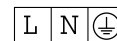

Side view of BSP, BMP over BOP

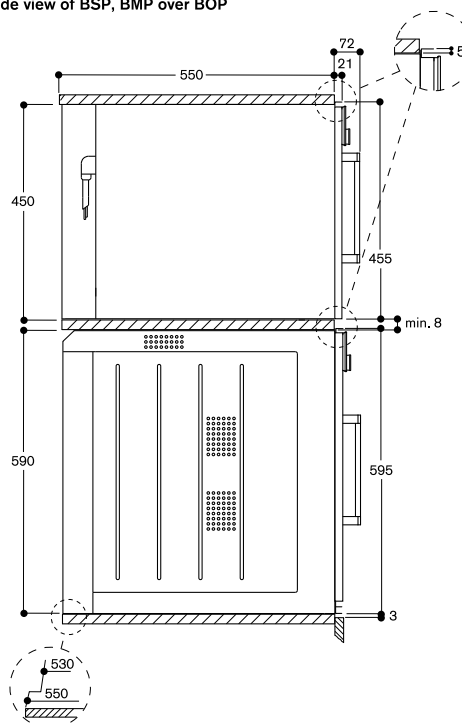



Controls at the bottom

Right-hinged

BMP 224 100

Full glass door in Gaggenau Anthracite
Width 60 cm

BMP 224 110

Full glass door in Gaggenau Metallic
Width 60 cm

Left-hinged

BMP 225 100

Full glass door in Gaggenau Anthracite
Width 60 cm

BMP 225 110

Full glass door in Gaggenau Metallic
Width 60 cm

Included in the price

1 glass tray

1 wire rack

Microwave oven 200 series

BMP 224/BMP 225

- Flush installation
- Handleless door / automatic door opening
- Single operation and combination of microwave and grill
- Sequential operation of up to 5 modes incl. programming of combined operation and rest time
- TFT touch display
- Electronic temperature control
- Interior volume 21 litres

Programs

Microwave operation with 5 output levels: 900, 600, 360, 180, 90 W.

Full surface grill with 3 levels of intensity, maximum output 1300 W.

Full surface grill with microwave output levels 360, 180 and 90 W combinable.

10 automatic programs with weight indication:

3 defrosting programs

4 cooking programs

3 combination programs

Handling

Automatic door opening.

Rotary knob and TFT touch display operation.

Clear text display in 25 languages.

Information key with use indicators.

Side-opening door opens up to 110° angle.

Option to save individual recipes.

Features

Innowave.

Actual temperature display.

25 W interior light.

Hygienic stainless steel interior with glass ceramic base.

Safety

Thermally insulated door with double glazing.

Triple door lock.

Child lock.

Safety shut-off.

Cooled housing with temperature protection.

Planning notes

Door hinge not reversible.

Minimum installation height 85 cm (top edge of niche bottom).

Height-adjustable feet.

Installation of BMP above BOP with intermediate shelf.

Necessary lateral gap between appliance door and furniture panel of min. 5 mm.

The door panel surface of the appliance extends 21 mm from the furniture cavity.

When planning a corner solution, pay attention to the 90° door opening angle.

Please read the installation details regarding air ducting on page 8-9.

Connection

Total connected load 2.0 kW.

Power requirements

220 – 240 V / 50 – 60 Hz.

Connection cable 1.7 m, with plug.

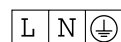

Installation in a wall-hanging cupboard

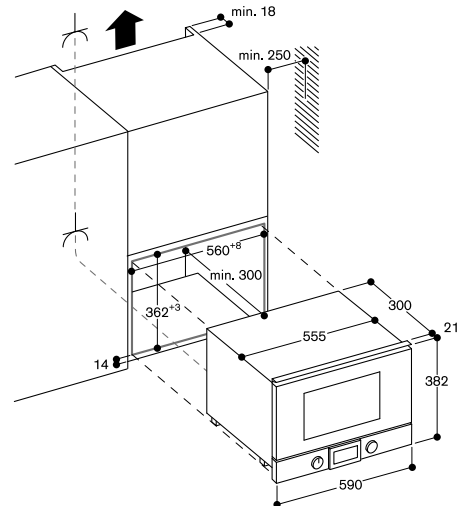

Installation in a tall cupboard

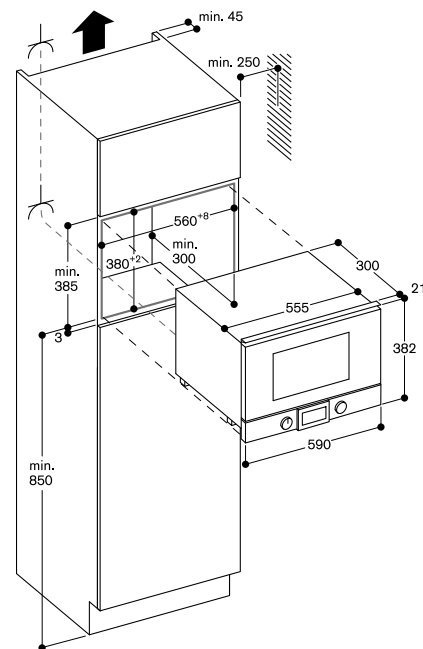

Side view of BMP 224/225 over BOP

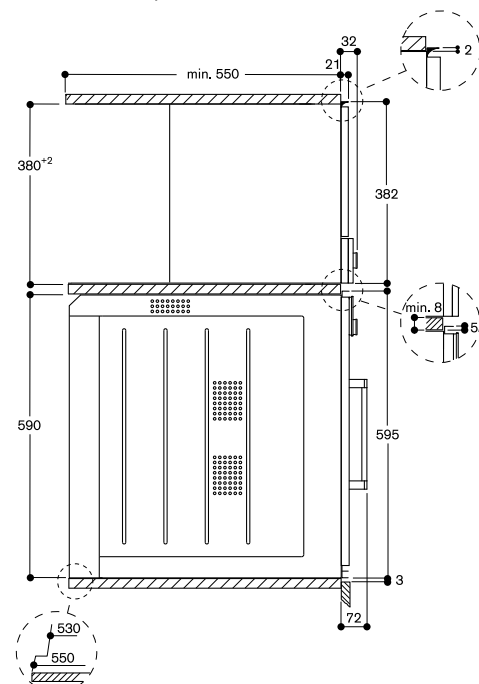



Controls at the top

Left-hinged

CMP 250 101

Full glass door in Gaggenau Anthracite
Width 60 cm

CMP 250 111

Full glass door in Gaggenau Metallic
Width 60 cm

Included in the price

- 1 assembly screws
- 1 scoop
- 1 test strip
- 1 milk container (insulated)
- 1 connection hose for milk frother
- 1 milk tube

Fully automatic espresso machine 200 series CMP 250

- Flush installation
- Handless door / cushioned door closing system
- Continuous flow heater means no waiting time and constant brewing temperature
- Aroma brewing technology for a full aroma
- Single portion cleaning
- TFT touch display
- Panel-free appliance with surface control module
- One-touch operation
- Personalisation function
- Water tank
- Seven light settings
- Electronic fill level control for milk, water and coffee to ensure a perfect result

Type of beverage

Ristretto / 2 x Ristretto.
Espresso / 2 x Espresso.
Espresso Macchiato / 2 x Espresso Macchiato.
Coffee / 2 x Coffee.
Americano / 2 x Americano.
Caffe Latte / 2 x Caffe Latte.
Latte Macchiato / 2 x Latte Macchiato.
Cappuccino / 2 x Cappuccino.
Flat White / 2 x Flat White.
Milk froth / 2 x Milk froth.
Warm milk / 2 x Warm milk.
Hot water / 2 x Hot water.

Handling

Door with cushioned door closing system.
Rotary knob and TFT touch display operation.
Clear text display in 25 languages.
Personalisation function, option to save 8 individualised beverages.
4 beverage size settings, volume can be individually adjusted to match the size of the cup.
8 coffee strength levels from very mild to extra strong.
3 coffee temperature levels.
10 hot water temperature levels.
4 coffee-milk ratio levels.
Adjustable grinding level.
Height-adjustable coffee dispenser 7 cm to 15 cm.
Easy access to water tank, milk and coffee bean container behind the door.

Features

Maintenance-free grinding unit with ceramic discs.
Separate drawer for second ground coffee type.
Water pump with 19 bar pressure.
Double grinding and brewing cycles for extra intensity for single beverage order.
For double beverage order, two grinding and brewing cycles.
Beverage dispenser with integrated milk system.
Insulated stainless steel milk container for up to 0.5 litres.
Integrated lightning with LEDs.
Removable bean container with aroma protecting lid for 500 g allows for an effortless exchange of different types of coffee beans.
Automatic adjustment of ground coffee quantity.

Removable 2.4 litre water tank.
Electronic water filter exchange indicator.
Electronic fill level control for drip tray and container for coffee residue.

Safety

Child lock.

Cleaning

Fully automatic rinse program when machine is turned on/off.
Automatic steam cleaning of the milk system after every beverage.
Automatic cleaning and descaling program.
Emptying program to prepare the appliance for holiday or transportation.
Empty-grinding function to remove coffee residues from the system when switching bean types.
Removable brewing unit.
Dishwasher-safe coffee residue container and drip tray.
Dishwasher-safe beverage dispenser.

Planning notes

Ideal installation height 95 – 145 cm (top edge of niche bottom).
Necessary lateral gap between appliance front and furniture panel of min. 5 mm.
The door panel surface of the appliance extends 21 mm from the furniture cavity.
When installing in a corner a side clearance is required.
Door opening angle appr. 110° (delivery status) - mounting distance to the wall has to be at least 350 mm.
Door opening angle appr. 155° - mounting distance to the wall has to be at least 650 mm.
Door opening angle appr. 92° - mounting distance to the wall has to be at least 100 mm (spare part No. 00636455).
Installation directly above 14 cm high warming drawer in 59 cm standardised niche.
Special accessories (order as spare parts):
Part No. 17000705 Water filter
Part No. 00311819 Descaling tablets
Part No. 00311769 Cleaning tablets
Part No. 00636455 Door hinge restrictor (92° opening angle)
Part No. 11015223 Bean container with lid

Please read the installation details regarding air ducting on page 8–9.

Connection

Total connected load 1.6 kW.
Connection cable 1.7 m with plug.

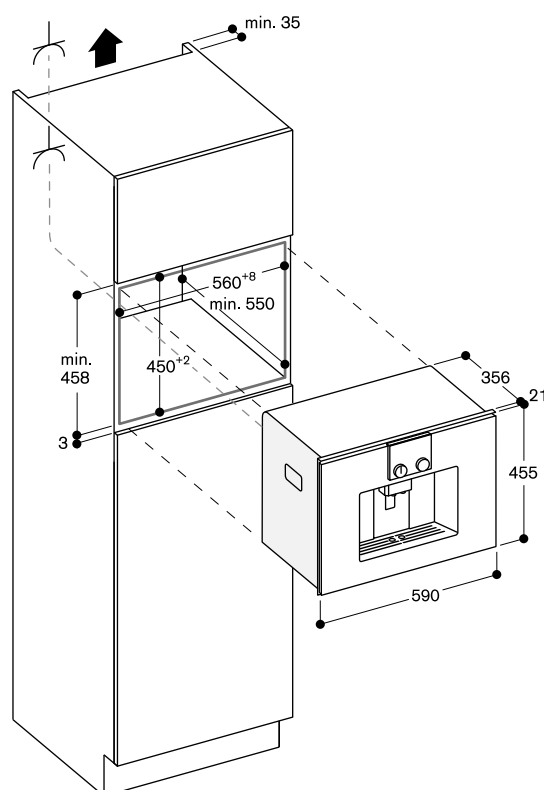



WSP 222 100

Glass front in Gaggenau Anthracite
Width 60 cm, Height 29 cm

WSP 222 110

Glass front in Gaggenau Metallic
Width 60 cm, Height 29 cm

Warming drawer 200 series

WSP 222

- Flush installation
- Handleless drawer
- Push-to-open system
- Hygienic stainless steel interior with glass bottom
- 4 power levels in the temperature range 40 °C to 80 °C (glass surface)
- Also for preparing and cooking meals, and for keeping meals warm

Heating methods

Defrosting of meals/proving of yeast dough.
Preheating of small beverage containers.
Keeping meals warm/slow cooking meals.
Warming ovenware.

Handling

Rotary knob operation.

Features

Net volume 52 litres.
Volume capacity: Dinner service for 12 people including ø 24 cm plates and soup bowls, additional bowls and a serving dish depending on size.
Max. load 25 kg.
Usable interior dimensions W 468 x H 242 x D 458 mm.
Heating under glass bottom for easy cleaning.
Fan for even heat distribution for fast warming ovenware.
Status display, visible in the glass front.
Glass bottom made of safety glass.

Planning notes

Necessary lateral gap between appliance front and furniture panel of min. 5 mm.
The door panel surface of the appliance extends 21 mm from the furniture cavity.
The socket can be planned behind the appliance.

Connection

Total connected load 0.81 kW.
Power requirements
220 – 240 V / 50 – 60 Hz.
Connection cable 1.5 m, with plug.

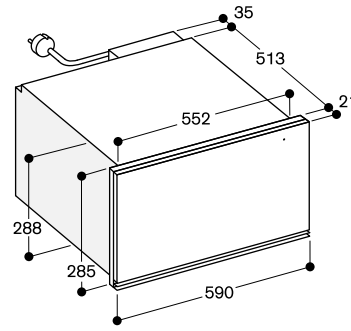

WSP 222 below BOP

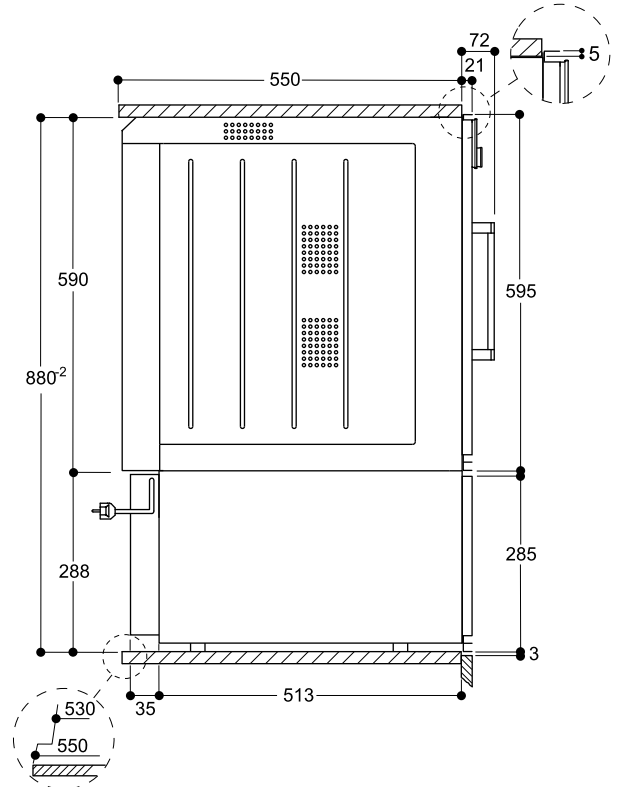

**WSP 221 100**

Glass front in Gaggenau Anthracite
Width 60 cm, Height 14 cm

WSP 221 110

Glass front in Gaggenau Metallic
Width 60 cm, Height 14 cm

Warming drawer 200 series**WSP 221**

- Flush installation
- Handleless drawer
- Push-to-open system
- Hygienic stainless steel interior with glass bottom
- 4 power levels in the temperature range 40 °C to 80 °C (glass surface)
- Also for preparing and cooking meals, and for keeping meals warm

Heating methods

Defrosting of meals/proving of yeast dough.
Preheating of small beverage containers.
Keeping meals warm/slow cooking meals.
Warming ovenware.

Handling

Rotary knob operation.

Features

Net volume 20 litres.
Volume capacity: Dinner service for 6 people including ø 24 cm plates and soup bowls, additional bowls and a serving dish depending on size.
Max. load 25 kg.
Usable interior dimensions W 468 x H 92 x D 458 mm.
Heating under glass bottom for easy cleaning.
Fan for even heat distribution for fast warming ovenware.
Status display, visible in the glass front.
Glass bottom made of safety glass.

Planning notes

Necessary lateral gap between appliance front and furniture panel of min. 5 mm.
The door panel surface of the appliance extends 21 mm from the furniture cavity.
Installation of BSP/BMP/CMP directly above WSP in 59 cm niche without intermediate floor.
The socket can be planned behind the appliance.

Connection

Total connected load 0.81 kW.
Power requirements
220 – 240 V / 50 – 60 Hz.
Connection cable 1.5 m with plug.

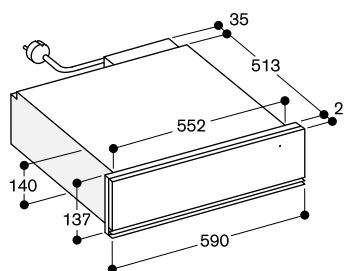
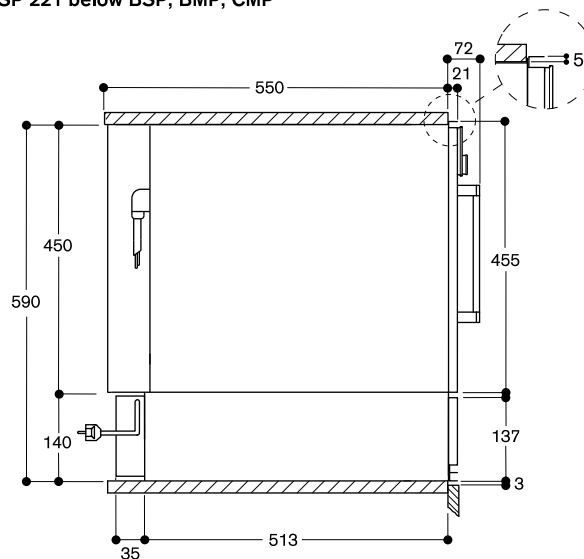
**WSP 221 below BSP, BMP, CMP**



DVP 221 100

Glass front in Gaggenau Anthracite
Width 60 cm, Height 14 cm

DVP 221 110

Glass front in Gaggenau Metallic
Width 60 cm, Height 14 cm

Included in the price

- 1 Vacuuming bag, small (50 pcs.)
- 1 Vacuuming bag, large (50 pcs.)
- 1 Raised vacuuming platform
- 1 Adaptor for vacuuming outside the chamber
- 1 Vacuuming hose
- 1 Adaptor for bottle plugs
- 3 Plugs for vacuuming of bottles

Special accessories

BA 080 670

Vacuums bags, small
180 x 280 mm, 100 pcs.

BA 080 680

Vacuums bags, large
240 x 350 mm, 100 pcs.

Vacuums drawer 200 series

DVP 221

- Flush installation
- Handleless drawer
- Push-to-open system
- Hygienic stainless steel vacuuming chamber, applicable height up to 80 mm
- Three vacuuming levels for vacuuming in the chamber, max. 99%
- Three vacuuming levels for vacuuming outside the chamber, max. 90%
- Automatic connection recognition for vacuuming outside the chamber

Application

Vacuums for sous-vide cooking.
Vacuums for fast marinating and flavouring.
Vacuums for extended storage.
Vacuums of vacuuming containers outside the chamber.
Vacuums of liquids in bottles outside the chamber.

Handling

Touch key operation.

Features

Net volume 7 litres.
Capacity load max. 10 kg.
Maximum size of vacuuming bags
W 240 mm x L 350 mm.
3 heat-sealing levels for different strengths of bag material.
Sealing bar, non-stick coating, removable.
Safety glass cover, opens automatically after vacuuming.
Raised vacuuming platform, 44 mm, deployable.
Utility space in vacuuming chamber, W 210 mm x L 275 mm.
Membrane for avoiding reflux of liquids during vacuuming outside the chamber.
Drying program for vacuuming pump.
Warning function.

Planning notes

Necessary lateral gap between appliance front and furniture panel of min. 5 mm.
The panel surface of the appliance extends 21 mm from the furniture cavity.
Installation of BS/BM/CM directly above DV in 59 cm niche without intermediate floor.
Built-in under worktop or in single niche.
The socket can be planned behind the appliance.

Please read the installation details regarding combination with ovens on the page 8–9.

Connection

Total connected load 0.32 kW.
Power requirements
220 – 240 V / 50 – 60 Hz.
Connecting cable 1.5 m with plug.

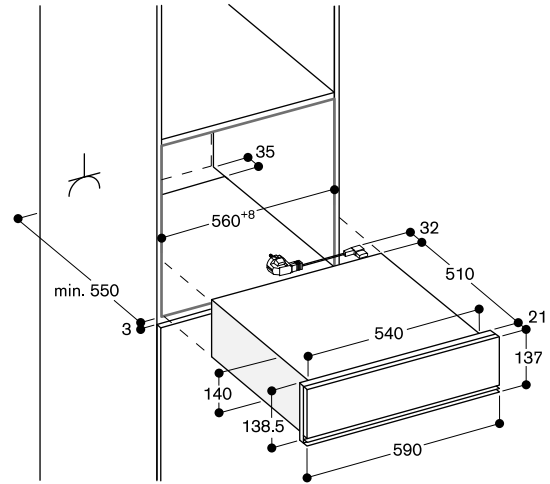

Side view of DVP 221 below BSP, BMP, CMP

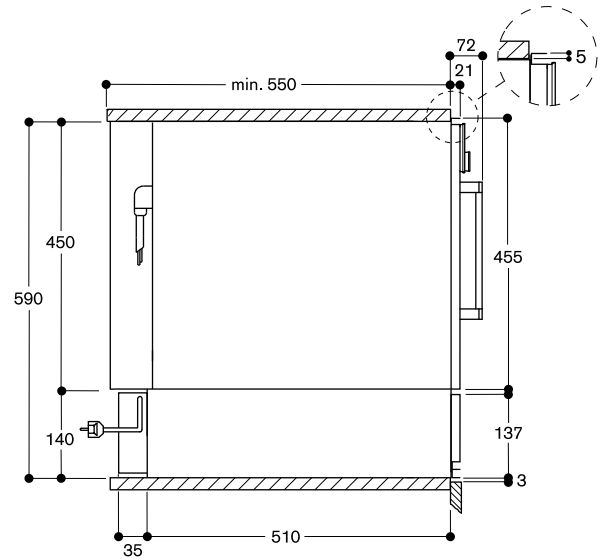

Accessories and special accessories 200 series

BA 016 105

Pull-out system
Fully extendable telescopic rails
and enamelled cast iron frame.



BA 080 670

Vacuuming bags, small
180 x 280 mm, 100 pcs.



BA 056 115

Heating element for baking stone
and Gastronorm roaster.

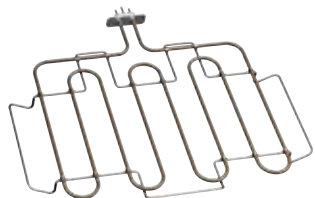

BA 080 680

Vacuuming bags, large
240 x 350 mm, 100 pcs.



BA 056 133

Baking stone
Incl. baking stone support and pizza
paddle (heating element must be
ordered separately).
Not in combination with pull-out
system.



GN 340 230

Gastronorm roaster in cast aluminium
GN 2/3, height 165 mm, non-stick
For roasting in oven with roasting
function.
Lower and upper part can also be
used separately, height 100 and
65 mm.
For ovens with pull-out system
BA 016 or BA 018 (order heating
element separately) and Combi-steam
ovens.



GN 144 230

Gastronorm insert, GN 2/3, non-stick,
Unperforated, 40 mm deep, 3 l.



GN 154 230

Gastronorm insert, GN 2/3, non-stick,
Perforated, 40 mm deep, 3 l.



GN 410 230

Gastronorm lid, stainless steel, GN 2/3
For stainless steel gastronorm inserts.



Advice:

Not every illustrated accessory fits to every oven.



The oven EB 333

EB 333	46
Accessories and special accessories EB 333	47



EB 333 110

Stainless steel
Width 90 cm

Included in the price

- 1 baking tray, enamelled pyrolysis safe
- 1 rotary spit
- 1 grill shelf
- 1 grill tub with grid
- 1 plug-in core temperature probe

Special accessories

BA 090 100

Black rotary knobs for EB 333, set of 2.

BA 018 105

Pull-out system
Fully extendable telescopic rails and enamelled cast iron frame.

BA 058 115

Heating element for baking stone and Gastronorm roaster.

BA 058 133

Baking stone.
Incl. baking stone support and pizza paddle (heating element must be ordered separately).
Not in combination with pull-out system.

GN 340 230

Gastronorm roaster in cast aluminium. GN 2/3, height 165 mm, non-stick.

Oven

EB 333

- One-piece front-hinged door with 3 mm precision crafted stainless steel front door panel
- Cushioned door opening and closing system
- Diagonally positioned light sources for optimal interior lighting
- Pyrolytic system
- 17 heating methods, with core temperature probe, rotisserie spit and baking stone function
- Hot air fan rotates in both directions for ideal heat distribution
- TFT touch display
- Panel-free appliance with control module behind glass
- Electronic temperature control from 30°C to 300°C
- 83 litres net volume

Heating methods

Hot air.
Eco hot air.
Top + bottom heat.
Top + 1/3 bottom heat.
Top heat.
1/3 top + bottom heat.
Bottom heat.
Hot air + bottom heat.
Hot air + 1/3 bottom heat.
Full surface grill + circulated air.
Full surface grill.
Compact grill.
Baking stone function.
Roaster function.
Dough proving.
Defrosting.
Keeping warm.

Handling

Rotary knob and TFT touch display operation.
Clear text display in 25 languages.
Option to save 50 individual recipes (incl. core temperature probe).
Information key with use indicators.
Front-hinged door with 90° door opening angle.

Features

Core temperature probe with automatic shut-off.
Rotisserie spit.
Baking stone socket.
Actual temperature display.
Rapid heating.
Timer functions: cooking time, cooking time end, timer, stopwatch, long-term timer.
60 W halogen light on the top.
2 x 10 W halogen light on the side.
Enamelled side shelf supports with 3 tray levels, pyrolysis-safe.

Safety

Thermally insulated door with quintuple glazing.
Child lock.
Safety shut-off.
Cooled housing with temperature protection.

Cleaning

Pyrolytic system.
Gaggenau enamel.
Heated air cleaning catalyser.

Planning notes

The door panel surface of the appliance extends 40 mm from the furniture cavity.
The outer edge of the door handle extends 90 mm from the furniture cavity.
For installation underneath cooktops: Distance between the underside of the cooktop and the top edge of the oven cavity: min. 15mm.
The planning notes for the cooktops (particularly regarding ventilation, gas/electric connection) must be taken into account.
To achieve the 550 mm installation depth, the connection cable needs to follow the slanted edge on the corner of the housing.
The mains socket needs to be planned outside the built-in niche.

Connection

Total connected load 5.4 kW.
Power requirements
220 – 240 V / 50 Hz.
Plan a connection cable.

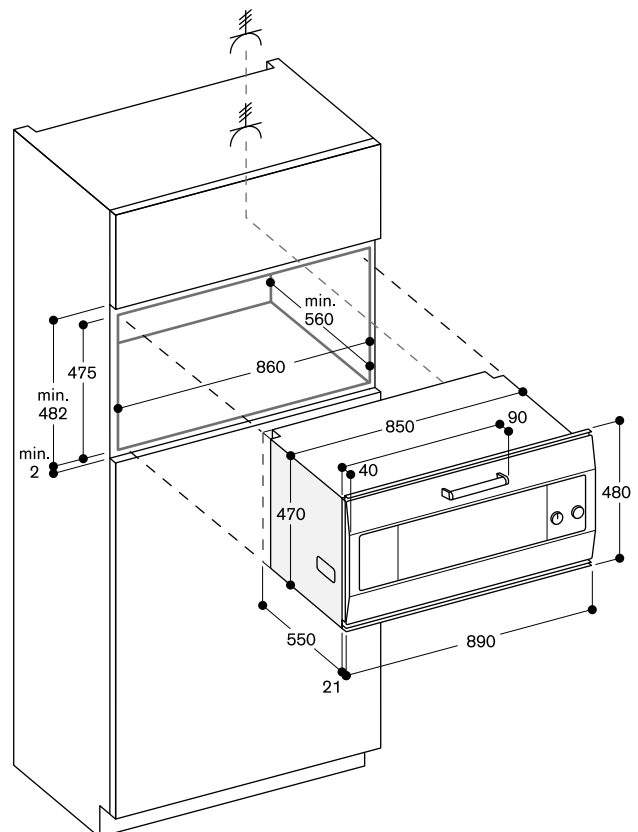
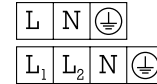

Accessories and special accessories EB 333

BA 090 100

Stainless steel knobs with black coating.



BA 018 105

Pull-out system
Fully extendable telescopic rails and enamelled cast iron frame.



BA 058 115

Heating element for baking stone and Gastronorm roaster

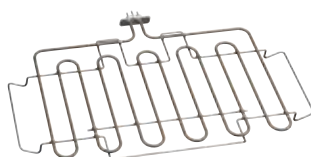

BA 058 133

Baking stone
Incl. baking stone support and pizza paddle (heating element must be ordered separately). Not in combination with pull-out system.



GN 340 230

Gastronorm roaster in cast aluminium GN 2/3, height 165 mm, non-stick
For roasting in oven with roasting function.

Lower and upper part can also be used separately, height 100 and 65 mm.

For ovens with pull-out system BA 016 or BA 018 (order heating element separately) and Combi-steam ovens.







The Vario cooktops

Vario cooktops 400 series	50
Vario downdraft ventilation 400 series	66
Table ventilation 400 series	70
Cut-out dimensions for appliance combinations in the 400 series	72
Installation with appliance cover and filler strip in the 400 series	77
Vario cooktops 200 series	78
Vario downdraft ventilation 200 series	85
Cut-out dimensions for appliance combinations in the 200 series	86
Accessories special accessories	88



CX 482 110

Stainless steel frame
Width 80 cm

Included in the price

1 Cooking sensor for temperature regulation

Installation accessories

VA 420 000

Connection strip for combination with other Vario appliances of the 400 series for flush mounting

VA 420 001

Connection strip for combination with other Vario appliances of the 400 series for flush mounting with appliance cover/filler strip

VA 420 010

Connection strip for combination with other Vario appliances of the 400 series for surface mounting

VA 420 011

Connection strip for combination with other Vario appliances of the 400 series for surface mounting with appliance cover/filler strip

VA 450 800

Stainless steel filler strip 80 cm
Necessary accessory for combination of several Vario appliances of the 400 series with at least one appliance cover to compensate the appliance depth.

Special accessories

CA 060 300

Cooking sensor for temperature regulation within pots
For flex induction cooktop.

GN 232 110

Teppan Yaki plate made of multi ply material,
GN 1/1
For full surface induction cooktops.

Full surface induction cooktop 400 series

CX 482

- One single large cooking surface
- Free positioning of cookware
- All sizes and formats of cookware can be used
- TFT touch display for an intuitive control of all functions
- Cooking sensor function for temperature control in pots
- Professional cooking functions
- Max. power output for big cookware of up to 5.5 kW
- Precision crafted 3 mm stainless steel
- For surface mounting with a visible edge or for flush mounting
- Can be combined perfectly with other Vario appliances of the 400 series

Cooking zones

One unique cooking surface of 2750 cm².

Up to 5 items of cookware can be placed simultaneously on the cooktop.

Handling

Easy to use colour graphic TFT touch display with use indications.

Electronic power control in 17 output levels.

Features

Cooking sensor function.

Professional cooking function.

Dynamic cooking function.

Teppan Yaki function.

Booster function for pots.

Booster function for pans.

Keep warm function.

Individual pot detection.

Cooking timer for each cooking position.

Stopwatch.

Short-term timer.

Information key with use indicators.

Power management.

Home network integration for digital services (Home Connect) either via cable connection LAN (recommended) or wireless via WiFi. The use of the Home Connect functionality is not yet available in Australia. For further information please check:
home-connect.com

Safety

Main switch.

Residual heat indication.

Child lock.

Safety shut-off.

Pause function.

Planning notes

Depending on the type of installation (surface-mounted or flush-mounted), the specific definition of the cut-out must be observed.

If combining several appliances with at least one appliance cover, the filler strip VA 450 is required to compensate for the depth of the appliance without the appliance cover.

If combining several Vario appliances of the 400 series, a connection strip VA 420 must be placed between the appliances. Depending on the type of installation, the corresponding connection strip must be provided. In the cut-out, the installation system requires the side edge to be at least 10 mm for surface mounting and at least 13 mm for flush mounting. Ensure a continuous cut surface of 90°.

The bearing capacity and stability, in the case of thin worktops in particular, must be supported using suitable substructures. Take into account the appliance weight and additional loads. Additional instructions for flush mounting:

Installation is possible in worktops made of stone, synthetics or solid wood. Heat resistance and watertight sealing of the cut edges must be observed. Concerning other materials please consult the worktop manufacturer. The groove must be continuous and even, so that uniform placing of the appliance on the gasket is ensured. Do not use discontinuous lining. The joint width may vary due to size tolerances of the combinations and of the worktop cut-out.

Please read additional planning notes on page 72–77.

If installing several appliances in individual cut-outs allow for a division bar of minimum 50 mm between the individual cut-outs. Operates with magnetic (induction) iron pots and pans only. For an optimal heat distribution, the use of sandwich bottom cookware is recommended. The wok pan WP 400 001 cannot be used with this appliance. Intermediate shelf is recommended. Appliance can be snapped into the worktop from above. Appliance weight: approx. 27 kg.

Please read the installation details regarding air ducting on page 100.

Connection

Total connected load 7.4 kW.

Connecting cable 1.5 m without plug.

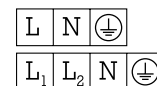

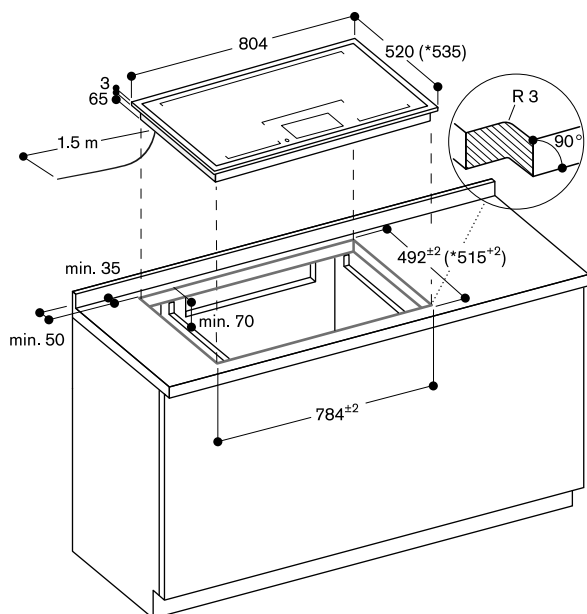

* with filler strip
See separate planning notes.

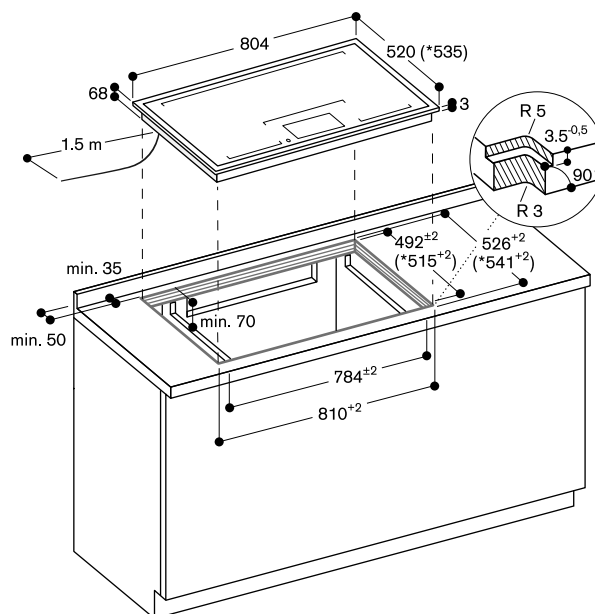

* with filler strip
See separate planning notes.

View from above

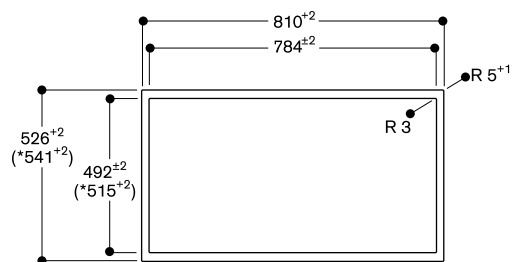

* with filler strip.

Longitudinal section

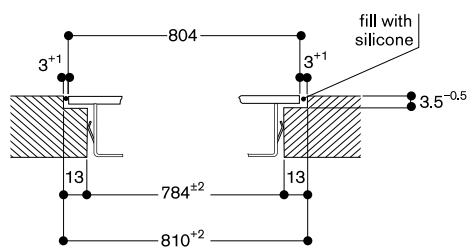

Cross-section

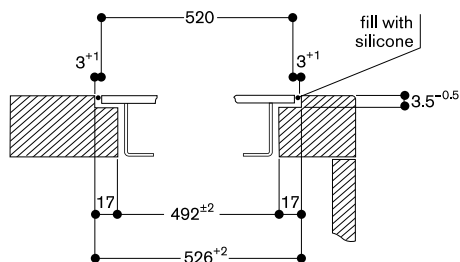

When installing with appliance cover or filler strip, pay attention to the deeper cut-out and the front and rear groove width.



VI 462 111

Stainless steel frame
Width 60 cm

Installation accessories

VA 420 000

Connection strip for combination with other Vario appliances of the 400 series for flush mounting

VA 420 001

Connection strip for combination with other Vario appliances of the 400 series for flush mounting with appliance cover/filler strip

VA 420 010

Connection strip for combination with other Vario appliances of the 400 series for surface mounting

VA 420 011

Connection strip for combination with other Vario appliances of the 400 series for surface mounting with appliance cover/filler strip

VA 450 600

Stainless steel filler strip 60 cm
Necessary accessory for combination of several Vario appliances of the 400 series with at least one appliance cover to compensate the appliance depth.

Special accessories

GP 900 003

Stainless steel frying sensor pan

GP 900 004

Stainless steel frying sensor pan

Vario flex induction cooktop 400 series

VI 462

- Flex function for combining the rectangular cooking areas
- Free positioning of cookware inside combined cooking areas with automatic extension up to 30 cm width
- Frying sensor function for temperature control in pans
- Easy control of all functions with bicoloured display
- Solid stainless steel control knob
- Precision crafting of 3 mm stainless steel
- For surface mounting with a visible edge or for flush mounting
- Can be combined perfectly with other Vario appliances of the 400 series

Cooking zones

2 flex induction cooking areas with each 19x23 cm (2200 W, with booster 3700 W), linked together 38x23 cm (3300 W, with booster 3700 W), with automatic extension up to 30x30 cm (3300 W, with booster 3700 W).
2 flex induction cooking areas 19x23 cm (2200 W, with booster 3700 W), linked together 38x23 cm (3300 W, with booster 3700 W).

Handling

4 flexible installation control knobs (1.4 m connecting cable)
Control knobs with illuminated ring, cooking zone and output level markings.
Electronic power control in 12 output levels.
User friendly control with bicoloured display (white / orange).

Features

Flex function for rectangular cooking areas.
Frying sensor function.
Booster function.
Stopwatch.
Short-term timer.
Options menu.

Safety

Individual residual heat indicators.
Safety shut-off.

Planning notes

Depending on the type of installation (surface-mounted or flush-mounted, with or without an appliance cover), the specific location of the cut-out and the knob positions may vary.
The horizontal positioning of the knobs may be aligned with the specific cooking areas.
The drawing "Installation of the control knob" must be observed if the panel is more than 26 mm thick (there must be a recess at the rear).
If installing with the appliance cover VA 440 or filler strip VA 450 take into account the additional space required for the depth.
If combining several appliances with at least one appliance cover, the filler strip VA 450 is required to compensate for the depth of the appliance without the appliance cover.

If combining several Vario appliances of the 400 series, a connection strip VA 420 must be placed between the appliances. Depending on the type of installation, the corresponding connection strip must be provided. In the cut-out, the installation system requires the side edge to be at least 10 mm for surface mounting and at least 13 mm for flush mounting. Ensure a continuous cut surface of 90°. The bearing capacity and stability, in the case of thin worktops in particular, must be supported using suitable substructures. Take into account the appliance weight and additional loads. Additional instructions for flush mounting:

Installation is possible in worktops made of stone, synthetics or solid wood. Heat resistance and watertight sealing of the cut edges must be observed. Concerning other materials please consult the worktop manufacturer.

The groove must be continuous and even, so that uniform placing of the appliance on the gasket is ensured. Do not use discontinuous lining. The joint width may vary due to size tolerances of the combinations and of the worktop cut-out.

Please read additional planning notes on page 72–77.

If installing several appliances in individual cut-outs allow for a division bar of minimum 50 mm between the individual cut-outs. Operates with magnetic (induction) iron pots and pans only. For an optimal heat distribution, the use of sandwich bottom cookware is recommended. The wok pan WP 400 001 cannot be used with this appliance. Appliance can be snapped into the worktop from above.

Appliance weight: approx. 18 kg.

Please read the installation details regarding air ducting on page 100.

Connection

Total connected load 7.4 kW.
Connecting cable 1.5 m without plug.

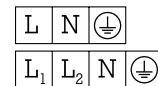

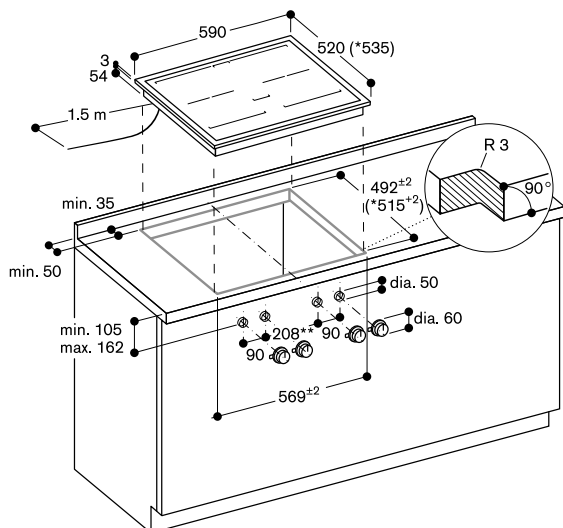

* with filler strip.
See separate planning notes.
** max. 300

Installation of the control knob; surface mounting

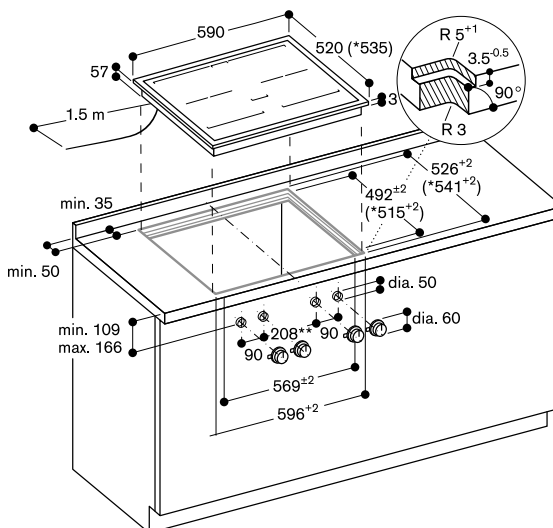
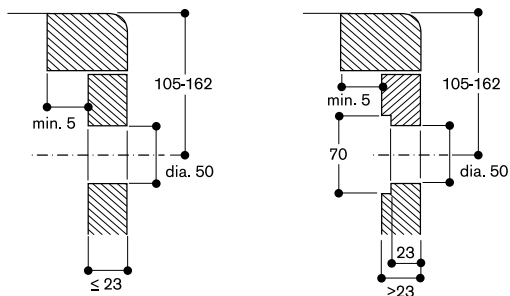

* with filler strip.
See separate planning notes.
** max. 300

Installation of the control knob; flush installation

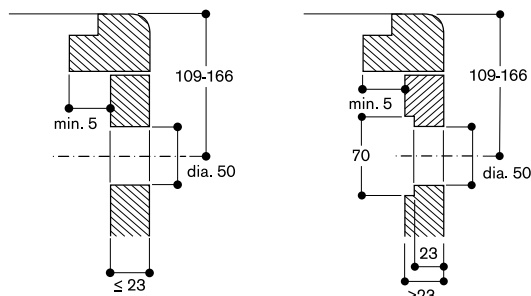

View from above

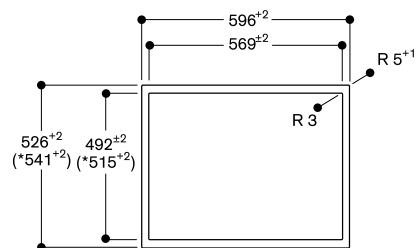

* with filler strip

Longitudinal section

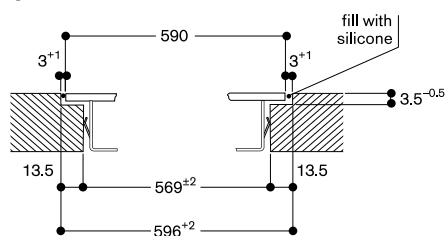

Cross-section

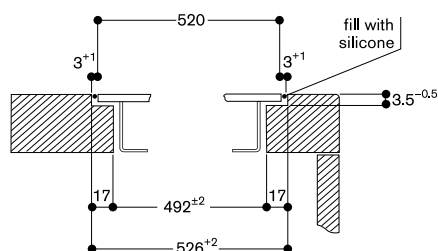

When installing with appliance cover or filler strip, pay attention to the deeper cut-out and the front and rear groove width.



VI 414 111

Stainless steel frame
Width 38 cm

Installation accessories

VA 420 000

Connection strip for combination with other Vario appliances of the 400 series for flush mounting

VA 420 001

Connection strip for combination with other Vario appliances of the 400 series for flush mounting with appliance cover/filler strip

VA 420 010

Connection strip for combination with other Vario appliances of the 400 series for surface mounting

VA 420 011

Connection strip for combination with other Vario appliances of the 400 series for surface mounting with appliance cover/filler strip

VA 450 401

Stainless steel filler strip 38 cm
Necessary accessory for combination of several Vario appliances of the 400 series with at least one appliance cover to compensate the appliance depth.

Special accessories

GP 900 004

Stainless steel frying sensor pan

WP 400 001

Wok pan made of multiple-layer material

WZ 400 001

Wok attachment for wok pan
Only for Vario induction wok.

Vario induction wok 400 series

VI 414

- 32 cm cooking zone with booster function
- Ideal for the original wok pan with round bottom, with wok ring
- Frying sensor function for temperature control in pans
- Easy control of all functions with bicoloured display
- Solid stainless steel control knob
- Precision crafting of 3 mm stainless steel
- For surface mounting with a visible edge or for flush mounting
- Can be combined perfectly with other Vario appliances of the 400 series

Cooking zones

1 induction cooking zone \varnothing 21 cm (2200 W, with booster 3700 W), automatically switches to \varnothing 26 cm (2600 W, with booster 3700 W) and to \varnothing 32 cm (3300 W, with booster 3700 W).

Handling

1 flexible installation control knob (1.4 m connecting cable)
Control knob with illuminated ring, cooking zone and output level markings.
Electronic power control in 12 output levels.
User friendly control with bicoloured display (white / orange).

Features

Frying sensor function.
Booster function.
Stopwatch.
Short-term timer.
Options menu.

Safety

Residual heat indication.
Safety shut-off.

Planning notes

Depending on the type of installation (surface-mounted or flush-mounted, with or without an appliance cover), the specific location of the cut-out and the knob positions may vary.
The drawing "Installation of the control knob" must be observed if the panel is more than 26 mm thick (there must be a recess at the rear).
If installing with the filler strip VA 450 take into account the additional space required for the depth.
If combining several appliances with at least one appliance cover, the filler strip VA 450 is required to compensate for the depth of the appliance without the appliance cover.
If combining several Vario appliances of the 400 series, a connection strip VA 420 must be placed between the appliances. Depending on the type of installation, the corresponding connection strip must be provided. In the cut-out, the installation system requires the side edge to be at least 10 mm for surface mounting and at least 13 mm for flush mounting. Ensure a continuous cut surface of 90°.
The bearing capacity and stability, in the case of thin worktops in particular, must be supported using suitable substructures. Take into account the appliance weight and additional loads.

Additional instructions for flush mounting:
Installation is possible in worktops made of stone, synthetics or solid wood. Heat resistance and watertight sealing of the cut edges must be observed. Concerning other materials please consult the worktop manufacturer.
The groove must be continuous and even, so that uniform placing of the appliance on the gasket is ensured. Do not use discontinuous lining. The joint width may vary due to size tolerances of the combinations and of the worktop cut-out.

Please read additional planning notes on page 72–77.

If installing several appliances in individual cut-outs allow for a division bar of minimum 50 mm between the individual cut-outs.
Operates with magnetic (induction) iron pots and pans only. For an optimal heat distribution, the use of sandwich bottom cookware is recommended. Appliance can be snapped into the worktop from above.
Appliance weight: approx. 10 kg.

Please read the installation details regarding air ducting on page 100.

Connection

Total connected load 3.7 kW.
Connecting cable 1.5 m without plug.

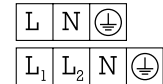

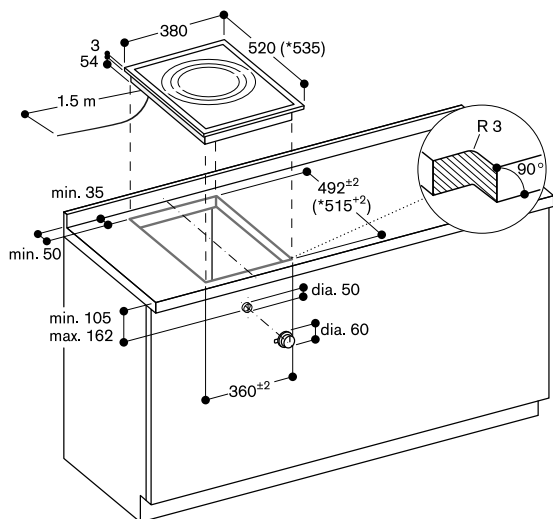

* with appliance cover or filler strip.
See separate planning notes.

Installation of the control knob; surface mounting

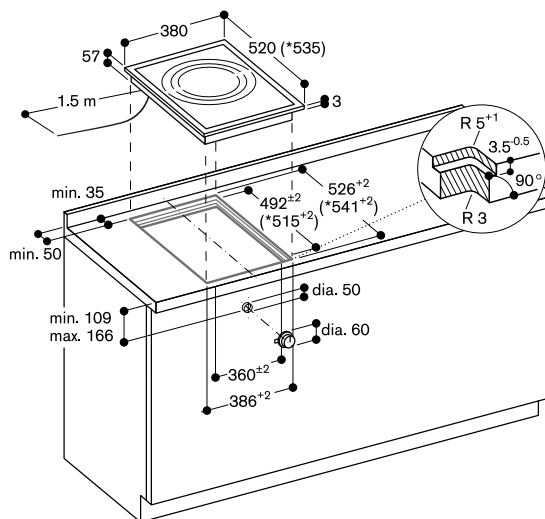
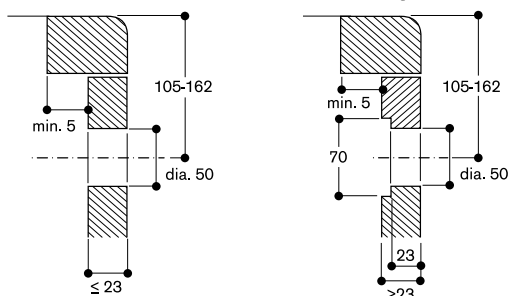

* with appliance cover or filler strip.
See separate planning notes.

Installation of the control knob; flush installation

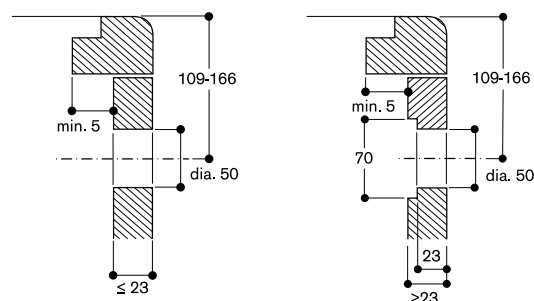

View from above

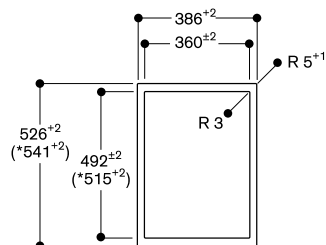

* with appliance cover or filler strip
(observe the front and rear asymmetrical support,
see separate notes "Installation with appliance
cover/filler strip").

Longitudinal section

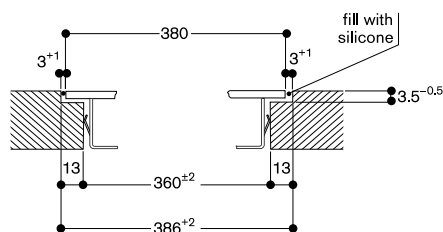

Cross-section

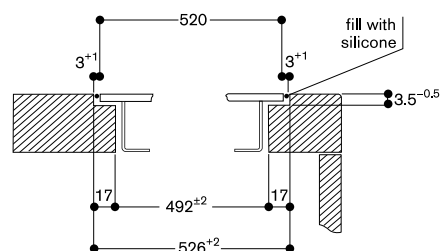

When installing with appliance cover or filler strip, pay attention
to the deeper cut-out and the front and rear groove width.



VI 422 111

Stainless steel frame
Width 38 cm

Installation accessories

VA 420 000

Connection strip for combination with other Vario appliances of the 400 series for flush mounting

VA 420 001

Connection strip for combination with other Vario appliances of the 400 series for flush mounting with appliance cover/filler strip

VA 420 010

Connection strip for combination with other Vario appliances of the 400 series for surface mounting

VA 420 011

Connection strip for combination with other Vario appliances of the 400 series for surface mounting with appliance cover/filler strip

VA 450 401

Stainless steel filler strip 38 cm
Necessary accessory for combination of several Vario appliances of the 400 series with at least one appliance cover to compensate the appliance depth.

Special accessories

GP 900 003

Stainless steel frying sensor pan

Vario flex induction cooktop 400 series

VI 422

- Flex function for combining the rectangular cooking areas
- Free positioning of cookware inside combined cooking areas
- Frying sensor function for temperature control in pans
- Easy control of all functions with bicoloured display
- Solid stainless steel control knob
- Precision crafting of 3 mm stainless steel
- For surface mounting with a visible edge or for flush mounting
- Can be combined perfectly with other Vario appliances of the 400 series

Cooking zones

2 flex induction cooking areas
19x23 cm (2200 W, with booster 3700 W), linked together 38x23 cm (3300 W, with booster 3700 W).

Handling

2 flexible installation control knobs (1.4 m connecting cable)
Control knobs with illuminated ring, cooking zone and output level markings.
Electronic power control in 12 output levels.
User friendly control with bicoloured display (white / orange).

Features

Flex function for rectangular cooking areas.
Frying sensor function.
Booster function.
Stopwatch.
Short-term timer.
Options menu.

Safety

Individual residual heat indicators.
Safety shut-off.

Planning notes

Depending on the type of installation (surface-mounted or flush-mounted, with or without an appliance cover), the specific location of the cut-out and the knob positions may vary.

The horizontal positioning of the knobs may be aligned with the specific cooking areas.

The drawing "Installation of the control knob" must be observed if the panel is more than 26 mm thick (there must be a recess at the rear).

If installing with the or filler strip VA 450 take into account the additional space required for the depth.

If combining several appliances with at least one appliance cover, the filler strip VA 450 is required to compensate for the depth of the appliance without the appliance cover.

If combining several Vario appliances of the 400 series, a connection strip VA 420 must be placed between the appliances. Depending on the type of installation, the corresponding connection strip must be provided.

In the cut-out, the installation system requires the side edge to be at least 10 mm for surface mounting and at least 13 mm for flush mounting. Ensure a continuous cut surface of 90°.

The bearing capacity and stability, in the case of thin worktops in particular, must be supported using suitable substructures. Take into account the appliance weight and additional loads. Additional instructions for flush mounting:

Installation is possible in worktops made of stone, synthetics or solid wood. Heat resistance and watertight sealing of the cut edges must be observed. Concerning other materials please consult the worktop manufacturer.

The groove must be continuous and even, so that uniform placing of the appliance on the gasket is ensured. Do not use discontinuous lining. The joint width may vary due to size tolerances of the combinations and of the worktop cut-out.

Please read additional planning notes on page 72-77.

If installing several appliances in individual cut-outs allow for a division bar of minimum 50 mm between the individual cut-outs.

Operates with magnetic (induction) iron pots and pans only. For an optimal heat distribution, the use of sandwich bottom cookware is recommended. Appliance can be snapped into the worktop from above.
Appliance weight: approx. 10 kg.

Please read the installation details regarding air ducting on page 100.

Connection

Total connected load 3.7 kW.
Connecting cable 1.5 m without plug.

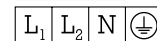
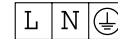

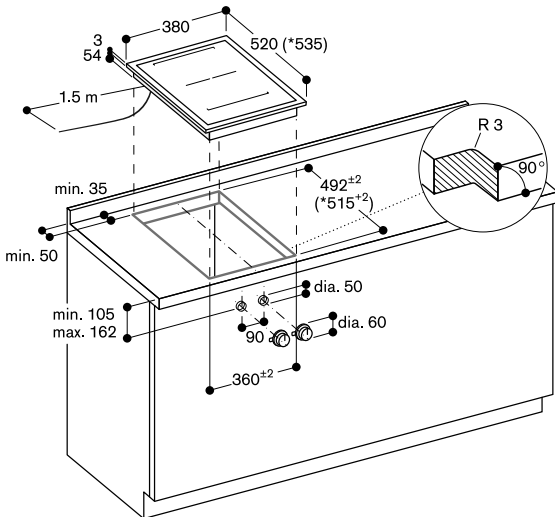

* with appliance cover or filler strip.
See separate planning notes.

Installation of the control knob; surface mounting

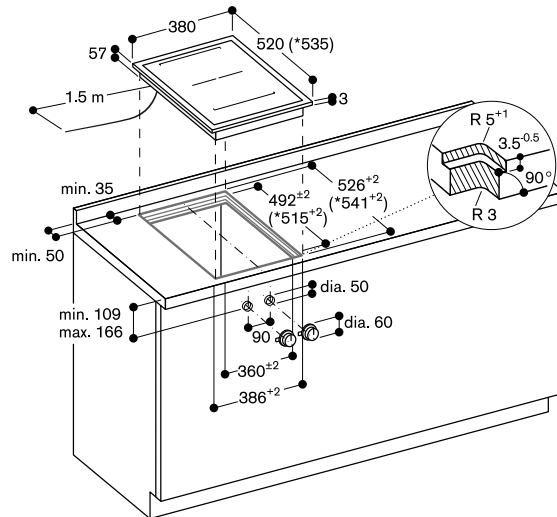
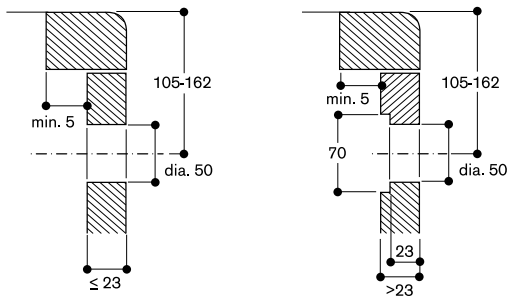

* with appliance cover or filler strip
See separate planning notes.

Installation of the control knob; flush installation

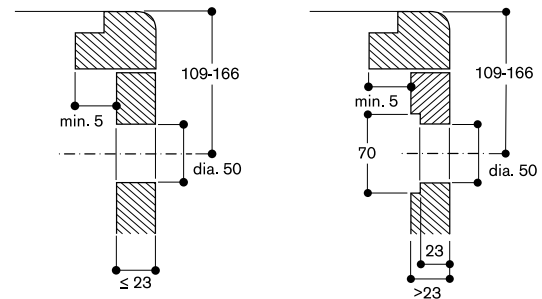

View from above

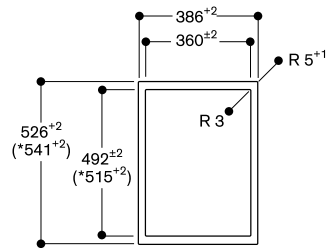

* with appliance cover or filler strip
(observe the front and rear asymmetrical support,
see separate notes "Installation with appliance
cover/filler strip").

Longitudinal section

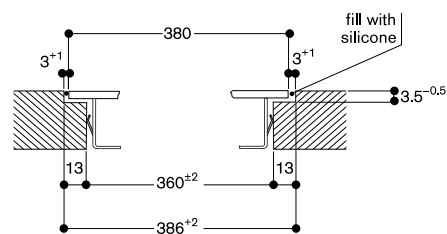

Cross-section

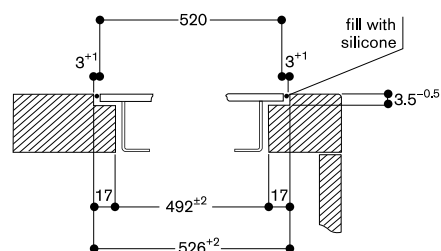

When installing with appliance cover or filler strip, pay attention
to the deeper cut-out and the front and rear groove width.



VG 415 211 AU

Stainless steel
Width 38 cm
Natural gas 18 MJ/h
Wok burner with 6 kW

Installation accessories

VA 420 010

Connection strip for combination with other Vario appliances of the 400 series for surface mounting

VA 420 011

Connection strip for combination with other Vario appliances of the 400 series for surface mounting with appliance cover/filler strip

VA 420 000

Connection strip for combination with other Vario appliances of the 400 series for flush mounting

VA 420 001

Connection strip for combination with other Vario appliances of the 400 series for flush mounting with appliance cover/filler strip

VA 440 010

Stainless steel appliance cover with mounting strip

VA 450 400

Stainless steel filler strip 38 cm
Necessary accessory for combination of several Vario appliances of the 400 series with at least one appliance cover to compensate the appliance depth.

Special accessories

WP 400 001

Wok pan made of multiple-layer material
With round bottom and handle, ø 36 cm, 6 litres, height 10 cm.

Vario gas wok 400 series

VG 415

- 18 MJ/h multi-ring burner
- Full electronic power level regulation on 12 levels
- Precise and reproducible flame size
- Automatic fast ignition, electronic flame monitoring with automatic reignition
- Simmer function for cooking on a very low output level
- Solid stainless steel control knob
- Precision crafting of 3 mm stainless steel
- For surface mounting with a visible edge or for flush mounting
- Can be combined perfectly with other Vario appliances of the 400 series

Cooking zones

1 multi-ring wok burner
18 MJ/h, suitable for pots up to max. ø 32 cm.

Handling

1 flexible installation control knob (1.4 m connecting cable)
Control knob with illuminated ring, cooking zone and output level markings.
One-handed operation.
Full electronic control in 12 output levels for exact power level regulation plus simmer function.
Automatic fast ignition.

Features

Simmer function.
Cast pan support with flat, continuous pot surface.
Brass burner rings.

Safety

Electronic flame monitoring with automatic re-ignition.
Residual heat indication.
Safety shut-off.

Planning notes

Depending on the type of installation (surface-mounted or flush-mounted, with or without an appliance cover), the specific location of the cut-out and the knob positions may vary.

The drawing "Installation of the control knob" must be observed if the panel is more than 23 mm thick (there must be a recess at the rear).

If installing with the appliance cover VA 440 or filler strip VA 450 take into account the additional space required for the depth.

If combining several appliances with at least one appliance cover, the filler strip VA 450 is required to compensate for the depth of the appliance without the appliance cover.

If combining several Vario appliances of the 400 series, a connection strip VA 420 must be placed between the appliances. Depending on the type of installation, the corresponding connection strip must be provided. In the cut-out, the installation system requires the side edge to be at least 10 mm for surface mounting and at least 13 mm for flush mounting. Ensure a continuous cut surface of 90°.

The bearing capacity and stability, in the case of thin worktops in particular,

must be supported using suitable substructures. Take into account the appliance weight and additional loads. Additional instructions for flush mounting:

Installation is possible in worktops made of stone, synthetics or solid wood. Heat resistance and watertight sealing of the cut edges must be observed. Concerning other materials please consult the worktop manufacturer.

The groove must be continuous and even, so that uniform placing of the appliance on the gasket is ensured. Do not use discontinuous lining. The joint width may vary due to size tolerances of the combinations and of the worktop cut-out.

Please read additional planning notes on page 72–77.

If installing several appliances in individual cut-outs allow for a division bar of minimum 50 mm between the individual cut-outs.

Special nozzles can be ordered as spare parts.

Plan for an electrical connection (the appliance is not operable without power supply).

Air intake from above.

No intermediate shelf required.

Rear panel and wall trims must be heat-resistant and consist of a nonflammable material.

A minimum clearance of at least 150 mm from adjacent heat-sensitive furniture or contact surfaces must be observed or thermal insulation fitted.

If operated next to the downdraft ventilation VL 414, the air baffle AA 414 is recommended to ensure maximum performance of the cooktop.

With a total connected load of more than 39.6 MJ/h local regulations concerning room ventilation, room size and combination of extraction or recirculation hoods must be observed.

Minimum clearance between gas cooktop(s) with more than 39.6 MJ/h and ventilation hood is 70 cm.

For details on this appliance, please refer to installation manual.

Appliance can be snapped into the worktop from above.

Appliance weight: approx. 16 kg.

Connection

Total connected load gas 18.0 MJ/h.

Total connected load electric 15 W.

Connecting cable 1.4 m with plug.

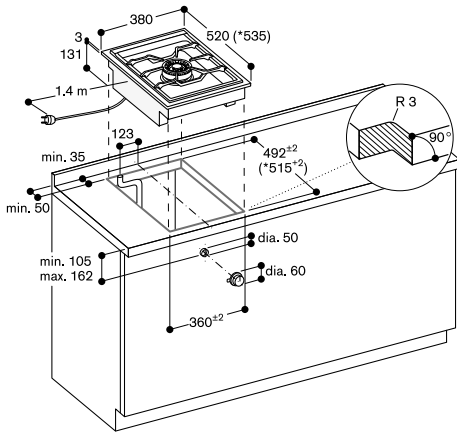

* with appliance cover or filler strip
See separate planning notes.

Installation of the control knob; surface mounting

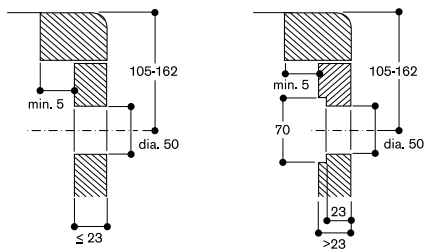

Gas connection

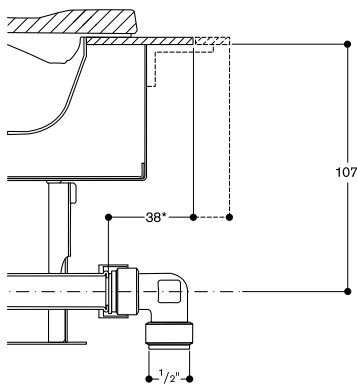

* 53 mm with appliance cover or filler strip.

Installation with appliance cover/spacer batten; installation flush with surrounding surfaces

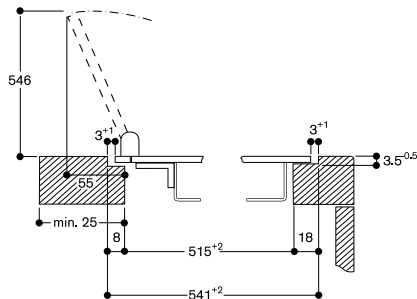

Installation with appliance cover/spacer batten; installation standing proud of surrounding surfaces

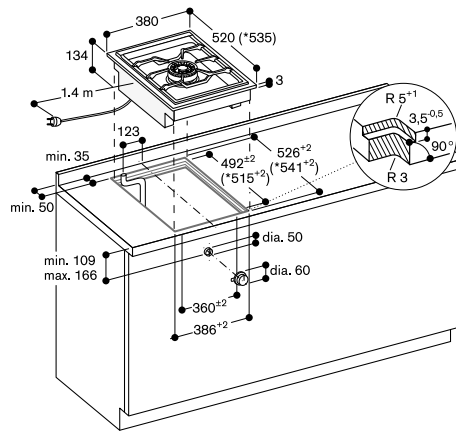
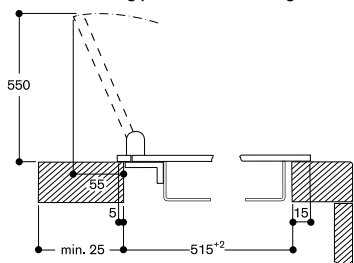

* with appliance cover or filler strip
See separate planning notes.

Installation of the control knob; flush installation

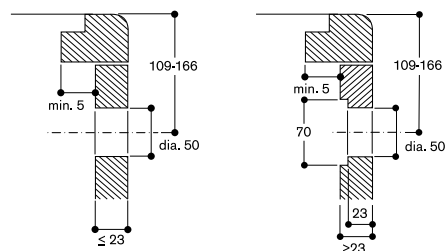

View from above

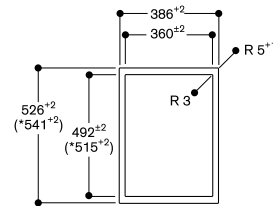

* with appliance cover or filler strip
(observe the front and rear asymmetrical support, see separate notes "Installation with appliance cover/filler strip").

Longitudinal section

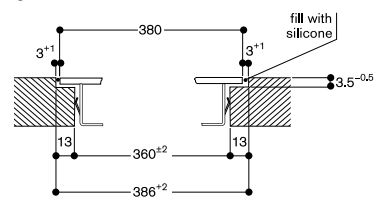

Cross-section

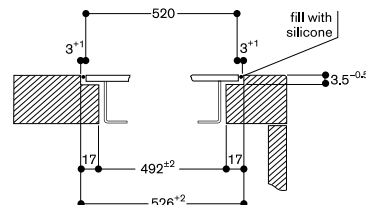

When installing with appliance cover or filler strip, pay attention to the deeper cut-out and the front and rear groove width.



VG 425 211 AU

Stainless steel
Width 38 cm
Natural gas 20.5 MJ/h
4 kW in 2 burners

Installation accessories

VA 420 010

Connection strip for combination with other Vario appliances of the 400 series for surface mounting

VA 420 011

Connection strip for combination with other Vario appliances of the 400 series for surface mounting with appliance cover/filler strip

VA 420 000

Connection strip for combination with other Vario appliances of the 400 series for flush mounting

VA 420 001

Connection strip for combination with other Vario appliances of the 400 series for flush mounting with appliance cover/filler strip

VA 440 010

Stainless steel appliance cover with mounting strip

VA 450 400

Stainless steel filler strip 38 cm
Necessary accessory for combination of several Vario appliances of the 400 series with at least one appliance cover to compensate the appliance depth.

Vario gas cooktop 400 series

VG 425

- 14 MJ/h high output burner
- Full electronic power level regulation on 12 levels
- Precise and reproducible flame size
- Automatic fast ignition, electronic flame monitoring with automatic reignition
- Simmer function for cooking on a very low output level
- Solid stainless steel control knob
- Precision crafting of 3 mm stainless steel
- For surface mounting with a visible edge or for flush mounting
- Can be combined perfectly with other Vario appliances of the 400 series

Cooking zones

1 two-ring high output burner
14.0 MJ/h, suitable for pots up to max. ø 28 cm.

1 two-ring standard output burner
6.5 MJ/h, suitable for pots up to max. ø 24 cm.

Handling

2 flexible installation control knobs (1.4m connecting cable)
Control knobs with illuminated ring, cooking zone and output level markings.

One-handed operation.
Full electronic control in 12 output levels for exact power level regulation plus simmer function.
Automatic fast ignition.

Features

Simmer function.
Cast pan support with flat, continuous pot surface.
Brass burner rings.

Safety

Electronic flame monitoring with automatic re-ignition.
Residual heat indication.
Safety shut-off.

Planning notes

Depending on the type of installation (surface-mounted or flush-mounted, with or without an appliance cover), the specific location of the cut-out and the knob positions may vary.

The drawing "Installation of the control knob" must be observed if the panel is more than 23 mm thick (there must be a recess at the rear).

If installing with the appliance cover VA 440 or filler strip VA 450 take into account the additional space required for the depth.

If combining several appliances with at least one appliance cover, the filler strip VA 450 is required to compensate for the depth of the appliance without the appliance cover.

If combining several Vario appliances of the 400 series, a connection strip VA 420 must be placed between the appliances.

Depending on the type of installation, the corresponding connection strip must be provided.

In the cut-out, the installation system requires the side edge to be at least 10 mm for surface mounting and at least 13 mm for flush mounting. Ensure a continuous cut surface of 90°.

The bearing capacity and stability, in the case of thin worktops in particular, must be supported using suitable substructures. Take into account the appliance weight and additional loads. Additional instructions for flush mounting:

Installation is possible in worktops made of stone, synthetics or solid wood. Heat resistance and watertight sealing of the cut edges must be observed. Concerning other materials please consult the worktop manufacturer.

The groove must be continuous and even, so that uniform placing of the appliance on the gasket is ensured. Do not use discontinuous lining. The joint width may vary due to size tolerances of the combinations and of the worktop cut-out.

Please read additional planning notes on page 72–77.

If installing several appliances in individual cut-outs allow for a division bar of minimum 50 mm between the individual cut-outs.

Special nozzles can be ordered as spare parts.

Plan for an electrical connection (the appliance is not operable without power supply).

Air intake from above.

No intermediate shelf required.

Rear panel and wall trims must be heat-resistant and consist of a nonflammable material.

A minimum clearance of at least 150 mm from adjacent heat-sensitive furniture or contact surfaces must be observed or thermal insulation fitted.

If operated next to the downdraft ventilation VL 414, the air baffle AA 414 is recommended to ensure maximum performance of the cooktop.

With a total connected load of more than 39.6 MJ/h local regulations concerning room ventilation, room size and combination of extraction or recirculation hoods must be observed.

Minimum clearance between gas cooktop(s) with more than 39.6 MJ/h and ventilation hood is 70 cm.

For details on this appliance, please refer to installation manual.

Appliance can be snapped into the worktop from above.

Appliance weight: approx. 14 kg.

Connection

Total connected load gas 20.5 MJ/h.

Total connected load electric 15.0 W.

Connecting cable 1.4 m with plug.

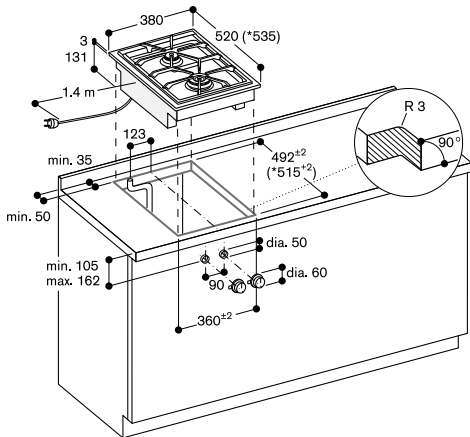

* with appliance cover or filler strip
See separate planning notes.

Installation of the control knob; surface mounting

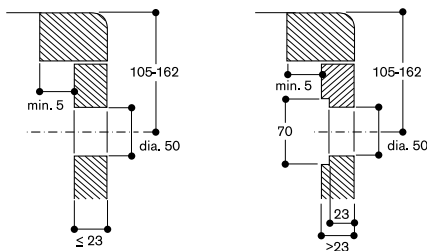

Gas connection

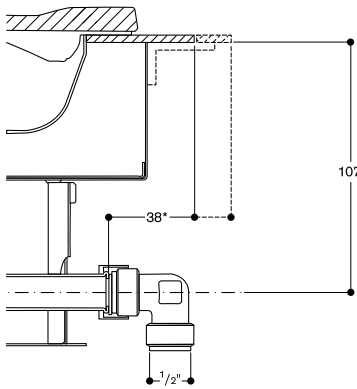

Installation with appliance cover/spacer batten; installation standing proud of surrounding surfaces

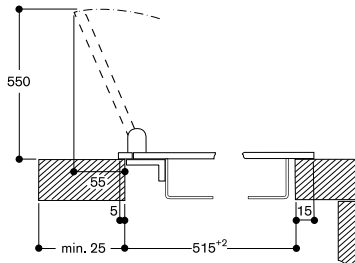

Installation with appliance cover/spacer batten; installation flush with surrounding surfaces

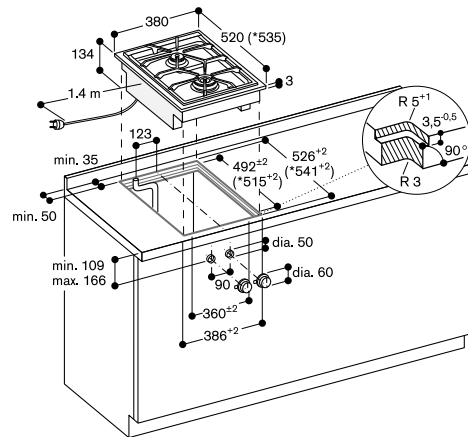
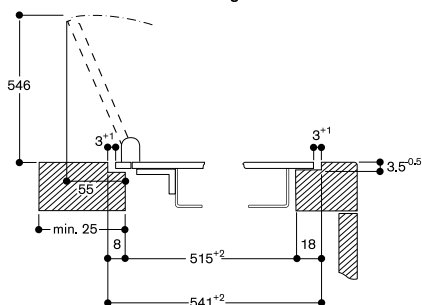

* with appliance cover or filler strip
See separate planning notes.

Installation of the control knob; flush installation

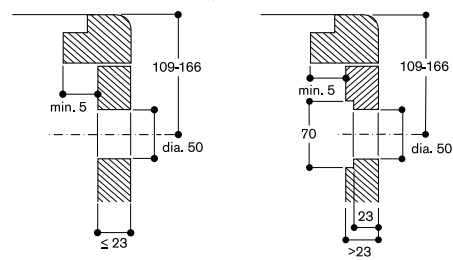

View from above

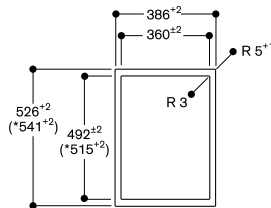

* with appliance cover or filler strip
(observe the front and rear asymmetrical support, see separate notes "Installation with appliance cover/filler strip").

Longitudinal section

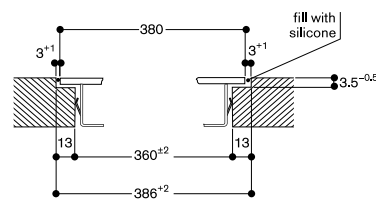

Cross-section

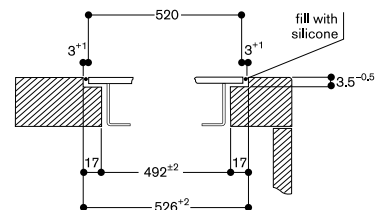

When installing with appliance cover or filler strip, pay attention to the deeper cut-out and the front and rear groove width.



VP 414 110

Stainless steel
Width 38 cm

Included in the price

2 spatula

Installation accessories**VA 420 010**

Connection strip for combination with other Vario appliances of the 400 series for surface mounting

VA 420 011

Connection strip for combination with other Vario appliances of the 400 series for surface mounting with appliance cover/filler strip

VA 420 000

Connection strip for combination with other Vario appliances of the 400 series for flush mounting

VA 420 001

Connection strip for combination with other Vario appliances of the 400 series for flush mounting with appliance cover/filler strip

VA 440 010

Stainless steel appliance cover with mounting strip

VA 450 400

Stainless steel filler strip 38 cm
Necessary accessory for combination of several Vario appliances of the 400 series with at least one appliance cover to compensate the appliance depth.

Vario Teppan Yaki 400 series**VP 414**

- Cooking directly on the hard-chromed metal surface, without any pots or pans
- Exact temperature control up to 240 °C
- Optimum heat distribution
- Solid stainless steel control knob
- Precision crafting of 3 mm stainless steel
- For surface mounting with a visible edge or for flush mounting
- Can be combined perfectly with other Vario appliances of the 400 series

Cooking zones

Usable area W 31 x D 44 cm.

Handling

2 fixed installation control knobs
Control knobs with illuminated ring, cooking zone and temperature markings.

Electronic temperature control from 120 °C to 240 °C.

Features

Two zones, each 1500 W, can be operated together as a complete surface or each half separately.

Keeping warm setting.

Even with traces of use, always easy to clean like a cast pan.

Safety

Safety shut-off.

Planning notes

Depending on the type of installation (surface-mounted or flush-mounted, with or without an appliance cover), the specific location of the cut-out and the knob positions may vary.

If installing with the appliance cover VA 440 or filler strip VA 450 take into account the additional space required for the depth.

If combining several appliances with at least one appliance cover, the filler strip VA 450 is required to compensate for the depth of the appliance without the appliance cover.

If combining several Vario appliances of the 400 series, a connection strip VA 420 must be placed between the appliances. Depending on the type of installation, the corresponding connection strip must be provided.

In the cut-out, the installation system requires the side edge to be at least 10 mm for surface mounting and at least 13 mm for flush mounting. Ensure a continuous cut surface of 90°.

The bearing capacity and stability, in the case of thin worktops in particular, must be supported using suitable substructures. Take into account the appliance weight and additional loads. Additional instructions for flush mounting:

Installation is possible in worktops made of stone, synthetics or solid wood. Heat resistance and watertight sealing of the cut edges must be observed. Concerning other materials please consult the worktop manufacturer. The groove must be continuous and even, so that uniform placing of the appliance on the gasket is ensured.

Do not use discontinuous lining. The joint width may vary due to size tolerances of the combinations and of the worktop cut-out.

Please read additional planning notes on page 72–77.

If installing several appliances in individual cut-outs allow for a division bar of minimum 50 mm between the individual cut-outs.

Built-in control panel to be integrated in the bottom cabinet at drawer level. Panel thickness 16 – 26 mm.

The drawing "Installation of the control knob" must be observed if the panel is more than 26 mm thick (there must be a recess at the rear).

A minimum lateral clearance of at least 40 mm from adjacent heat-sensitive furniture or contact surfaces must be observed or thermal insulation fitted.

Appliance can be snapped into the worktop from above.

Appliance weight: approx. 14 kg.

Connection

Total connected load 3.0 kW.

Power requirements

220 – 240 V / 50 – 60 Hz.

Plan a connection cable.



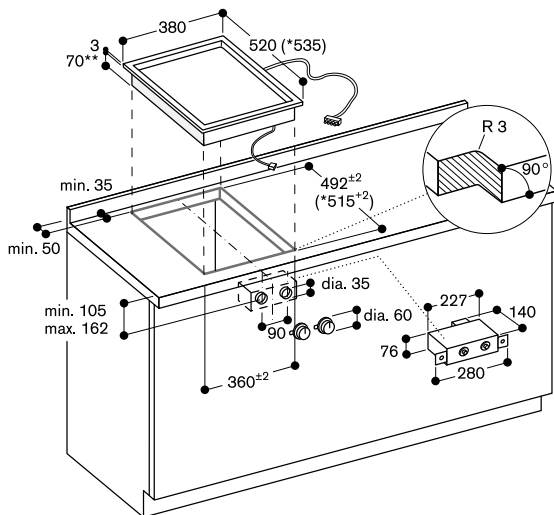

* with appliance cover or filler strip.
See separate planning notes.
** 80 mm in the area of the cable clamp (right, centre).

Installation of the control knob; surface mounting

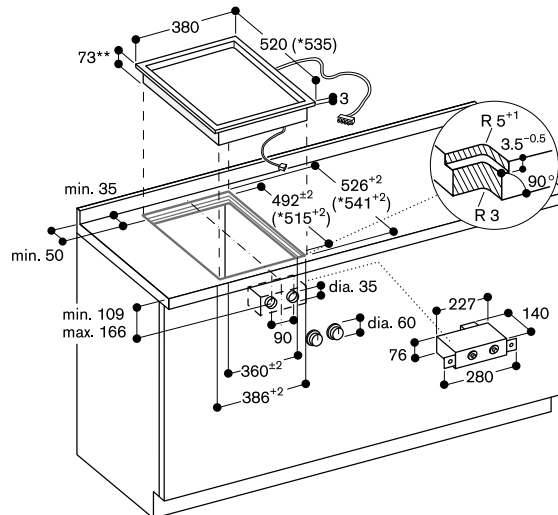
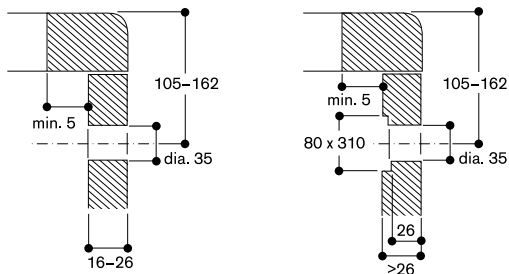

* with appliance cover or filler strip.
See separate planning notes.
** 83 mm in the area of the cable clamp (right, centre).

Installation of the control knob; flush mounting

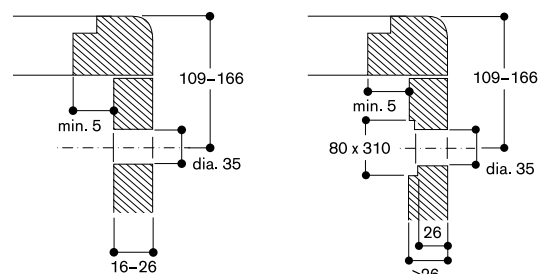

View from above

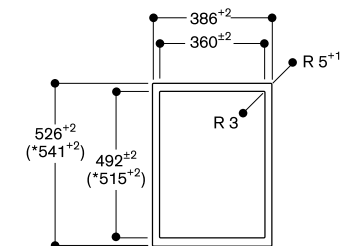

* with appliance cover or filler strip
(observe the front and rear asymmetrical support, see separate notes "Installation with appliance cover/filler strip").

Longitudinal section

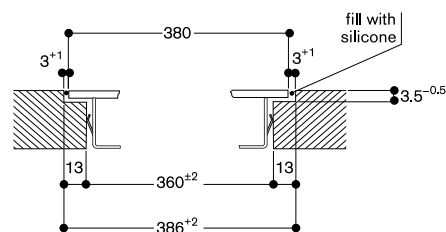

Cross-section

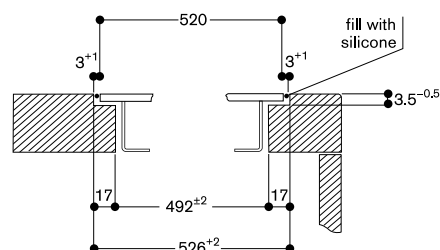

When installing with appliance cover or filler strip, pay attention to the deeper cut-out and the front and rear groove width.



VR 414 110

Stainless steel
Width 38 cm

Included in the price

- 1 cast pan, half size
- 1 grease collecting insert
- 2 cast grills
- 1 lava stone
- 1 cleaning brush

Installation accessories

VA 420 010

Connection strip for combination with other Vario appliances of the 400 series for surface mounting

VA 420 011

Connection strip for combination with other Vario appliances of the 400 series for surface mounting with appliance cover/filler strip

VA 420 000

Connection strip for combination with other Vario appliances of the 400 series for flush mounting

VA 420 001

Connection strip for combination with other Vario appliances of the 400 series for flush mounting with appliance cover/filler strip

VA 440 010

Stainless steel appliance cover with mounting strip

VA 450 400

Stainless steel filler strip 38 cm
Necessary accessory for combination of several Vario appliances of the 400 series with at least one appliance cover to compensate the appliance depth.

Special accessories

VA 461 001

Cast pan, enamelled, full size
For Vario electric grill 400 series.
For frying large quantities on one surface.

Vario electric grill 400 series

VR 414

- 2 separately controlled zones
- Cast pan, half size, for simultaneous frying and grilling on two separate surfaces
- Open cast grill, lava stones
- Solid stainless steel control knob
- Precision crafting of 3 mm stainless steel
- For surface mounting with a visible edge or for flush mounting
- Can be combined perfectly with other Vario appliances of the 400 series

Handling

2 fixed installation control knobs
Control knobs with illuminated ring, cooking zone and output level markings.
Electronic control in 12 output levels.

Features

Cooktop, lava stone trough and grease collecting insert from stainless steel.
2 independently controlled grilling elements (1500 W).
Two-part cast grill.

Safety

Safety shut-off.

Planning notes

Depending on the type of installation (surface-mounted or flush-mounted, with or without an appliance cover), the specific location of the cut-out and the knob positions may vary.

If installing with the appliance cover VA 440 or filler strip VA 450 take into account the additional space required for the depth.

If combining several appliances with at least one appliance cover, the filler strip VA 450 is required to compensate for the depth of the appliance without the appliance cover.

If combining several Vario appliances of the 400 series, a connection strip VA 420 must be placed between the appliances. Depending on the type of installation, the corresponding connection strip must be provided.

In the cut-out, the installation system requires the side edge to be at least 10 mm for surface mounting and at least 13 mm for flush mounting. Ensure a continuous cut surface of 90°.

The bearing capacity and stability, in the case of thin worktops in particular, must be supported using suitable substructures. Take into account the appliance weight and additional loads. Additional instructions for flush mounting:

Installation is possible in worktops made of stone, synthetics or solid wood. Heat resistance and watertight sealing of the cut edges must be observed. Concerning other materials please consult the worktop manufacturer.

The groove must be continuous and even, so that uniform placing of the appliance on the gasket is ensured. Do not use discontinuous lining. The joint width may vary due to size tolerances of the combinations and of the worktop cut-out.

Please read additional planning notes on page 72–77.

If installing several appliances in individual cut-outs allow for a division bar of minimum 50 mm between the individual cut-outs.

Built-in control panel to be integrated in the bottom cabinet at drawer level. Panel thickness 16 – 26 mm.

The drawing "Installation of the control knob" must be observed if the panel is more than 26 mm thick (there must be a recess at the rear).

A minimum lateral clearance of at least 100 mm from adjacent heat-sensitive furniture or from the wall must be observed.

Appliance can be snapped into the worktop from above.

Appliance weight: approx. 26 kg.

Connection

Total connected load 3.0 kW.

Power requirements

220 – 240 V / 50 – 60 Hz.

Plan a connection cable.

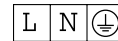

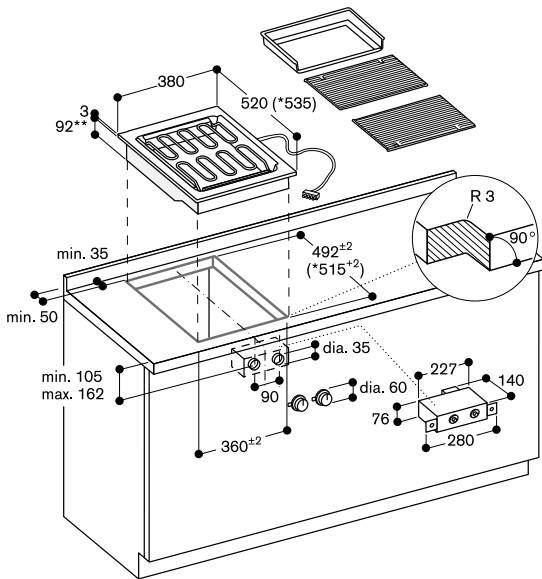

* with appliance cover or spacer batten.
See separate planning notes.
**102 mm in the area of the cable clip (right, centre).

Installation of the control knob; surface mounting

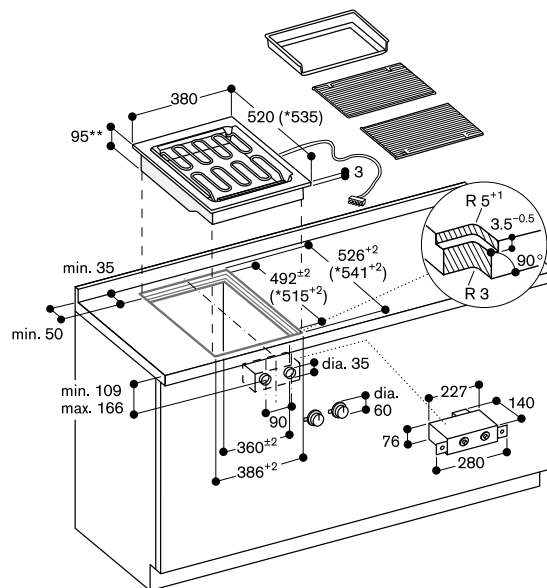
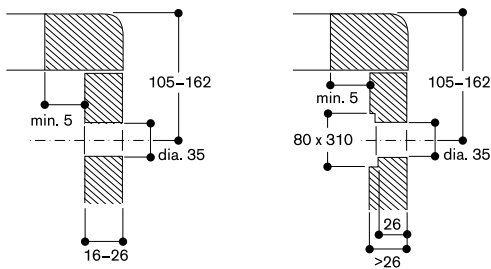

* with appliance cover or filler strip.
See separate planning notes.
** 105 mm in the area of the cable clamp (right, centre).

Installation of the control knob; flush mounting

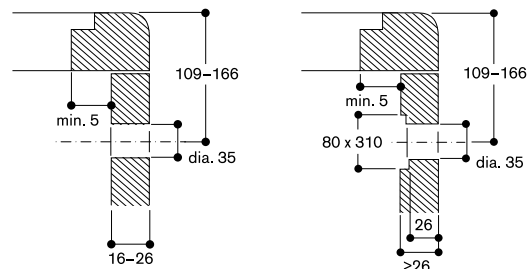

View from above

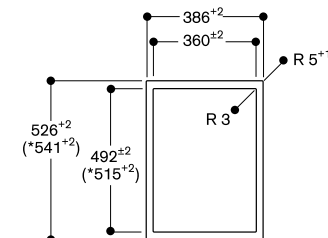

* with appliance cover or filler strip
(observe the front and rear asymmetrical support, see separate notes "Installation with appliance cover/filler strip").

Longitudinal section

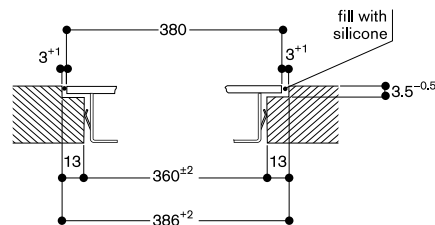

Cross-section

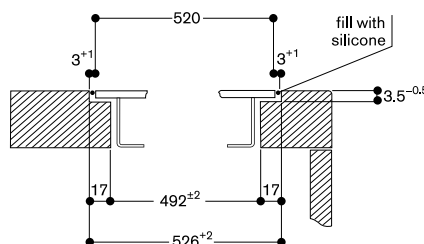

When installing with appliance cover or filler strip, pay attention to the deeper cut-out and the front and rear groove width.



VL 414 111

Stainless steel
Width 11 cm
Air extraction / Air recirculation
Without motor and control knob

Necessary installation accessories**AA 490 111**

Stainless steel control knob

AD 724 042

Connection piece for round pipe
DN 150 For VL 414
For installation to left or right side of
VL additional adapter AD 724 041 is
necessary.

AD 724 041

Round duct connection additional
adapter for VL 414 on the side
Metal zinc coated
Necessary for installation to left or
right side of VL.

AD 854 046

Flat duct system with guidance fins
Connecting piece VL 414 for
DN 150 flat

Installation accessories**VA 420 000**

Connection strip for combination
with other Vario appliances of the
400 series for flush mounting

VA 420 001

Connection strip for combination
with other Vario appliances of the
400 series for flush mounting
with appliance cover/filler strip

VA 420 010

Connection strip for combination
with other Vario appliances of the
400 series for surface mounting

VA 420 011

Connection strip for combination
with other Vario appliances of the
400 series for surface mounting
with appliance cover/filler strip

VA 450 110

Stainless steel filler strip 11 cm
Necessary accessory for combination
of several Vario appliances of the
400 series with at least one appliance
cover to compensate the appliance
depth.

Special accessories**AA 414 010**

Ventilation moulding for VL 414 next to
gas appliance.

Installation accessories for the air
recirculation ducts you will find on
pages 132 – 139.

Vario downdraft ventilation 400 series**VL 414**

- Highly efficient ventilation system at the cooktop
- Flexible power distribution, precise extraction of cooking vapours only at the open ventilation elements
- Can be combined perfectly with other Vario appliances of the 400 series
- Precision crafted 3 mm stainless steel
- For surface mounting with a visible edge or for flush mounting
- Motorless, can be combined with Gaggenau BLDC remote fan units

Output

Power levels depend on the remote fan unit, see page 104 – 105.

Features

Manual opening of the ventilation element.
Closing element made of stainless steel, dishwasher-safe.
Metal grease filter, dishwasher-safe.
No connecting piece included.

Consumption data

Consumption data is referred to a configuration with the remote fan unit AR 403 122.
Energy consumption 42.7 kWh/year.
Sound level min. 56 dB / max. 68 dB normal mode.

Planning notes

Refer to the table on page 104 for the matching remote fan units for air recirculation or air extraction mode. Secure the control unit to the side panel of the cabinet, not to the base of the cabinet or the kitchen floor. For each VL one remote fan unit is recommended.
Maximum cooktop width between two VL: 60 cm.
Appliance can be snapped into the worktop from above. Additional fixing by clamps accessible from bottom up, clamping range 30-50 mm.
If installing with the appliance cover VA 440 or filler strip VA 450 take into account the additional space required for the depth.
If combining several appliances with at least one appliance cover, the filler strip VA 450 is required to compensate for the depth of the appliance without the appliance cover.
If combining several Vario appliances of the 400 series, a connection strip VA 420 must be placed between the appliances. Depending on the type of installation, the corresponding connection strip must be provided. In the cut-out, the installation system requires the side edge to be at least 10 mm for surface mounting and at least 13 mm for flush mounting. Ensure a continuous cut surface of 90°. The bearing capacity and stability, in the case of thin worktops in particular, must be supported using suitable substructures.

Take into account the appliance weight and additional loads.

Additional instructions for flush mounting:

Installation is possible in worktops made of stone, synthetics or solid wood. Heat resistance and watertight sealing of the cut edges must be observed. Concerning other materials please consult the worktop manufacturer. The groove must be continuous and even, so that uniform placing of the appliance on the gasket is ensured. Do not use discontinuous lining. The joint width may vary due to size tolerances of the combinations and of the worktop cut-out.

If installing several appliances in individual cut-outs allow for a division bar of minimum 50 mm between the individual cut-outs.

If operated next to gas appliances, the ventilation moulding AA 414 010 is recommended to ensure maximum performance of the cooktop.

If installed next to gas appliances, flat ducts must not be used for the piping up to the fan unit.

If installed next to VP 414, the flat duct must not be positioned underneath the VP 414.

Please read the installation details regarding air ducting on page 114 – 115.

Please read additional planning notes on page 72–77.

Connection

Connection cable 2.0 m between ventilation element VL 414 and control knob AA 490.

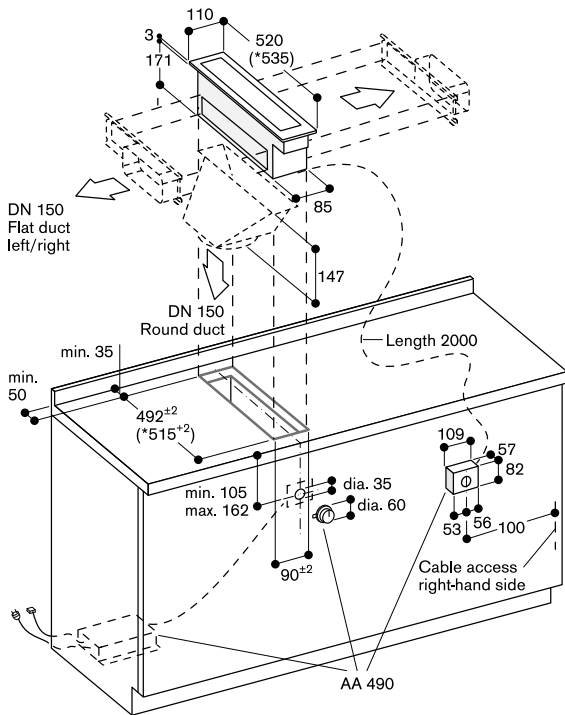

* with filler strip

- Flat duct pipe connection piece, left/right DN 150 with AD 854 046
- Round duct pipe connection piece, bottom DN 150 with AD 724 042
- Round duct pipe connection piece, left/right DN 150 with AD 724 042 + AD 724 041

See separate planning notes for
 - Positioning of control knob
 - Configuration for flexible power distribution

VL 414 with AD 724 042/041

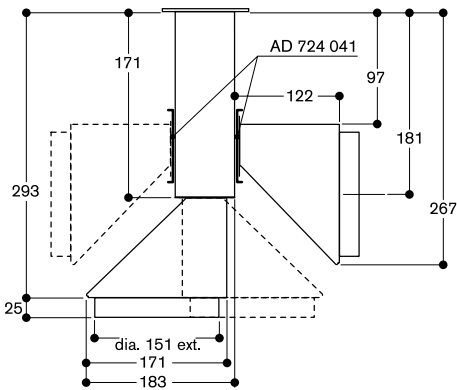

AD 854 046

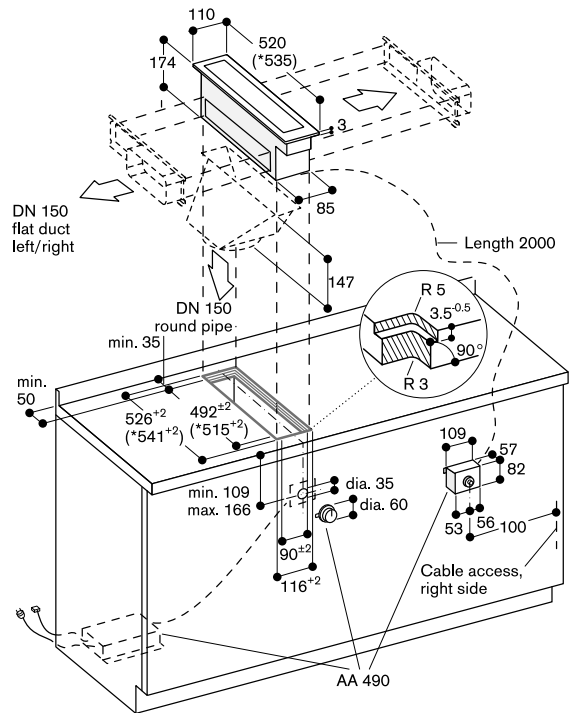
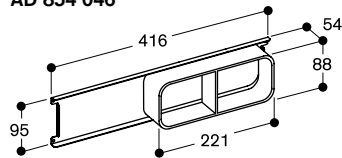

* with filler strip

- Flat duct pipe connection piece, left/right DN 150 with AD 854 046
- Round duct pipe connection piece, bottom DN 150 with AD 724 042
- Round duct pipe connection piece, left/right DN 150 with AD 724 042 + AD 724 041

See separate planning notes for
 - Positioning of control knob
 - Configuration for flexible power distribution

View from above

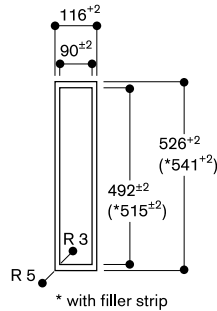

* with filler strip

Cross-section

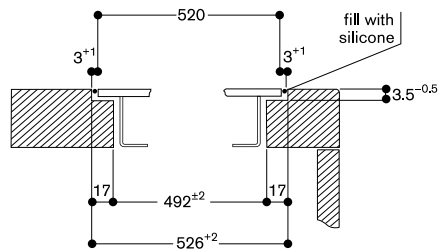

When installing with appliance cover or filler strip, pay attention to the deeper cut-out and the front and rear groove width.

Longitudinal section

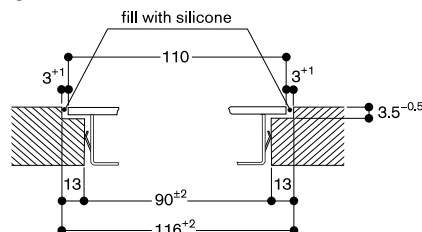



AA 490 111
Stainless steel

Vario control knob ventilation 400 series
AA 490

- Solid stainless steel control knob
- Can be combined perfectly with other Vario appliances of the 400 series
- Motorless, can be combined with Gaggenau BLDC remote fan units

Handling

Control knob with illuminated ring and output marking.

Features

3 electronically controlled power levels and 1 intensive mode.
Run-on function, 6 min.

Planning notes

The separate electronics housing is to be installed so that it is accessible.
Secure the control unit to the side panel of the cabinet, not to the base of the cabinet or the kitchen floor.
When installing a ventilation hood with air extraction mode and a chimney-vented fireplace, the power supply line of the ventilation appliance needs a suitable safety switch.

Connection

Total connected load 10W.
Connecting cable 1.8 m, with plug.

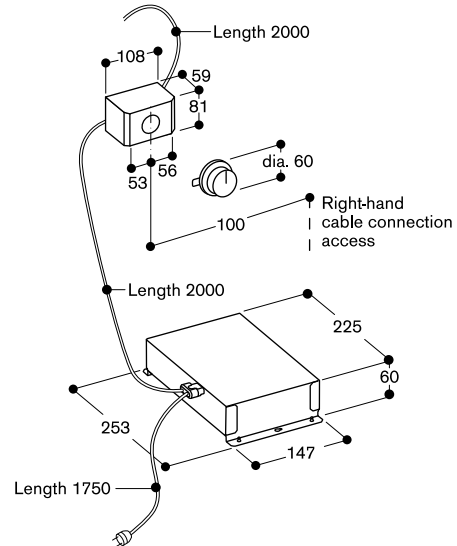





AL 400 121

Stainless steel
Width 120 cm
Air extraction / Air recirculation
Motorless

AL 400 191

Stainless steel
Width 90 cm
Air extraction / Air recirculation
Motorless

Necessary installation accessories

AD 754 045

Connection piece for 2 aluflex pipes
DN 150 round
Fitting AL 400, front or back side.

AD 854 043

Connecting piece for 2 flat ducts
DN 150
Fitting AL 400, bottom side.

AD 854 045

Connecting piece for 2 flat ducts
DN 150
Fitting AL 400, front or back side.

Installation accessories

AA 010 410

Air exhaust grill air recirculation
Stainless steel-coloured, 90 cm,
including installation fittings, height
adjustable.

AA 409 401

Furniture support for table ventilation
AL 400 90 cm
Can be combined with table ventilation
AL 400.
Recommended as bearer for the
worktop, instead of a cabinet frame.

AA 409 431

Furniture support for table ventilation
AL 400 120 cm
Can be combined with table ventilation
AL 400.
Recommended as bearer for the
worktop, instead of a cabinet frame.

AD 704 048

Air collector box DN 150 round pipe
2x DN 150 round duct air intake.
For connecting 1 x AL 400 to
AR 403/AR 413

AD 704 049

Air collector box DN 150 flat duct
2 x DN 150 flat duct air intake.
To connect 1 x AL 400 to remote fan
AR 403/AR 413 bottom side.

Installation accessories for the air
recirculation ducts you will find on
pages 132 – 139.

Table ventilation 400 series

AL 400

- Extendable table ventilation, when not in use can be completely lowered into the worktop
- Can be combined perfectly with other Vario appliances of the 400 series
- Dimmable, neutral white surface LED light for ideal illumination of the whole cooktop
- Precision crafted 3 mm stainless steel
- For surface mounting with a visible edge or for flush mounting
- Motorless, can be combined with Gaggenau BLDC remote fan units

Output

Power levels depend on the remote fan unit, see page 104 – 105.

Features

3 electronically controlled power levels and 1 intensive mode.
Interval ventilation, 6 min.
Run-on function, 6 min.
Grease filter saturation indicator.
Cartridge-type filter, dishwasher-safe.
Neutral white surface LED light (3600 K), continuously dimmable.
Lamp output 4x5 W.
Illuminance 191 lx.
Spare covers for closing air outlets.
No connecting piece included.

Consumption data

Consumption data is referred to a configuration AL 400 121/AL 400 191 with the remote fan unit AR 401 142.
Energy consumption 45.1/49 kWh/year.
Sound level min. 44/49 dB / max. 45/61 dB normal mode.

Planning notes

Refer to the table on page 104 for the matching remote fan units for air recirculation or air extraction mode.
Secure the control unit to the side panel of the cabinet, not to the base of the cabinet or the kitchen floor.
Connection to the respective appliances via network cable.
AL 400 121 (AL 400 191)
For operation with 4 (3) Vario 200 series cooktops, 3 (2) Vario 400 series cooktops or a cooktop configuration of up to 120 cm (92 cm) wide.
Operation of Vario cooking appliances only possible without appliance cover.
Max. output of cooktops 18 kW.
In combination with the cooktop CI 290, installation in 60 cm deep worktops is possible.
Installation is possible in worktops made of stone, synthetics or solid wood. Heat resistance and watertight sealing of the cut edges must be observed. Concerning other materials please consult the worktop manufacturer.

The remaining surface of the worktop (min. 50 mm) between the cut-outs must be reinforced with a support. It is recommended to use furniture support AA 409 401/431.

Ovens that do not exceed the maximum allowed cabinet temperature can be combined with the table ventilation if built-in situation permits.

To avoid smoke when frying/grilling refer to the manuals of VR/VP.

When installing a ventilation hood with air extraction mode and a chimney-vented fireplace, the power supply line of the ventilation appliance needs a suitable safety switch.

Please read additional planning notes on page 108 – 109.

Connection

Total connected load 65 W
Connecting cable 1.7 m, with plug.
Network cable 1.2 m.

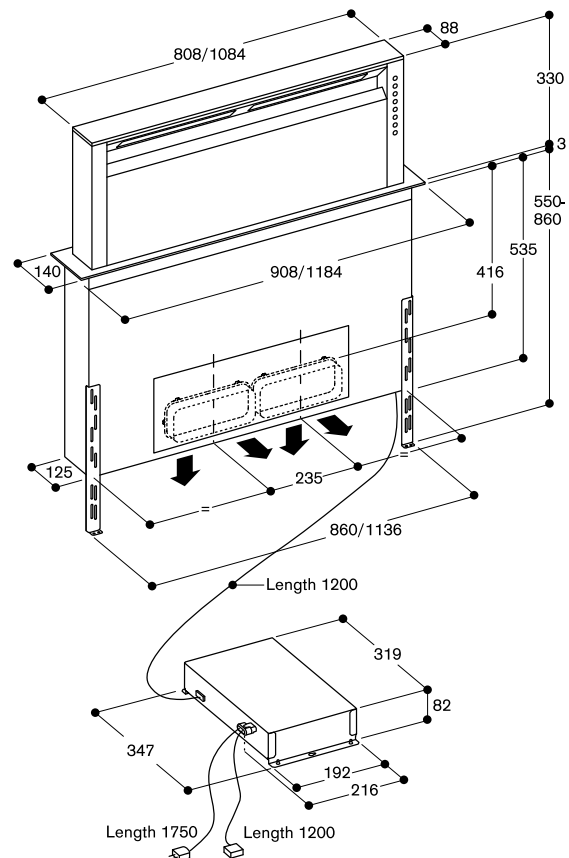

Pipe connection piece 2 x DN 150 front/rear
Flat duct using AD 854 045
Round duct using AD 754 045

Pipe connection piece 2 x DN 150 bottom
Flat duct using AD 854 043

AL 400 connection positions DN 150

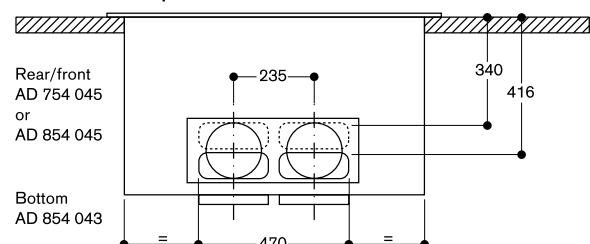

AA 010 410 air exhaust grille

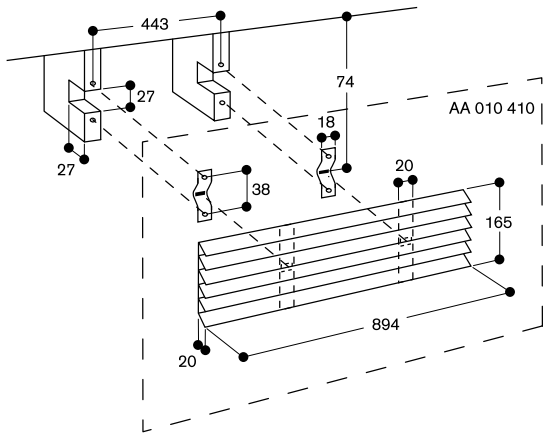

AD 754/854 045 and AD 854 043

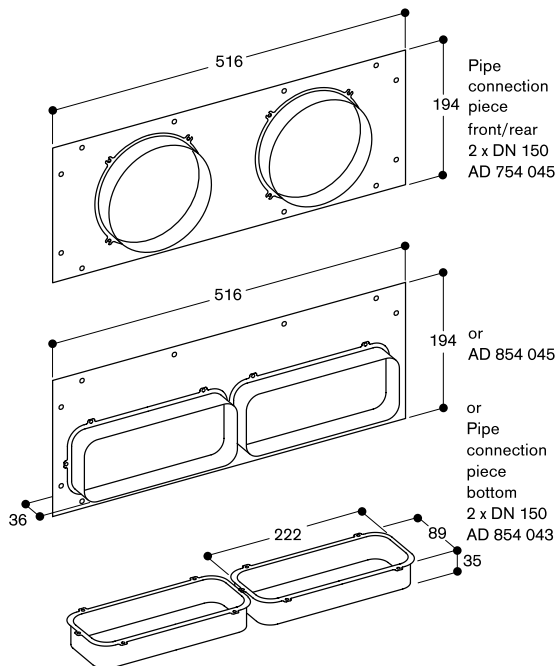

AA 409 401/431 furniture support

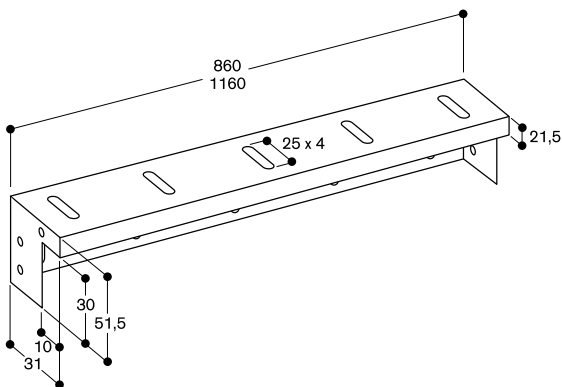

AL 400 installed flush

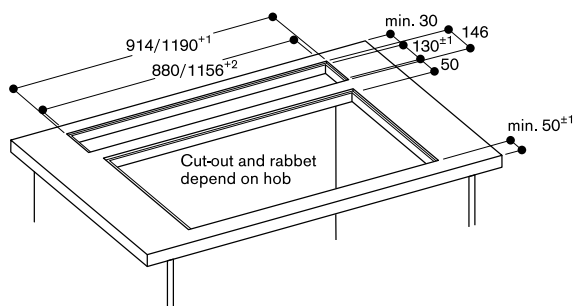

Longitudinal section

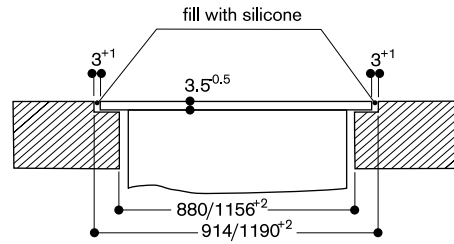

Cross-section

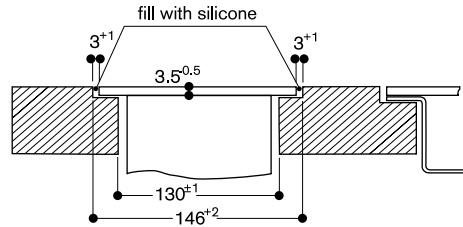

AL 400 cut-out flush-mounted

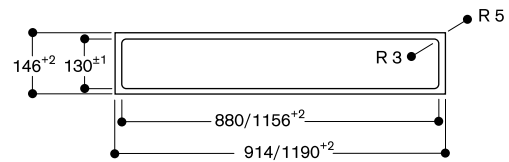

AL 400 cut-out for surface mounting

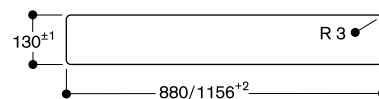

Cross-section of upper cabinet for AL 400 (without back wall) with AR 413; connection at the bottom

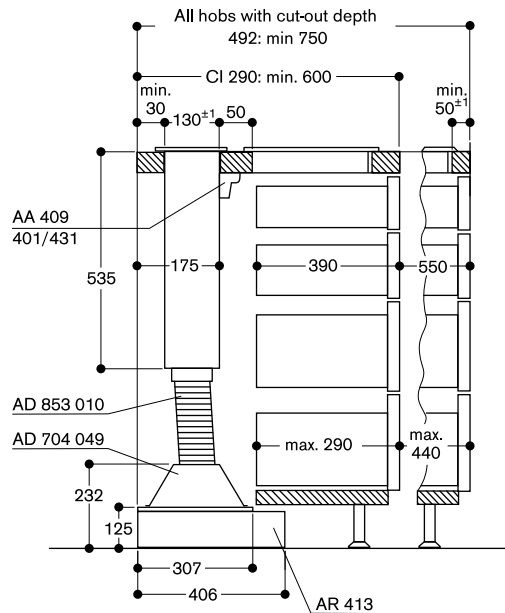

Cut-out dimensions for appliance combinations in the 400 series. Surface mounting.

The drawings listed below show the cut-out dimensions for appliance combinations in the 400 series for a surface mounting. While taking into consideration the previous page and the drawings specified below, the installer can define the suitable cut-out dimensions. The combinations listed here are only sample combinations.

Depending on the installation situation (with or without cover/filler strip), the following connection strips must be provided:
 VA 420 010 for a surface mounting **without** appliance cover/filler strip.
 VA 420 011 for a surface mounting **with** appliance cover/filler strip.

If installing with the VA 440 appliance cover or VA 450 filler strip, take into account the additional space required for the depth.

Sample combinations without VL 414 ventilation element:

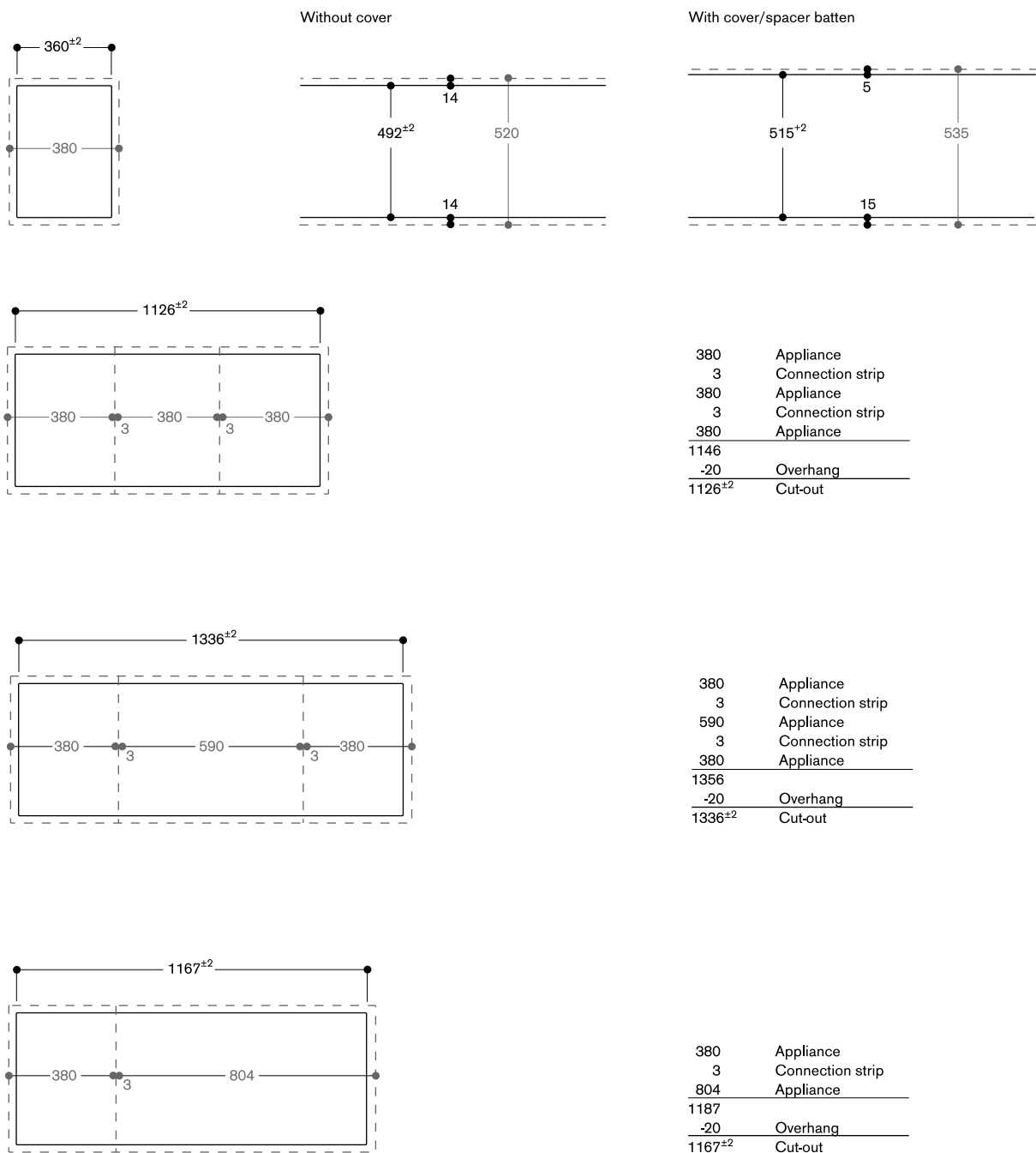

Sample combinations with VL 414 ventilation element:

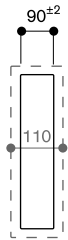

Without cover

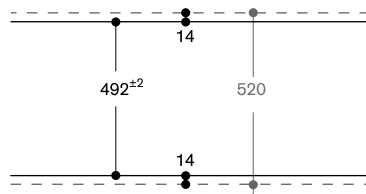

With cover/spacer batten

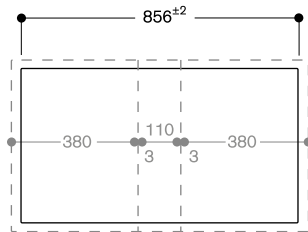
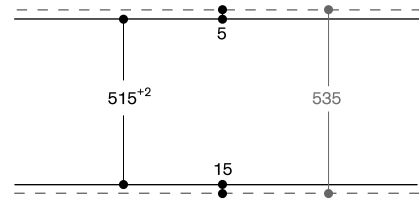

380	Appliance
3	Connection strip
110	VL
3	Connection strip
380	Appliance
<hr/>	
876	
-20	Overhang
856 ^{±2}	Cut-out

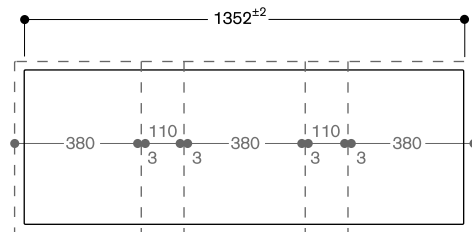

380	Appliance
3	Connection strip
110	VL
3	Connection strip
380	Appliance
3	Connection strip
110	VL
3	Connection strip
380	Appliance
<hr/>	
1372	
-20	Overhang
1352 ^{±2}	Cut-out

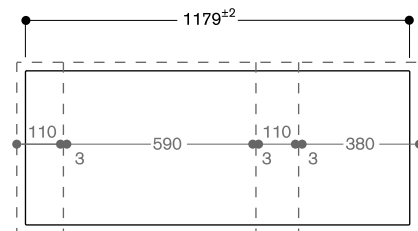

110	VL
3	Connection strip
590	Appliance
3	Connection strip
110	VL
3	Connection strip
380	Appliance
<hr/>	
1199	
-20	Overhang
1179 ^{±2}	Cut-out

Cut-out dimensions for appliance combinations in the 400 series. Flush mounting.

The drawings listed below show the cut-out dimensions for appliance combinations in the 400 series for a flush mounting. While taking into consideration the previous page and the drawings specified below, the installer can define the suitable cut-out dimensions. The combinations listed here are only sample combinations.

Depending on the installation situation (with or without cover/filler strip), the following connection strips must be provided:

VA 420 000 for a flush mounting **without** appliance cover/filler strip.

VA 420 001 for a flush mounting **with** appliance cover/filler strip.

If installing with the VA 440 appliance cover or VA 450 filler strip, take into account the additional space required for the depth. Furthermore, you must ensure that there is an asymmetrical alignment in the cut-out depth.

Sample combinations without VL 414 ventilation element:

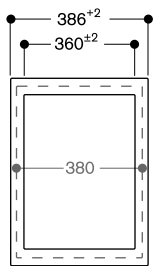

Without cover

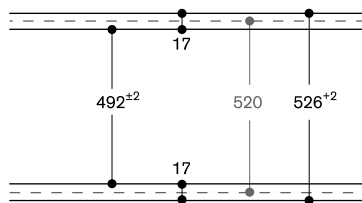

With cover/spacer batten

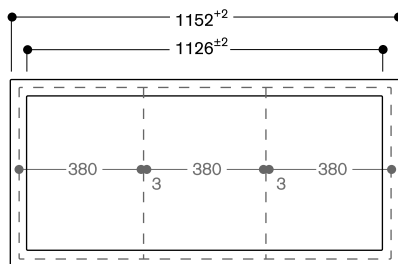
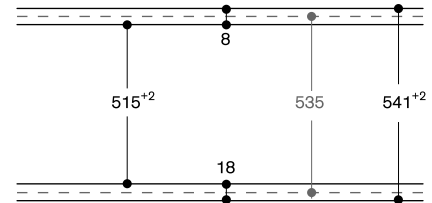

380	Appliance
3	Connection strip
380	Appliance
3	Connection strip
380	Appliance
<hr/>	
1146	
-20	Overhang
<hr/>	
1126 ^{±2}	Cut-out
+20	Overhang
+6	Silicone joint
<hr/>	
1152 ^{±2}	Cut-out with groove

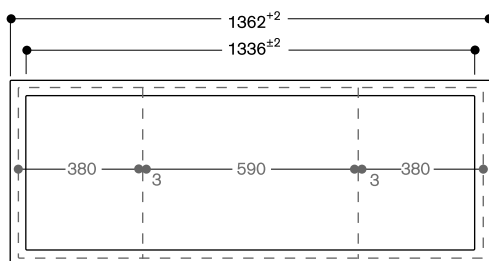

380	Appliance
3	Connection strip
590	Appliance
3	Connection strip
380	Appliance
<hr/>	
1356	
-20	Overhang
<hr/>	
1336 ^{±2}	Cut-out
+20	Overhang
+6	Silicone joint
<hr/>	
1362 ^{±2}	Cut-out with groove

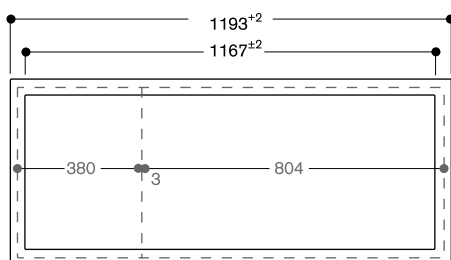

380	Appliance
3	Connection strip
804	Appliance
<hr/>	
1187	
-20	Overhang
<hr/>	
1167 ^{±2}	Cut-out
+20	Overhang
+6	Silicone joint
<hr/>	
1193 ^{±2}	Cut-out with groove

Sample combinations with VL 414 ventilation element:

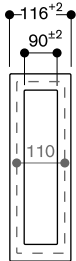

Without cover

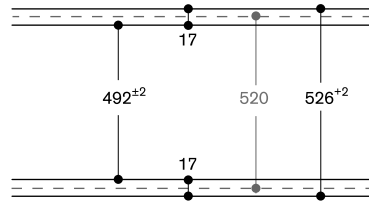

With cover/spacer batten

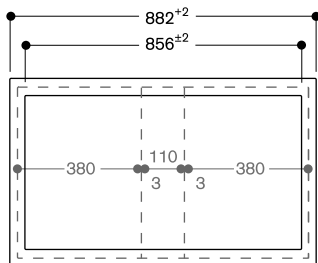
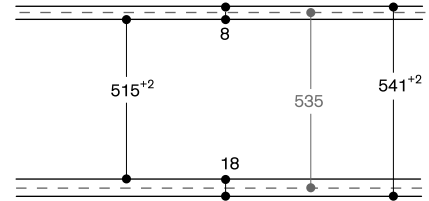

380	Appliance
3	Connection strip
110	VL
3	Connection strip
380	Appliance
<hr/>	
876	
-20	Overhang
<hr/>	
856±2	Cut-out
+20	Overhang
+6	Silicone joint
<hr/>	
882±2	Cut-out with groove

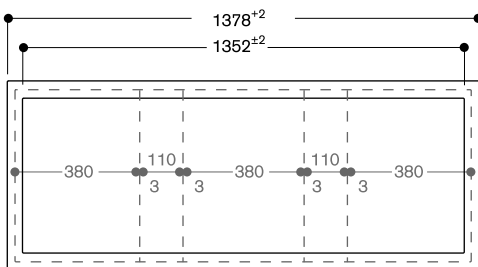

380	Appliance
3	Connection strip
110	VL
3	Connection strip
380	Appliance
3	Connection strip
110	VL
3	Connection strip
380	Appliance
<hr/>	
1372	
-20	Overhang
<hr/>	
1352±2	Cut-out
+20	Overhang
+6	Silicone joint
<hr/>	
1378±2	Cut-out with groove

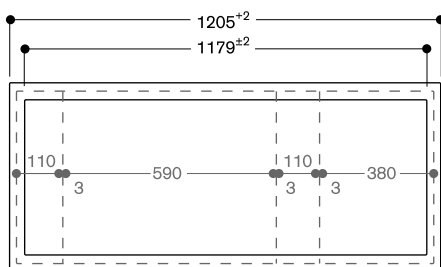

110	VL
3	Connection strip
590	Appliance
3	Connection strip
110	VL
3	Connection strip
380	Appliance
<hr/>	
1199	
-20	Overhang
<hr/>	
1179±2	Cut-out
+20	Overhang
+6	Silicone joint
<hr/>	
1205±2	Cut-out with groove

Cut-out dimensions for appliance combinations in the 400 series. Calculator for calculating the width of the cut-out.

Calculation of the width of the cut-out for a surface mounting

Example using a combination of VI 414, VI 422, VP 414 and 2 VL 414.

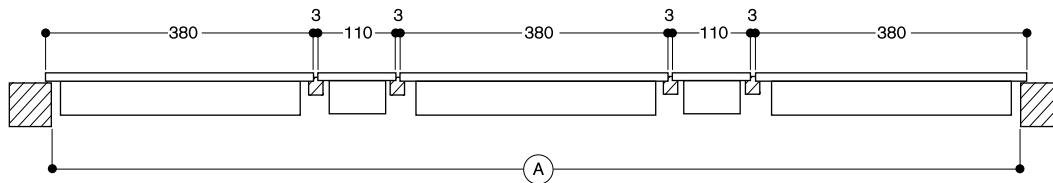

		Example		Your combination
Total width of all appliances	in mm	$(3 \times 380) + (2 \times 110)$	1.360
+ Number of connection strips	x 3 mm	4 x 3	+ 12
- Lateral appliance projection	(10 mm / side)	20	- 20	- 20
(A) Total width of the cut-out	(in mm)		1.352 +/- 2 +/- 2

Cut-out depth based on the installation situation with or without appliance cover/filler strip.

Calculation of the width of the cut-out for a flush mounting

Example using a combination of VI 414, VI 422, VP 414 and 2 VL 414.

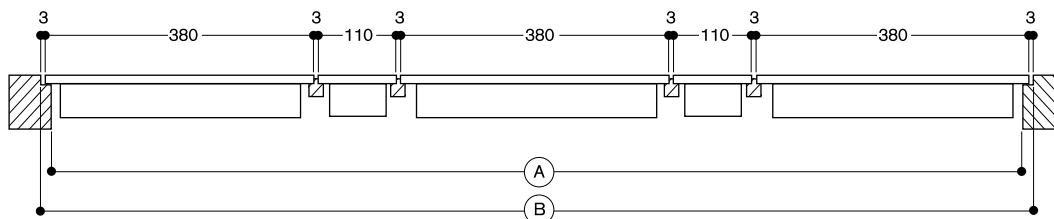

		Example		Your combination
Total width of all appliances	in mm	$(3 \times 380) + (2 \times 110)$	1.360
+ Number of connection strips	x 3 mm	4 x 3	+ 12
- Lateral appliance projection	(10 mm / side)	20	- 20	- 20
(A) Total width of the cut-out	(in mm)		1.352 +/- 2 +/- 2
+ Lateral appliance projection	(10 mm / side)	20	+ 20	+ 20
+ Silicone joint (3 mm circumference)		2 x 3	+ 6	+ 6
(B) Total width with groove	(in mm)		1.378 + 2 0/+ 2

Cut-out depth based on the installation situation with or without appliance cover/filler strip.

Installation with appliance cover and filler strip in the 400 series

All appliances with a width of 38 cm can be equipped with a stainless steel appliance cover. If combining several appliances with at least one appliance cover, the VA 450 filler strip is required to compensate for the depth of the appliance without the appliance cover and to have a continuous cut-out.

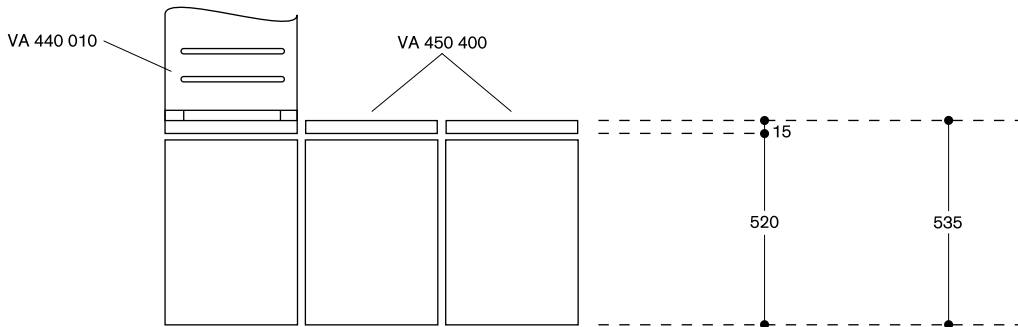

When installing with appliance cover or filler strip, depending on the mounting situation (surface or flush), the following connecting strips must be provided:

VA 420 011 for a **surface mounting** with appliance cover/filler strip.

VA 420 001 for a **flush mounting** with appliance cover/filler strip.

If installing with the VA 440 appliance cover or VA 450 filler strip, take into account the additional space required for the depth. Furthermore, you must ensure that there is an asymmetrical alignment in the cut-out depth.

Installation with appliance cover/spacer batten; installation standing proud of surrounding surfaces

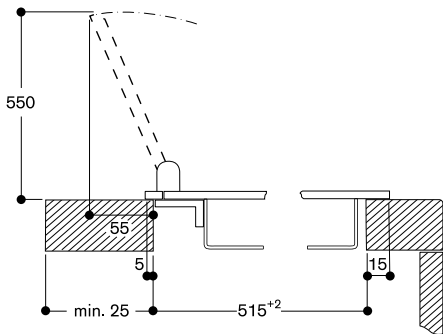

Installation with appliance cover/spacer batten; installation flush with surrounding surfaces

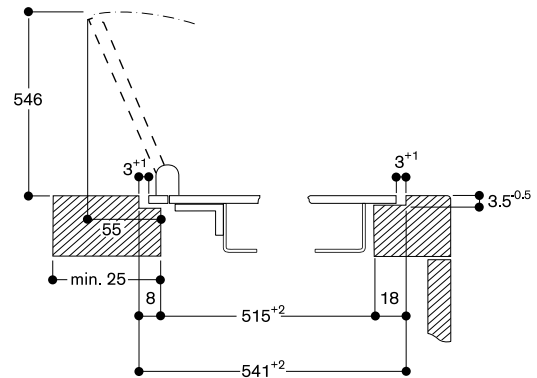



VI 262 120

Black control panel
Width 60 cm

Included in the price

1 glass scraper

Installation accessories

VV 200 010

Stainless steel connection strip for combination with other Vario appliances of the 200 series

VV 200 020

Black connection strip for combination with other Vario appliances of the 200 series

Special accessories

GP 900 003

Stainless steel frying sensor pan
Non-stick coating, ø 21 cm.

Vario flex induction cooktop 200 series

VI 262

- Electronic power control in 9 output levels
- Flex function for rectangular cooking areas
- Can be combined with the cooktops of the Vario 200 series
- Control panel for comfortable and secure operation

Cooking zones

2 flex induction cooking areas 19x23 cm (2200 W, with booster 3700 W), linked together 38x23 cm (3300 W, with booster 3700 W).

2 flex induction cooking areas 19x23 cm (2200 W, with booster 3700 W), linked together 38x23 cm (3300 W, with booster 3700 W).

Handling

Control knobs with illuminated ring.
Integrated control panel.

Features

Cooking area marking.
Frying sensor function.
Pot detection.
Booster function for each cooking area.

Safety

Residual heat indication.
Operation indicator.
Safety shut-off.

Planning notes

Operates with magnetic (induction) iron pots and pans only. For an optimal heat distribution, the use of sandwich bottom cookware is recommended.
Appliance can be snapped into the worktop from above.
Appliance weight: approx. 14 kg.

Please read additional planning notes on page 86.

Please read the installation details regarding air ducting on page 100.

Connection

Total connected load 7.4 kW.
Connecting cable 1.5 m without plug.

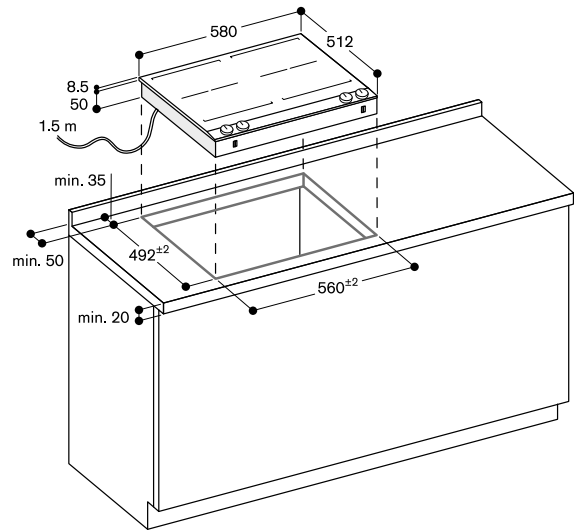
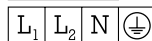
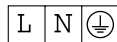



VG 264 220 AU

Black control panel
 Width 60 cm
 Natural gas 35.2 MJ/h
 Up to 9.8 kW on 4 burners

Installation accessories

VV 200 010

Stainless steel connection strip for combination with other Vario appliances of the 200 series

VV 200 020

Black connection strip for combination with other Vario appliances of the 200 series

**Vario gas cooktop 200 series
 VG 264**

- Mechanical power level regulation for 9 power levels, with exact setting and reproduction of flame size
- Can be combined with the cooktops of the Vario 200 series
- Control panel for comfortable and secure operation
- Solid smooth-surface cast pan supports for easy and safe positioning of cookware

Cooking zones

2 high output burner 10.8 MJ/h, suitable for pots up to max. ø 22 cm.
 2 standard burners 6.8 MJ/h, suitable for pots up to max. ø 20 cm.

Handling

Control knobs with illuminated ring.
 Integrated control panel.
 One-handed operation.
 Electric ignition.

Features

Two-part cast iron pan support with continuous pot surface.
 Enamelled burner cover.

Safety

Thermoelectric safety pilot.
 Residual heat indication.
 Operation indicator.

Planning notes

No intermediate shelf required.
 Appliance can be snapped into the worktop from above.
 A minimum lateral clearance of at least 150 mm from adjacent heat-sensitive furniture or contact surfaces must be observed or thermal insulation fitted.
 With a total connected load of more than 39.6 MJ/h local regulations concerning room ventilation, room size and combination of extraction or recirculation hoods must be observed.
 Minimum clearance between gas cooktop(s) with more than 39.6 MJ/h and ventilation hood is 70 cm.
 For details on this appliance, please refer to installation manual.
 Appliance weight: approx. 16 kg.

Please read additional planning notes on page 86.

Connection

Total connected load gas 35.2 MJ/h.
 Total connected load electric 10.0 W.
 Connecting cable 1.5 m with plug.

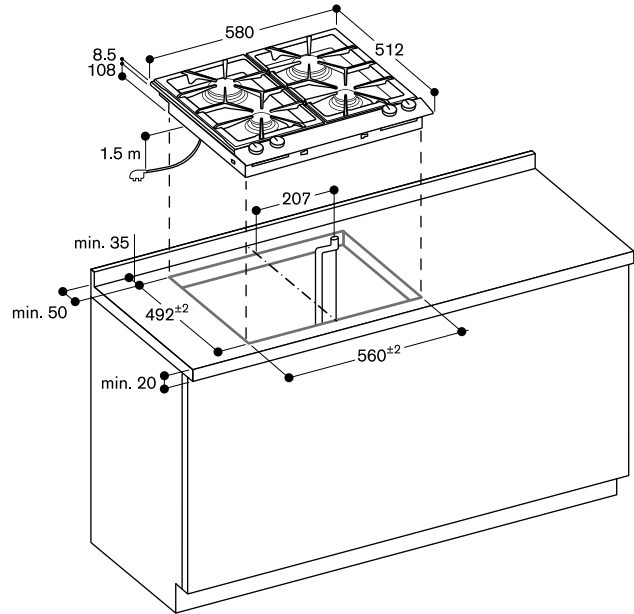

Minimum distance from the appliance cut-out to the side wall 150 mm.

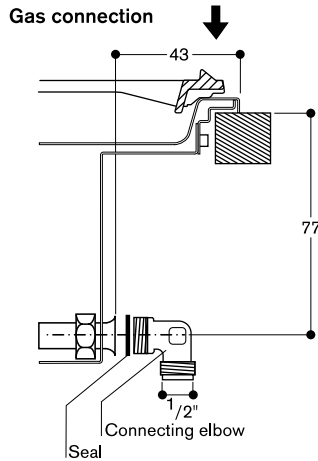



VI 232 120

Black control panel
Width 28 cm

Included in the price

1 glass scraper

Installation accessories

VV 200 010

Stainless steel connection strip for combination with other Vario appliances of the 200 series

VV 200 020

Black connection strip for combination with other Vario appliances of the 200 series

Special accessories

GP 900 003

Stainless steel frying sensor pan
Non-stick coating, ø 21 cm.

VD 200 020

Black appliance cover

Vario flex induction cooktop 200 series

VI 232

- Electronic power control in 9 output levels
- Flex function for rectangular cooking areas
- Can be combined with the cooktops of the Vario 200 series
- Control panel for comfortable and secure operation

Cooking zones

2 flex induction cooking areas 19x21 cm (2200 W, with booster 3700 W), linked together 38x21 cm (3300 W, with booster 3700 W).

Handling

Control knobs with illuminated ring.
Integrated control panel.

Features

Cooking area marking.
Frying sensor function.
Pot detection.
Booster function for both cooking areas.

Safety

Residual heat indication.
Operation indicator.
Safety shut-off.

Planning notes

Operates with magnetic (induction) iron pots and pans only. For an optimal heat distribution, the use of sandwich bottom cookware is recommended.
Appliance can be snapped into the worktop from above.
Appliance weight: approx. 7 kg.

Please read additional planning notes on page 86.

Please read the installation details regarding air ducting on page 100.

Connection

Total connected load 3.7 kW.
Connecting cable 1.5 m without plug.

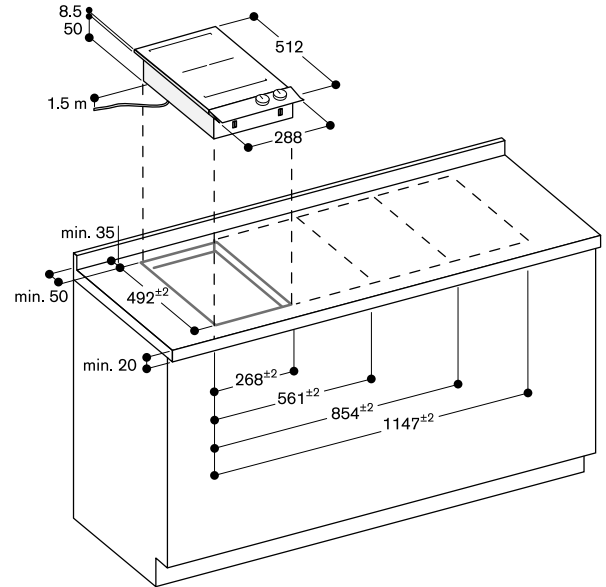
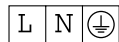



VG 231 220 AU

Black control panel
 Width 28 cm
 Natural gas 18 MJ/h
 Wok burner with up to 6 kW

Included in the price

1 wok attachment ring

Installation accessories

VV 200 010
 Stainless steel connection strip for combination with other Vario appliances of the 200 series

VV 200 020
 Black connection strip for combination with other Vario appliances of the 200 series

Special accessories

VD 200 020
 Black appliance cover

WP 400 001
 Wok pan made of multiple-layer material
 With round bottom and handle, ø36 cm, 6 litres, height 10 cm.

Vario gas wok 200 series
VG 231

- Mechanical power level regulation for 9 power levels, with exact setting and reproduction of flame size
- Can be combined with the cooktops of the Vario 200 series
- Control panel for comfortable and secure operation
- Multi-ring burner of solid, heat-resistant brass as used in professional kitchen
- 18 MJ/h wok burner

Cooking zones

1 multi-ring wok burner
 18 MJ/h, suitable for pots up to max. ø 30 cm.

Handling

Control knobs with illuminated ring.
 Integrated control panel.
 One-handed operation.
 Electric ignition.
 To close the cover, the cast iron pan support can be easily reversed.

Features

Cast iron pan support.
 Brass burner rings.

Safety

Thermoelectric safety pilot.
 Residual heat indication.
 Operation indicator.

Planning notes

Appliance can be snapped into the worktop from above.
 A minimum clearance of at least 150 mm from adjacent heat-sensitive furniture or contact surfaces must be observed or thermal insulation fitted.
 With a total connected load of more than 39.6 MJ/h local regulations concerning room ventilation, room size and combination of extraction or recirculation hoods must be observed.
 Minimum clearance between gas cooktop(s) with more than 39.6 MJ/h and ventilation hood is 70 cm.
 For details on this appliance, please refer to installation manual.
 Appliance weight: approx. 11 kg.

Please read additional planning notes on page 86.

Connection

Total connected load gas 18.0 MJ/h.
 Total connected load electric 10.0 W.
 Connecting cable 1.5 m with plug.

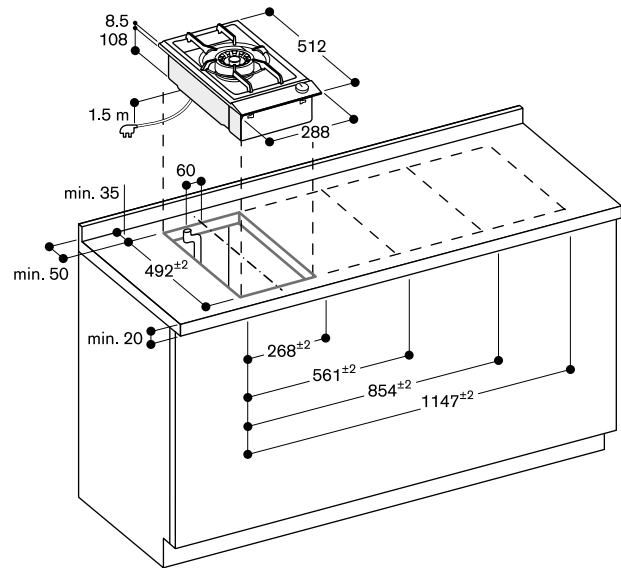

Minimum distance from the appliance cut-out to the side wall 150 mm.

Gas connection

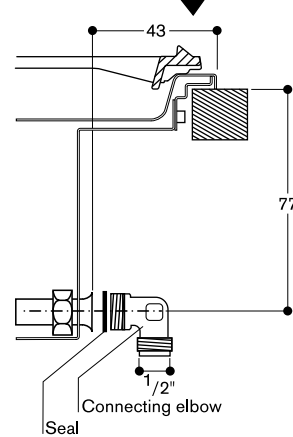



VG 232 220 AU

Black control panel

Width 28 cm

Natural gas 17.6 MJ/h

Installation accessories

VV 200 010

Stainless steel connection strip for combination with other Vario appliances of the 200 series

VV 200 020

Black connection strip for combination with other Vario appliances of the 200 series

Special accessories

VD 200 020

Black appliance cover

Vario gas cooktop 200 series

VG 232

- Mechanical power level regulation for 9 power levels, with exact setting and reproduction of flame size
- Can be combined with the cooktops of the Vario 200 series
- Control panel for comfortable and secure operation
- Solid smooth-surface cast pan supports for easy and safe positioning of cookware

Cooking zones

1 high output burner 10.8 MJ/h, suitable for pots up to max. \varnothing 22 cm.
1 standard burner 6.8 MJ/h, suitable for pots up to max. \varnothing 20 cm.

Handling

Control knobs with illuminated ring.
Integrated control panel.
One-handed operation.
Electric ignition.

Features

Cast pan support with continuous pot surface.
Enamelled burner cover.

Safety

Thermoelectric safety pilot.
Residual heat indication.
Operation indicator.

Planning notes

Appliance can be snapped into the worktop from above.
A minimum clearance of at least 150 mm from adjacent heat-sensitive furniture or contact surfaces must be observed or thermal insulation fitted.
With a total connected load of more than 39.6 MJ/h local regulations concerning room ventilation, room size and combination of extraction or recirculation hoods must be observed.
Minimum clearance between gas cooktop(s) with more than 39.6 MJ/h and ventilation hood is 70 cm.
For details on this appliance, please refer to installation manual.
Appliance weight: approx. 9 kg.

Please read additional planning notes on page 86.

Connection

Total connected load gas 17.6 MJ/h.
Total connected load electric 10.0 W.
Connecting cable 1.5 m with plug.

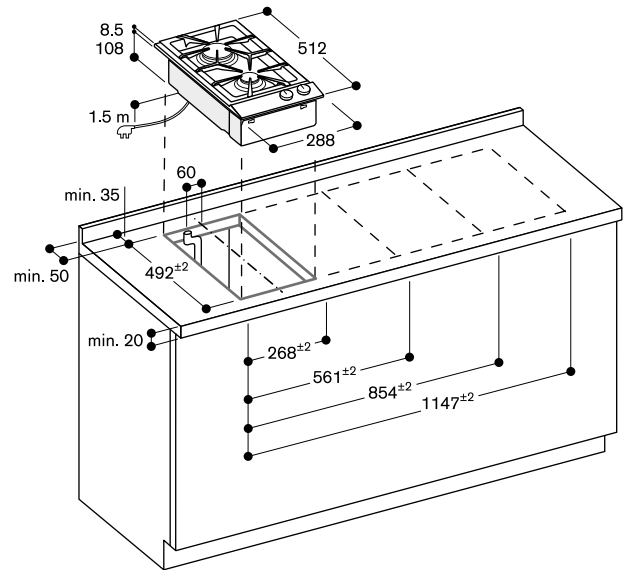

Minimum distance from the appliance cut-out to the side wall 150 mm.

Gas connection

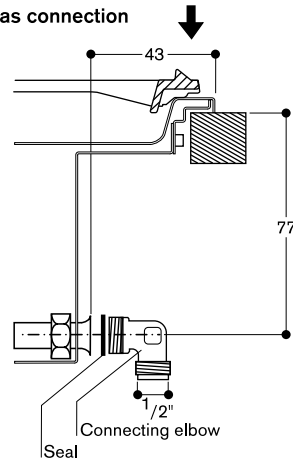

**VP 230 120**

Black control panel
Width 28 cm

Included in the price

1 spatula

Installation accessories**VV 200 010**

Stainless steel connection strip for combination with other Vario appliances of the 200 series

VV 200 020

Black connection strip for combination with other Vario appliances of the 200 series

Special accessories**VD 200 020**

Black appliance cover

Vario Teppan Yaki 200 series**VP 230**

- Exact temperature control up to 240 °C
- Can be combined with the cooktops of the Vario 200 series
- Control panel for comfortable and secure operation
- Cooking directly on the metal surface, without any pots or pans
- Keeping warm setting

Cooking zones

Useable area: 844 cm².

Handling

Control knobs with illuminated ring.
Integrated control panel.
Electronic temperature control from 140 °C to 240 °C.

Features

Heating element with 1800 W.
Keeping warm setting.
Cleaning stage.
Stainless steel frame seamlessly welded with the stainless steel surface.

Safety

Pre-heat and residual heat indicator.
Operation indicator.
Safety shut-off.

Planning notes

The distance from the upper edge of the work surface to the upper edge of the intermediate shelf must be at least 150 mm.

Appliance can be snapped into the worktop from above.

A minimum lateral clearance of at least 30 mm from adjacent heat-sensitive furniture or contact surfaces must be observed or thermal insulation fitted.

Intermediate shelf required; after installation, this shelf must only be removed using tools to guarantee the touch protection from below.

Appliance weight: approx. 10 kg.

Please read additional planning notes on page 86.

Connection

Total connected load 1.8 kW.
Connecting cable 1.8 m without plug.

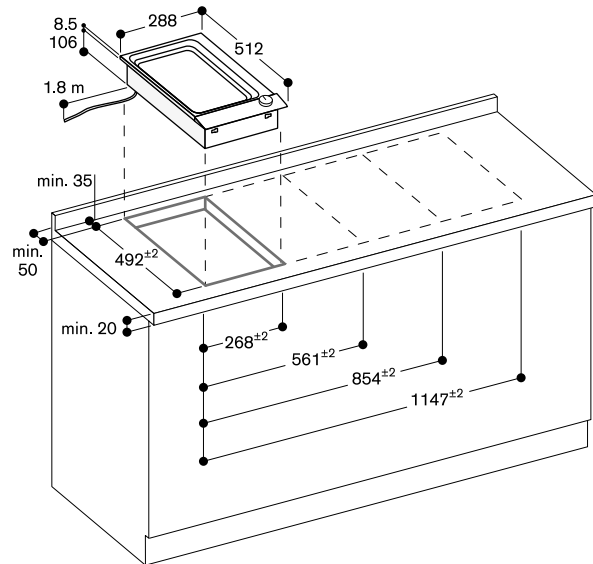



VR 230 120

Black control panel
Width 28 cm

Included in the price

- 1 grease collecting insert
- 1 cast grill
- 1 lava stone
- 1 cleaning brush

Installation accessories

VV 200 010

Stainless steel connection strip for combination with other Vario appliances of the 200 series

VV 200 020

Black connection strip for combination with other Vario appliances of the 200 series

Special accessories

VD 200 020

Black appliance cover

Vario electric grill 200 series

VR 230

- Can be combined with the cooktops of the Vario 200 series
- Control panel for comfortable and secure operation
- 2 zones, separately controlled
- Open cast grill, lava stones

Handling

Control knobs with illuminated ring.
Integrated control panel.
9 switching levels.

Features

2 separately controllable swing-out grilling elements (1500 W).
Join function.
Cast grill.
Stainless steel lavastone container and grease collecting insert, dishwasher-safe.

Safety

Pre-heat and residual heat indicator.
Operation indicator.
Safety shut-off.

Planning notes

Appliance can be snapped into the worktop from above.
A minimum clearance of at least 200 mm from adjacent heat-sensitive furniture or contact surfaces must be observed or thermal insulation fitted.
Appliance weight: approx. 15 kg.

Please read additional planning notes on page 86.

Connection

Total connected load 3.0 kW.
Connecting cable 1.8 m without plug.

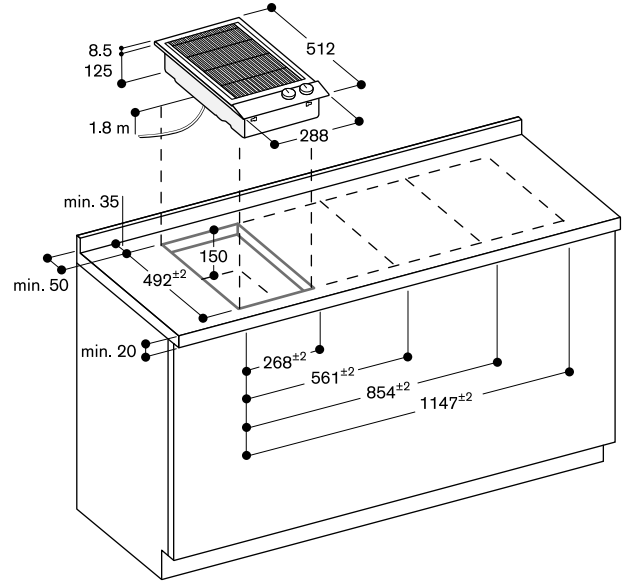



VL 200 120
 Black control panel
 Width 15 cm
 Air extraction / Air recirculation
 Motorless

Installation accessories

- AD 410 040**
Flexible connecting piece for VL 200
DN 150 flat
- AD 851 041**
Connecting piece VL 200 for extension
with flat duct DN 150 for extra deep
worktop
- VV 200 010**
Stainless steel connection strip for
combination with other Vario
appliances of the 200 series
- VV 200 020**
Black connection strip for combination
with other Vario appliances of the
200 series

Special accessories

LS 041 001
 Ventilation moulding for VL 200 next to
 gas appliance
 Stainless steel

**Installation accessories for the air
 recirculation ducts you will find on
 pages 132 – 139.**

**Vario downdraft ventilation 200 series
 VL 200**

- Can be combined with the cooktops of the Vario 200 series
- Highly efficient ventilation system at the cooktop integrated in the worktop
- Function for automatic, sensor-controlled power adjustment depending on the build-up of cooking vapours
- Minimal planning and easy installation
- Air extraction or air recirculation system

Output
 Power levels depend on the remote fan unit, see page 104 – 105.

Features
 Control knobs with illuminated ring.
 3 electronically controlled power levels and 1 intensive mode.
 Automatic function with sensor-controlled run-on function.
 Large-scale metal grease filter with high grease absorption.
 Grease filter, dishwasher-safe.
 Grease filter and activated charcoal filter saturation indicator.
 Airflow-optimised interior for efficient air circulation.
 Interval ventilation, 6 min.
 Enamelled ventilation grill, dishwasher-safe.
 Air exhaust bend included in delivery.
 Overflow 250 ml capacity.

Consumption data
 Consumption data is referred to a configuration with the remote fan unit AR 403 122.
 Energy consumption 39.7 kWh/year.
 Sound level min. 58 dB / max. 73 dB normal mode.

Planning notes
 Air recirculation mode in combination with remote fan unit with AR 410 110 or AR 413 122.
 Air extraction in combination with remote fan unit AR 403 122 or AR 401 142 (outside motor).
 Please refer to page 104, 118 – 119 for recommended configurations of downdraft ventilations and remote fan units and the needed ducting elements.
 For each VL one remote fan unit is recommended.
 Maximum cooktop width between 2 VL: 60 cm.
 If installed next to gas appliances, the ventilation moulding LS 041 001 is recommended to ensure maximum performance of the cooktop.
 When having installed the ventilation moulding LS 041 001 the wok pan WP 400 001 can not be used.

When installing a ventilation hood with air extraction mode and a chimney-vented fireplace, the power supply line of the ventilation appliance needs a suitable safety switch.

Please read additional planning notes on page 86.
 Please read the installation details regarding air ducting on page 118 – 119.

Connection
 Connecting cable 1.7 m between VL and remote fan unit.

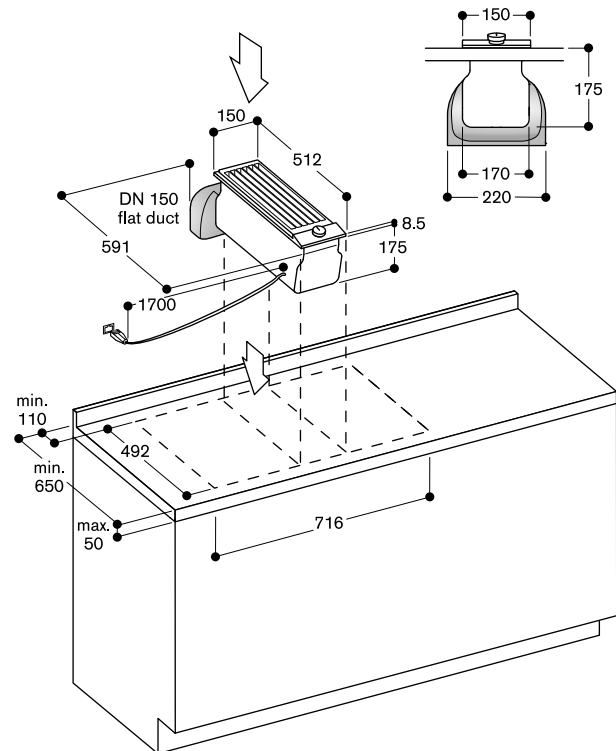

AD 410 040: Flexible connecting piece for VL 200, DN 150 flat

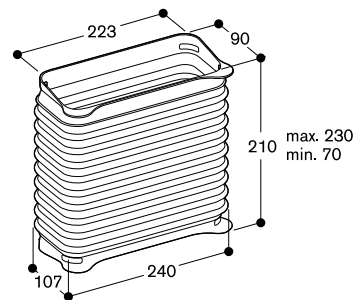

AD 851 041: Connecting piece VL 200 for extension with flat duct DN 150 for extra deep worktop

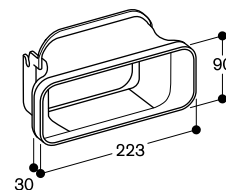

Cut-out dimensions for cooktop combinations in the 200 series

The drawings below show the cut-out dimensions for cooktop combinations of the 200 series. The technician can find the suitable cut-out dimensions for the combinations most frequently used by referring to the previous pages and the drawings below.

Cut-out dimensions for the Vario 200 series

288	Appliance
- 20	Overhang
268	Cut-out

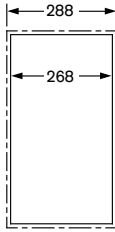

288	Appliance
5	VV 200
288	Appliance
581	
- 20	Overhang
561	Cut-out

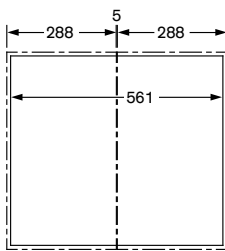

288	Appliance
5	VV 200
288	Appliance
5	VV 200
288	Appliance
874	
- 20	Overhang
854	Cut-out

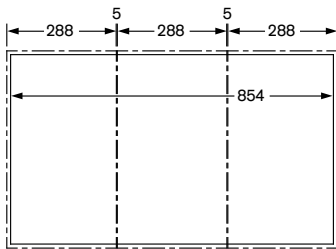

288	Appliance
5	VV 200
288	Appliance
5	VV 200
288	Appliance
5	VV 200
288	Appliance
1.167	
- 20	Overhang
1.147	Cut-out

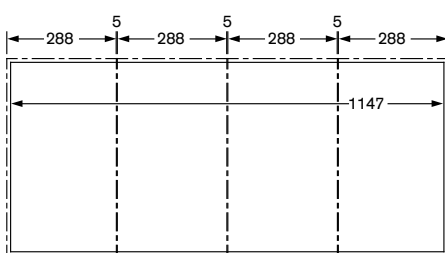

288	Appliance
5	VV 200
580	Appliance
873	
- 20	Overhang
853	Cut-out

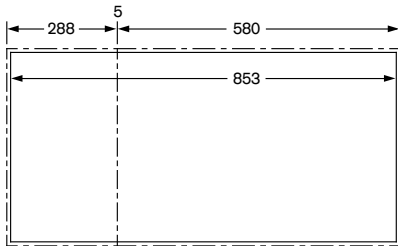

Cut-out dimensions for the Vario 200 series with downdraft

288	Appliance
5	VV 200
150	VL 200
5	VV 200
288	Appliance
736	
- 20	Overhang
(10 + 10)	
716	Cut-out

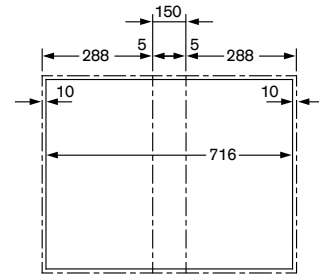

288	Appliance
5	VV 200
150	VL 200
443	
- 20	Overhang
(10 + 10)	
423	Cut-out

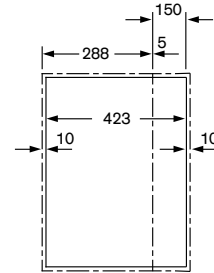

150	VL 200
5	VV 200
580	Appliance
5	VV 200
150	VL 200
890	
- 20	Overhang
(10 + 10)	
870	Cut-out

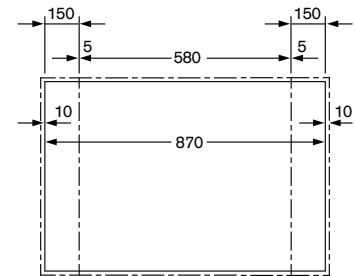

288	Appliance
5	VV 200
150	VL 200
5	VV 200
580	Appliance
5	VV 200
150	VL 200
1183	
- 20	Overhang
(10 + 10)	
1163	Cut-out

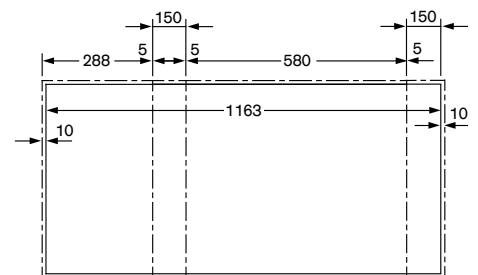

Accessories and special accessories for Vario cooktops 400 series

VA 440 010

Stainless steel appliance cover with mounting strip



VA 461 001

Cast pan, enamelled, full size
For Vario electric grill 400 series.
For large quantities on one surface.



WP 400 001

Wok pan made of multiple-layer material
With round bottom and handle,
ø 36 cm, 6 litres, height 10 cm.



WZ 400 001

Wok attachment for wok pan



GP 900 003

Stainless steel frying sensor pan
Non-stick coating, ø 21 cm.



GP 900 004

Stainless steel frying sensor pan
Non-stick coating, ø 28 cm.



AA 414 010

Air baffle for downdraft ventilation
when installation next to gas cooktops



VA 420 000

Connection strip for combination
with other Vario appliances of the
400 series for flush mounting



VA 420 001

Connection strip for combination
with other Vario appliances of the
400 series for flush mounting with
appliance cover/filler strip



VA 420 010

Connection strip for combination
with other Vario appliances of the
400 series for surface mounting



VA 420 011

Connection strip for combination
with other Vario appliances of the
400 series for surface mounting
with appliance cover/filler strip



VA 450 110

Adjustment strip if one cooktop
adjacent has a lid



VA 450 400

Stainless steel filler strip 38 cm
Necessary accessory for combination
of several Vario appliances of the
400 series with at least one appliance
cover to compensate the appliance
depth.



VA 450 401

Stainless steel filler strip 38 cm
Necessary accessory for combination
of several Vario appliances of the
400 series with at least one appliance
cover to compensate the appliance
depth.



VA 450 600

Stainless steel filler strip 60 cm
Necessary accessory for combination
of several Vario appliances of the
400 series with at least one appliance
cover to compensate the appliance
depth.



VA 450 800

Stainless steel filler strip 80 cm
Necessary accessory for combination
of several Vario appliances of the
400 series with at least one appliance
cover to compensate the appliance
depth.



AD 724 042

Connection piece for round pipe
DN 150
For VL 414
For installation to left or right side of
VL additional adaptor AD 724 041 is
necessary.



AD 724 041

Round duct connection
additional adaptor for
VL 414 on the side
Metal zinc plated
DN 150 round
One piece needed for each VL 414
to be connected to round ducts
DN 150 to the left/right.



AD 854 046

Flat duct system with conducting fins
Connection piece VL 414 for DN 150
flat rectangular
Allows for long duct runs with highest
efficiency due to soft duct shape and
conducting fins within the duct bends
Compact installation height even with
DN 150 allows integration in floor
constructions



Accessories and special accessories for Vario cooktops 200 series

VD 200 020

Black appliance cover



LS 041 001

Air baffle for VL 200 next to gas appliance



VV 200 010

Stainless steel connection strip for combination with other Vario appliances of the 200 series.



VV 200 020

Black connection strip for combination with other Vario appliances of the 200 series.



WP 400 001

Wok pan made of multiple-layer material

With round bottom and handle, ø36 cm, 6 litres, height 10 cm.



WZ 400 001

Wok attachment for wok pan



GP 900 003

Stainless steel frying sensor pan
Non-stick coating, ø21 cm.



AD 410 040

Flexible connecting piece for VL 200
DN 150 flat



AD 851 041

Connecting piece VL 200 for extension with flat duct DN 150 for extra deep worktop





The cooktops

Gas cooktops	92
Induction cooktops	94
Planning notes for induction cooktops	100
Accessories special accessories	101



VG 295 220 AU

Black control panel
Width 90 cm
Natural gas 61.2 MJ/h
Up to 18 kW on 5 burners

Included in the price

1 wok attachment ring

Special accessories

WP 400 001

Wok pan made of multiple-layer material
With round bottom and handle, ø36 cm, 6 litres, height 10 cm.

Gas cooktop 200 series

VG 295

- 18 MJ/h wok burner
- Control panel for comfortable and secure operation
- Mechanical power level regulation for 9 power levels, with exact setting and reproduction of flame size
- Multi-ring burner of solid, heat-resistant brass as used in professional kitchen
- Solid smooth-surface cast iron pan supports

Cooking zones

- 1 multi-ring wok burner
18 MJ/h, suitable for pots up to max. ø 32 cm.
- 2 two-ring high output burners
14.4 MJ/h, suitable for pots up to max. ø 28 cm.
- 2 two-ring standard burners
7.2 MJ/h, suitable for pots up to max. ø 24 cm.

Handling

Control knobs with illuminated ring.
Integrated control panel.
One-handed operation.
Electric ignition.

Features

Three-part cast iron pan support with flat, continuous pot surface.
Brass burner rings.

Safety

Thermoelectric safety pilot.
Residual heat indication.
Operation indicator.

Planning notes

No intermediate shelf required.
Appliance can be snapped into the worktop from above.
Rear panel and wall trims must be heat-resistant and consist of a non-flammable material.
Installation in a 90 cm wide lower cabinet is required.
A minimum lateral clearance of at least 300 mm from adjacent heat-sensitive furniture or contact surfaces must be observed or thermal insulation fitted.
With a total connected load of more than 39.6 MJ/h local regulations concerning room ventilation, room size and combination of extraction or recirculation hoods must be observed.
Minimum clearance between gas cooktop(s) with more than 39.6 MJ/h and ventilation hood is 70 cm.
For details on this appliance, please refer to installation manual.
Appliance weight: approx. 31 kg.

Connection

Total connected load gas 61.2 MJ/h.
Total connected load electric 10.0 W.
Connecting cable 1.5 m with plug.

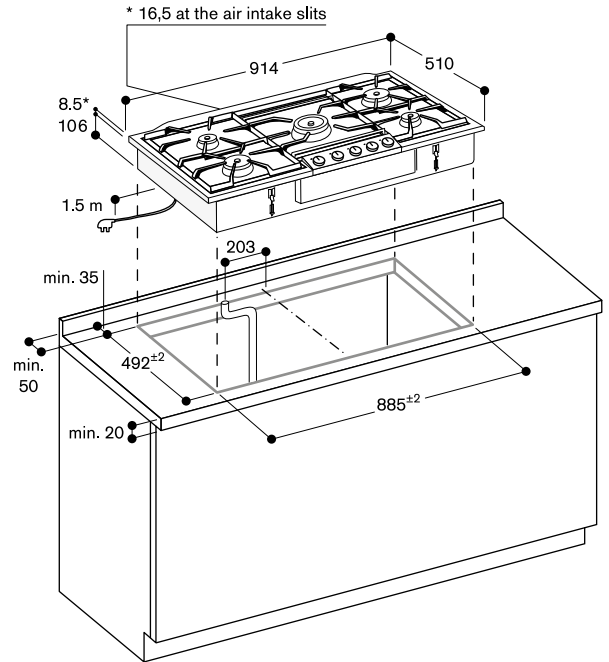

Minimum distance from the appliance cut-out to the side wall 300 mm.

Gas connection

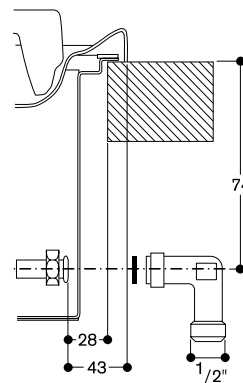



▲ Commercial exclusive model

CG 261 210 AU

Stainless steel
Width 60 cm
Natural gas 36.85 MJ/h
Up to 9.75kW on 4 burners

Included in the price

1 cross support for espresso
1 wok attachment ring

Special accessories

WP 400 001

Wok pan made of multiple-layer material
With round bottom and handle, ø36 cm, 6 litres, height 10 cm.

Gas cooktop 200 series

CG 261

- Mechanical power level regulation for 9 power levels, with exact setting and reproduction of flame size
- 15 MJ/h wok burner with burners
- Diamond-shaped arrangement

Cooking zones

1 multi-ring wok burner 15 MJ/h.
1 high output burner 11 MJ/h, suitable for pots up to max. ø 26 cm.
1 standard burner 6.85 MJ/h, suitable for pots up to max. ø 20 cm.
1 economy burner 4 MJ/h, suitable for pots up to max. ø 16 cm.

Handling

Control knobs with cooking zone and output level markings for 9 levels.
One-handed operation.
Electric ignition.

Features

Two-part cast iron pan support with continuous pot surface.
Enamelled burner cover.

Safety

Thermoelectric safety pilot.

Planning notes

The cooktop can be surface-mounted.
Special nozzles can be ordered as spare parts.
Installation in a 56 cm standard niche.
Air intake from above.
Intermediate shelf is recommended.
Allow for a gas connection when planning drawer depth.
Appliance must be fixed from underneath.
A minimum clearance of at least 100 mm from adjacent heat-sensitive furniture or contact surfaces must be observed or thermal insulation fitted.
Appliance weight: approx. 18 kg.
Minimum clearance between gas cooktop(s) with more than 39.6 MJ/h and ventilation hood is 70 cm.
For details on this appliance, please refer to installation manual.

Connection

Total connected load gas 36.85 MJ/h.
Connecting cable 1.0 m without plug.

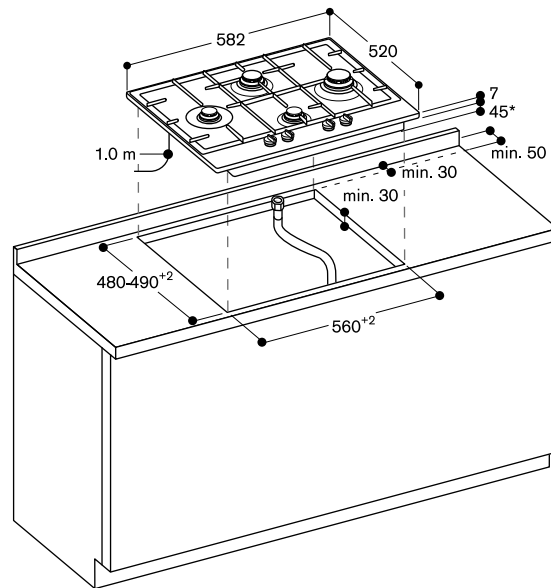

* 56 mm in the area of the gas connection at the back right



CX 482 100

Frameless
Width 80 cm

Included in the price

- 1 Cooking sensor for temperature regulation

Special accessories

CA 060 300

Cooking sensor for temperature regulation within pots
For flex induction cooktop.

GN 232 110

Teppan Yaki plate made of multi ply material,
GN 1/1
For full surface induction cooktops.

Full surface induction cooktop 400 series

CX 482

- One single large cooking surface
- Free positioning of cookware
- All sizes and formats of cookware can be used
- TFT touch display for an intuitive control of all functions
- Cooking sensor function for temperature control in pots
- Professional cooking functions
- Max. power output for big cookware of up to 5.5 kW
- Frameless for flush mounting

Cooking zones

One unique cooking surface of 2750 cm².
Up to 5 items of cookware can be placed simultaneously on the cooktop.

Handling

Easy to use colour graphic TFT touch display with use indications.
Electronic power control in 17 output levels.

Features

Cooking sensor function.
Professional cooking function.
Dynamic cooking function.
Teppan Yaki function.
Booster function for pots.
Booster function for pans.
Keep warm function.
Individual pot detection.
Cooking timer for each cooking position.
Stopwatch.
Short-term timer.
Information key with use indicators.
Power management.

Home network integration for digital services (Home Connect) either via cable connection LAN (recommended) or wireless via WiFi. The use of the Home Connect functionality is not yet available in Australia. For further information please check: home-connect.com

Safety

Main switch.
Residual heat indication.
Child lock.
Safety shut-off.
Pause function.

Planning notes

Operates with magnetic (induction) iron pots and pans only. For an optimal heat distribution, the use of sandwich bottom cookware is recommended. The wok pan WP 400 001 cannot be used with this appliance. Installation is possible in worktops made of stone, synthetics or solid wood. Heat resistance and watertight sealing of the cut edges must be observed. Concerning other materials please consult the worktop manufacturer.

The bearing capacity and stability, in the case of thin worktops in particular, must be supported using suitable substructures. Take into account the appliance weight and additional loads. The groove must be continuous and even, so that uniform placing of the appliance on the gasket is ensured. Do not use discontinuous lining. Intermediate shelf is recommended. Appliance must be fixed from underneath. Joint width may vary due to dimensional tolerances of the glass ceramic cooktop and the worktop cut-out. Appliance weight: approx. 27 kg.

Please read the installation details regarding air ducting on page 100.

Connection

Total connected load 7.4 kW.
Connecting cable 1.5 m without plug.

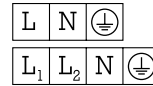

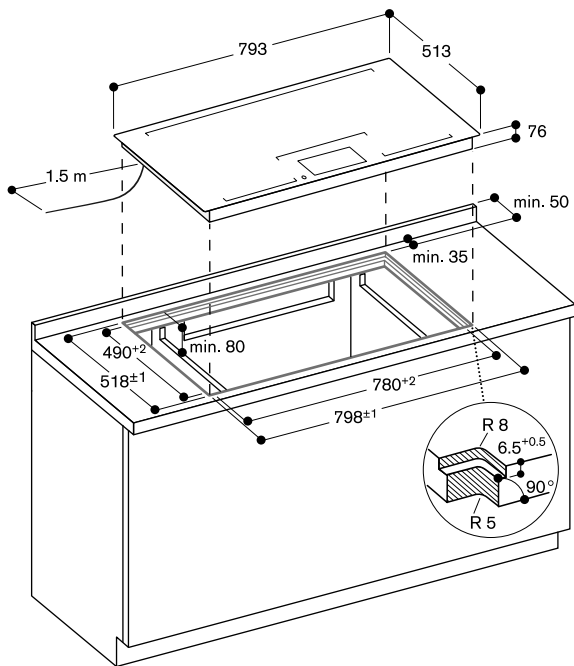

View from above

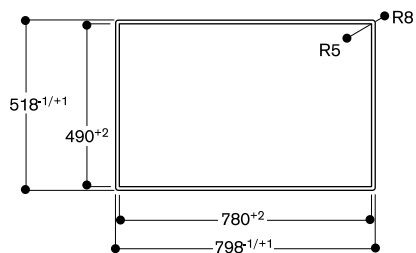

Longitudinal section

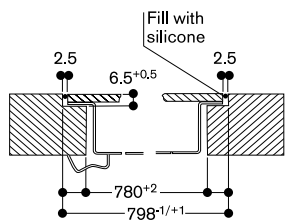

Cross-section

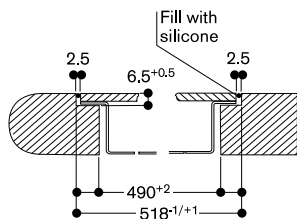



CX 482 110

Stainless steel frame
Width 80 cm

Included in the price

1 Cooking sensor for temperature regulation

Installation accessories

VA 420 000

Connection strip for combination with other Vario appliances of the 400 series for flush mounting

VA 420 001

Connection strip for combination with other Vario appliances of the 400 series for flush mounting with appliance cover/filler strip

VA 420 010

Connection strip for combination with other Vario appliances of the 400 series for surface mounting

VA 420 011

Connection strip for combination with other Vario appliances of the 400 series for surface mounting with appliance cover/filler strip

VA 450 800

Stainless steel filler strip 80 cm
Necessary accessory for combination of several Vario appliances of the 400 series with at least one appliance cover to compensate the appliance depth.

Special accessories

CA 060 300

Cooking sensor for temperature regulation within pots
For flex induction cooktop.

GN 232 110

Teppan Yaki plate made of multi ply material,
GN 1/1
For full surface induction cooktops.

Full surface induction cooktop 400 series

CX 482

- One single large cooking surface
- Free positioning of cookware
- All sizes and formats of cookware can be used
- TFT touch display for an intuitive control of all functions
- Cooking sensor function for temperature control in pots
- Professional cooking functions
- Max. power output for big cookware of up to 5.5 kW
- Precision crafted 3 mm stainless steel
- For surface mounting with a visible edge or for flush mounting
- Can be combined perfectly with other Vario appliances of the 400 series

Cooking zones

One unique cooking surface of 2750 cm².

Up to 5 items of cookware can be placed simultaneously on the cooktop.

Handling

Easy to use colour graphic TFT touch display with use indications.

Electronic power control in 17 output levels.

Features

Cooking sensor function.

Professional cooking function.

Dynamic cooking function.

Teppan Yaki function.

Booster function for pots.

Booster function for pans.

Keep warm function.

Individual pot detection.

Cooking timer for each cooking position.

Stopwatch.

Short-term timer.

Information key with use indicators.

Power management.

Home network integration for digital services (Home Connect) either via cable connection LAN (recommended) or wireless via WiFi. The use of the Home Connect functionality is not yet available in Australia. For further information please check:
home-connect.com

Safety

Main switch.

Residual heat indication.

Child lock.

Safety shut-off.

Pause function.

Planning notes

Depending on the type of installation (surface-mounted or flush-mounted), the specific definition of the cut-out must be observed.

If combining several appliances with at least one appliance cover, the filler strip VA 450 is required to compensate for the depth of the appliance without the appliance cover.

If combining several Vario appliances of the 400 series, a connection strip VA 420 must be placed between the appliances. Depending on the type of installation, the corresponding connection strip must be provided. In the cut-out, the installation system requires the side edge to be at least 10 mm for surface mounting and at least 13 mm for flush mounting. Ensure a continuous cut surface of 90°.

The bearing capacity and stability, in the case of thin worktops in particular, must be supported using suitable substructures. Take into account the appliance weight and additional loads. Additional instructions for flush mounting:

Installation is possible in worktops made of stone, synthetics or solid wood. Heat resistance and watertight sealing of the cut edges must be observed. Concerning other materials please consult the worktop manufacturer. The groove must be continuous and even, so that uniform placing of the appliance on the gasket is ensured. Do not use discontinuous lining. The joint width may vary due to size tolerances of the combinations and of the worktop cut-out.

Please read additional planning notes on page 72 – 77.

If installing several appliances in individual cut-outs allow for a division bar of minimum 50 mm between the individual cut-outs.

Operates with magnetic (induction) iron pots and pans only. For an optimal heat distribution, the use of sandwich bottom cookware is recommended. The wok pan WP 400 001 cannot be used with this appliance. Intermediate shelf is recommended. Appliance can be snapped into the worktop from above.
Appliance weight: approx. 27 kg.

Please read the installation details regarding air ducting on page 100.

Connection

Total connected load 7.4 kW.

Connecting cable 1.5 m without plug.

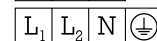

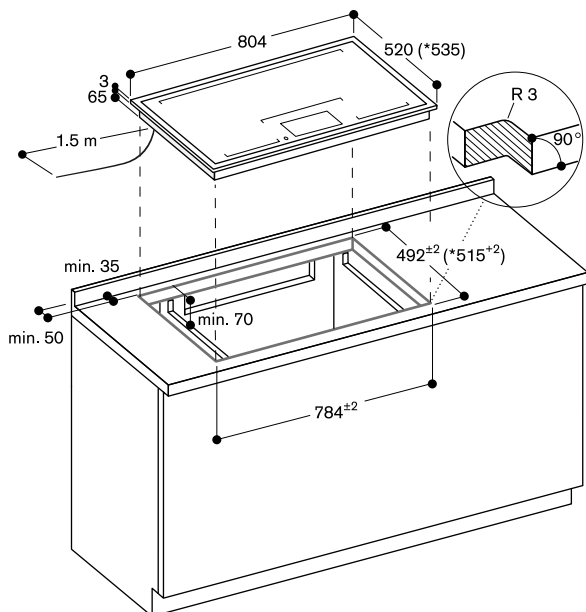

* with filler strip
See separate planning notes.

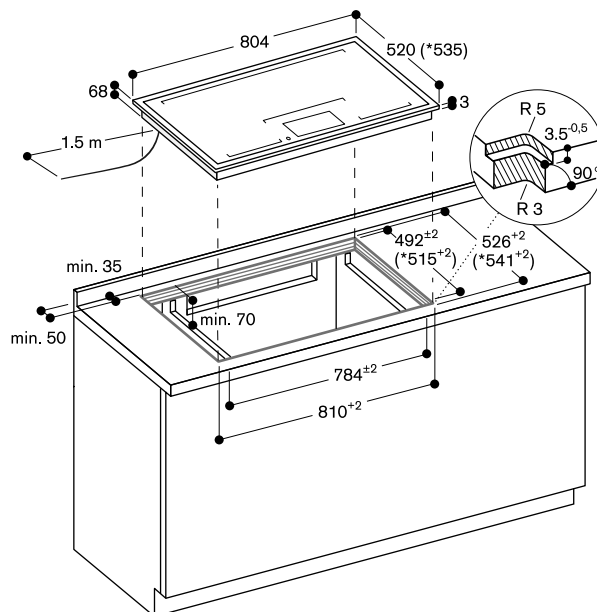

* with filler strip
See separate planning notes.

View from above

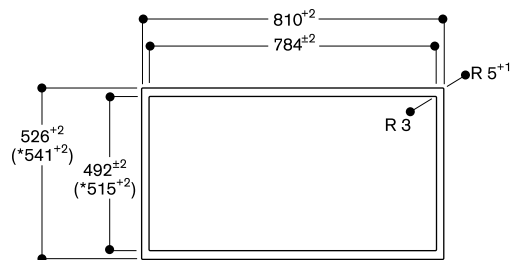

* with filler strip.

Longitudinal section

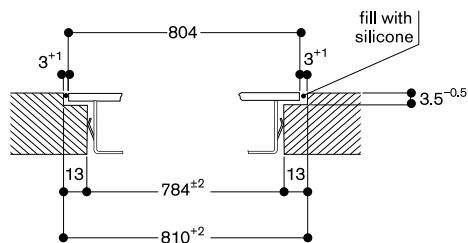

Cross-section

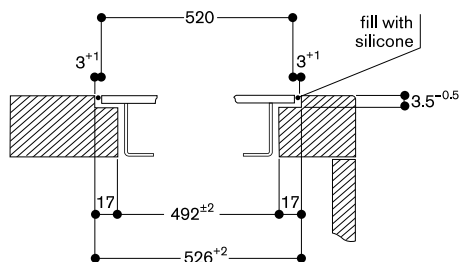

When installing with appliance cover or filler strip, pay attention to the deeper cut-out and the front and rear groove width.



CI 292 110

Stainless steel frame
Width 90 cm

Special accessories

CA 051 300

Teppan Yaki made of multi ply material
For flex induction cooktop.

CA 052 300

Griddle plate in cast aluminium
Non-stick.
For flex induction cooktop.

CA 060 300

Cooking sensor for temperature
regulation within pots.
For flex induction cooktop.

CA 230 100

Black magnetic knob for induction
cooktop 200 series.

GP 900 003

Stainless steel frying sensor pan
Non-stick coating, for ø21 cm cooking
zone.

GP 900 004

Stainless steel frying sensor pan
Non-stick coating, for ø28 cm cooking
zone.

Flex induction cooktop

CI 292

- Sturdy stainless steel frame
- Flex function for combining the rectangular cooking areas
- Free positioning of cookware inside combined cooking areas
- Professional cooking function for splitting the cooktop into 3 predefined heat areas
- Cooking sensor function for temperature control in pots
- Frying sensor function for temperature control in pans
- Large cooking zone for pots up to ø32 cm
- Twist-Pad control with removable magnetic knob
- Easy control of all functions with bicoloured display

Cooking zones

2 flex induction cooking areas
19x23 cm (2200 W, with booster
3700 W), linked together 38x23 cm
(3300 W, with booster 3700 W).
2 flex induction cooking areas
19x23 cm (2200 W, with booster
3700 W), linked together 38x23 cm
(3300 W, with booster 3700 W).
1 induction cooking zone ø21 cm
(2200 W, with booster 3700 W),
automatically switches to ø26 cm
(2600 W, with booster 3700 W) and
to ø32 cm (3300 W, with booster
3700 W).

Handling

Twist-Pad control with removable
magnetic knob.
User friendly control with bicoloured
display (white / orange).
Cooking zone, and cooking area
marking.
Electronic power control in 17 output
levels.

Features

Flex function for rectangular cooking
areas.
Professional cooking function.
Cooking sensor function (in use with
cooking sensor CA060300).
Frying sensor function.
Booster function for pots.
Booster function for pans.
Keep warm function.
Stopwatch.
Cooking timer for up to 99 minutes.
Short-term timer.
Options menu.
Power management.

Safety

Main switch.
Operation indicator.
Pot detection.
2-stage residual heat indication.
Child lock.
Safety shut-off.

Planning notes

Operates with magnetic (induction)
iron pots and pans only. For an optimal
heat distribution, the use of sandwich
bottom cookware is recommended.
The wok pan WP 400 001 cannot be
used with this appliance.
Immersion depth 55 mm.
Intermediate shelf is recommended.

Appliance must be fixed from
underneath.
Cooktop clamping range: 20 – 40 mm.
Appliance weight: approx. 22 kg.

Please read additional planning notes
on page 100.

Connection

Total connected load 11.1 kW.
Power requirements
220 – 240 V / 50 – 60 Hz.
Connecting cable 1.5 m without plug.

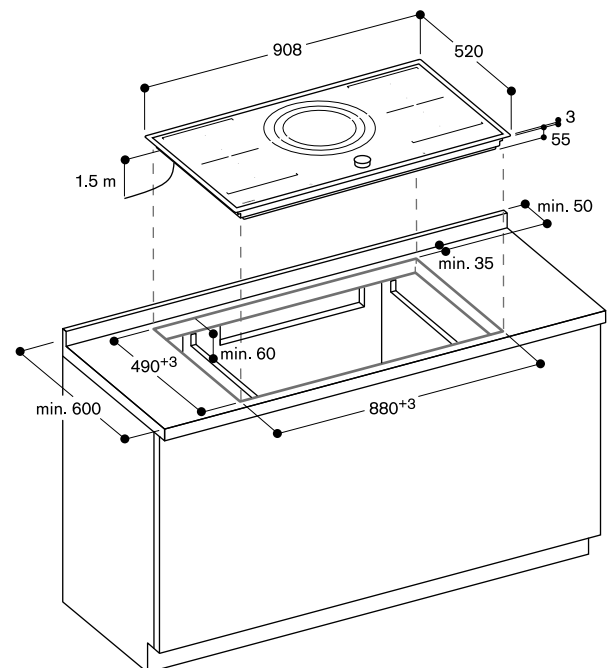
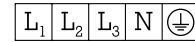
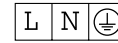



Installation notes for induction cooktops

Applies to CX 482, CI 292, VI 462/422/414, VI 262/232.

Intake air ducting

Induction cooktops have a cooling fan to protect the appliance's electronics from overheating. In the case of insufficient air circulation in the cabinet, the appliance's output will be reduced to prevent electronic damage.

A Air duct behind a cabinet or built-in oven

An open cross-section of a minimum of 20 mm is needed across the full width and full height of the cabinet. Cabinets with a closed bottom also need a respective cross-section in the air duct area.

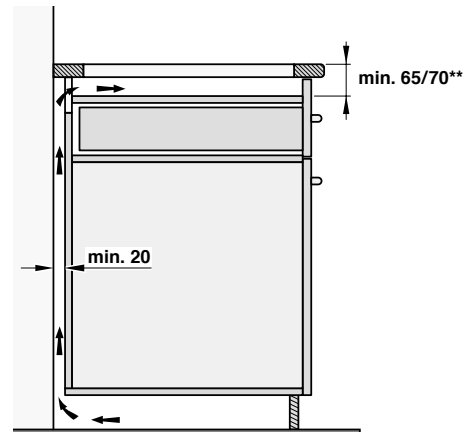

B Intake through the cabinet's back wall

In the cabinet's back wall, plan a recess of at least 45 mm in height from the worktop's bottom edge.

The minimum width is

- 300 mm for a 30 cm induction cooktop
- 350 mm for a 40 cm induction cooktop
- 550 mm for a Vario cooktop or a 60 cm to 80 cm induction cooktop
- 820 mm for a 90 cm induction cooktop

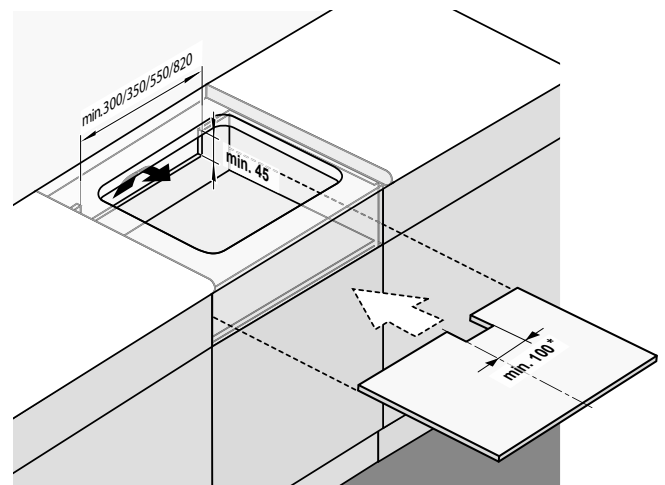

Intermediate shelf

The use of an intermediate shelf is recommended for cooktops with 90 cm width.

Width of cut-out at least

- 100 mm for a 60 to 80 cm induction cooktop

* does not apply to 90 cm cooktops

** min. 65 mm for cooktops with frame as well as VI 462 for surface mounting and min. 70 mm for cooktops without frame, for CX 482 with frame as well as for VI 462 for flush mounting.

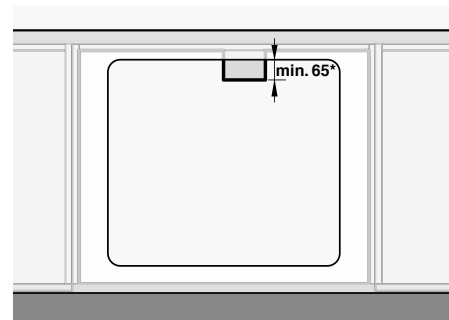

Combination with other appliances

Installation above dishwasher or washing machine is not permitted.

Combination with AL 400

In addition to the measures mentioned above, the following unobstructed cross sections must be planned between the cabinet and the AL 400 to allow for proper intake and exhaust air circulation for the induction cooktop.

A In front of the air duct

20 mm distance between the back side of drawers, an oven or the cabinet's interior wall.

B Adjacent to the air duct

The resulting gap between the air duct and the cabinet's side wall needs to remain open.

C At the housing's rear edge

The resulting cross section between the housing and the wall, as well as between the housing and the floor, must remain open.

Accessories and special accessories for cooktops

GN 232 110

Teppan Yaki plate made of multi ply material,
GN 1/1
For full surface induction cooktop.



CA 051 300

Teppan Yaki plate made of multi ply material
For flex induction cooktops.



CA 052 300

Griddle plate in cast aluminium
Non-stick.
For flex induction cooktops.



GP 900 003

Stainless steel frying sensor pan
Non-stick coating, ø 21 cm.



GP 900 004

Stainless steel frying sensor pan
Non-stick coating, ø 28 cm.



WP 400 001

Wok pan made of multiple-layer material
With round bottom and handle,
ø 36 cm, 6 litres, height 10 cm.



WZ 400 001

Wok attachment for wok pan



CA 060 300

Cooking sensor for temperature regulation within pots.



CA 230 100

Black magnetic knob for induction cooktop 200 series.
Stainless steel knob with black coating.



VA 420 000

Connection strip for combination with other Vario appliances of the 400 series for flush mounting



VA 420 001

Connection strip for combination with other Vario appliances of the 400 series for flush mounting with appliance cover/filler strip



VA 420 010

Connection strip for combination with other Vario appliances of the 400 series for surface mounting



VA 420 011

Connection strip for combination with other Vario appliances of the 400 series for surface mounting with appliance cover/filler strip



VA 450 800

Stainless steel filler strip 80 cm
Necessary accessory for combination of several Vario appliances of the 400 series with at least one appliance cover to compensate the appliance depth.













The ventilation appliances

Checklist for the modular ventilation appliances 400 and 200 series	104
Planning notes	105
Telescopic table ventilation 400 series	106
Recommended configurations for table ventilation	108
Vario downdraft ventilation 400 series	110
Recommended configurations for vario downdraft ventilation	114
Vario downdraft ventilations 200 series	116
Planning examples with the downdraft ventilation 200 series	118
Remote fan units	120
Island hoods 200 series	124
Wall mounted hoods 200 series	126
Slide out rangehoods 200 series	128
Integrated rangehoods 200 series	130
Accessories special accessories	132

Checklist for the modular ventilation appliances 400 and 200 series

Configurations maximum extraction values

	Air extraction		Air recirculation	
				
Telescopic table ventilation 400 series	AR 401 142	AR 403 122	AR 413 122	
AL 400 191	770 m³/h	750 m³/h	660 m³/h	
AL 400 121	840 m³/h	820 m³/h	700 m³/h	
				
Vario downdraft ventilation 400 series	AR 401 142	AR 403 122	AR 413 122	AR 410 110
VL 414 111	650 m³/h	630 m³/h	640 m³/h	560 m³/h
				
Vario downdraft ventilation 200 series	AR 401 142	AR 403 122	AR 413 122	AR 410 110
VL 200 120	720 m³/h	750 m³/h	670 m³/h	600 m³/h

Please see pages 120 – 123 for detailed fan unit specifications.

The external remote fan units of the 400 and 200 series have a network cable that is used to connect the motorless appliances of the 400 and 200 series.

Up to two remote fan units can be connected (e.g. with ceiling ventilation), whereby an additional network cable is connected from one remote fan unit to the other remote fan unit.

Other control options

It is possible on request to connect the signal via a zero potential contact to a ventilation appliance at the site so that this appliance can respond accordingly to activity on the part of Gaggenau's 400 and 200 series ventilation appliances.

The respective ventilation planner is then responsible for the effective operation of the entire ventilation system.

The guarantee of electrical function is maintained as long as the respective specifications are observed.

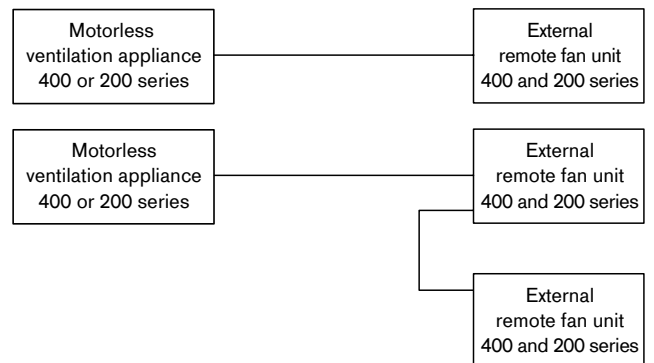

General planning notes

The aim of good ventilation system planning is to extract cooking vapours out of the kitchen area as completely and quickly as possible. To help you plan and install your system correctly, here are a few important notes on system planning from our ventilation experts.

The planning of a ventilation system is significantly determined by the air requirement and air output. The air requirement must be contrasted with the corresponding air output that a ventilation appliance can produce, while taking account of the influence of all the ventilation components involved.

Air requirement needed:

Please observe the local applicable building regulations when configuring ventilation solutions. The air output of a complete ventilation system must be designed according to the air requirement needed. For this, the size of the kitchen and a corresponding air change rate for the volume of space are often used as the basis for planning. We recommend this method only if the distance between the ventilation system and the cooktop is greater than 1.20 m, that is to say, for ceiling ventilation.

- For air extraction operation, the air requirement for the air exchange rate is calculated using a factor of 10.
- However, the calculation is made using a factor of 12 in kitchens where special cooking appliances such as the electric grill, Teppan Yaki or wok are used.
- For air recirculation, the air requirement for the air exchange rate is generally calculated using a factor of 12.

If the distance between the ventilation system and the cooktop is less than 1.20 metres, the factors listed below must be taken into account to ensure that most of the cooking vapours are trapped as soon as they rise from the cooktop:

- **The size and architecture of the kitchen:** As the size of the room increases, the movements of air in the room also increase and, as a result, the air requirement becomes greater.
- **The cooking appliances:** The choice of cooktop is the decisive influencing factor. Every cooktop produces different types and amounts of cooking vapours. The wider the cooktop, the higher the output of the ventilation system should be. Above all, the ventilation system must have a sufficient reserve capacity, if special Vario cooking appliances, such as a Teppan Yaki, wok or electric grill, are to be installed, because such appliances can be expected to produce a higher amount of cooking vapours. We therefore also recommend that these special cooking appliances are installed, if possible, in the centre of the cooktop configuration and not at the edge.
- **The type of ventilation system:** Every type of ventilation system has particular characteristics which influence the air requirement needed. Ventilation systems, such as downdraft ventilation and table ventilation, are characterised by extracting vapours directly from the cooktop. As they rise up, the cooking vapours can therefore not spread as far in the ambient air. In this case, the air output required is usually less than for those types of ventilation system that are 80 cm or further away from the cooktop.
- **The operation mode:** All Gaggenau ventilation systems can be operated both in exhaust air mode and air recirculation mode. It should be noted that, in air recirculation mode, the additional activated charcoal air filter leads to a reduction in air output in comparison to exhaust air mode. The larger the surface of the activated charcoal air filter, the more the ventilation system bears comparison in its extraction and noise behaviour with an exhaust air solution. In air extraction mode, the actual air output depends not only on the fan output, but also significantly on the duct system.

Important influencing factors on the air output:

- The fans: Gaggenau ventilation systems are equipped with particularly powerful fans, or they can be combined with correspondingly powerful remote fan units for exhaust air or air recirculation mode. These fans are also very pressure-stable. They overcome possible pressure losses caused by a ducting system and work highly effectively at a low noise level.
- Ducting and installation: To achieve optimum results, the following points should be observed during installation:
 1. Install duct bends with a minimum clearance of 30 cm from the exhaust air opening.
 2. Avoid reductions in cross sections.
 3. For duct bends, use bends that are as wide as possible.
 4. Only install ducts that have a smooth and flat inner surface.
 5. Use exhaust air pipes with a diameter of at least 125 mm.
 6. Pay attention to the use of a short ducting paths as possible.
 7. Fit wall outlets that have wide fins, wide-meshed grills and a low back-pressure.
 8. Ensure sufficient supply air.



AL 400 121

Stainless steel
Width 120 cm
Air extraction / Air recirculation
Motorless

AL 400 191

Stainless steel
Width 90 cm
Air extraction / Air recirculation
Motorless

Necessary installation accessories

AD 754 045

Connection piece for 2 aluflex pipes
DN 150 round

Fitting AL 400, front or back side.

AD 854 043

Connecting piece for 2 flat ducts
DN 150

Fitting AL 400, bottom side.

AD 854 045

Connecting piece for 2 flat ducts
DN 150

Fitting AL 400, front or back side.

Installation accessories

AA 010 410

Air exhaust grill air recirculation
Stainless steel-coloured, 90 cm,
including installation fittings, height
adjustable.

AA 409 401

Furniture support for table ventilation
AL 400 90 cm
Can be combined with table ventilation
AL 400.

Recommended as bearer for the
worktop, instead of a cabinet frame.

AA 409 431

Furniture support for table ventilation
AL 400 120 cm
Can be combined with table ventilation
AL 400.

Recommended as bearer for the
worktop, instead of a cabinet frame.

AD 704 048

Air collector box DN 150 round pipe
2x DN 150 round duct air intake.

For connecting 1 x AL 400 to
AR 403/AR 413

AD 704 049

Air collector box DN 150 flat duct
2 x DN 150 flat duct air intake.
To connect 1 x AL 400 to remote fan
AR 403/AR 413 bottom side.

Installation accessories for the air
recirculation ducts you will find on
pages 132 – 139.

Table ventilation 400 series

AL 400

- Extendable table ventilation, when not in use can be completely lowered into the worktop
- Can be combined perfectly with other Vario appliances of the 400 series
- Dimmable, neutral white surface LED light for ideal illumination of the whole cooktop
- Precision crafted 3 mm stainless steel
- For surface mounting with a visible edge or for flush mounting
- Motorless, can be combined with Gaggenau BLDC remote fan units

Output

Power levels depend on the remote fan unit, see page 104 – 105.

Features

3 electronically controlled power levels and 1 intensive mode.
Interval ventilation, 6 min.
Run-on function, 6 min.
Grease filter saturation indicator.
Cartridge-type filter, dishwasher-safe.
Neutral white surface LED light (3600 K), continuously dimmable.
Lamp output 4x5 W.
Illuminance 191 lx.
Spare covers for closing air outlets.
No connecting piece included.

Consumption data

Consumption data is referred to a configuration AL 400 121/AL 400 191 with the remote fan unit AR 401 142.
Energy consumption 45.1/49 kWh/year.
Sound level min. 44/49 dB / max. 45/61 dB normal mode.

Planning notes

Refer to the table on page 104 for the matching remote fan units for air recirculation or air extraction mode.
Secure the control unit to the side panel of the cabinet, not to the base of the cabinet or the kitchen floor.
Connection to the respective appliances via network cable.
AL 400 121 (AL 400 191)
For operation with 4 (3) Vario 200 series cooktops, 3 (2) Vario 400 series cooktops or a cooktop configuration of up to 120 cm (92 cm) wide.
Operation of Vario cooking appliances only possible without appliance cover.
Max. output of cooktops 18 kW.
In combination with the cooktop CI 290, installation in 60 cm deep worktops is possible.
Installation is possible in worktops made of stone, synthetics or solid wood. Heat resistance and watertight sealing of the cut edges must be observed. Concerning other materials please consult the worktop manufacturer.

The remaining surface of the worktop (min. 50 mm) between the cut-outs must be reinforced with a support. It is recommended to use furniture support AA 409 401/431.

Ovens that do not exceed the maximum allowed cabinet temperature can be combined with the table ventilation if built-in situation permits.

To avoid smoke when frying/grilling refer to the manuals of VR/VP.

When installing a ventilation hood with air extraction mode and a chimney-vented fireplace, the power supply line of the ventilation appliance needs a suitable safety switch.

Please read additional planning notes on page 107 – 109.

Connection

Total connected load 65 W
Connecting cable 1.7 m, with plug.
Network cable 1.2 m.

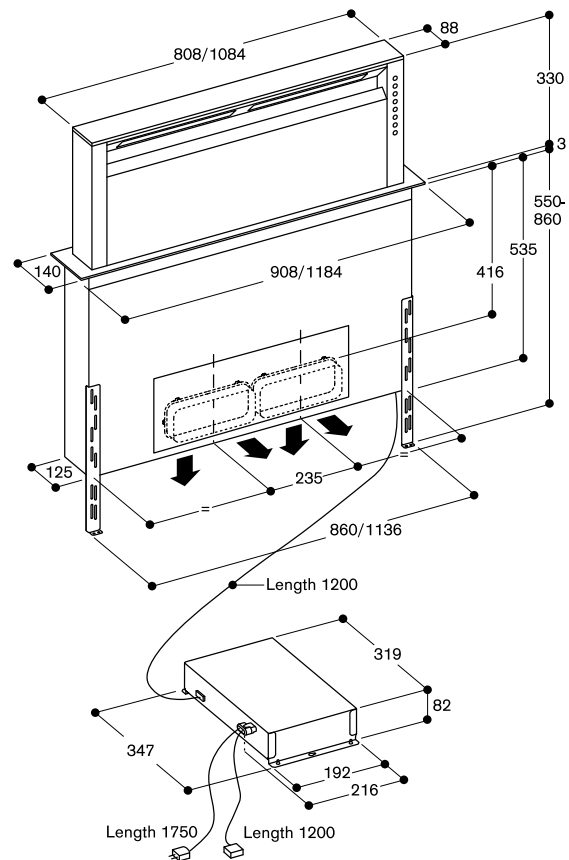

Pipe connection piece 2 x DN 150 front/rear
Flat duct using AD 854 045
Round duct using AD 754 045

Pipe connection piece 2 x DN 150 bottom
Flat duct using AD 854 043

AL 400 connection positions DN 150

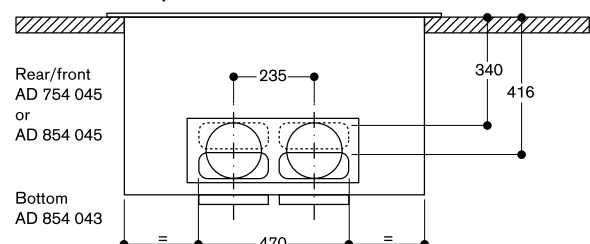

AA 010 410 air exhaust grille

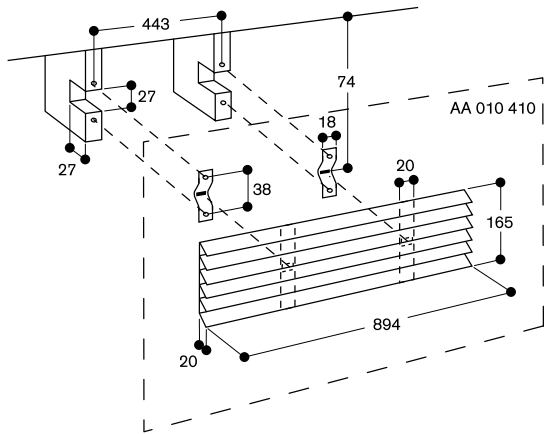

AD 754/854 045 and AD 854 043

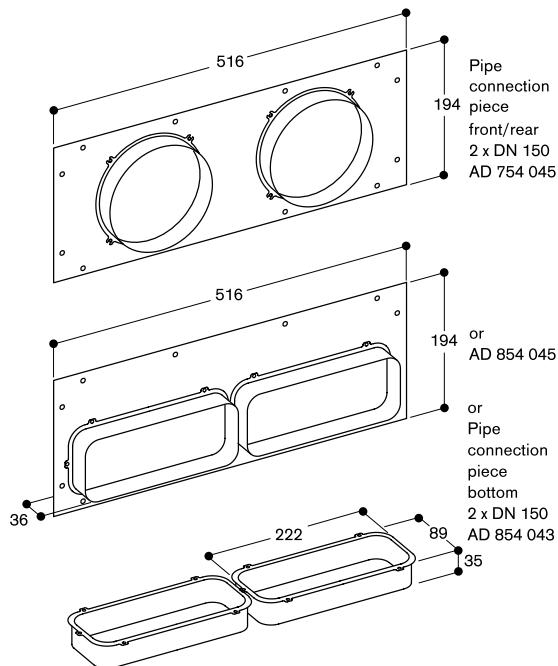

AA 409 401/431 furniture support

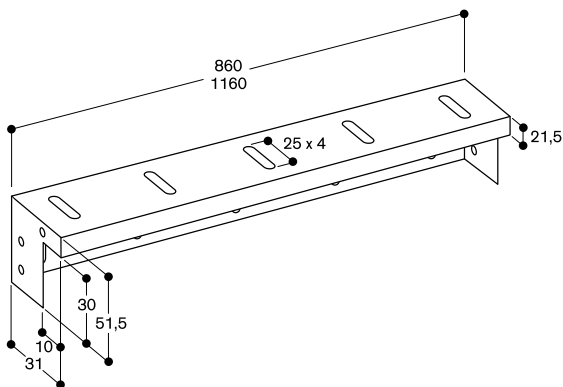

AL 400 installed flush

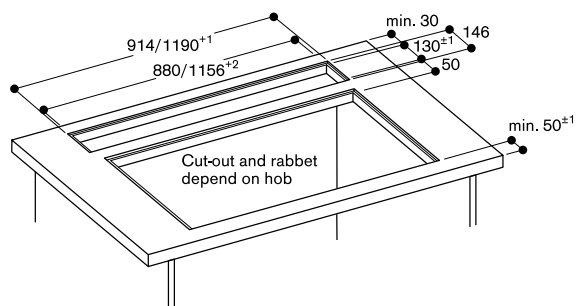

Longitudinal section

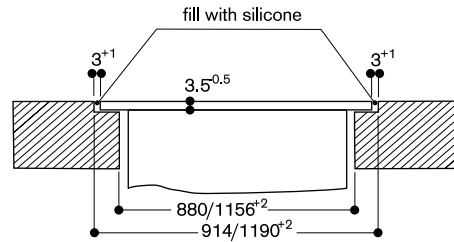

Cross-section

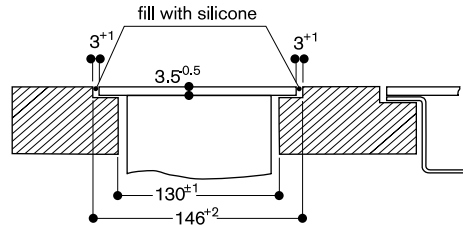

AL 400 cut-out flush-mounted

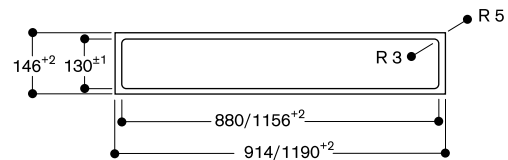

AL 400 cut-out for surface mounting

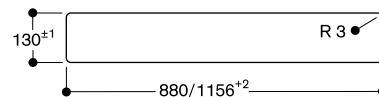

Cross-section of upper cabinet for AL 400 (without back wall) with AR 413; connection at the bottom

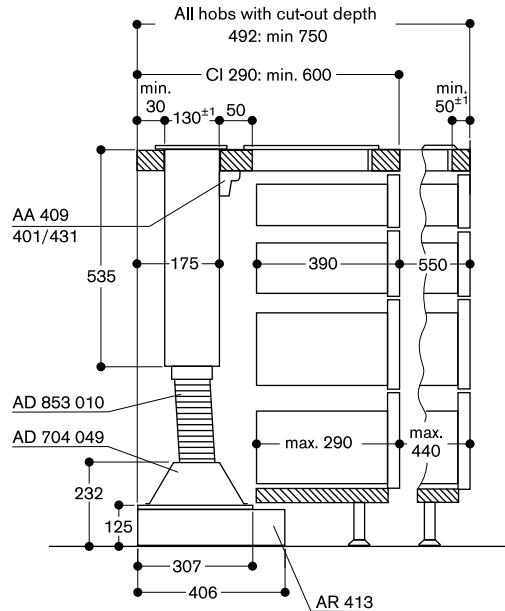

Recommended configurations for table ventilations 400 series and remote fan units 400 series

Good to know – for correct planning and installation

- The ducting can essentially be connected to the front, rear or below with the AL 400 table ventilation. The respective connecting pieces are available for this purpose.
- Plastic ducts can be used for installation behind a gas appliance. The maximum permitted performance of the cooktops is 18 kW.
- We recommend ducts with DN 150 for optimal air circulation.
- 2 flat ducts and 2 round ducts must be connected using a pipe connector.
- 2 bends (e.g. 90° horizontal with 90° vertical) require one flat duct pipe for connection, which can be shortened to the required length by cutting.
- It is equally important to ensure proper sealing of the ducting to avoid air leakages, for example with adhesive tape AD 990 090 (UV and heat resistant).
- If the AL 400 121 is installed in air recirculation mode and intensive cooking (e.g. Vario Teppan Yaki) is involved, we recommend to use a second remote fan unit AR 413 122 to support the vapour catch behaviour, see planning example 6.
- Vario cooktops with intensive vapour formation like Vario Teppan Yaki or Vario electric grill should be placed central in front of the ventilation appliance;
- in case of Vario electric grill air recirculation is not recommended.
- Secure the control unit to the side panel of the cabinet, not to the base of the cabinet or the kitchen floor.

Planning example 1

1 x AL 400 with AR 403 122 (air extraction) / AR 413 122 (air recirculation)

Connection to the front with flat duct or aluflex pipe, DN 150; cabinet installation

Combination

1 x AL 400 table ventilation combined with 1 x AR 403 122 / AR 413 122 remote fan unit

Good to know

- The air collector box can be screwed directly to the remote fan unit. The reducing piece supplied is not needed in this case.
- For optimum performance, the recirculated air requires sufficient space to escape (outflow surface area of at least 700 cm² for each remote fan unit).

List of accessories 1

- 1 x AD 754 045 (connection pieces for round duct, 2 x DN 150)
- 2 x AD 852 042 (Flat duct adapter round 90°)
- 1 x AD 704 049 (Air collector box DN 150 flat duct)
- 1 x AD 853 010 (Flat duct system flex pipe)
- 1 x AD 990 090 (adhesive tape for bonding the ducts)

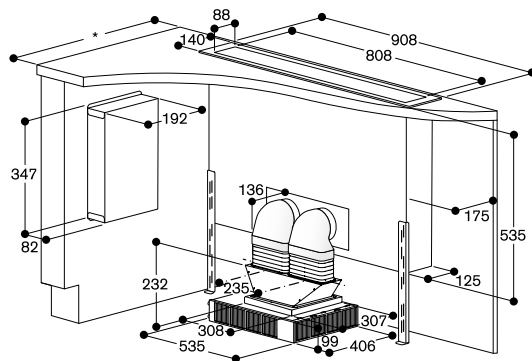

* All cooktops with cut-out depth 492: min. 750

Planning example 2

1 x AL 400 with AR 403 122 (air extraction) / AR 413 122 (air recirculation)

Connection downward with flex duct, DN 150, cabinet installation

Combination

1 AL 400 table ventilation combined with 1 x AR 403 122 / AR 413 122 remote fan unit

Good to know

- The air collector box can be screwed directly on the remote fan unit. The reducing piece supplied is not needed in this case.
- For optimum performance, the recirculated air requires sufficient space to escape (outflow surface area of at least 700 cm² for each remote fan unit).

List of accessories 1

- 1 x AD 854 043 (connecting pieces for flat duct downward, 2 x DN 150)
- 1 x AD 704 049 (air collector box for AL 400)
- 1 x AD 853 010 (Flat duct Flexduct, DN 150)
- 1 x AD 990 090 (Adhesive tape for bonding the ducts)

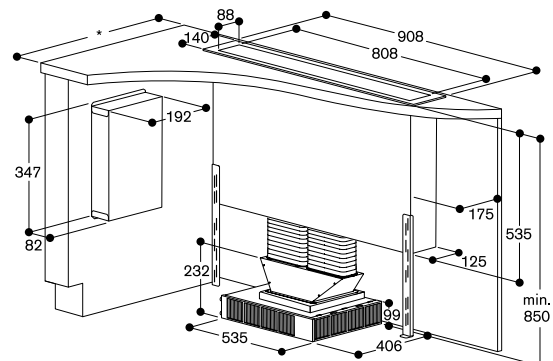

* All cooktops with cut-out depth 492: min. 750

List of accessories 2

- 1 x AD 754 045 (connecting pieces for round duct, 2 x DN 150)
- 2 x AD 751 010 (aluflex pipe round, DN 150)
- 1 x AD 704 048 (air collector box for AL 400)

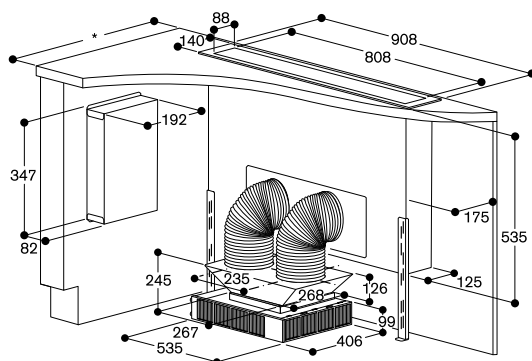

* All cooktops with cut-out depth 492: min. 750

Planning example 3
1 x AL 400 with AR 401 142

Connection downward with flat and round duct, DN 150; installation on outside wall

Combination

1 x AL 400 table ventilation combined with 1 x AR 401 142 remote fan unit

Good to know

- The AR 401 142 remote fan unit for installation on the outside wall is the ideal solution for compact air extraction.
- The ducting can be directed to outside via the cellar in this case. A minimum distance must simply be maintained for the air exhaust downwards on the AR 401 142 (100 cm). Distance ground to central line of the pipe: 60 cm.
- Local building regulations must be observed for the cellar breakout (especially with respect to the topic of fire safety).
- The ducting can of course also be implemented in the plinth area of the kitchen cabinets.

List of accessories 1

- 1 x AD 854 043 (connecting pieces for flat duct downwards, 2 x DN 150)
- 2 x AD 852 041 (flat duct transition round 90°)
- 2 x AD 751 010 (aluflex pipe round, DN 150); possibly additional ducts depending on the exhaust air ducting (aluflex or Naber round duct, DN 150)
- 1 x AD 704 048 (air collector box for AL 400)
- 1 x AD 702 052 (telescopic wall duct, DN 200)

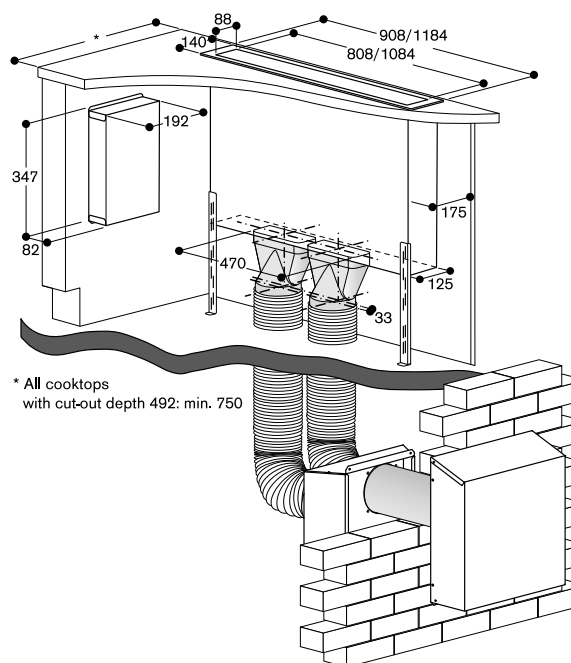
Planning example 4
1 x AL 400 121 with 2 x AR 413 122

Connection to the front with flat duct

Combination

1 AL 400 121 table ventilation combined with 2 x AR 413 122 remote fan unit

Good to know

- If the AL 400 121 is installed in air recirculation mode and intensive cooking (e.g. Vario Teppan Yaki) is involved, we recommend to use a second remote fan unit AR 413 122 to support the vapour catch behaviour
- For optimum performance, the recirculated air requires sufficient space to escape (outflow surface area of at least 700 cm² for each remote fan unit).

List of accessories 1

- 1 x AD 754 045 (connection pieces for round duct, 2 x DN 150)
- 2 x AD 852 042 (flat duct adapter round 90°)
- 1 x AD 852 010 (flat duct)
- 1 x AD 852 031 (flat duct bend 90° horizontal)
- 2 x AD 852 041 (flat duct adapter round, DN 150)
- 1 x AD 990 090 (adhesive tape for bonding the ducts)

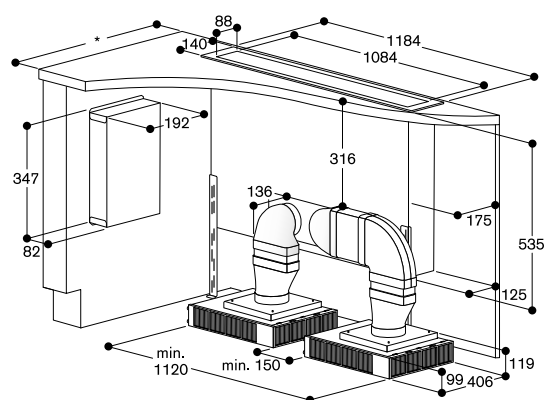



VL 414 111

Stainless steel
Width 11 cm
Air extraction / Air recirculation
Without motor and control knob

Necessary installation accessories**AA 490 111**

Stainless steel control knob

AD 724 042

Connection piece for round pipe
DN 150 For VL 414
For installation to left or right side of
VL additional adapter AD 724 041 is
necessary.

AD 724 041

Round duct connection additional
adapter for VL 414 on the side
Metal zinc coated
Necessary for installation to left or
right side of VL.

AD 854 046

Flat duct system with guidance fins
Connecting piece VL 414 for
DN 150 flat

Installation accessories**VA 420 000**

Connection strip for combination
with other Vario appliances of the
400 series for flush mounting

VA 420 001

Connection strip for combination
with other Vario appliances of the
400 series for flush mounting
with appliance cover/filler strip

VA 420 010

Connection strip for combination
with other Vario appliances of the
400 series for surface mounting

VA 420 011

Connection strip for combination
with other Vario appliances of the
400 series for surface mounting
with appliance cover/filler strip

VA 450 110

Stainless steel filler strip 11 cm
Necessary accessory for combination
of several Vario appliances of the
400 series with at least one appliance
cover to compensate the appliance
depth.

Special accessories**AA 414 010**

Ventilation moulding for VL 414 next to
gas appliance.

**Installation accessories for the air
recirculation ducts you will find on
pages 132 – 139.**

Vario downdraft ventilation 400 series**VL 414**

- Highly efficient ventilation system at the cooktop
- Flexible power distribution, precise extraction of cooking vapours only at the open ventilation elements
- Can be combined perfectly with other Vario appliances of the 400 series
- Precision crafted 3 mm stainless steel
- For surface mounting with a visible edge or for flush mounting
- Motorless, can be combined with Gaggenau BLDC remote fan units

Output

Power levels depend on the remote fan unit, see page 104 – 105.

Features

Manual opening of the ventilation element.
Closing element made of stainless steel, dishwasher-safe.
Metal grease filter, dishwasher-safe.
No connecting piece included.

Consumption data

Consumption data is referred to a configuration with the remote fan unit AR 403 122.
Energy consumption 42.7 kWh/year.
Sound level min. 56 dB / max. 68 dB normal mode.

Planning notes

Refer to the table on page 104 for the matching remote fan units for air recirculation or air extraction mode. Secure the control unit to the side panel of the cabinet, not to the base of the cabinet or the kitchen floor. For each VL one remote fan unit is recommended.
Maximum cooktop width between two VL: 60 cm.
Appliance can be snapped into the worktop from above. Additional fixing by clamps accessible from bottom up, clamping range 30-50 mm.
If installing with the appliance cover VA 440 or filler strip VA 450 take into account the additional space required for the depth.
If combining several appliances with at least one appliance cover, the filler strip VA 450 is required to compensate for the depth of the appliance without the appliance cover.
If combining several Vario appliances of the 400 series, a connection strip VA 420 must be placed between the appliances. Depending on the type of installation, the corresponding connection strip must be provided. In the cut-out, the installation system requires the side edge to be at least 10 mm for surface mounting and at least 13 mm for flush mounting. Ensure a continuous cut surface of 90°. The bearing capacity and stability, in the case of thin worktops in particular, must be supported using suitable substructures.

Take into account the appliance weight and additional loads.

Additional instructions for flush mounting:
Installation is possible in worktops made of stone, synthetics or solid wood. Heat resistance and watertight sealing of the cut edges must be observed. Concerning other materials please consult the worktop manufacturer. The groove must be continuous and even, so that uniform placing of the appliance on the gasket is ensured. Do not use discontinuous lining. The joint width may vary due to size tolerances of the combinations and of the worktop cut-out.
If installing several appliances in individual cut-outs allow for a division bar of minimum 50 mm between the individual cut-outs.
If operated next to gas appliances, the ventilation moulding AA 414 010 is recommended to ensure maximum performance of the cooktop. If installed next to gas appliances, flat ducts must not be used for the piping up to the fan unit. If installed next to VP 414, the flat duct must not be positioned underneath the VP 414.

Please read the installation details regarding air ducting on page 114 – 115.

Please read additional planning notes on page 72–77.

Connection

Connection cable 2.0 m between ventilation element VL 414 and control knob AA 490.

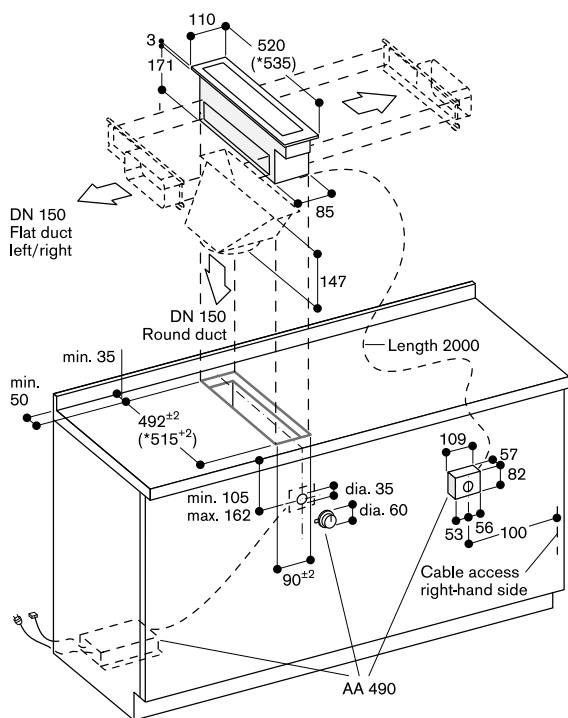

* with filler strip

- Flat duct pipe connection piece, left/right DN 150 with AD 854 046
- Round duct pipe connection piece, bottom DN 150 with AD 724 042
- Round duct pipe connection piece, left/right DN 150 with AD 724 042 + AD 724 041

See separate planning notes for
 - Positioning of control knob
 - Configuration for flexible power distribution

VL 414 with AD 724 042/041

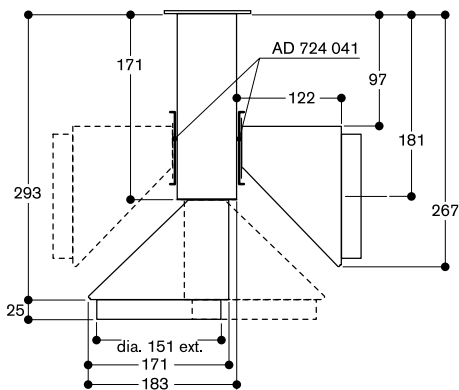

AD 854 046

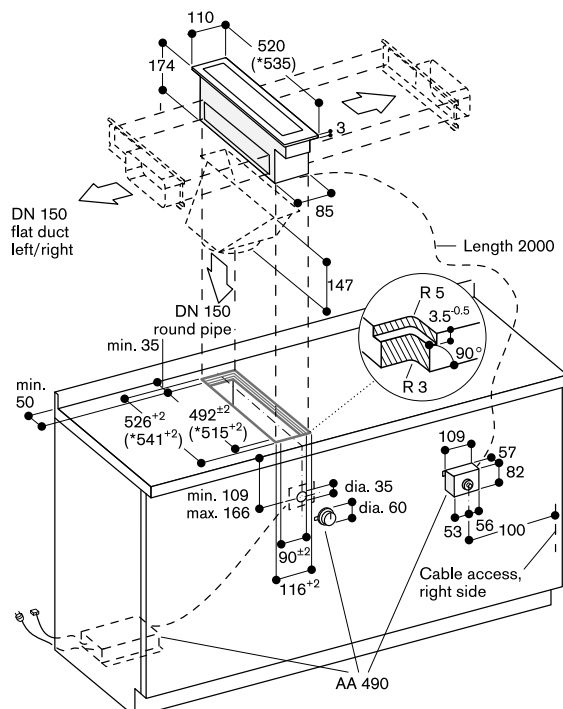
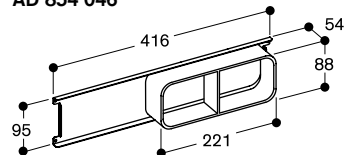

* with filler strip

- Flat duct pipe connection piece, left/right DN 150 with AD 854 046
- Round duct pipe connection piece, bottom DN 150 with AD 724 042
- Round duct pipe connection piece, left/right DN 150 with AD 724 042 + AD 724 041

See separate planning notes for
 - Positioning of control knob
 - Configuration for flexible power distribution

View from above

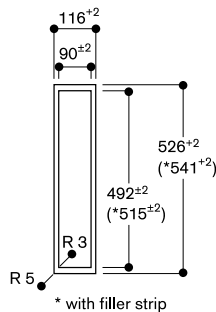

* with filler strip

Cross-section

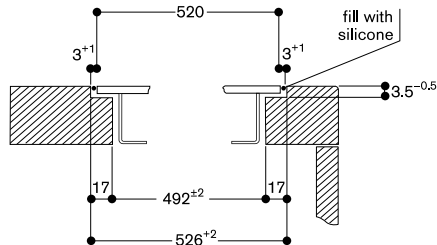

When installing with appliance cover or filler strip, pay attention to the deeper cut-out and the front and rear groove width.

Longitudinal section

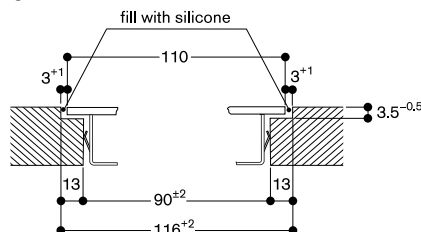



AA 490 111
Stainless steel

Vario control knob ventilation 400 series
AA 490

- Solid stainless steel control knob
- Can be combined perfectly with other Vario appliances of the 400 series
- Motorless, can be combined with Gaggenau BLDC remote fan units

Handling

Control knob with illuminated ring and output marking.

Features

3 electronically controlled power levels and 1 intensive mode.
Run-on function, 6 min.

Planning notes

The separate electronics housing is to be installed so that it is accessible.
Secure the control unit to the side panel of the cabinet, not to the base of the cabinet or the kitchen floor.

When installing a ventilation hood with air extraction mode and a chimney-vented fireplace, the power supply line of the ventilation appliance needs a suitable safety switch.

Connection

Total connected load 10W.
Connecting cable 1.8 m, with plug.

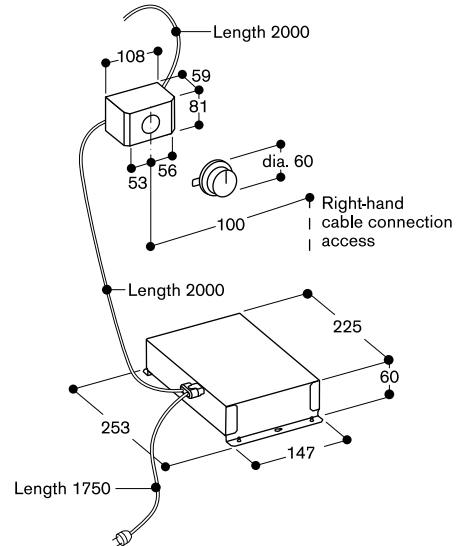



Recommended configurations of the Vario downdraft ventilation 400 series and remote fan units 400 series

Good to know – for correct planning and installation

- For depth measurements, take account of the depth of the furniture cavity and worktop overhangs of the kitchen furniture.
- With the Vario downdraft ventilation, the ducting can be connected on the right, left or downwards.
- If the system is installed next to a gas appliance, ducts made of plastic (e.g. the flat duct system) must not be used, because of heat generation. In such cases, we recommend the use of aluflex pipes of the downdraft ventilation, directed downwards (accessory AD 724 042).
- Please note that flat ducts cannot be installed on the right or left of the following appliances due to their depth: Vario Teppan Yaki, Vario electric grill. For these, we recommend connection either to the other side or in a downward direction.
- For optimum air circulation, we recommend ducts with DN 150.
- 2 flat or 2 round ducts must be connected with a pipe connector.
- To connect 2 duct bends together (e.g. a 90° horizontal duct bend and a 90° vertical duct bend), a piece of flat duct is required, which can be shortened to the required length by cutting it to size.
- It is also important that ducting is well sealed in order to prevent air leaks, e.g. by using the adhesive tape AD 990 090 (UV- and heat-resistant).
- Vario cooktops with intensive vapour formation like Vario Teppan Yaki or Vario electric grill should be placed centrally in the cooktop configuration. In case of Vario electric grill air recirculation is not recommended.
- Secure the control unit to the side panel of the cabinet, not to the base of the cabinet or the kitchen floor.

Planning example 1

1 x VL 414 with AR 413 122 (Air recirculation)

Flat duct with 2 x 90° duct bends or flat duct with 1 x 90° duct bend

Combination

1 x downdraft ventilation in combination with 1 x AR 413 122 remote fan unit.

Good to know

- The remote fan unit can be turned in all directions, depending on the desired direction for the exhaust air or filter removal.
- For optimum performance, the recirculated air requires sufficient space to escape (outflow surface area of at least 700 cm²). For this, we recommend the air exhaust grill AA 010 410.
- The connecting piece DN 150 is included with the remote fan unit.
- The recommended minimum distance between filter openings and cupboard wall if there is no ventilation grill directly in front: 15 cm.

List of accessories 1

- 1 x AD 854 046 (connecting piece for VL 414, DN 150)
- 1 x AD 852 031 (flat duct with horizontal 90° duct bend)
- 1 x AD 852 030 (flat duct with vertical 90° duct bend)
- 1 x AD 852 010 (flat duct)
- 1 x AD 852 041 (flat duct adapter round)
- 1 x AA 490 111 (Vario control knob)
- 1 x AD 990 090 (adhesive tape for sealing the ducts)

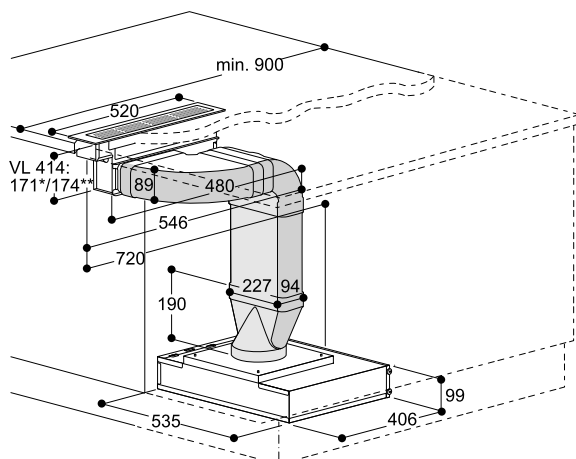

* surface mounting
** flush mounting

List of accessories 2

- 1 x AD 854 046 (connecting piece for VL 414, DN 150)
- 1 x AD 852 030 (flat duct with vertical 90° duct bend)
- 1 x AD 852 010 (flat duct)
- 1 x AD 852 041 (flat duct adapter round)
- 1 x AA 490 111 (Vario control knob)
- 1 x AD 990 090 (adhesive tape for sealing the ducts)

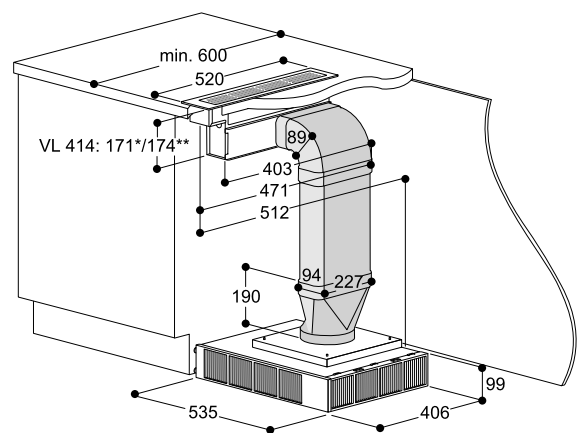

* surface mounting
** flush mounting

Planning example 2
1 x VL 414 with AR 403 122 (Air extraction)

Flat duct with 2 x 90° duct bends or flat duct with 1 x 90° duct bend

Combination

1 x downdraft ventilation in combination with 1 x AR 403 122 remote fan unit

Good to know

The connecting piece DN 150 is included with the remote fan unit.

List of accessories 1

- 1 x AD 854 046 (connecting piece for VL 414, DN 150)
- 1 x AD 852 031 (flat duct with horizontal 90° duct bend)
- 1 x AD 852 030 (flat duct with vertical 90° duct bend)
- 1 x AD 852 010 (flat duct)
- 1 x AD 852 041 (flat duct adapter round)
- 1 x AA 490 111 (Vario control knob)
- 1 x AD 990 090 (adhesive tape for sealing the ducts)

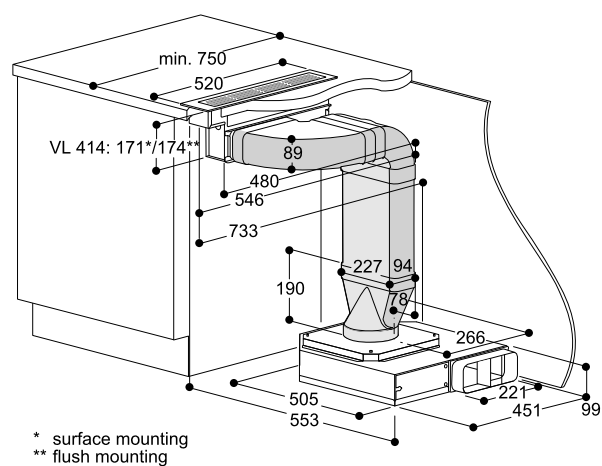
List of accessories 2

- 1 x AD 854 046 (connecting piece for VL 414, DN 150)
- 1 x AD 852 030 (flat duct with vertical 90° duct bend)
- 1 x AD 852 010 (flat duct)
- 1 x AD 852 041 (flat duct adapter round)
- 1 x AA 490 111 (Vario control knob)
- 1 x AD 990 090 (adhesive tape for sealing the ducts)

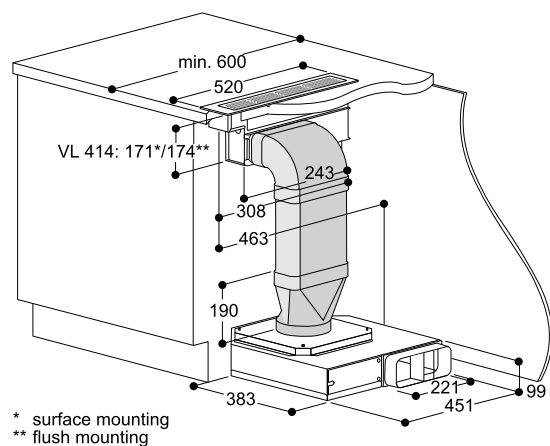
Planning example 3
1 x VL with AR 410 110 (Air recirculation)

Flat duct with 2 x 90° bends

Combination

1 x downdraft ventilation in combination with 1 x AR 410 110 remote fan unit

Good to know

The charcoal filter exchange is possible from both sides.

Allow accessibility to the charcoal filters in the lower cabinet for replacing the filter.

It is possible to position the remote fan unit direct on the floor or fix it with the retaining brackets with a cut-out in the furniture base.

For configuration 2 is depending on the depth of the island a second flat duct AD 852 010 needed.

 For optimum performance, the recirculated air requires sufficient space to escape (outflow surface area of at least 700 cm²).

List of accessories 1

- 1 x AD 854 046 (connecting piece for VL 414, DN150)
- 1 x AD 852 031 (flat duct with horizontal 90° duct bend)
- 1 x AD 852 030 (flat duct with vertical 90° duct bend)
- 1 x AD 852 010 (flat duct)
- 1 x AD 852 040 (flat duct connecting piece)
- 1 x AA 490 111 (Vario control knob)
- 1 x AD 990 090 (adhesive tape for sealing the ducts)

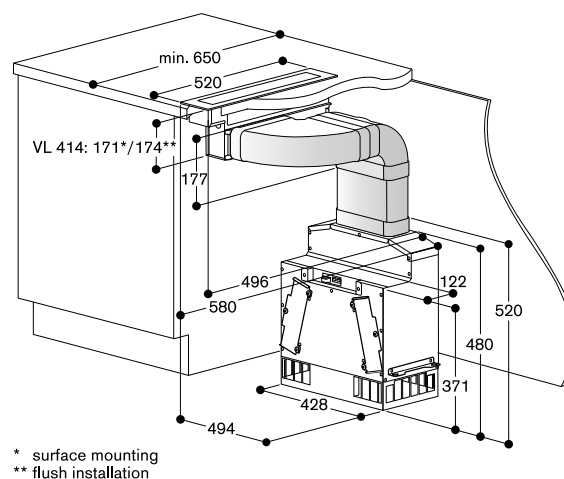
List of accessories 2

- 1 x AD 854 046 (connecting piece for VL 414, DN150)
- 1 x AD 852 031 (flat duct with horizontal 90° duct bend)
- 1 x AD 852 030 (flat duct with vertical 90° duct bend)
- 1 x AD 852 010 (flat duct)
- 1 x AD 852 040 (flat duct connecting piece)
- 1 x AA 490 111 (Vario control knob)
- 1 x AD 990 090 (adhesive tape for sealing the ducts)

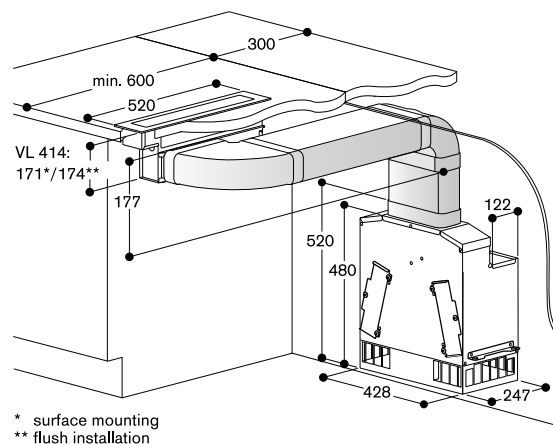



VL 200 120

Black control panel
Width 15 cm
Air extraction / Air recirculation
Motorless

Installation accessories

AD 410 040

Flexible connecting piece for VL200
DN 150 flat

AD 851 041

Connecting piece VL200 for extension
with flat duct DN 150 for extra deep
worktop

VV 200 010

Stainless steel connection strip for
combination with other Vario
appliances of the 200 series

VV 200 020

Black connection strip for combination
with other Vario appliances of the
200 series

Special accessories

LS 041 001

Ventilation moulding for VL 200 next to
gas appliance
Stainless steel

**Installation accessories for the air
recirculation ducts you will find on
pages 132 – 139.**

Vario downdraft ventilation 200 series

VL 200

- Can be combined with the cooktops of the Vario 200 series
- Highly efficient ventilation system at the cooktop integrated in the worktop
- Function for automatic, sensor-controlled power adjustment depending on the build-up of cooking vapours
- Minimal planning and easy installation
- Air extraction or air recirculation system

Output

Power levels depend on the remote fan unit, see page 104 – 105.

Features

Control knobs with illuminated ring.
3 electronically controlled power levels and 1 intensive mode.
Automatic function with sensor-controlled run-on function.
Large-scale metal grease filter with high grease absorption.
Grease filter, dishwasher-safe.
Grease filter and activated charcoal filter saturation indicator.
Airflow-optimised interior for efficient air circulation.
Interval ventilation, 6 min.
Enamelled ventilation grill, dishwasher-safe.
Air exhaust bend included in delivery.
Overflow 250 ml capacity.

Consumption data

Consumption data is referred to a configuration with the remote fan unit AR 403 122.
Energy consumption 39.7 kWh/year.
Sound level min. 58 dB / max. 73 dB normal mode.

Planning notes

Air recirculation mode in combination with remote fan unit with AR 410 110 or AR 413 122.
Air extraction in combination with remote fan unit AR 403 122 or AR 401 142 (outside motor).
Please refer to page 104, 118 – 119 for recommended configurations of downdraft ventilations and remote fan units and the needed ducting elements.
For each VL one remote fan unit is recommended.
Maximum cooktop width between 2 VL: 60 cm.
If installed next to gas appliances, the ventilation moulding LS041 001 is recommended to ensure maximum performance of the cooktop.
When having installed the ventilation moulding LS041 001 the wok pan WP 400 001 can not be used.

When installing a ventilation hood with air extraction mode and a chimney-vented fireplace, the power supply line of the ventilation appliance needs a suitable safety switch.

Please read additional planning notes on page 86.

Please read the installation details regarding air ducting on page 118 – 119.

Connection

Connecting cable 1.7 m between VL and remote fan unit.

Planning examples with the downdraft ventilation 200 series

Good to know – for correct planning and installation

- For depth measurements, take account of the depth of the furniture cavity and worktop overhangs of the kitchen furniture.
- With the Vario downdraft ventilation, the ducting can be connected to below or to the rear (in option). The respective connecting pieces are available for this purpose.
- Maximum distance between the Vario downdraft ventilation and the remote fan unit: Cable length in between 1.7 m
- For optimum air circulation, we recommend ducts with DN 150.
- 2 flat or 2 round ducts must be connected with a pipe connector.
- To connect 2 duct bends together (e.g. a 90° horizontal duct bend and a 90° vertical duct bend), a piece of flat duct is required, which can be shortened to the required length by cutting it to size.
- It is also important that ducting is well sealed in order to prevent air leaks, e.g. by using the adhesive tape AD 990 090 (UV- and heat-resistant).
- Vario cooktops with intensive vapour formation like Vario Teppan Yaki, Vario electric grill should be placed central; in case of Vario electric grill air recirculation is not recommended.

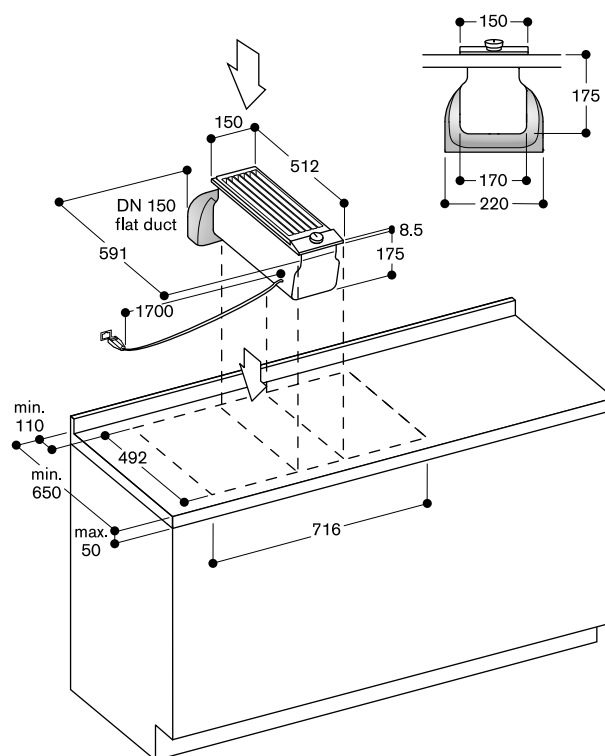

AD 410 040: Flexible connecting piece for VL 200, DN 150 flat

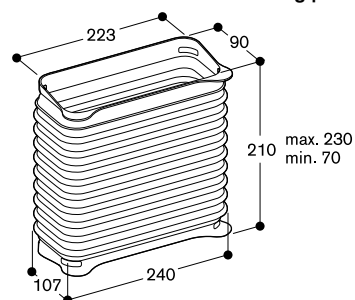

AD 851 041: Connecting piece VL 200 for extension with flat duct DN 150 for extra deep worktop

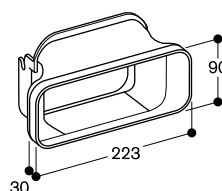

Planning examples with the downdraft ventilation 200 series

Planning example 1 (air recirculation)

VL 200 with AR 410 110 remote fan unit

Wall installation, worktop depth 65 cm, access to the filters for replacement from the front.

Good to know

- Allow accessibility to the charcoal filters in the lower cabinet for their replacement.
- Additionally, if the plinth is higher than 80 mm, the external remote fan unit has to be elevated to enable access to the filters. If the plinth is 80 mm high, the remote fan unit can be placed directly on the floor.
- For optimum performance, the recirculated air requires sufficient space to escape (outflow surface area of at least 700 cm²).

List of components

- 1 x AR 410 110 (remote fan unit air recirculation)
- 1 x AD 410 040 (Flexible connecting piece for VL 200, DN 150 flat)

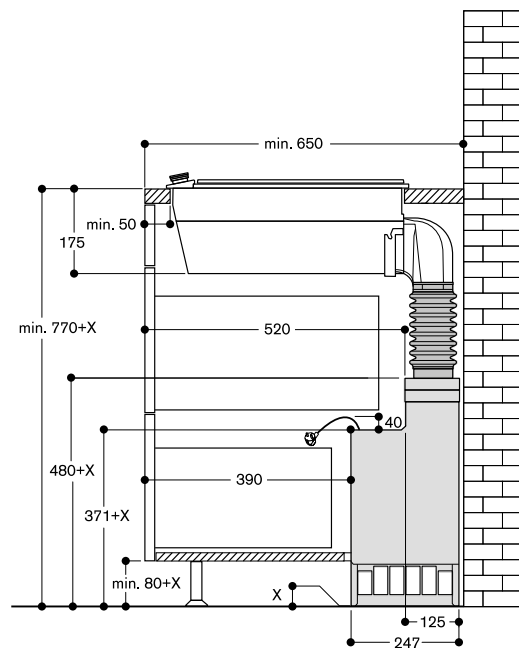
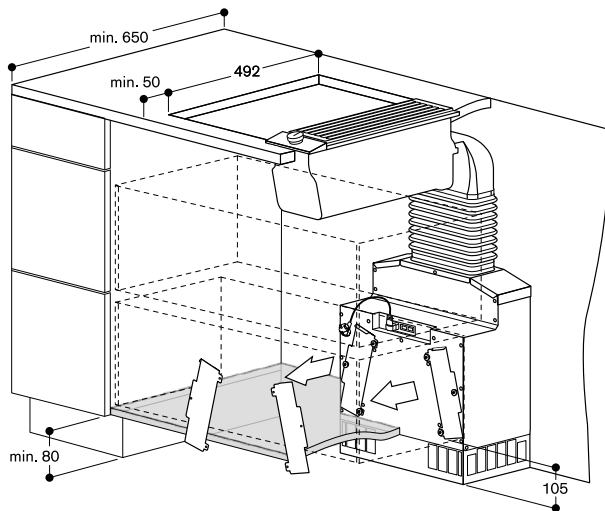

Planning example 2 (air recirculation)

VL 200 with AR 410 110 remote fan unit

Island installation, access to the filter for replacement from the front or the back.

Good to know

- Allow accessibility to the charcoal filters in the lower cabinet for their replacement.
- Additionally, if the plinth is higher than 80 mm, the external remote fan unit has to be elevated to enable access to the filters. If the plinth is 80 mm high, the remote fan unit can be placed directly on the floor.
- For optimum performance, the recirculated air requires sufficient space to escape (outflow surface area of at least 700 cm²).

List of components

- 1 x AR 410 110 (remote fan unit air recirculation)
- 1 x AD 851 041 (connecting piece for extension with flat duct for extra deep worktop)
- 1 x AD 852 030 (flat duct bend 90° vertical)
- 1 x AD 852 010 (flat duct)
- 1 x AD 410 040 (Flexible connecting piece for VL 200, DN 150 flat)
- 1 x AD 990 090 (adhesive tape for sealing the ducts)

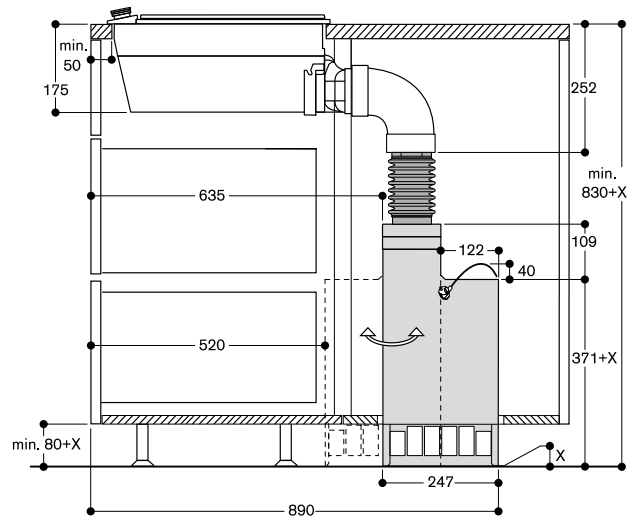
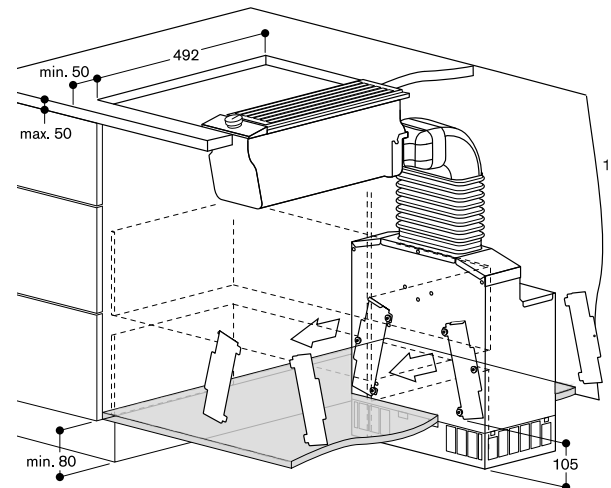

Planning example 3 (air recirculation)

VL 200 with AR 413 122 remote fan unit

Island installation, access to the filter for replacement from the front.

Good to know

- The remote fan unit can be turned in all directions, depending on the desired direction for the exhaust air or filter removal.
- Allow accessibility to the charcoal filters in the lower cabinet for their replacement.
- The recommended minimum distance between filter openings and cupboard wall if there is no ventilation grill directly in front: 15 cm.
- For optimum performance, the recirculated air requires sufficient space to escape (outflow surface area of at least 700 cm²).
- The connection piece DN 150 is included with the remote fan unit.

List of components wall installation

- 1 x AR 413 122 (remote fan unit plinth)
- 1 x AD 410 040 (Flexible connecting piece for VL 200, DN 150 flat)
- 1 x AD 852 010 (flat duct)
- 1 x AD 852 041 (flat duct adapter round)
- 1 x AD 990 090 (adhesive tape for sealing the ducts)

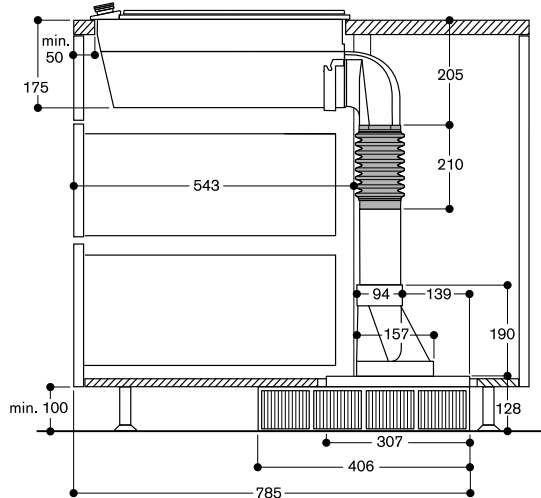
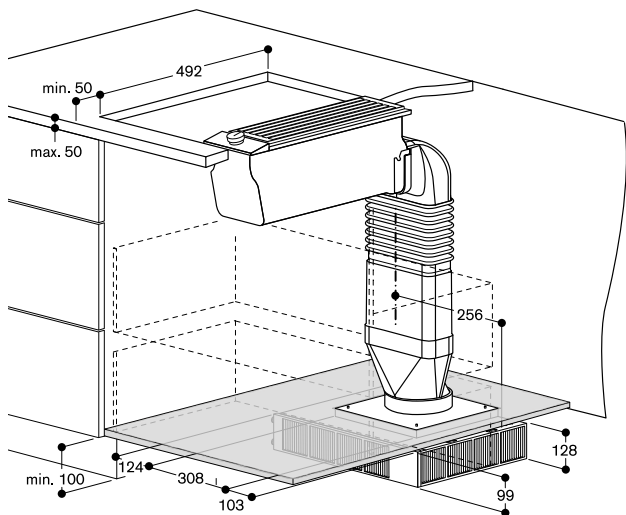

Planning example 4 (air extraction)

VL 200 with AR 403 122 remote fan unit

Island installation, connection from the right side.

List of accessories wall installation

- 1 x AR 403 122 (remote fan unit plinth)
- 1 x AD 851 041 (connecting piece for extension with flat duct for extra deep worktop)
- 1 x AD 852 030 (Flat duct bend 90° vertical)
- 1 x AD 852 010 (flat duct)
- 1 x AD 410 040 (Flexible connecting piece for VL 200, DN 150 flat)
- 1 x AD 852 041 (flat duct adapter round)
- 1 x AD 990 090 (adhesive tape for sealing the ducts)

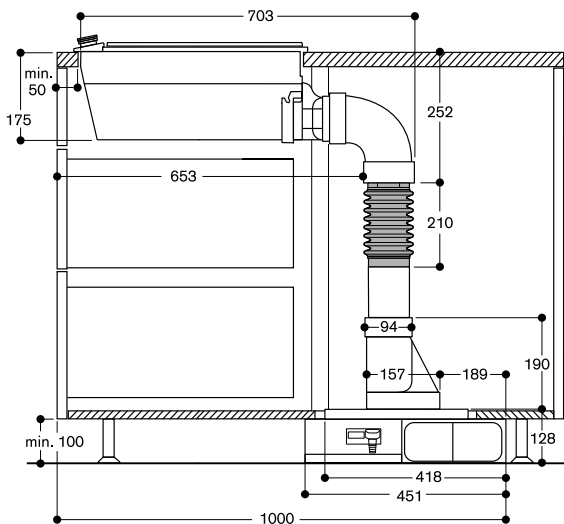
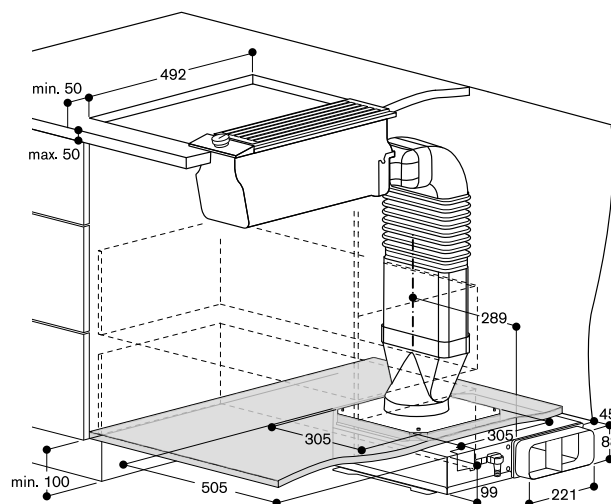



AR 401 142

Stainless steel
 Max. air output 910 m³/h
 Air extraction
 Outside wall mounting

Installation accessories

AD 702 052
 Telescopic wall-duct
 Connection piece DN 200 round

Installation accessories for the air recirculation ducts you will find on pages 132 – 139.

**Remote fan unit 400 and 200 series
 AR 401**

- Powerful remote fan unit to combine with Vario downdraft ventilation 400 and 200 series
- Efficient BLDC technology

Output

Performance output level 3/Intensive:
 Air output according to EN61591.
 Sound power and sound pressure depending on built-in situation.
 Air extraction:
 720 / 910 m³/h.
 Power levels depend on the motorless appliances, see table on page 104.

Features

3 electronically controlled power levels and one intensive mode.
 Fan technology with highly efficient, brushless DC motor (BLDC).
 Including sound insulation to minimise the noise level.
 Stainless steel housing.
 Pipe connection pieces on intake side: 1x DN 200 round.
 Retaining bracket for installation on an outside wall enclosed.

Planning notes

Powerful remote fan unit to combine with Vario downdraft ventilation 400 and 200 series.
 Connection to the respective appliances via network cable.
 Installation in an exterior area allows for a reduced noise level in the kitchen
 Installation on an outside wall.
 Control box must be installed indoors.
 Acceptable temperature range for installation of the control box:
 -25 to 60 °C.
 Distance for free air space from ground (or other object) to center of the pipe: min 60 cm
 When installing a ventilation hood with air extraction mode and a chimney-vented fireplace, the power supply line of the ventilation appliance needs a suitable safety switch.

Connection

Total connected load 180 W.
 Connecting cable 1.8 m, with plug.
 Network cable 5 m.

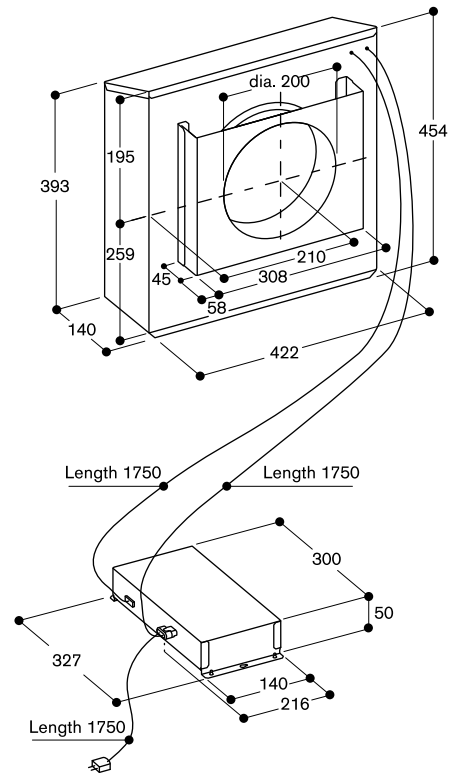

**AR 410 110**

Metal housing
 Max. air output 660 m³/h
 Air recirculation
 Installation in the cupboard

Installation accessories for the air recirculation ducts you will find on pages 132 – 139.

Remote fan unit 400 and 200 series
AR 410

- Powerful remote fan unit to combine with Vario downdraft ventilation 400 and 200 series
- Efficient BLDC technology
- Particularly quiet due to patented noise insulation
- Compact, space-saving installation

Output

Performance output level 3/Intensive:
 Air output according to EN 61591.
 Sound power and sound pressure depending on built-in situation.
 Air recirculation:
 570 / 660 m³/h.
 Power levels depend on the motorless appliances, see table on page 104.

Features

3 electronically controlled power levels and 1 intensive mode.
 Fan technology with highly efficient, brushless DC motor (BLDC).
 Including sound insulation to minimise the noise level.
 Steel housing, zinc-plated.
 Pipe connection piece on intake side:
 1 x DN 150 flat duct.
 Retaining bracket for installation at the furniture base enclosed.
 2 activated charcoal filters enclosed ex factory.
 Filter is suitable for the preparation of fish and seafood due to special treatment.
 Filter replacement interval: 1 year depending on cooking frequency.

Planning notes

Powerful remote fan unit to combine with Vario downdraft ventilation 400 and 200 series.
 Connection to the respective appliances via network cable.
 Installation in a cupboard possible with a cut-out in the furniture base or behind the cupboard positioned on the floor.
 To replace the filter the remote fan unit must be accessible.
 The charcoal filter exchange is possible from both sides.

Connection

Total connected load 170 W.
 Connecting cable 1.8 m, with plug.
 Network cable 5 m.

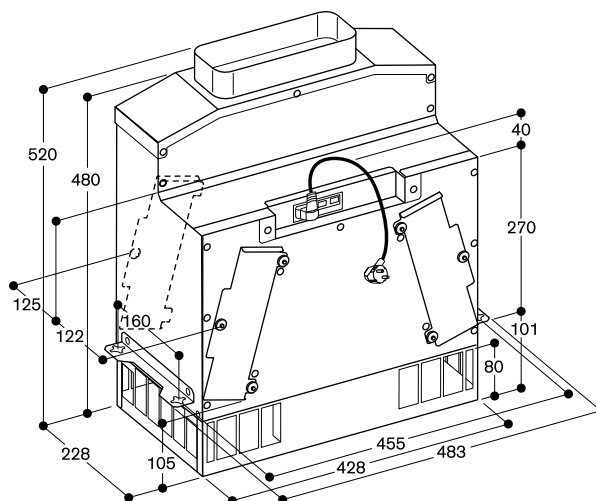
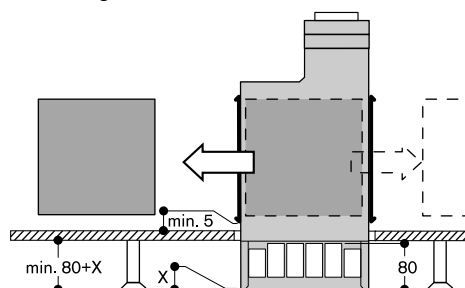
**Filter exchange**



AR 403 122

Metal housing

Max. air output 890 m³/h

Air extraction

Plinth installation

Installation accessories for the air recirculation ducts you will find on pages 132 – 139.

Remote fan unit 400 and 200 series

AR 403

- Powerful remote fan unit to combine with motorless appliances 400 series and Vario downdraft ventilation 200 series
- Efficient BLDC technology
- Compact and space-saving installation in a 10 cm high plinth

Output

Performance output level 3/Intensive:

Air output according to EN 61591.

Sound power and sound pressure depending on built-in situation.

Air extraction:

730 / 890 m³/h.

Power levels depend on the motorless appliances, see table on page 104.

Features

3 electronically controlled power levels and one intensive mode.

Fan technology with highly efficient, brushless DC motor (BLDC).

Steel housing, zinc-plated.

Pipe connection pieces on intake side:

1 x DN 150 round.

Pipe connection pieces on output side:

1 x DN 150 flat duct.

Retaining bracket for installation on the ceiling or side of a cupboard enclosed.

Planning notes

Remote fan unit in combination with motorless appliances 400 series and Vario downdraft ventilation 200 series.

Connection to the respective appliances via network cable.

Installation in the plinth with cut-out for the air ducting in the furniture base.

Connection of AL 400 with an air collector box (AD 704 048, AD 704 049).

When installing a ventilation hood with air extraction mode and a chimney-vented fireplace, the power supply line of the ventilation appliance needs a suitable safety switch.

Connection

Total connected load 180 W.

Connecting cable 1.8 m, with plug.

Network cable 2 m.

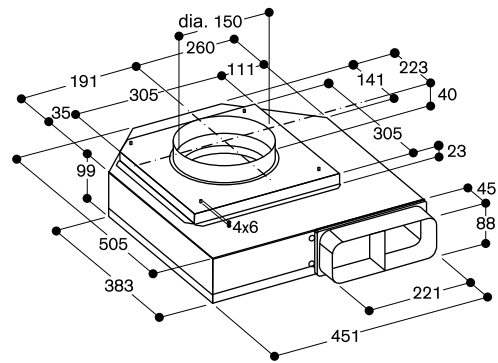

**AR 413 122**

Metal housing
Max. air output 850 m³/h
Air recirculation
Plinth installation

Installation accessories**AA 010 410**

Air exhaust grill air recirculation
Stainless steel-coloured, 90 cm,
including installation fittings, height
adjustable.

**Installation accessories for the air
recirculation ducts you will find on
pages 132 – 139.**

**Remote fan unit 400 and 200 series
AR 413**

- Powerful remote fan unit to combine with motorless appliances 400 series and Vario downdraft ventilation 200 series
- Efficient BLDC technology
- Compact and space-saving installation in a 10 cm high plinth

Output

Performance output level 3/Intensive:
Air output according to EN 61591.
Sound power and sound pressure
depending on built-in situation.
Air recirculation:
680 / 850 m³/h.
Power levels depend on the motorless
appliances, see table on page 104.

Features

3 electronically controlled power levels
and one intensive mode.
Fan technology with highly efficient,
brushless DC motor (BLDC).
Steel housing, zinc-plated.
Pipe connection pieces on intake side:
1 x DN 150 round.
Retaining bracket for installation on the
ceiling or side of a cupboard enclosed.
2 activated charcoal filters enclosed
ex factory.
Filter is suitable for the preparation
of fish and seafood due to special
treatment.
Filter replacement interval:
1 year depending on cooking
frequency.

Planning notes

Remote fan unit in combination with
motorless appliances 400 series and
Vario downdraft ventilation
200 series.
Connection to the respective
appliances via network cable.
Installation in the plinth with cut-out for
the air ducting in the furniture base.
Filter replacement interval: 1-1.5 years
depending on cooking frequency.
It must be possible to remove the plinth
to replace the filter.
Recommended minimum gap between
filter openings and cupboard wall if
there is no ventilation grill directly in
front: 15 cm.

Connection

Total connected load 180 W.
Connecting cable 1.8 m, with plug.
Network cable 2 m.

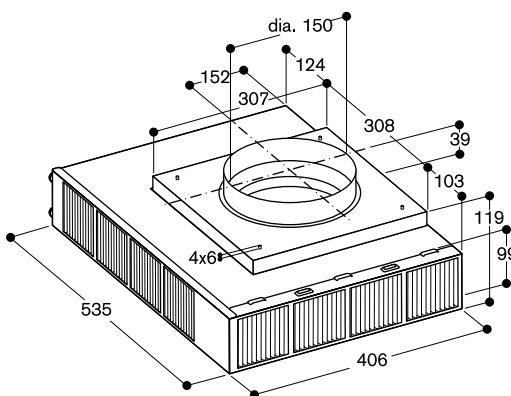
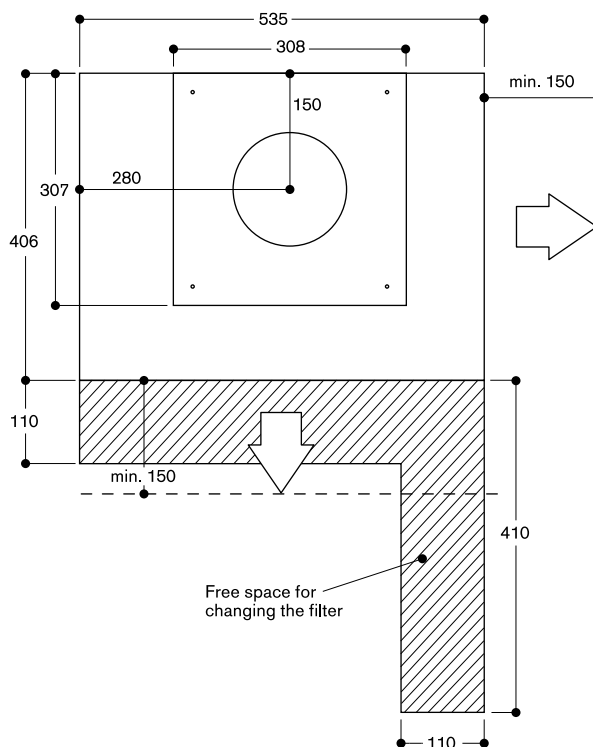
**View from above**



AI 240 120 ▲

Stainless steel with stainless steel control panel
Width 120 cm
Air extraction/Air recirculation
Delivery with mounting kit and chimney

AI 240 190 ▲

Stainless steel with stainless steel control panel
Width 90 cm
Air extraction/Air recirculation
Delivery with mounting kit and chimney

Installation accessories

AD 200 326

Stainless steel chimney extension
Length: 1100 mm

AD 220 396

Ceiling collar for chimneys
Stainless steel

AD 223 346

Extension for mounting kit 500 mm

Special accessories

AA 200 110

1 activated charcoal filter with high efficient odour reduction due to increased surface. For air recirculation module AA 200 812/816 and AA 010 810.

AA 200 816

Air recirculation module inclusive 1 activated charcoal filter with high efficient odour reduction due to increased surface
For air recirculation.
Can be combined with island hoods.

Installation accessories for the air recirculation ducts you will find on pages 132 – 139.

Island hood 200 series

AI 240

- Timeless, elegant design
- Highly efficient extraction of cooking vapours
- Energy-saving, low-noise fan
- Patented filter technology with high grease absorption
- Rim extraction filter with flat and easy-to-clean stainless steel underside
- Function for automatic, sensor-controlled power adjustment depending on the build-up of cooking vapours
- Dimmable, neutral white LED light for ideal illumination of the whole cooktop
- Air extraction or air recirculation system
- Air recirculation module with activated charcoal filters: quiet and highly efficient air recirculation solution with odour reduction as in air extraction mode and long replacement intervals

Output

Performance and noise level, output level 3/Intensive:

Air output according to EN 61591.

Sound power level according to EN 60704-3.

Sound pressure level according to EN 60704-2-13.

Odour reduction for air recirculation in accordance with EN 61591.

Appliance width 120 cm

Air extraction:

640 / 890 m³/h.

62 / 69 dB (A) re 1 pW.

48 / 55 dB (A) re 20 µPa.

Air recirculation:

470 / 570 m³/h.

68 / 72 dB (A) re 1 pW.

54 / 58 dB (A) re 20 µPa.

Odour reduction air recirculation 95%.

Appliance width 90 cm

Air extraction:

620 / 850 m³/h.

62 / 69 dB (A) re 1 pW.

48 / 55 dB (A) re 20 µPa.

Air recirculation:

480 / 570 m³/h.

68 / 72 dB (A) re 1 pW.

54 / 58 dB (A) re 20 µPa.

Odour reduction air recirculation 95%.

Features

3 electronically controlled power levels and 1 intensive mode.

Automatic function with sensor-controlled run-on function.

Grease filter saturation indicator.

Patented rim extraction filter, dishwasher-safe.

Neutral white LED light (3600 K), continuously dimmable.

Lamp output 4x5 W.

Illuminance 730 lx.

Fan technology with highly efficient, brushless DC motor (BLDC).

Airflow-optimised interior for efficient air circulation.

The package includes an one-way flap.

Consumption data

Energy consumption

51.6/52.5 kWh/year.

Sound level min./max. normal mode
40/62 dB.

Planning notes

The package includes the mounting kit and the two-part chimney with the dimensions from 674 mm to 854 mm. Individual planning solutions can be implemented using the special accessory chimney extension AD 200 326 in combination with extension for mounting kit AD 223 346. Special chimney types are available upon request.

Minimum clearance between gas cooktop(s) with more than 39.6 MJ/h and ventilation hood 70 cm. For more details, please refer to gas cooktop(s) installation manual(s).

Clearance above electric appliances min. 55 cm.

The air recirculation module with activated charcoal filter can be installed on the inner chimney. When installing a ventilation hood with air extraction mode and a chimney-vented fireplace, the power supply line of the ventilation appliance needs a suitable safety switch.

Connection

Total connected load 280 W.

Power requirements

220 – 240 V / 50 Hz.

Connecting cable 1.3 m with plug.

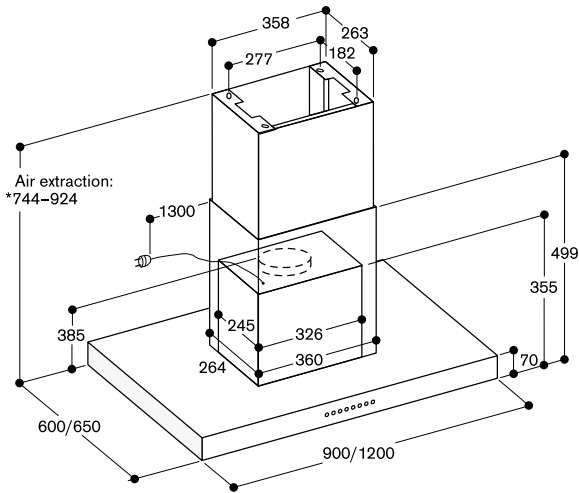

* Suitable for ceiling heights from 2.34 m to 2.52 m;
Specifications refer to the distance of 1.60 m from
the floor to the lower edge of the hood.

AI 240 with AA 200 816

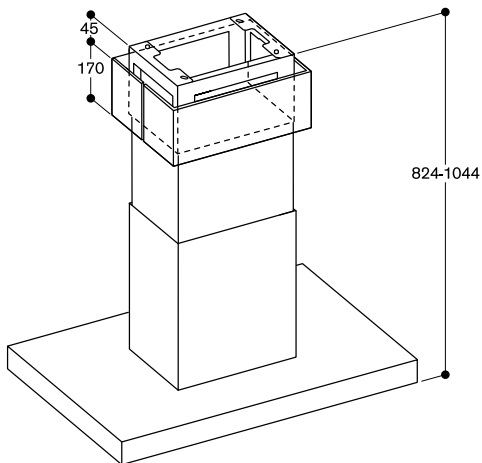

* Suitable for ceiling heights from 2.42 m to 2.64 m;
Specifications refer to the distance of 1.60 m from
the floor to the lower edge of the hood.

AI 240 with AD 200 326 and AD 223 346

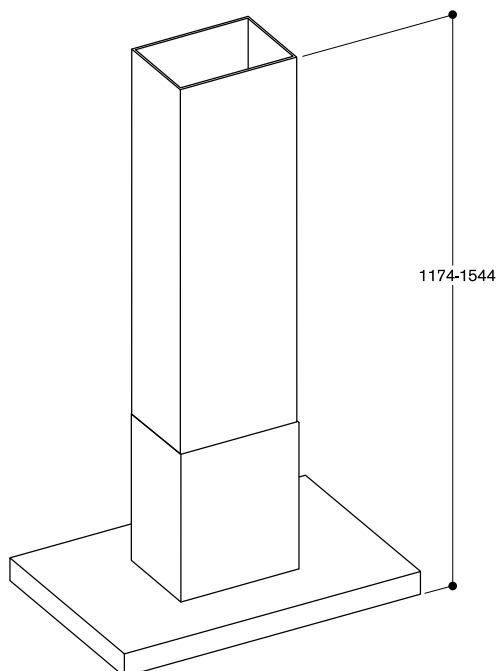

* Suitable for ceiling heights from 2.78 m to 3.15 m;
Specifications refer to the distance of 1.60 m from the floor
to the lower edge of the hood.



AW 240 190

Stainless steel with stainless steel control panel
Width 90 cm
Air extraction/Air recirculation
Delivery with chimney

Installation accessories

AD 200 322

Stainless steel chimney extension
Length: 1000 mm

AD 200 392

Ceiling collar for chimneys
Stainless steel

Special accessories

AA 200 110

1 activated charcoal filter with high efficient odour reduction due to increased surface. For air recirculation module AA200812/816 and AA010810.

AA 200 812

Air recirculation module inclusive 1 activated charcoal filter with high efficient odour reduction due to increased surface
For air recirculation.
Can be combined with wall mounted hoods.

Installation accessories for the air recirculation ducts you will find on pages 132 – 139.

Wall mounted hood 200 series

AW 240

- Timeless, elegant design
- Highly efficient extraction of cooking vapours
- Energy-saving, low-noise fan
- Patented filter technology with high grease absorption
- Rim extraction filter with flat and easy-to-clean stainless steel underside
- Function for automatic, sensor-controlled power adjustment depending on the build-up of cooking vapours
- Dimmable, neutral white LED light for ideal illumination of the whole cooktop
- Air extraction or air recirculation system
- Air recirculation module with activated charcoal filters: quiet and highly efficient air recirculation solution with odour reduction as in air extraction mode and long replacement intervals

Output

Performance and noise level, output level 3/Intensive:

Air output according to EN 61591.

Sound power level according to EN 60704-3.

Sound pressure level according to EN 60704-2-13.

Odour reduction for air recirculation in accordance with EN 61591.

Appliance width 90 cm

Air extraction:

610 / 810 m³/h.

66 / 72 dB (A) re 1 pW.

52 / 58 dB (A) re 20 µPa.

Air recirculation:

450 / 530 m³/h.

70 / 74 dB (A) re 1 pW.

56 / 60 dB (A) re 20 µPa.

Odour reduction air recirculation 95%.

Features

3 electronically controlled power levels and 1 intensive mode.

Automatic function with sensor-controlled run-on function.

Grease filter saturation indicator.

Patented rim extraction filter, dishwasher-safe.

Neutral white LED light (3600 K), continuously dimmable.

Lamp output 4x 5 W.

Illuminance 929 lx.

Fan technology with highly efficient, brushless DC motor (BLDC).

Airflow-optimised interior for efficient air circulation.

Easy mounting system for simple installation and alignment.

The package includes an one-way flap.

Consumption data

Energy consumption

38.8 kWh/year.

Sound level min./max. normal mode

44/66 dB.

Planning notes

The package includes the two-part chimney with the dimensions from 582 mm to 884 mm. Individual planning solutions can be implemented using the special accessory chimney

extension AD 200 322 or by shortening the lower edge of the inner chimney.

Minimum clearance between gas cooktop(s) with more than 39.6 MJ/h and ventilation hood 70 cm. For more details, please refer to gas cooktop(s) installation manual(s).

Clearance above electric appliances min. 55 cm.

The air recirculation module with activated charcoal filter can be installed on the external chimney or inner chimney.

When installing a ventilation hood with air extraction mode and a chimney-vented fireplace, the power supply line of the ventilation appliance needs a suitable safety switch.

Connection

Total connected load 275 W.

Power requirements

220 – 240 V / 50 Hz.

Connecting cable 1.3 m with plug.

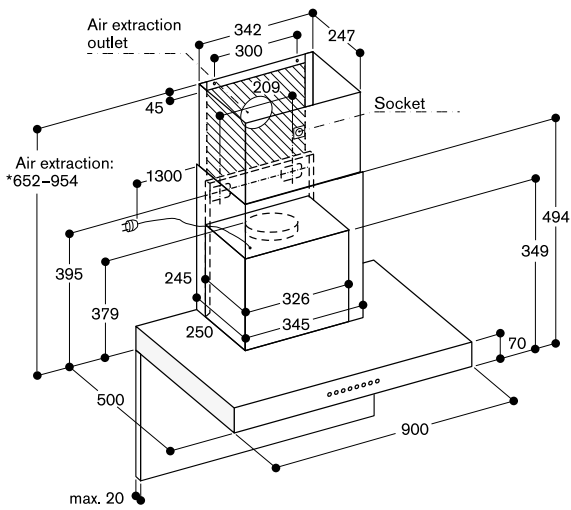

* Suitable for ceiling heights from 2.25 m to 2.55 m;
 Specifications refer to the distance of 1.60 m from the floor
 to the lower edge of the hood.

AW 240 with AA 200 812

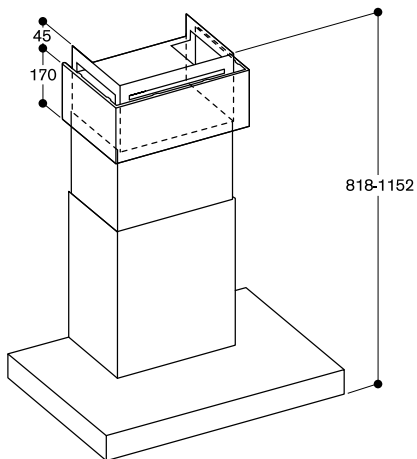

* Suitable for ceiling heights from 2.45 m to 2.75 m;
 Specifications refer to the distance of 1.60 m from the floor
 to the lower edge of the hood.

AW 240 with AD 200 322

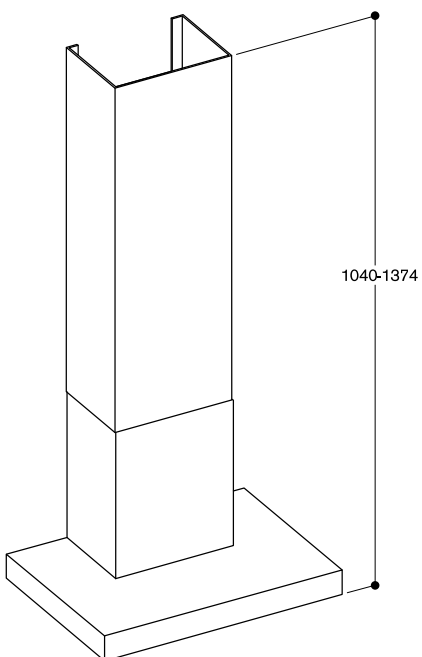

* Suitable for ceiling heights from 2.64 m to 2.97 m;
 Specifications refer to the distance of 1.60 m from the floor
 to the lower edge of the hood.



AF 210 191

Stainless steel handle bar
Width 90 cm

Air extraction/Air recirculation

AF 210 161

Stainless steel handle bar
Width 60 cm

Air extraction/Air recirculation

Installation accessories

AA 210 460

Lowering frame for 60 cm slide out rangehood

AA 210 490

Lowering frame for 90 cm slide out rangehood

AA 210 491

Assembly kit for 90 cm upper cabinet

Special accessories

AA 210 110

1 activated charcoal filter with high efficient odour reduction due to increased surface. For air recirculation module AA 211 812.

AA 211 812

Patented air recirculation module including 1 activated charcoal filter with high efficient odour reduction due to increased surface
For air recirculation.

Installation accessories with further details on pages 132 – 139.

Slide out rangehood 200 series

AF 210

- Unobtrusive slide out rangehood design thanks to integrated glass panel in the steam screen
- Especially quiet operation thanks to integrated sound insulation
- Steam screen extends by touching the handle bar
- Steam screen and visible corpus made of brushed stainless steel
- Especially high air output
- Energy-saving, low-noise fan
- Function for automatic, sensor-controlled power adjustment depending on the build-up of cooking vapours
- Dimmable, neutral white LED light for ideal illumination of the whole cooktop
- The patented lowering frame allows the slide out rangehood to disappear completely into the upper cabinet
- Air extraction or air recirculation system
- Air recirculation module with activated charcoal filters: quiet and highly efficient air recirculation solution with odour reduction as in air extraction mode and long replacement intervals

Output

Performance and noise level, output level 3/Intensive:

Air output according to EN 61591.

Sound power level according to EN 60704-3.

Sound pressure level according to EN 60704-2-13.

Odour reduction for air recirculation in accordance with EN 61591.

Appliance width 90 cm

Air extraction:

520 / 930 m³/h.

56 / 70 dB (A) re 1 pW.

52 / 56 dB (A) re 20 µPa.

Air recirculation:

510 / 890 m³/h.

62 / 69 dB (A) re 1 pW.

48 / 55 dB (A) re 20 µPa.

Odour reduction air recirculation 91%.

Appliance width 60 cm

Air extraction:

520 / 920 m³/h.

56 / 70 dB (A) re 1 pW.

42 / 56 dB (A) re 20 µPa.

Air recirculation:

520 / 900 m³/h.

62 / 69 dB (A) re 1 pW.

48 / 55 dB (A) re 20 µPa.

Odour reduction air recirculation 91%.

Features

Controls at front.

3 electronically controlled power levels and 1 intensive mode.

Automatic function with sensor-controlled run-on function.

Grease filter saturation indicator.

Stainless steel grease filter, dishwasher-safe.

Neutral white LED light (3500 K), continuously dimmable.

Lamp output 3x9 W.

Illuminance 708 lx.

Light can be switched on separately.

Fan technology with highly efficient, brushless DC motor (BLDC).

Integrated sound insulation for quiet operation.

The fan is activated when the steam screen is extended.

Patented technology for extension of the steam screen.

Extendable steam screen 198 mm.

Airflow-optimised interior for efficient air circulation and ease of cleaning.

Patented easy mounting system for simple installation.

The package includes an one-way flap.

Consumption data

Energy consumption

38.3/36.5 kWh/year.

Sound level min./max. normal mode

40/56 dB.

Planning notes

Patented air recirculation module with activated charcoal filter can be installed in the upper cabinet. The activated carbon filter can be changed from the front by simply pulling out the activated charcoal filter.

The door of the upper cabinet must be fully open in order to change the activated charcoal filter.

To be installed in an upper cabinet without base.

The required cavity depth of the upper cabinet together with the lowering frame measures 335 mm.

The required cavity height of the upper cabinet together with the lowering frame measures 600 mm.

Minimum clearance between gas cooktop(s) with more than 39.6 MJ/h and ventilation hood 70 cm. For more details, please refer to gas cooktop(s) installation manual(s).

Clearance above electric appliances min. 43 cm.

When installing a ventilation hood with air extraction mode and a chimney-vented fireplace, the power supply line of the ventilation appliance needs a suitable safety switch.

Connection

Total connected load 269/266 W.

Power requirements

220 – 240 V / 50 – 60 Hz.

Connecting cable 1.8 m, with plug.

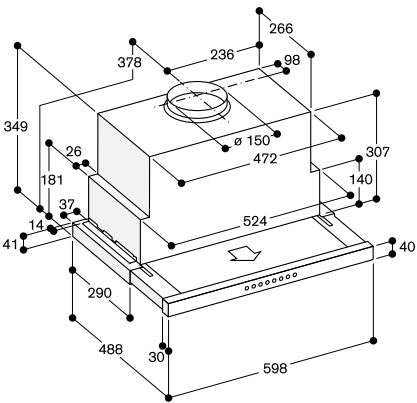
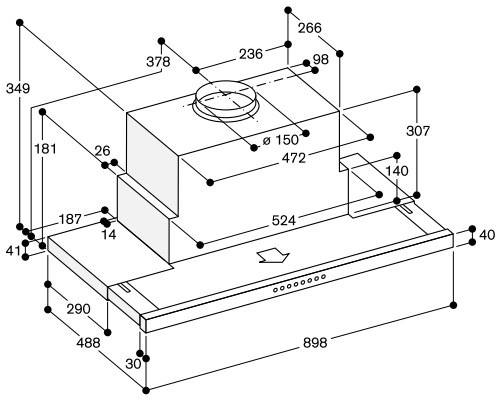

Cross-section of upper cabinet with AA 211 812 and AA 210 490/460 lowering frame

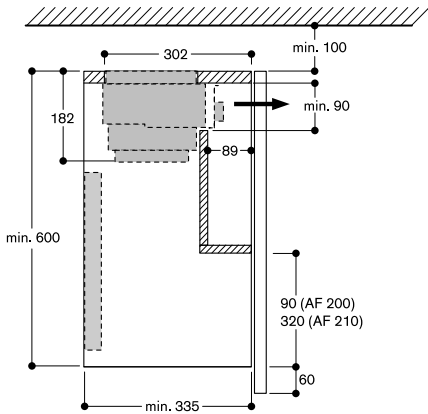

Cross-section of upper cabinet with AA 211 812

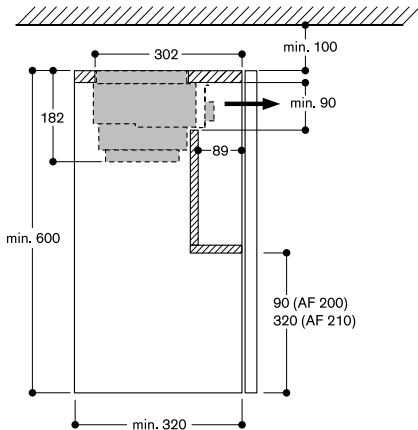

View of upper cabinet from above with AA 210 812

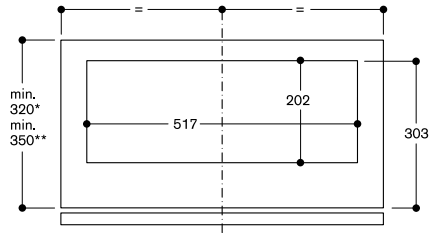

* Appliance only
** Appliance with AA 210 490/460 lowering frame

Upper cabinet for AF 210/211

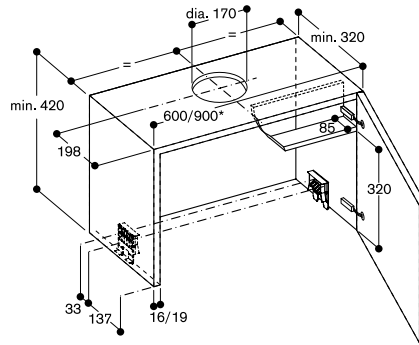

* for upper cabinets measuring 90 cm, the AA 210 491 installation set is required in addition

Upper cabinet for AF 210/211 with AA 210 460/AA 210 490 lowering frame

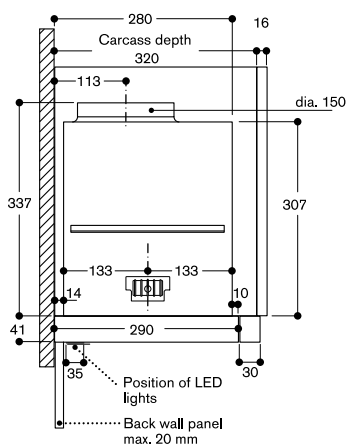
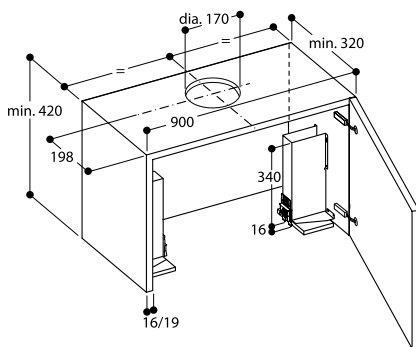
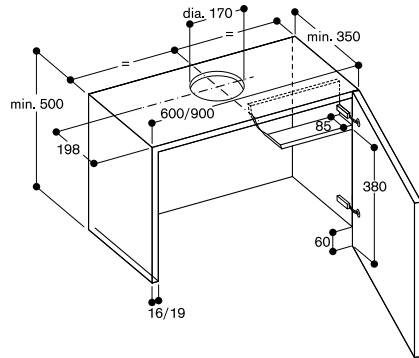



AC 200 191

Stainless steel and glass

Width 86 cm

Air extraction / Air recirculation

AC 200 161

Stainless steel and glass

Width 52 cm

Air extraction / Air recirculation

Special accessories**AA 200 510**

Remote control for integrated rangehood AC 200

AA 210 110

1 activated charcoal filter with high efficient odour reduction due to increased surface. For air recirculation module AA 211 812.

AA 211 812

Patented air recirculation module including 1 activated charcoal filter with high efficient odour reduction due to increased surface. For air recirculation.

Installation accessories for the air recirculation ducts you will find on pages 132 – 139.

Integrated rangehood 200 series**AC 200**

- Can be integrated invisibly in upper cabinet
- Energy-saving, low-noise fan
- Rim extraction with flat and easy-to-clean glass cover
- Dimmable, neutral white LED light for ideal illumination of the whole cooktop
- Air extraction or air recirculation system
- Energy efficiency class A++

Output

Performance and noise level, output level 3/Intensive:

Air output according to EN61591.

Sound power level according to EN 60704-3.

Sound pressure level according to EN 60704-2-13.

Odour reduction for air recirculation in accordance with EN61591.

Appliance width 86 cm

Air extraction:

570 / 800 m³/h.

64 / 70 dB (A) re 1 pW.

51 / 57 dB (A) re 20 µPa.

Air recirculation:

540 / 790 m³/h.

72 / 77 dB (A) re 1 pW.

59 / 65 dB (A) re 20 µPa.

Odour reduction air recirculation 94%.

Appliance width 52 cm

Air extraction:

540 / 730 m³/h.

64 / 70 dB (A) re 1 pW.

51 / 57 dB (A) re 20 µPa.

Air recirculation:

530 / 690 m³/h.

70 / 77 dB (A) re 1 pW.

59 / 64 dB (A) re 20 µPa.

Odour reduction air recirculation 92%.

Features

3 electronically controlled power levels and 1 intensive mode.

Remote control is available as a special accessory.

Interval ventilation, 6 min.

Run-on function, 6 min.

Grease filter saturation indicator.

Metal grease filter, dishwasher-safe.

Glas filter cover.

Neutral white LED light (4000 K), dimmable.

Lamp output 2x 1 W.

Illuminance 266 lx.

Fan technology with highly efficient, brushless DC motor (BLDC).

Consumption data

Energy consumption

25.5/29.6 kWh/year.

Sound level min. 41/44 dB /

max. 64/67 dB normal mode.

Planning notes

Patented air recirculation module with activated charcoal filter can be installed in the upper cabinet. The activated carbon filter can be changed

from the front by simply pulling out the filter drawer.

The door of the upper cabinet must be fully open in order to change the activated charcoal filter.

Can be integrated invisibly in upper cabinet.

Vario cooktops with intensive production of vapours like VR/VP should be placed in the middle beneath the hood (in this case air recirculation is not recommended). Minimum clearance between gas cooktop(s) with more than 39.6 MJ/h and ventilation hood 70 cm. For more details, please refer to gas cooktop(s) installation manual(s).

Clearance above electric appliances min. 50 cm.

When installing a ventilation hood with air extraction mode and a chimney-vented fireplace, the power supply line of the ventilation appliance needs a suitable safety switch.

Connection

Total connected load 172 W.

Connecting cable 1.0 m with plug.

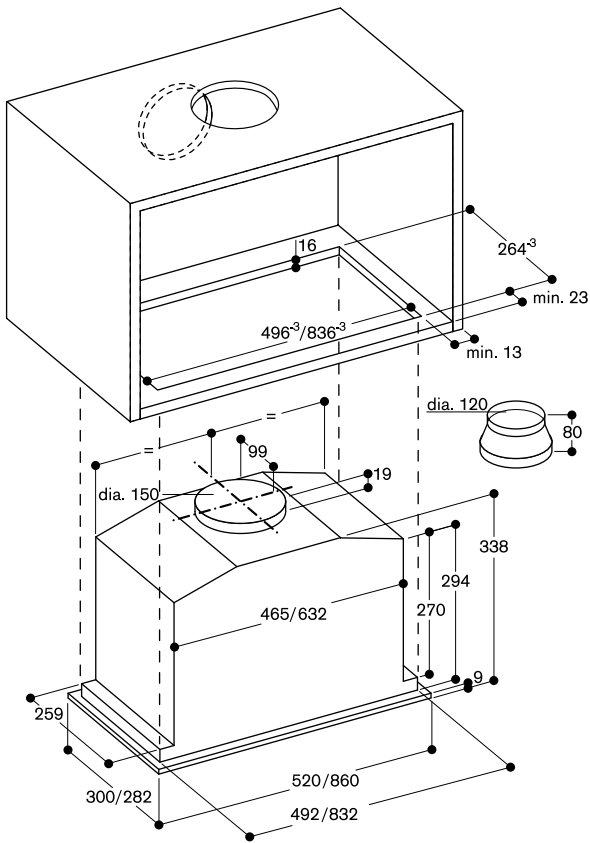

View of upper cabinet from above with AC 200 and AA 211 812

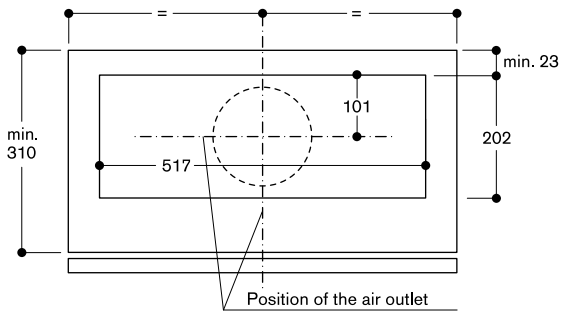

Cross-section of upper cabinet with AC 200 and AA 211 812

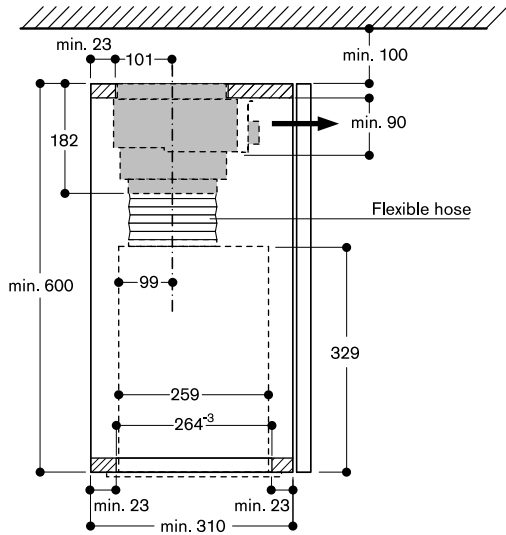

Accessories | special accessories for ventilation appliances

AA 200 812

For air recirculation.
Can be combined with wall mounted hoods AW 240
Odour reduction comparable to air extraction mode (95%).
Noise reduction of up to 3 dB when compared to conventional recirculation filter systems.
Extended change interval for the activated charcoal filter.
For installation on the external chimney or internal chimney.
Includes design panel, wall fastening, activated charcoal filter, flexible hose and 2 hose clamps.

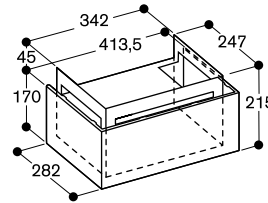

AA 200 816

For air recirculation.
Can be combined with island hoods AI 240.
Odour reduction comparable to air extraction mode (95%).
Noise reduction of up to 3 dB when compared to conventional air recirculation filter systems.
Extended change interval for the activated charcoal filter.
For installation on the internal chimney.
Includes design panel, activated charcoal filter, flexible hose and 2 hose clamps.

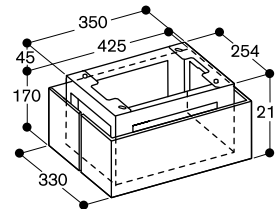

AA 211 812

Patented air recirculation module including 1 activated charcoal filter with high efficient odour reduction due to increased surface
For air recirculation.
Can be combined with slide out rangehood series 200/integrated rangehood 200 series.
Odour reduction comparable to air extraction mode (95%).
Noise reduction of up to 3 dB when compared to conventional air recirculation filter systems.
Extended change interval for the activated charcoal filter.
For assembly in the upper cabinet.
Consisting of filter housing with design panel, activated charcoal panel, activated charcoal filter, flexible hose and 2 hose clamps.

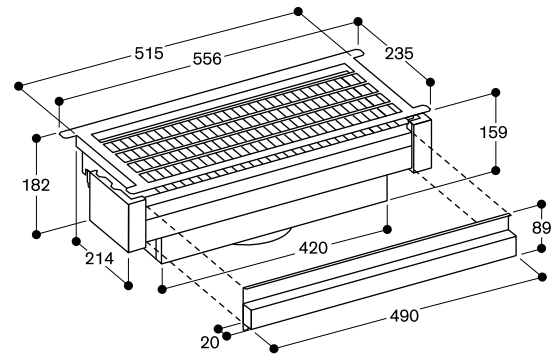

Removable filter panel

AD 200 392 for AW 240

AD 220 396 for AI 240

Ceiling collar for air chimneys

Stainless steel/aluminium-lacquered

Covers the fixing screws of wall and island air chimneys as well as uneven gaps at not exactly horizontal ceilings.
Allows the installation of customised one-piece wall chimneys and island chimneys without telescope.



Features

Ceiling fixture for duct and clip-on cover in the color of chimney.

Planning notes

Available for most of the Gaggenau chimney dimensions to fit with standard chimneys.

AD 200 326

Stainless steel chimney extension
110cm, suits AI 240.
Order AD 200 326 and AD 223 346
in conjunction.



AD 200 322

Stainless steel chimney extension
100cm, suits AW 240



AA 200 110 ▲

Active charcoal filter for retrofitting
circulation module
AA 200 812/816



AA 210 110 ▲

Charcoal filter to suit AF 210. Required
for air circulation module AA 211 812

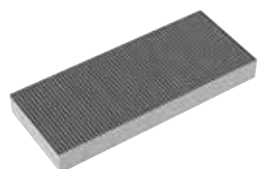

Accessories | special accessories for ventilation appliances

Extension for mounting kit for island hood AI 240 AD 223 346

For a chimney height of 1100–1500 mm.
Appliance height is dependent on the structure (cabinet height).

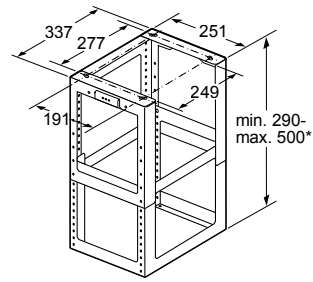

* height-adjustable
in 10 mm increments

measurements in mm

AA 210 490

Lowering frame for 90 cm slide out rangehood

AA 210 460

Lowering frame for 60 cm slide out rangehood

Can be combined with slide out rangehood series 200.

The patented lowering frame allows the slide out rangehood to disappear completely into the upper cabinet.

For assembly directly on the kitchen wall or reinforced upper cabinet.

For assembly in the upper cabinet. The required cavity depth of the upper cabinet together with the lowering frame measures 335 mm.

In combination with a back wall panel > 5 mm the lowering frame needs to be lined and the cavity depths must be adapted accordingly.

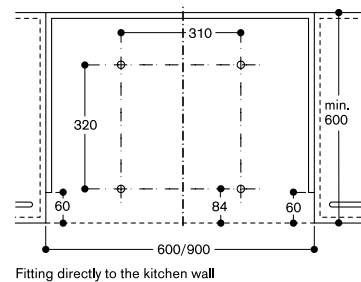
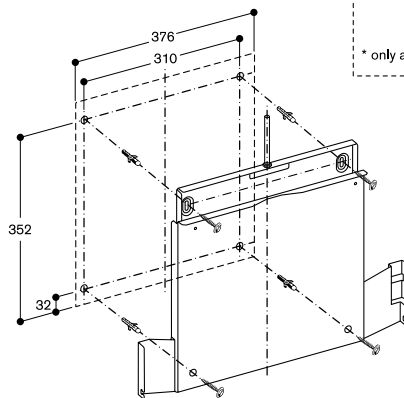
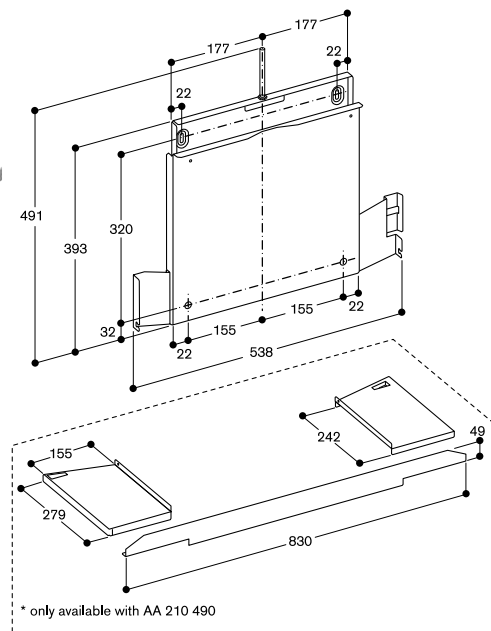

AA 210 491

Assembly kit for 90 cm upper cabinet

Can be combined with the 90 cm wide slide out rangehoods 200 series.

Slide out rangehood of 200 series
For left/right assembly in upper cabinets.

For assembly in the upper cabinet.

If the lowering frame AA 210 490 is used, the assembly kit is not needed

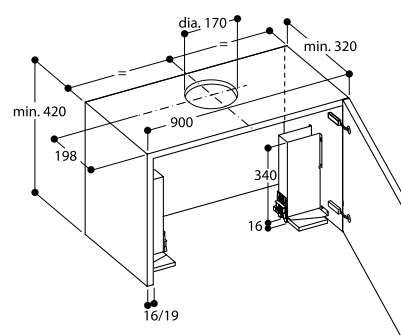

AA 200 510
Remote control for integrated
rangehood AC 200



Wall outlet

Wall outlets are available that are suitable for providing a clean, efficient and unobtrusive method of routing ducting through outside walls. The aperture should always correspond to, or be bigger than, the nominal width of the type of pipe used.

AD 700 051
Wall outlet
Stainless steel
DN 200 round

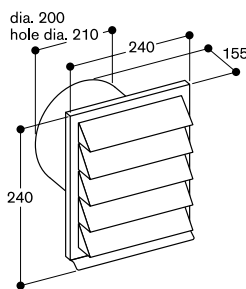

Little loss of airflow due to large stainless steel outlet louvers.

Features

Weatherproof stainless steel louvers.
Integrated one-way flap.
Connecting piece DN 200 round

Planning notes

For use with telescopic wall-duct
AD 702
Wall breakthrough \varnothing 210 mm

AD 702 052
Telescopic wall-duct
DN 200 round

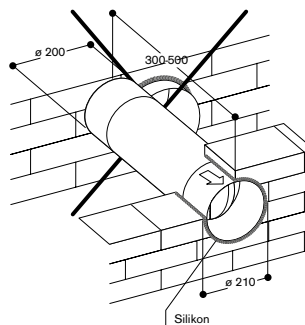

Features

Connecting piece DN 200 round.
Integrated one-way flap.

Planning notes

For use with wall outlet AD 700 051 or
remote fan unit AR 401.

AD 750 053
Wall outlet with telescopic duct
Stainless steel/plastic
DN 150 round

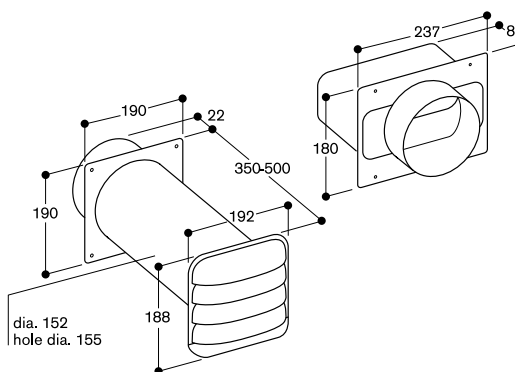

Optimal temperature insulation.
Hermetically sealed by an optimized built-in heat retention system. Flat stainless steel cover with minimal effect to the aesthetics of the building exterior facade.

Features

Weatherproof stainless steel louvers.
3-times insulating backflow system.
Magnetic opening and closing.
Defined opening pressure (65 Pa) prevents rattling.
Full opening even at low flow rates.
Telescopic wall duct 350 - 500 mm for round pipe connection piece DN 150.

Planning notes

Conform to blower-door test.
For connection of round pipe DN 150 or flat pipe DN 150. Wall breakthrough \varnothing 155 mm.

Accessories | special accessories for ventilation appliances

Excellent performance thanks to optimal ducting and installation.

Intelligently selecting and installing the duct system not only has a very positive effect on the output of the ventilation system; it also minimises the noise generated. It is therefore decisive for the efficiency of the entire ventilation system.

The duct type.

In Gaggenau's accessories catalogue, customers can select the type of duct appropriate to their needs, whether aluflex pipe, round duct or a flat duct system. Depending on the duct type, they can choose from the nominal sizes DN 150 and DN 200. For maximum output with minimal noise, the diameter should always be as large as possible.

For straight ducting, the use of plastic or metal ducts with smooth, level inner surfaces is recommended. These enable a laminar flow of air during extraction, without air turbulence. For sections that are not straight and for bends, aluflex pipe are preferred because they make it possible to avoid hard edges.

Where space limitations are a concern, the first choice is the Gaggenau flat duct system. The remarkable design with special conducting fins in the bends and junction pieces allow for a very low height and large nominal size, thus ensuring very efficient air circulation. This also applies in situations where there are many bends. We strongly discourage the use of other flat ducts due to the high output losses in duct bends, duct corners and junction pieces.

Spiral and corrugated ducts should definitely not be used. In addition to displaying the worst flow conditions, these types also tend to flutter and thus generate noise.

The duct diameter.

A good guideline here is: The duct diameter should be as large and constant as possible, while the ducting should be as short and straight as possible. The wall outlet must correspond to the duct diameter.

AD 852 010
Flat duct
Plastic
DN 150 flat
Length 1000 mm

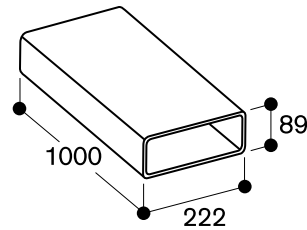

AD 852 040
Flat duct pipe connector
Plastic
DN 150 flat

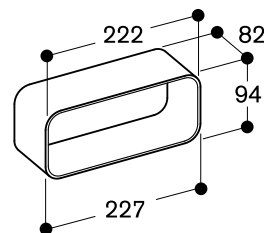

Planning notes

Flat duct pipe connector necessary for: Combination of 2 flat ducts and direct connection of flat duct to AD 854 046 and AD 854 048, also direct connection remote fan AR 403.

AD 852 030
Flat duct bend 90° vertical
Plastic
DN 150 flat

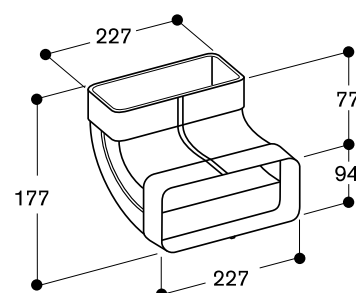

Planning notes

For connecting 2 duct bends together (e.g. 90° horizontal duct bend and a 90° vertical duct bend), a piece of flat duct is required, which can be shortened to the required length by cutting it to size.

AD 852 031

Flat duct bend 90° horizontal
Plastic
DN 150 flat

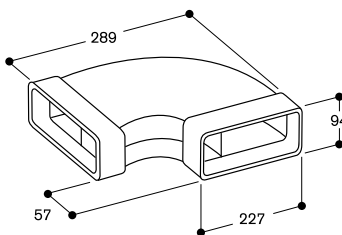

Planning notes

For connecting 2 duct bends together (e.g. 90° horizontal duct bend and a 90° vertical duct bend), a piece of flat duct is required, which can be shortened to the required length by cutting it to size.

AD 853 010

Flat duct system flex pipe
Plastic
DN 150 flat
Length: 1000 mm

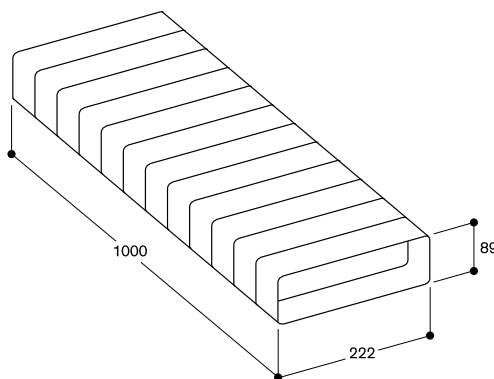

Planning notes

Recommended for the combination with the air collector box AD 704 049 and AL 400 downwards.

AD 852 042

Flat duct adapter round 90°
Plastic
DN 150 flat

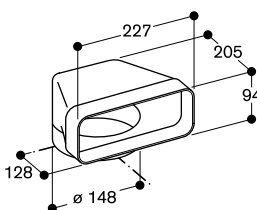

Planning notes

Direct connection to aluflex pipe.

AD 852 041

Flat duct adapter round
Plastic
DN 150 flat

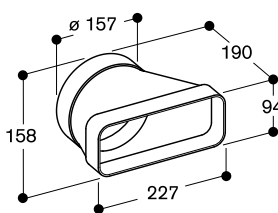

Planning notes

Connection to the round adapter of a remote fan unit or wall box. In combination with aluflex pipe, the pipe connector RV is necessary.

AD 854 045

Connecting piece
AL 400 for flat duct, 2 x DN 150
Metal zinc plated
DN 150 flat

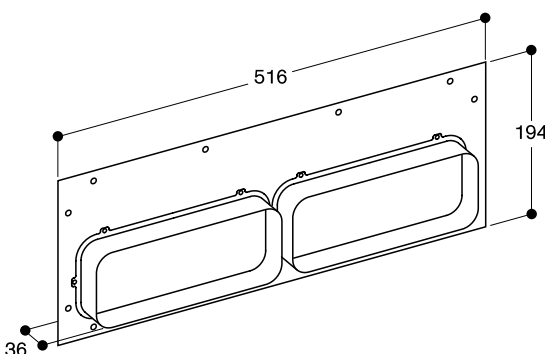

AD 854 045

Planning notes

Can be fitted on the front or back side of the AL 400.

Accessories | special accessories for ventilation appliances

AD 854 043

Connecting piece
AL 400 for flat duct, 2 x DN 150
Metal zinc plated
DN 150 flat



Planning notes

Can be fitted on the underside of the AL 400.
Set of two.

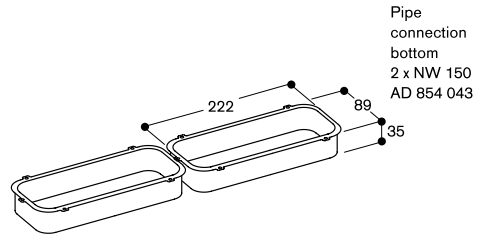

AD 854 046

Flat duct connecting piece for VL 414
Metal zinc plated with plastic
DN 150 flat



Planning notes

One piece needed for each VL 414 to be connected to flat ducts.
Outlet to the left/right possible.

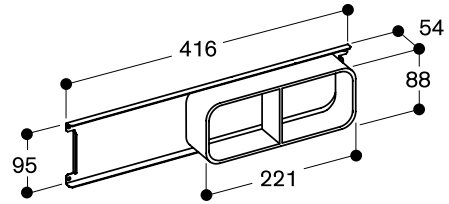

Ventilation moulding

AA 414 010

Ventilation moulding for VL 414 next to gas appliance.



Ventilation moulding

LS 041 001

Ventilation moulding for VL 200 next to gas appliance.



AD 410 040

Flexible connecting piece for VL 200
DN 150 flat

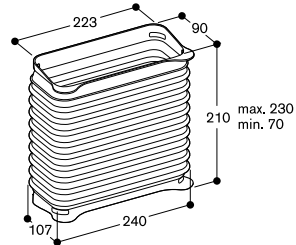

AD 851 041

Connecting piece VL 200 for extension with flat duct DN 150 for extra deep worktop

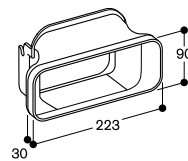

AA 010 410

Air exhaust grill air recirculation
Stainless steel-coloured, 90 cm,
including installation fittings, height
adjustable.

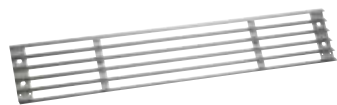

AA 409 401

Furniture support for table ventilation
AL 400 90 cm
Can be combined with table ventilation
AL 400.
Recommended as bearer for the
worktop, instead of a cabinet frame.



AA 409 431

Furniture support for table ventilation
AL 400 120 cm
Can be combined with table ventilation
AL 400.
Recommended as bearer for the
worktop, instead of a cabinet frame.



Accessories | special accessories for ventilation appliances

AD 751 010
Aluflex pipe
Aluminium
DN 150 round



Planning notes

Recommended only for routing ducting through air paths which are not in a straight line or for round wall and floor apertures. 2 hose clamps enclosed. For combination with all adapters, press the pipe wall flat at the ends. 2 aluflex pipes must be connected with a pipe connection piece for aluflex pipes.

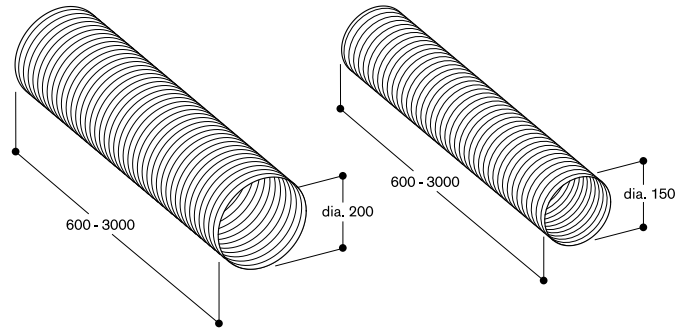

AD 702 042
Pipe adapter for small diameter
Metal zinc plated/plastic
DN 200 round

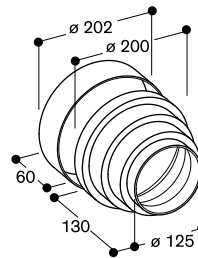

AD 754 045
Connecting piece AL 400 for
aluflex pipe, 2 x DN 150 round
Metal zinc plated
DN 150 round

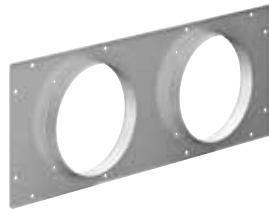

Planning notes

Can be fitted on the front or back of the AL 400.

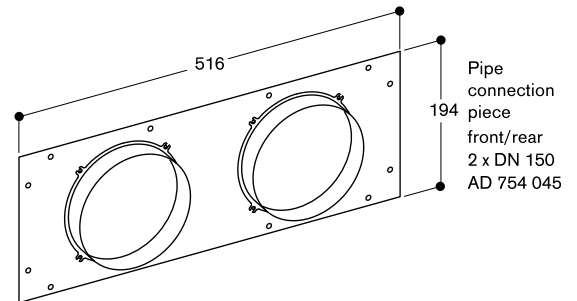

AD 724 042
Connection piece for round pipe
DN 150



Planning notes

For VL 414
For installation to left or right side of VL additional adapter AD 724 041 is necessary.

AD 724 041
Round duct connection
additional adaptor for
VL 414 on the side
Metal zinc plated
DN 150 round



Planning notes

One piece needed for each VL to be connected to round ducts DN 150 to the left/right.

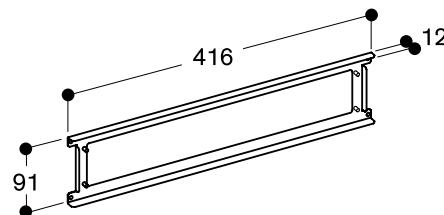

AD 990 090

Adhesive tape for duct components
Plastic
10 m/roll



Planning notes

In order that ducting is well sealed and air leaks are consequently prevented, the adhesive tape AD 990 090 is necessary at all pipe connection piece points. The adhesive tape is heat- and UV-resistant.

AD 704 048

Air collector box round duct for AL 400
Metal zinc plated
DN 150 round

Planning notes

2 x DN 150 round duct air intake.
To connect 1 x AL 400 to AR 403/413.
1 x DN 200 air outlet.

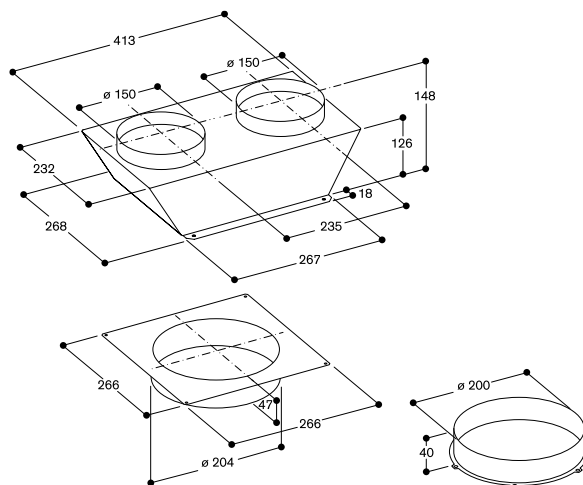

AD 704 049

Air collector flat duct for AL 400
Metal zinc plated
DN 150 flat

Planning notes

2 x DN 150 flat duct air intake
To connect 1 x AL 400 to remote fan AR 403 / AR 413 bottom side.
To connect the AL 400 and the remote fan AR 403 / AR 413 the flex duct AD 853 010 is possible and can be shortened to the appropriate length.
The package includes four cable straps for fixing the flex duct AD 853 010.

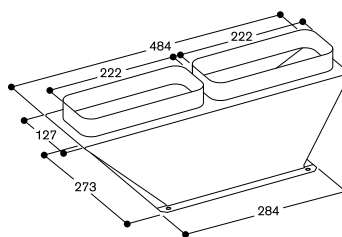



The cooling appliances

Vario cooling 400 series	144
Wine climate cabinet 400 series	147
Wine climate cabinet 200 series	148
Vario cooling 200 series	149
Overview – niche requirements	150
Planning notes	152
Additional planning notes Vario cooling 400 series	156
Accessories special accessories	160



R Y 492 504

With fresh cooling close to 0 °C
Fully integrated
Niche width 91.4 cm,
Niche height 213.4 cm
Cooling section with two doors and
one fully extendable freezing drawer

Included in the price

1 egg holder with lid
1 ice cube scoop

Installation accessories

RA 421 912

Stainless steel door panels
with handles
For RY 492, panel thickness 19 mm.

RA 423 340

Side trims, 2 pieces, for RY and RB.

RA 425 910

Handle bar, stainless steel, short
For RB/R Y 492, with 2 mounts, length
810 mm, drilling distance between the
mounts 787 mm.

RA 428 912

Stainless steel door panels, handleless
For RY 492, panel thickness 19 mm.

RA 460 000

Accessory for side-by-side installation.
Required if appliances are installed
handle to handle. Not required if
appliances are installed more than
160 mm apart from each other.
Included in delivery for RF and RW.

RA 460 013

Additional side heating element 230 V.
Required if appliances are installed
handle to hinge or hinge to hinge. Not
required if appliances are installed
more than 160 mm apart from each
other.

RA 460 030

Connecting element for vertically split
fronts (for fridge-freezer combination).

RA 464 910

Ventilation grill stainless steel
For RB/R Y 492.

Special accessories

RA 430 100

Storage container with transparent lid,
anthracite

Vario fridge-freezer combination

400 series

R Y 492

- Stainless steel interior with solid anthracite aluminium elements
- Warm white and glare-free LED light spots
- Opening assist for door with two options:
 1. Push-to-open function for integration into handleless furniture front
 2. Pull-to-open function to facilitate opening the door using a handle
- Flat stainless steel inner doors
- Almost invisible rail system for shelves and door racks for flexible positioning
- Solid anthracite aluminium door racks
- One fresh cooling drawer close to 0 °C with manually adjustable temperature and one fresh cooling drawer with manually adjustable humidity
- Integrated ice maker with fixed inlet water connection
- One asymmetrically split glass shelf, height adjustable
- Fully extendable freezer drawer with practical divider in anthracite
- TFT touch display
- Net volume 518 litres

Handling

TFT touch display operation.
Clear text display.

Technical Features

Dynamic cold air distribution.
Automatic defrosting with defrost water evaporation.
Activated charcoal air filter.
Rest mode certified by Star-K.
When rest mode is active, the appliance can only be opened using a handle.
Open-door and malfunction alarm.
Home network integration for digital services (Home Connect) either via cable connection LAN (recommended) or wireless via WiFi. The use of the Home Connect functionality is not yet available in Australia. For further information please check: home-connect.com

Cooling

No-Frost technology with fast cooling.
Temperature adjustable from +2 °C to +8 °C.
3 safety glass shelves, white glass, 2 of which are individually adjustable in height.
1 asymmetrically split safety glass shelf, with manual height adjustment.
4 brilliant LED light spots with warm white, glare-free light within cooling area and drawers.
Flat door rail system with fully flexible positioning of door racks.
6 height-adjustable door racks, 2 of which are extra deep.
Net volume 344 litres.

Fresh cooling close to 0 °C

1 fully extendable fresh cooling drawer close to 0 °C with transparent front, illuminated.
Temperature can be adjusted manually.
Ideal for meat, fish and poultry.
Net volume 34 litres.

Fresh cooling

1 fully extendable fresh cooling drawer with transparent front, illuminated.
Humidity can be adjusted manually.
Ideal for fruit and vegetables.

Freezing

No-frost technology with fast freezing at -30 °C.
Temperature adjustable from -16 °C to -24 °C.
4 star freezer compartment.
Freezing capacity 16 kg/24 h.
Storage time after a malfunction 17 h.
2 fully extendable drawers.
Interior lighting with 2 LED light spots, warm white light.
Net volume 140 litres.

Ice maker

Integrated in the freezer compartment, with fixed inlet water connection.
Particle filter for water inlet, integrated in ventilation grill area.
Can be switched off.
Ice cube production approx. 1.7 kg/24 h.
Removable ice storage container with approx. 3 kg capacity.

Consumption data

3.5 star energy rating with 436 kWh per year
Noise level 42 dB (re 1 pW).

Planning notes

Flat hinge.
Door opening angle of 115°, fixable at 90°.
Max. door panel weight:
Each door 67 kg.
Drawer 10 kg.
Shut-off valve for water connection must be planned next to the appliance and always be accessible.
If the water pressure exceeds 0.8 MPa (8 bar), connect pressure relief valve between water tap and hose set.

Please read additional planning notes on page 150–157.

Connection

Total connected load 0.574 kW.
Connecting cable 3.0 m, detachable.
Water inlet.
Supply hose 2.0 m with 3/4" connection.
Water pressure 2 to 8 bar.

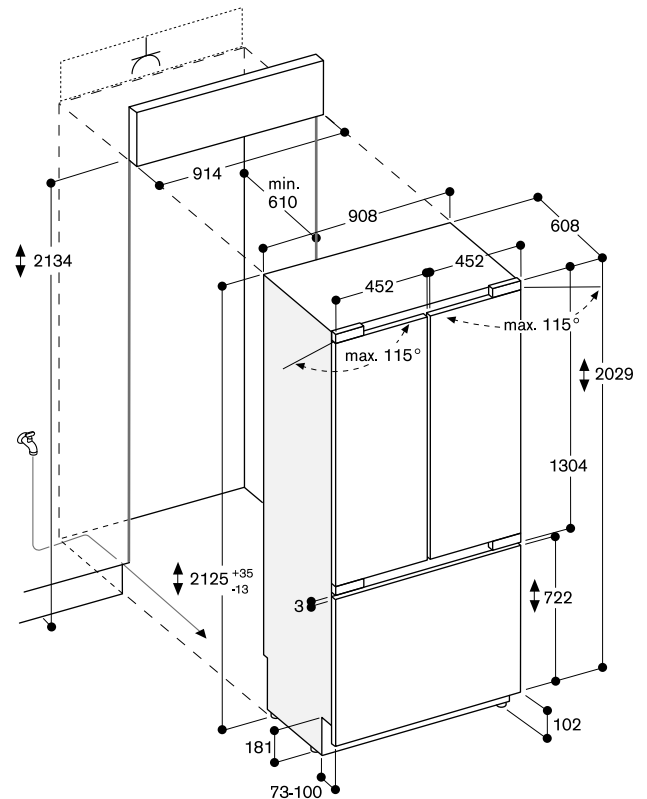

The maximum door panel dimensions are based on a clearance of 3 mm.

**RC 462 504**

With fresh cooling 0 °C
Fully integrated
Niche width 61 cm,
Niche height 213.4 cm

Included in the price

1 egg holder with lid

Installation accessories**RA 421 610**

Stainless steel door panel with handle
For 61 cm wide appliances, panel
thickness 19 mm.

RA 423 140

Side trims, long.

RA 425 110

Handle bar, stainless steel, long
With 3 mounts, length 1131 mm,
drilling distance between each mount
554 mm.

RA 428 610

Stainless steel door panel, handleless
For 61 cm wide appliances, panel
thickness 19 mm.

RA 460 000

Accessory for side-by-side installation.
Required if appliances are installed
handle to handle. Not required if
appliances are installed more than
160 mm apart from each other.
Included in delivery for RF and RW.

RA 460 013

Additional side heating element 230V.
Required if appliances are installed
handle to hinge or hinge to hinge. Not
required if appliances are installed
more than 160 mm apart from each
other.

RA 460 020

Connecting element for vertically split
appliance fronts (for a flush front).

RA 464 611

Ventilation grill stainless steel
For 61 cm wide appliances.

Special accessories**RA 430 100**

Storage container with transparent lid,
anthracite

Vario refrigerator 400 series**RC 462**

- Stainless steel interior with solid anthracite aluminium elements
- Warm white and glare-free LED light spots
- Opening assist for door with two options:
 1. Push-to-open function for integration into handleless furniture front
 2. Pull-to-open function to facilitate opening the door using a handle
- The drawers in the RC and RF models are positioned at the same height. With side-by-side installation, the glass shelves and door racks can be aligned on the same level
- Flat stainless steel inner door, full-length
- Almost invisible rail system for shelves and door racks for flexible positioning
- Solid anthracite aluminium door racks
- One fresh cooling drawer 0 °C with temperature control from -1 °C to +3 °C and one fresh cooling drawer with manually adjustable humidity
- TFT touch display
- Net volume 356 litres

Handling

TFT touch display operation.
Clear text display.

Technical Features

Dynamic cold air distribution.
Automatic defrosting with defrost water evaporation.
Activated charcoal air filter.
Rest mode certified by Star-K.
When rest mode is active, the appliance can only be opened using a handle.
Open-door and malfunction alarm.
Home network integration for digital services (Home Connect) either via cable connection LAN (recommended) or wireless via WiFi. The use of the Home Connect functionality is not yet available in Australia. For further information please check: home-connect.com

Cooling

No-Frost technology with fast cooling.
Temperature adjustable from +2 °C to +8 °C.
4 safety glass shelves, white glass, 3 of which are individually adjustable in height.
1 shallow, fully extendable drawer with transparent front.
4 brilliant LED light spots with warm white, glare-free light within cooling area and drawers.
Flat door rail system with fully flexible positioning of door racks.
3 height adjustable door racks, 1 of which is extra deep.
Net volume 321 litres.

Fresh cooling 0 °C

1 large, fully extendable fresh cooling 0 °C drawer with transparent front, illuminated.
Temperature control via central TFT display, temperature can be adjusted from -1 °C to +3 °C.
Ideal for meat, fish and poultry.
Net volume 35 litres.

Fresh cooling

1 fully extendable fresh cooling drawer with transparent front, illuminated.
Humidity can be adjusted manually.
Ideal for fruit and vegetables.

Consumption data

3.5 star energy rating with 224 kWh per year
Noise level 40 dB (re 1 pW).

Planning notes

Flat hinge.
Door hinge right, reversible.
Door opening angle of 115°, fixable at 90°.
Max. door panel weight 41 kg.

Please read additional planning notes on page 150–157.

Connection

Total connected load 0.266 kW.
Connecting cable 3.0 m, detachable.

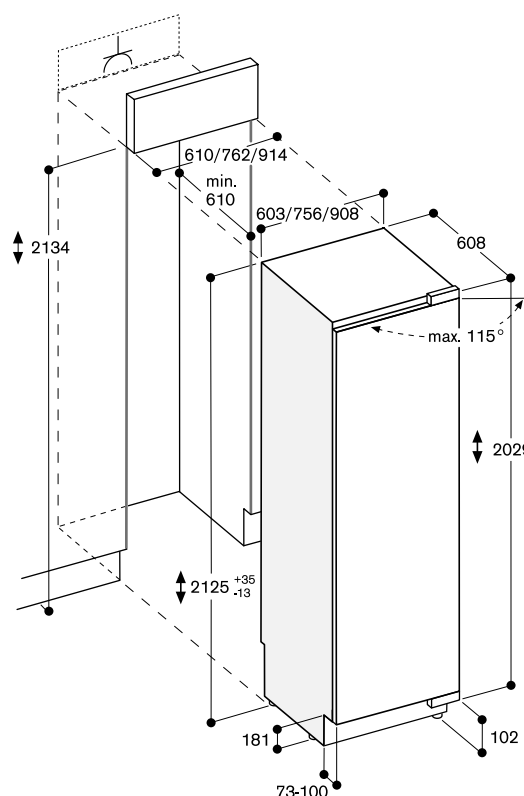

The maximum door panel dimensions are based on a clearance of 3 mm.



RF 463 505

Fully integrated
Niche width 61 cm, Niche height
213.4 cm
Left-hinged

Included in the price

Accessory for side-by-side installation

Installation accessories

RA 422 610

Stainless steel door panel with handle
For RF463, panel thickness 19 mm.

RA 423 140

Side trims, long.

RA 425 110

Handle bar, stainless steel, long
With 3 mounts, length 1131 mm,
drilling distance between each mount
554 mm.

RA 428 810

Stainless steel door panel, handleless
For RF463, panel thickness 19 mm.

RA 460 000

Accessory for side-by-side installation.
Required if appliances are installed
handle to handle. Not required if
appliances are installed more than
160mm apart from each other.

Included in delivery for RF and RW.

RA 460 013

Additional side heating element 230 V.
Required if appliances are installed
handle to hinge or hinge to hinge.
Not required if appliances are
installed more than 160 mm apart
from each other.

RA 460 020

Connecting element for vertically split
appliance fronts (for a flush front).

RA 464 614

Ventilation grill stainless steel
For RF 463, with filter, left-hinged.

Special accessories

RA 450 000

Mechanical particle filter.

Vario freezer 400 series

RF 463

- Stainless steel interior with solid anthracite aluminium elements
- Warm white and glare-free LED light spots
- Opening assist for door with two options:
 1. Push-to-open function for integration into handleless furniture front
 2. Pull-to-open function to facilitate opening the door using a handle
- The drawers in the RC and RF models are positioned at the same height. With side-by-side installation, the glass shelves and door racks can be aligned on the same level
- Material and aesthetics of interior as for RC model
 - Glass shelves
 - Solid anthracite aluminium door racks
- Flat stainless steel inner door, full-length
- Almost invisible rail system for shelves and door racks for flexible positioning
- Ice and water dispenser in the door
- Integrated ice maker with fixed inlet water connection
- Proximity sensor for ice and water dispenser
- Illuminated dispenser for ice cubes, crushed ice and chilled water
- TFT touch display
- Net volume 300 litres

Handling

TFT touch display operation.
Clear text display.
Touch key operation for ice and water dispenser.

Technical Features

Dynamic cold air distribution.
Automatic defrosting with defrost water evaporation.
Rest mode certified by Star-K. When rest mode is active, the appliance can only be opened using a handle.
Open-door and malfunction alarm.
Home network integration for digital services (Home Connect) either via cable connection LAN (recommended) or wireless via WiFi. The use of the Home Connect functionality is not yet available in Australia. For further information please check: home-connect.com

Freezing

No-frost technology with fast freezing at -30 °C.
Temperature adjustable from -16 °C to -24 °C.
4 star freezer compartment.
Freezing capacity 14 kg/24 h.
Storage time after a malfunction 10 h.
4 safety glass shelves, white glass, 2 of which are individually height adjustable.
2 fully extendable drawers with transparent front.
Brilliant LED light spots with warm white, glare-free light.

Ice and water dispenser

Warm white LED lighting.
Proximity sensor for automatic activation of light and touch keys for ice and water dispenser.
Integrated, with fixed inlet water connection.
Particle filter for water inlet, integrated in ventilation grill area.
Can be switched off.
Ice cube production approx. 1.9kg/24 h.
Ice cubes and crushed ice.
Removable ice storage container with approx. 3 kg capacity.
Ice water supply approx. 1.5 litres.

Consumption data

3.5 star energy rating with 353 kWh per year
Noise level 42 dB (re 1 pW).

Planning notes

Flat hinge.
Door opening angle of 115°, fixable at 90°.
Max. door panel weight 67 kg.
Shut-off valve for water connection must be planned next to the appliance and always be accessible.
If the water pressure exceeds 0.8 MPa (8 bar), connect pressure relief valve between water tap and hose set.

Please read additional planning notes on page 150–157.

Connection

Total connected load 0.592 kW.
Connecting cable 3.0 m, detachable.
Water inlet.
Supply hose 2.0 m with 3/4" connection.
Water pressure 2 to 8 bar.

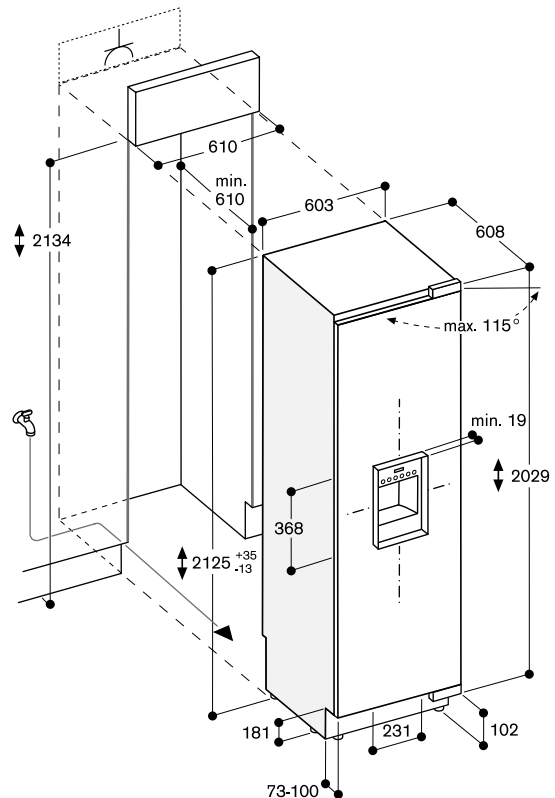

The maximum door panel dimensions are based on a clearance of 3 mm.

**RW 466 364**

Fully integrated, with glass door
Niche width 61 cm,
Niche height 213.4 cm

Installation accessories**RA 420 010**

Door lock for RW 414 and RW 464.

RA 421 611

Stainless steel door panel frame with handle

For 61 cm wide appliances, left-hinged, panel thickness 19 mm.

RA 421 612

Stainless steel door panel frame with handle

For 61 cm wide appliances, right-hinged, panel thickness 19 mm.

RA 423 140

Side trims, long.

RA 425 110

Handle bar, stainless steel, long
With 3 mounts, length 1131 mm,
drilling distance between each mount 554 mm.

RA 428 611

Stainless steel door panel frame, handleless

For 61 cm wide appliances, panel thickness 19 mm.

RA 460 013

Additional side heating element 230 V.
Required if appliances are installed handle to hinge or hinge to hinge.
Not required if appliances are installed more than 160 mm apart from each other.

RA 464 611

Ventilation grill stainless steel
For 61 cm wide appliances.

Special accessories**RA 430 000**

Screw shole cover set. 8 pieces.

RA 492 660

Removable shelf with oak wood frame
Suitable for decanters and open bottles.

For 61 cm wide appliances.

Vario wine climate cabinet 400 series**RW 466**

- Three independently controllable climate zones
- Consistent temperatures with exact control from +5 °C to +20 °C
- Humidity control
- Stainless steel interior
- Fully extendable bottle trays in oak wood and solid aluminium in anthracite
- Bottle trays with hidden telescopic rails
- Warm white and glare-free LED light spots
- Five preset lighting scenarios, selectable via TFT display
- Opening assist for door with two options: 1. Push-to-open function for integration into handleless furniture front 2. Pull-to-open function to facilitate opening the door using a handle
- Low-vibration operation
- TFT touch display
- Capacity 99 bottles

Handling

TFT touch display operation.
Clear text display.

Technical Features

Dynamic cold air distribution.
Automatic defrosting with defrost water evaporation.
Activated charcoal air filter.
UV-protection.
Rest mode certified by Star-K.
When rest mode is active, the appliance can only be opened using a handle.
Open-door and malfunction alarm.
Home network integration for digital services (Home Connect) either via cable connection LAN (recommended) or wireless via WiFi. The use of the Home Connect functionality is not yet available in Australia. For further information please check: home-connect.com

Features

Net volume 366 litres.
Capacity 99 bottles (based on 0.75 l standard bottles).
12 bottle trays,
- 9 fully extendable trays
- 3 suitable for storage of Magnum bottles.
Flexible interior configuration possible by adding or removing fully extendable bottle trays.
Storage of up to 12 Magnum bottles with standard tray configuration (12 bottle trays).
Space for max. 12 bottle trays.
2 brilliant LED light spots with warm white, glare-free light in each climate zone.
5 different lighting scenarios can be selected for individual wine presentation.

Consumption data

Energy consumption
171 kWh/year.
Noise level 42 dB (re 1 pW).

Bottle storage

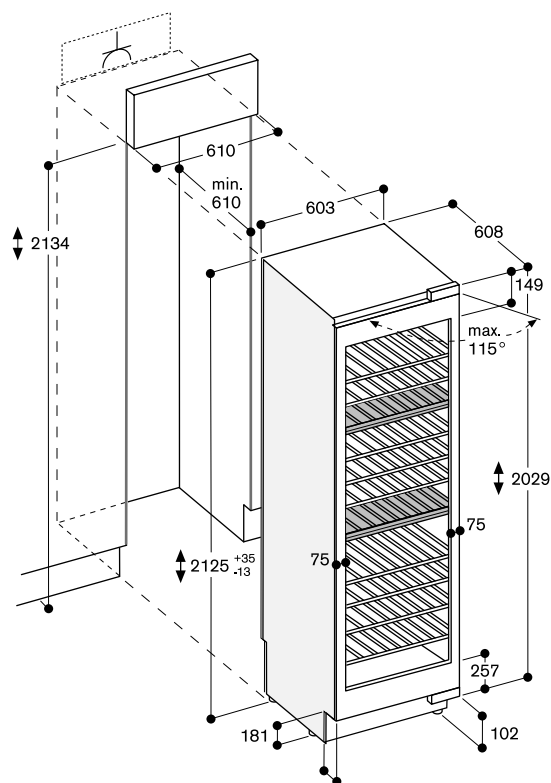
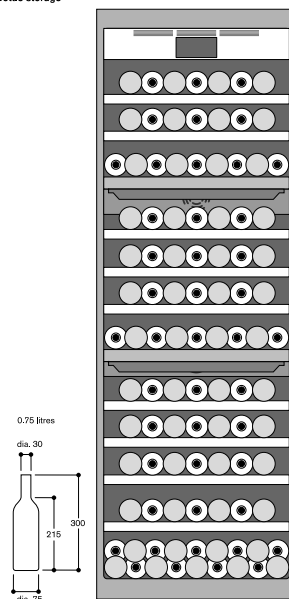

The maximum door panel dimensions are based on a clearance of 3 mm.

Planning notes

Flat hinge.
Door hinge right, reversible.
Door opening angle of 115°, fixable at 90°.
Max. door panel weight 73 kg.
The mains socket needs to be planned outside the built-in niche.
No transport/operation above 1,500 m sea level.

Please read additional planning notes on page 150–157.

Connection

Total connected load 0.131 kW.
Connecting cable 3.0 m, detachable.



RW 404 261

Under-counter, stainless steel-framed glass door
Niche width 60 cm, Niche height 82 cm

Special accessories

RA 050 220

Replacement activated charcoal air filter for RW 404.

Wine climate cabinet 200 series

RW 404

- Two independently controllable climate zones
- Consistent temperatures with exact control from +5 °C to +20 °C
- Humidity control
- Extendable bottle trays in beech and aluminium
- LED lighting
- Cushioned door closing system allowing a soft and controlled door closure
- Lockable door
- Capacity 34 bottles
- Side-by-side installation possible with special accessory

Handling

Electronic temperature control with digital display.
Touch keys.
Presentation light option in each climate zone, dimmable.
Interior lighting with automatic dimming with opening and closing of door.

Technical Features

Dynamic cold air distribution.
Automatic defrosting with defrost water evaporation.
Cushioned door closing system integrated in door hinge.
1 activated charcoal air filter for both climate zones.
UV-protection.
Open-door and malfunction alarm.
Dust filter, dishwasher-safe.

Features

Net volume 94 litres.
Capacity 34 bottles (based on 0.75 l standard bottles).
5 bottle trays, 3 of which are extendable.
Storage of magnum bottles possible.
LED lighting

Consumption data

Energy consumption 144 kwh/year.
Noise level 38 dB (re 1 pW).

Planning notes

Flat hinge.
Door hinge right, reversible.
Height-adjustable feet.
Door opening angle fixable at 95°.
For integration next to a side wall a clearance of 150 mm hinge side is necessary.
The mains socket needs to be planned outside the built-in niche.
No transport/operation above 1,500 m sea level.

Connection

Total connected load 0.13 kW.
Power requirements
220 – 240 V / 50 – 60 Hz.
Connecting cable 2.0 m with plug.

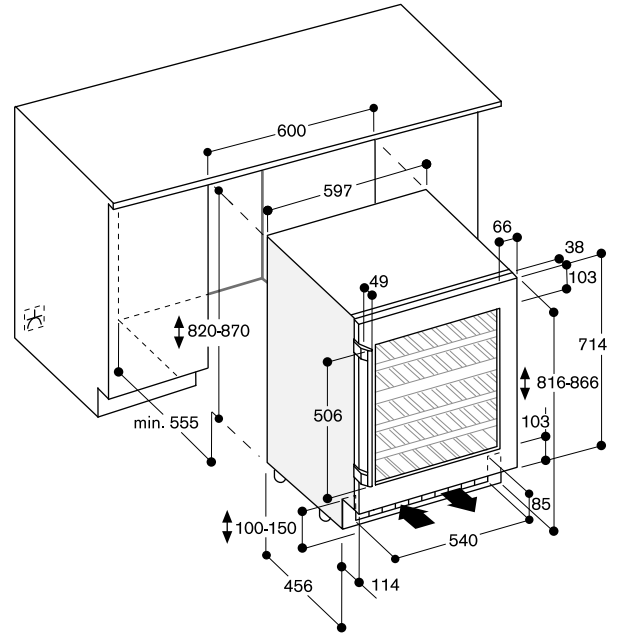

Bottle storage

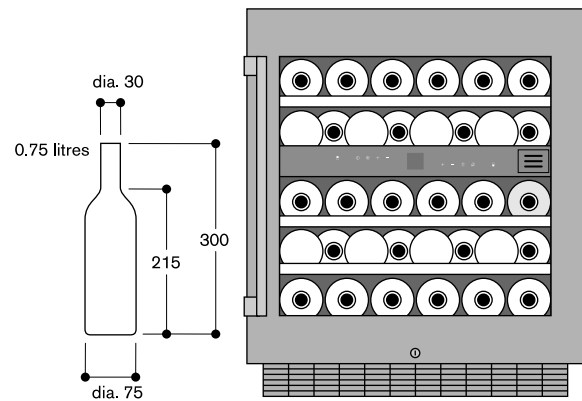

**RB 287 503**

Fully integrated
Niche width 56 cm,
Niche height 177.5 cm

Included in the price

2 cold accumulator
2 egg tray
1 wine and champagne rack
1 glass tray
1 ice cube tray
1 gastronorm insert 1/3 stainless steel
1 gastronorm lid 1/3 stainless steel

Special accessories**RA 430 100**

Storage container with transparent lid,
anthracite

Vario fridge-freezer combination**200 series****RB 287**

- Unique usage concept:
 - Maximum usage of interior: stepped shelf, full depth shelves as well as integrated fixtures for various containers
 - Easy access: fully extendable shelves and drawers
 - Optimal overview: intelligent lighting concept, use of glass and transparent materials
 - Efficient preparation, cooking and storage with Gaggenau appliances: integration of Gastronorm inserts
- Enlarged interior with 264 litre net volume through compressor relocation
- Cushioned door closing system allowing a soft and controlled door closure
- Smooth running fully extendable telescopic pull-out racks and a cushioned closing system allow a soft and controlled closure of the drawers
- 3 star energy rating

Handling

Electronic temperature control with temperature display.
Touch keys.

Technical Features

Dynamic cold air distribution.
Cushioned door closing system from 20° door opening angle, integrated in door hinge.
Open-door and malfunction alarm.

Cooling

Net volume 189 litres.
Fast cooling.
Automatic defrosting with defrost water evaporation.
Temperature adjustable from +2°C to +8°C.
3 safety glass shelves, 2 of which are height adjustable and 1 fully extendable.
Wine and champagne rack for 4 bottles, can be completely folded away.
Fixture for storing glass tray.
1 large door rack with aluminium profile for bottles with flexible bottle holder.
2 door racks with aluminium profile.
1 vegetable drawer.
Bright interior lighting with integrated glare-free side light elements.
Stepped shelf in aluminium for optimum use of interior and for storing GN inserts.
Possible combinations:
1 x 1/3 GN
2 x 1/3 GN
3 x 1/3 GN
1 x 2/3 GN
1 x 2/3 GN and 1 x 1/3 GN

Freezing

Net volume 75 litres.
No-frost technology with fast freezing.
Temperature adjustable from -16°C to -24°C.
4 star freezer compartment.
Freezing capacity 15 kg/24 h.
Storage time after a malfunction 16 h.
3 freezer drawers, 1 of which extra large.

Consumption data

3 star energy rating with 330 kWh per year.
Noise level 39 dB (re 1 pW).

Planning notes

Flat hinge.
Door hinge right, reversible.
Door opening angle of 115°, fixable at 90°.
Appliance plinth recess 90 mm.
Max. door panel weight:
Upper door 22 kg.
Lower door 22 kg.
Necessary gap between furniture door panels 4 mm.

Connection

Total connected load 0.12 kW
Power requirements
220 – 240 V / 50 Hz.
Connecting cable 1.9 m with plug.

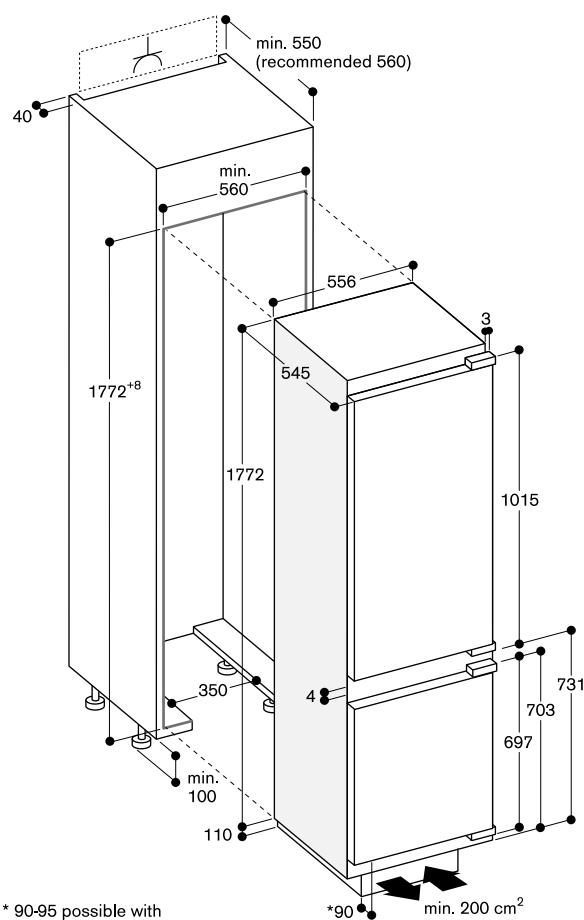

* 90° possible with
spare part: No. 11022849

Overview

Vario cooling 400 series

Niche 213 cm

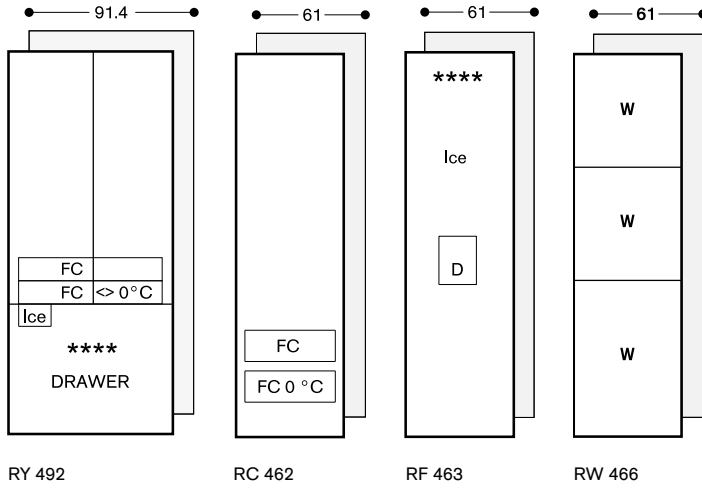

Wine climate cabinet 200 series

Niche 82 cm / Under bench

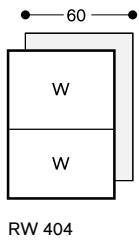

Vario cooling 200 series

Niche 178 cm

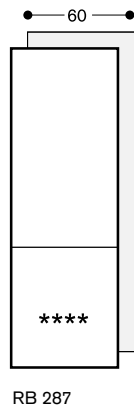

- FC:** **Fresh cooling**
- FC $\leq 0^{\circ}\text{C}$:** **Fresh cooling close to 0 °C**
- FC 0 °C:** **Fresh cooling 0 °C**
- W:** **Wine**
- D:** **Ice and water dispenser**
- Ice:** **Ice maker**



Planning principle for an individual appliance

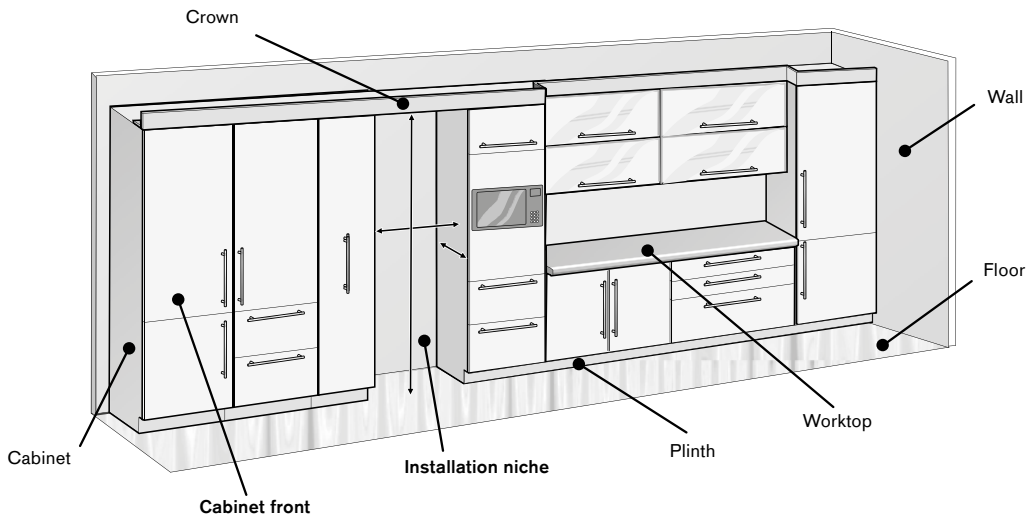

Vertical cut Installation niche

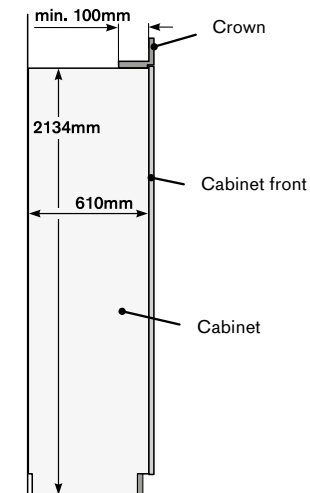

Installation niche for an individual cooling appliance (example: 610 mm wide)

In this example, the installation niche is formed by two tall cupboards (left and right) with an appropriate crown to the niche.

The cabinet door for the appliance comes in an identical design to the other kitchen fronts.

Requirements for the installation niche:

- The side walls of the installation niche must be completely even and flat along their entire depth
- Crown is at least 100 mm deep and made of a solid material (min. 16 mm thick)
- Width of the installation niche: 610 mm
- Depth of the installation niche: 610 mm

The side walls of the installation niche must be completely even and flat along their entire depth.

Horizontal cut Installation niche

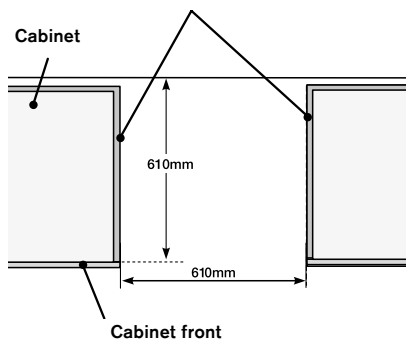

Planning principle for a side-by-side solution

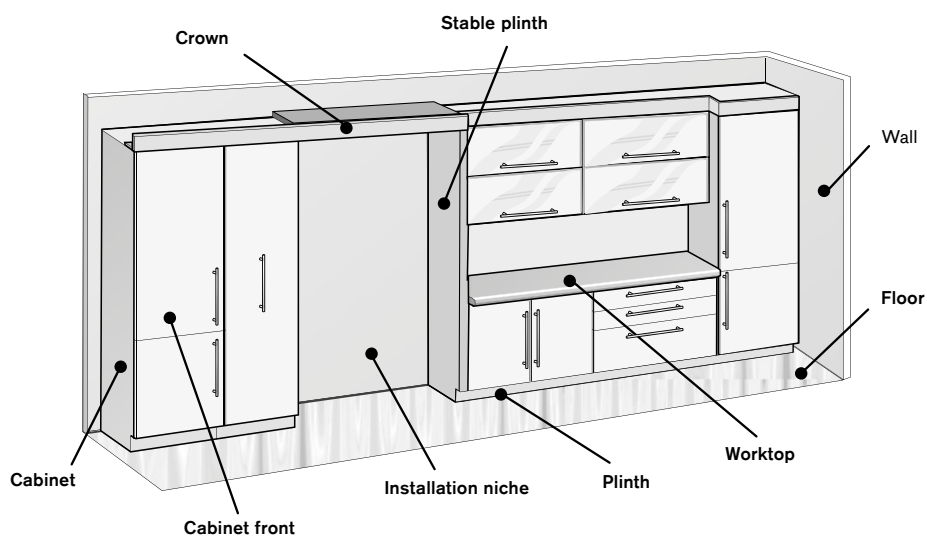

Vertical cut Installation niche

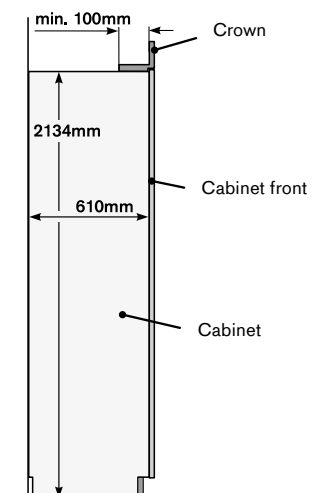

Installation niche for a side-by-side solution

- 610 mm cooling appliance (right)
- 610 mm freezer (left)

In this example, the installation niche is formed by a tall cupboard (left) and a stable plinth (right) together with an appropriate crown for the niche.

The cabinet door for both appliances comes in an identical design to the other kitchen fronts.

Requirements for the installation niche:

- The side walls of the installation niche must be completely even and flat along their entire depth
- Crown is at least 100 mm deep and made of a solid material (min. 16 mm thick)
- Width of the installation niche:
610 mm + 610 mm = 1.220 mm
- Depth of the installation niche: 610 mm

The side walls of the installation niche must be completely even and flat along their entire depth.

Horizontal cut Installation niche

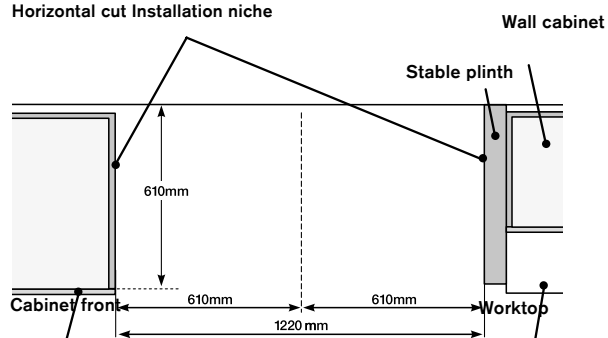

Planning examples



Side-by-side solution 1

RF 463 / RC 462

Usability limitations: No limitation.

Installation accessories: 1x RA 460 000 installation accessories for side-by-side installation (SxS)*.

Notes: Door hinges on the outside.



Side-by-side solution 2

RW 466 / RC 462

Usability limitations: No limitation.

Installation accessories: 1x RA 460 000 installation accessories for side-by-side installation (SxS)*.

Notes: Door hinges on the outside. Change door hinge of RW. If using the stainless steel fronts with a handle (installation accessories), select the correct door hinges for the RW.

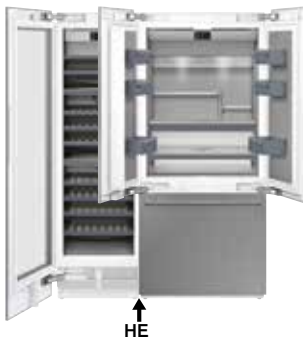

Side-by-side solution 3

RW 466 / RY 492

Usability limitations: Not all doors can be opened at the same time. The left door of the RY may collide with the handle of the RW.

Installation accessories: 1x RA 460 013 additional side heating element (HE)*.

Notes: Fitting the left RY doors at 90° is recommended. Change door hinge of RW. If using the stainless steel fronts with a handle (installation accessories), select the correct door hinges for the RW.



Combination of 3

RF 463 / RW 466 / RC 462

Usability limitations: The doors of RW and RC cannot be opened at the same time, but one after another.

Installation accessories: 1 x RA 460 000 (SxS)* – between RF and RW, 1 x RA 460 013 (HE)* – between RW and RC.

Notes: All three appliances must be connected to each other before installation and pushed together into the installation niche.



Maximum distance

RF 463 / RC 462 / RW 466 / RC 462

Usability limitations: No limitation. All doors can be opened fully.

Installation accessories: 2x RA 460 000 (SxS)*.

Notes: Two separate installation niches. Clearance is large enough to open all doors at the same time. Change door hinge of RW 466. If using the stainless steel fronts with a handle (installation accessories), select the correct door hinges for the RW.



Distance \geq 160 mm

RF 463 / RW 466 / RF 463 / RC 462

Usability limitations: The middle doors cannot be opened at the same time.

Installation accessories: 2x RA 460 000 (SxS)*.

Notes: Two separate installation niches. The clearance between the two installation niches is greater than 160 mm. If using the stainless steel fronts with a handle (installation accessories), select the correct door hinges for the RW.

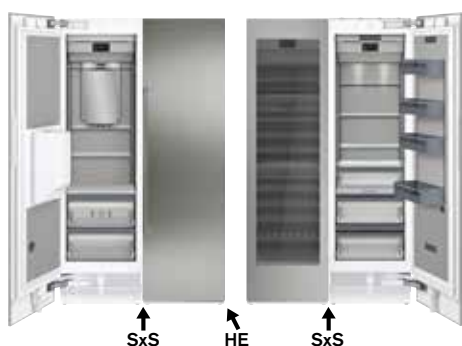

Distance \leq 160 mm

RF 463 / RC 462 / RW 466 / RC 462

Usability limitations: It may be necessary to open the middle doors one after the other, rather than at the same time.

Installation accessories: 2x RA 460 000 (SxS)*, 1x RA 460 013 (HE)*.

Notes: Two separate installation niches with a stable plinth between them. The clearance between the two installation niches is less than 160 mm. Therefore, an additional side heating element is required. Change door hinge of RW. If using the stainless steel fronts with handle (installation accessories), select the correct door hinges for the RW.



Combination of 4

RF 463 / RW 466 / RF 463 / RC 462

Usability limitations: The middle doors cannot be opened at the same time.

Installation accessories: 2x RA 460 000 (SxS)*, 1x RA 460 013 (HE)*.

Notes: All four appliances must be connected to each other before installation and pushed together into the installation niche. If using the stainless steel fronts with handle (installation accessories), select the correct door hinges for the RW.

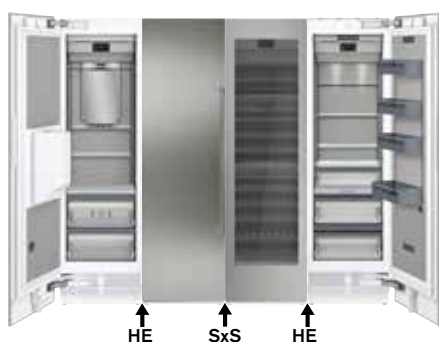

Combination of 4 - alternative

RF 463 / RC 462 / RW 466 / RC 462

Usability limitations: If the middle door is open, then neither of the outer doors can be opened.

Installation accessories: 1x RA 460 000 (SxS)* – between RC 462 and RW 466, 2x RA 460 013 (HE)* – between RF/RC and RW/RC.

Notes: The appliances in the middle are connected side-by-side. Connecting the others will require additional side heating elements. All four appliances must be connected to each other before installation and pushed together into the installation niche.

Footnote:

*SxS Accessory for side-by-side installation

*HE Additional side heating element

Additional planning notes for Vario cooling 400 series

Read the instructions in the installation manual completely and carefully before commencing installation. Installation manuals are supplied with the appliance. Installation manuals are also available at www.gaggenau.com.au

These appliances are top heavy and must be secure to prevent the possibility of tipping forward. Anti-tip protection is required.

Keep doors closed until the appliance is completely installed and secured per installation instructions.

Due to size and weight of appliance and to reduce risk of personal injury or damage to the product – **TWO PEOPLE ARE REQUIRED FOR PROPER INSTALLATION.**

Appliance must be installed by suitably trained, qualified and registered trade persons.

The side walls of the adjacent cabinetry have to be dimensionally stable, as the Vario cooling appliances are secured in the niche with only an anti-tilt bracket on the top back and on the bottom at the side.

Vario cooling appliances can be installed handle to handle as a side-by-side combination. In this case the side-by-side installation kit RA 460 000 is required. If the distance between the appliances is greater than 16 mm or less than 160 mm or the environment very humid the additional side heating element RA 460 013 needs to be installed between the appliances to avoid condensation.

If the appliances are combined hinge to handle the additional side heating element RA 460 013 is required as well. It can be omitted if the distance between the appliances is greater than 160 mm. The additional side heating element RA 460 013 does not take up any additional space. It is already included in the niche dimensions.

If the Vario cooling appliances are joined together hinge to hinge an additional stable side wall must be foreseen.

If restrictions in use are accepted (no simultaneous opening of the doors possible) the appliances can be joined together directly, using the additional side heating element RA 460 013.

When installing a Vario cooling appliance from the 400 series next to a BO/BM/BS from the ovens 400 series, a lateral distance of 60 mm is required, if the BO/BM/BS retrofitted handle is on the same side as the Vario cooling appliance door hinge. For the same installation next to a BOP/BMP/BSP from the ovens 200 series, a distance of 40 mm is required.

Door opening angle

To ensure correct kitchen planning it is essential to take into account the opening angle of the appliance door (plus fitted cabinet door and handle). There should be no possibility of collision with other kitchen furnishings (worktops, handles of other cabinetry etc.) or parts of the room (walls, protrusions etc.).

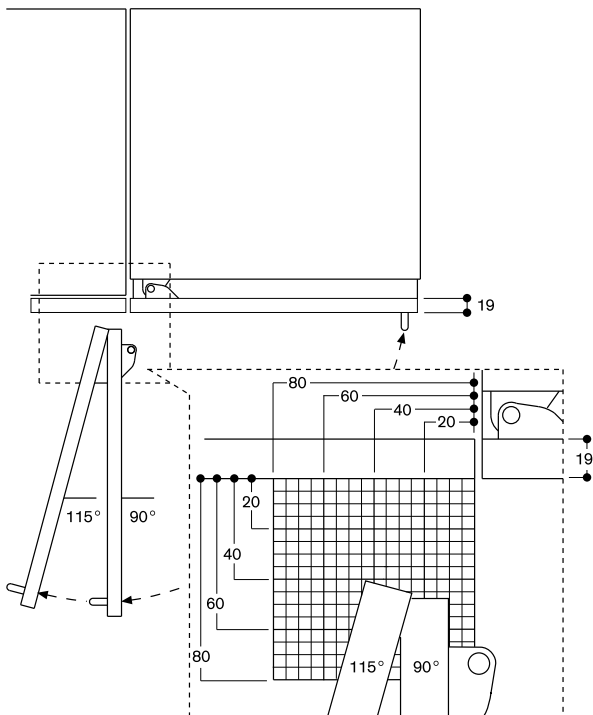

The hinge travel and resulting clearances from adjacent furniture units and handles can be found from the drawing while allowing for the thickness of the front panel. In the drawing, a furniture unit front panel thickness of 19 mm was assumed.

The space needed for the hinge and the consequential distance to the adjacent cabinetry and its handle can, depending on the panel thickness, be seen in the following drawing. The drawing assumes a panel thickness of 19 mm.

If a collision occurs, the following options are available to remedy the situation: Restrict the door opening angle to 90° (standard 115°). Pin to restrict the angle is enclosed with the appliance.

Fit a spacer between the appliance and the cabinetry that it would collide with. Rearrange surrounding cabinetry or appliance.

Wall clearance RB 492/RV 492

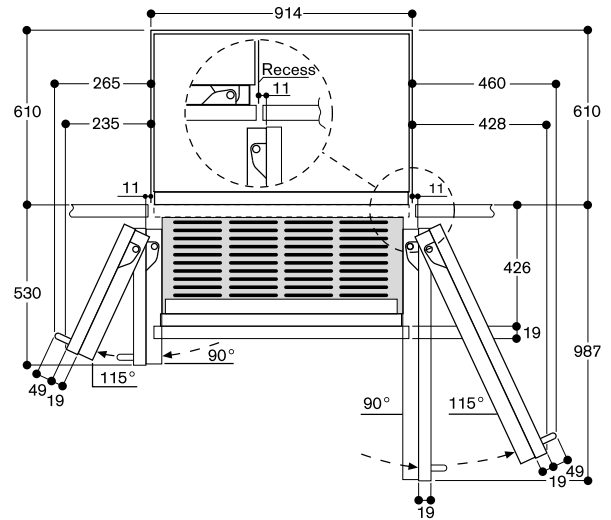

In the drawing, a unit front thickness of 19 mm and a Gaggenau unit handle of 49 mm were taken as a basis.

Wall clearance RC/RF/RW

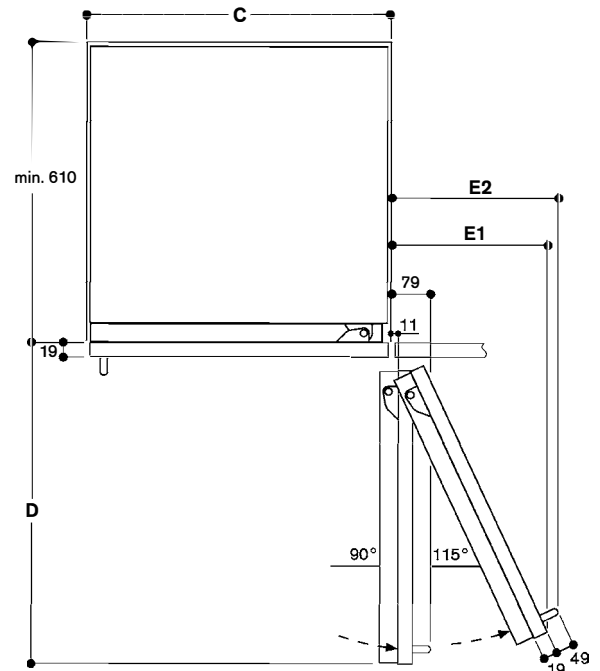

Recess width	D	E1	E2
610 mm	677 mm	299 mm	330 mm
914 mm	980 mm	428 mm	460 mm

In the drawing, a unit front thickness of 19 mm and a Gaggenau unit handle of 49 mm were taken as a basis.

Notes:

- The adjustable feet have an adjustment range of +35 mm to -13 mm. The standard height displayed in the pictures is 0 mm.
- For proper ventilation of the appliance, the clearance between the floor and bottom edge of the cabinet front must be at least 100 mm.
- The panel thickness of customised doors can range from between 19 mm and 38 mm (in the picture 19 mm).

Installation niche

Unlike conventional built-in appliances, Vario cooling appliances stand on the floor. This means that the installation niche is a space in a line of kitchen units.

Installation niche

The specified dimensions of the installation niche must be observed to guarantee the proper installation of the appliance and the design of the cabinet front. It is particularly important that the installation niche is square. The side walls must be smooth, not have any protrusions or unevenness. Use the appropriate tools, e.g. spirit level, diagonal measurements, etc. to determine whether the installation niche is square. The side walls and the crown of the installation niche must be at least 16 mm thick.

Installation niche for an individual appliance:

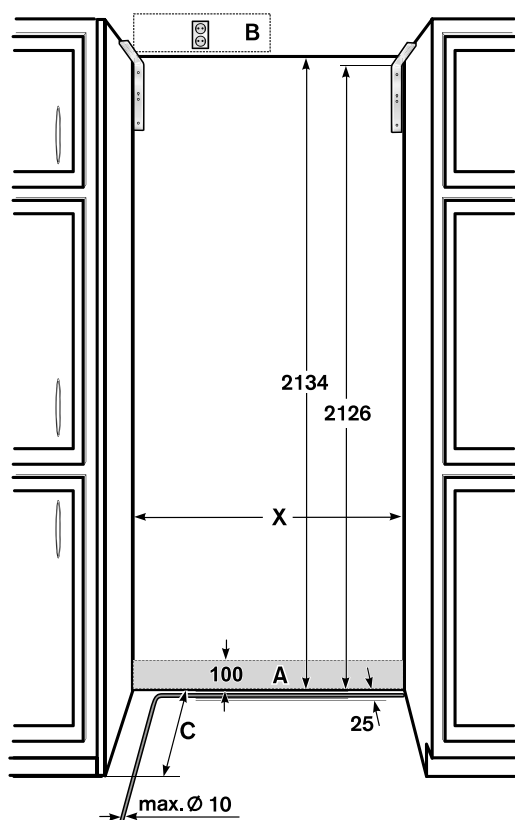

- A Area for installation the water connection
 B Area for installation the electrical connection must be outside the niche
 C Depth of installation niche, depending on kitchen design.
 C = 610 mm minimum!
 X Width of installation niche, refer to the table below for more details:

Appliance type	Width of the niche X
603 mm	610 mm
908 mm	914 mm

Installation niche for a side-by-side solution:

In a side-by-side solution, there are many ways to combine the appliances. The width of the installation niche is calculated from the sum of the widths of the individual appliances. The height and depth of the installation niche correspond to the specifications for the individual appliances. It is important to comply with the dimensions in the area set aside for electric and water connections. For the precise dimensions, please refer to the details given for individual appliances.

Location

The appliance should be installed in a dry, well ventilated room. The location of the appliance should not be subject to direct sunlight or near a source of heat, such as a cooker, a radiator, etc.

If installation next to a heat source is unavoidable, use a suitable insulating plate or observe the following minimum distances from the heat source:

- 3 cm to electric or gas cookers.
- 30 cm to an oil-fired or solid-fuel cooker.

The floor of the installation location must not give way; if required, reinforce floor.

To ensure that the ice maker functions correctly, the appliance must be upright.

Surface

To ensure that the appliance is installed securely and functions properly, the surface must be level and even.

The floor must consist of a hard, rigid material.

The floor in the installation area must have the same height as the floor in the rest of the room.

Due to the heavy weight of a fully loaded appliance, the floor beneath must be stable.

If in doubt, consult an architect, structural engineer or construction expert.

Neighbouring cabinetry

The new appliance is screwed firmly in place with the neighbouring cabinet parts.

Care should be taken to ensure that all cupboards onto which something is fastened, are connected firmly to the floor or the wall.

The thickness of the plinth can be a maximum 19 mm.

Base area | Crown of the niche

Base area

Important!

Poor ventilation leads to damage to the appliance!

Under no circumstances is it permitted to cover the air inlets and the exhaust air outlets of the appliance in the lower base area. You must observe the minimum distance of 100 mm between the upper edge of the floor and the bottom edge of the cabinet door of the appliance. Take this into consideration also when adjusting the appliance feet.

In relation to the standard height, the maximum height of the base board is 102 mm. The plinth can be maximum 19 mm thick.

Adhesive connectors are supplied on the front panel of the appliance for fitting the base board.

The air inlets and the exhaust air outlets of the appliance are located above the base board. They must not be covered.

Base detail

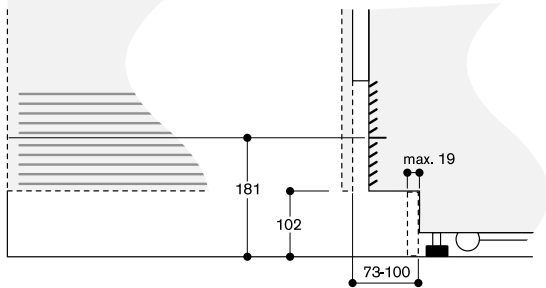

Based on the standard appliance height, the height of the plinth is 102 mm. Maximum plinth thickness 19 mm.

For design reasons, it may be necessary to increase the distance between the upper edge of the floor and the bottom edge of the cabinet door of the appliance, so that it extends beyond the standard dimension of 102 mm. The maximum dimension is 181 mm. If this is the case, air inlets and exhaust air outlets would become visible!

Crown

The height of the cabinet door on the appliance is dependent on:

- the overall height of the appliance,
- the distance from the bottom edge of the cabinet door to the floor,
- the appliance type (one-door or multi-door appliances).

The overall height of the appliance is 2.029 mm.

The height can be adjusted within a range of -13 mm to +35 mm. You must observe the minimum distance of 100 mm between the upper edge of the floor and the bottom edge of the cabinet door of the appliance.

This height can vary depending on the conditions at the site. It is possible, e.g. for design reasons, to lengthen the cabinet door upwards by extending it beyond the top of the appliance.

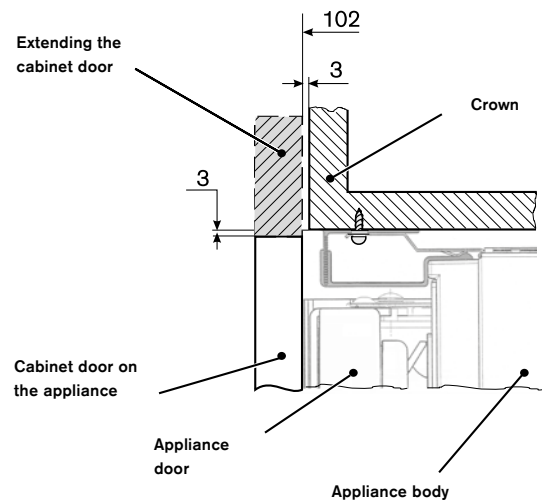

Important!

It must be ensured that the crown of the installation niche always has a depth of at least 100 mm (measured from the front edge of the appliance). Only then can the secure installation of the appliance in the installation niche be guaranteed.

Dimensions of the special accessories – door panels | door panel frames

The cabinetry, the height of the base board, the overall height of the kitchen and other determining dimensions of the kitchen must be taken into account, in order to plan the exact positioning of the cabinet door so that the appliance integrates perfectly into the overall picture of the kitchen.

The following diagrams show the basic dimensions of the special accessories door fronts/door front frames for various appliances.

The dimensions of the doors shown are designed for the following basic specifications:

- Height of the base board: 102 mm
- Overall height of the installation niche: 2.134 mm
- Gap: 3 mm
- Panel thickness: 19 mm

These specifications provide you with a good starting point for a variety of kitchen designs.

When designing a customised cabinet door, please ensure that the back of the cabinet door is visible to a height of 205 mm over the floor when opening the appliance door and adapt to the front design. All diagrams are also valid for doors without handle.

Important!

The following diagrams are not a substitute for detailed designs. Compliance with specified requirements relating to kitchen design is essential.

Recess width 45.7 cm

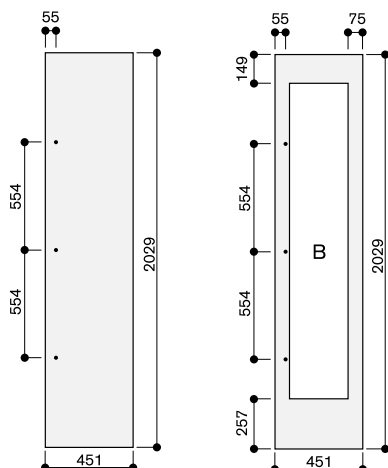

The door panel thickness is 19 mm.
The maximum door panel dimensions are based on a clearance of 3 mm, based on a single recess.
A: The cut-out for the ice and water dispenser is designed so that it is horizontally and vertically centred.
B: Width of the side frame parts of the door panel can be between 65 mm and 82 mm.

Appliance width 91.4 cm

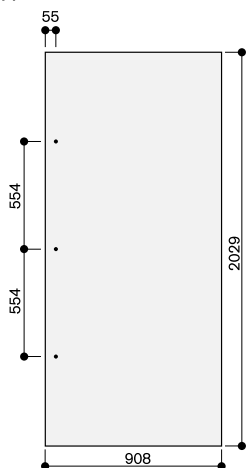

The door panel thickness is 19 mm.
The maximum door panel dimensions are based on a clearance of 3mm, based on a single recess.

Recess width 61 cm

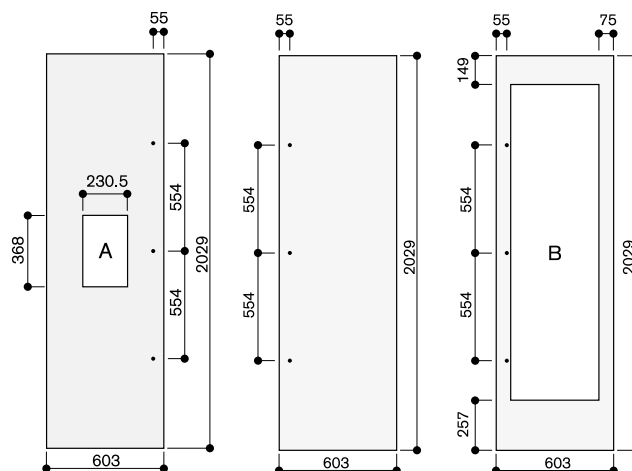

The door panel thickness is 19 mm.
The maximum door panel dimensions are based on a clearance of 3 mm, based on a single recess.
A: The cut-out for the ice and water dispenser is designed so that it is horizontally and vertically centred.
B: Width of the side frame parts of the door panel can be between 65 mm and 82 mm.

Recess width 76.2 cm

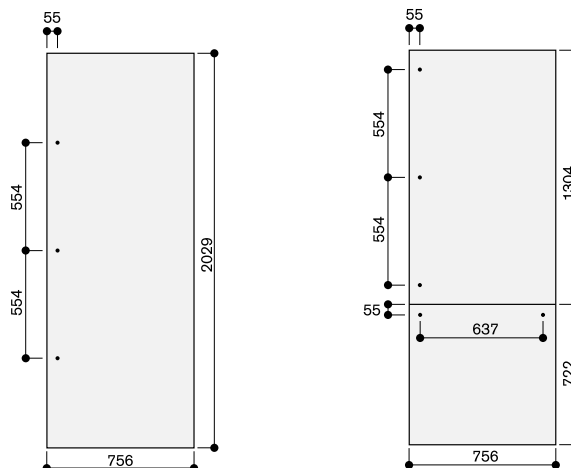

The door panel thickness is 19 mm.
The maximum door panel dimensions are based on a clearance of 3 mm, based on a single recess.

Recess width 91.4 cm

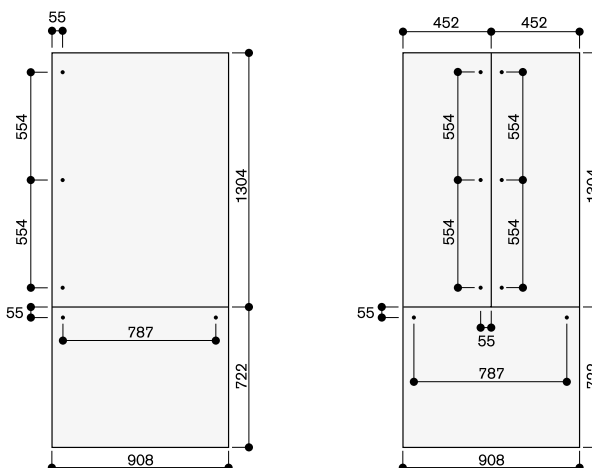

The door panel thickness is 19 mm.
The maximum door panel dimensions are based on a clearance of 3 mm, based on a single recess.

Accessories and special accessories for cooling appliances

RA 050 220

Replacement activated charcoal
air filter.



RA 430 100

Storage container with transparent lid
(anthracite).



RA 430 000

Screw shole cover set. 8 pieces
(anthracite).



RA 492 660

Removable shelf with oak wood frame
Suitable for decanters and open
bottles.
For 61 cm wide appliances.



RA 421 610

Stainless steel door panel with handle
For 61 cm wide appliances,
panel thickness 19 mm.



RA 428 610

Stainless steel door panel, handleless
For 61 cm wide appliances, panel
thickness 19 mm.



RA 421 611

Stainless steel door panel frame with
handle
For 61 cm wide appliances,
left-hinged, panel thickness 19 mm.



RA 421 612

Stainless steel door panel frame with
handle
For 61 cm wide appliances,
right-hinged, panel thickness 19 mm.



RA 428 611

Stainless steel door panel frame,
handleless
For 61 cm wide appliances, panel
thickness 19 mm.



RA 421 912

Stainless steel door panels with handles
For RY 492, panel thickness 19 mm.

**RA 425 110**

Handle bar, stainless steel, long
With 3 mounts, length 1.131 mm,
drilling distance between each
mount 554 mm.

**RA 425 910**

Handle bar, stainless steel, short
For RB/RY 492, with 2 mounts, length
810 mm, drilling distance between the
mounts 787 mm.

**RA 460 000**

Accessory for side-by-side installation

**RA 428 912**

Stainless steel door panels, handleless
For RY 492, panel thickness 19 mm.

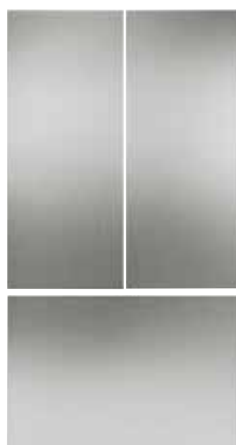
**RA 460 013**

Additional side heating element 230 V.
Required if appliances are installed
handle to hinge or hinge to hinge. Not
required if appliances are installed
more than 160 mm apart from each
other.

**RA 460 020**

Connecting element for vertically split
appliance fronts (for a flush front)

**RA 460 030**

Connecting element for vertically split
fronts (for fridge-freezer combination)

**RA 464 611**

Ventilation grill stainless steel
For 61 cm wide appliances.

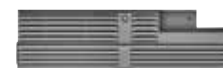
**RA 464 614**

Ventilation grill stainless steel
For RF 463, with filter, left-hinged.

**RA 464 910**

Ventilation grill stainless steel
For RB/RY 492.

**RA 422 610**

Stainless steel door panel with handle
For RF 463,
panel thickness 19 mm.

**RA 423 140**

Side trims, long.

**RA 423 340**

Side trims, 2 pieces, for RY and RB.

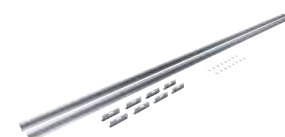
**RA 428 810**

Stainless steel door panel, handleless
For RF 463, panel thickness 19 mm.

**RA 450 000**

Mechanical particle filter
(replacement).





The dishwashers

Dishwashers 400 series	164
Dishwashers 200 series	166
Planning notes	170
Accessories special accessories	174



DF 481 561F ▲

Fully integrated
With flexible hinge
Height 86.5 cm

DF 481 562F ■

Fully integrated
With flexible hinge
Height 86.5 cm

Included in the price

- 1 baking tray spray head
- 1 GN container inserts
- 1 glass holder rack

Optional accessories

GH045010

Handle bar with 2 mounts, stainless steel, Length 45 cm, drilling distance 427 mm

Dishwasher 400 series

DF 481

- Optimal protection for sensitive glassware by low temperature drying with zeolite and intelligent water softening
- 8 programs with aqua sensor and 6 options, such as Power and Intensive:
 - Clean and dry dishes in 80 minutes
 - Intensive cleaning in the lower basket while protecting glassware in the upper basket
- Flexible basket system with smooth running rails on all levels and cushioned closing of the upper and lower basket
- TFT display for intuitive handling of all functions
- Perfectly illuminated interior
- Push-to-open function for perfect integration into handleless furniture fronts
- Quiet: 43 dB
- 14 place setting capacity
- Aqua stop with guarantee

Handling

TFT display indicating remaining or end time, refill for salt and rinsing agent, inflow of water.
Touch key operation.
Information key with use indications.
Time delay up to 24 hours.
Visual and acoustic end of program indicator.
Info-Light.

Technical Features

Perfectly illuminated interior.
Glass protection with zeolite.
Aqua sensor.
Load sensor.
Automatic detergent function.
Heat exchanger.
Continuous flow heater.
Triple filter system.
Soft lock.
Aqua stop with guarantee.

Programs

8 programs:
Auto 35 °C - 45 °C.
Auto 45 °C - 65 °C.
Auto 65 °C - 75 °C.
Intensive 70 °C.
Standard Eco 45 °C.
Night program.
Quick wash 45 °C (29 min.).
Pre-rinse.

6 options:

Intensive.
Power.
Half Load.
Hygiene.
Extra Dry.
Shine and Dry.

Features

Flexible basket system with smooth running rails on all levels and cushioned closing of the upper and lower basket.
Cutlery drawer.

Upper basket:

Over extension.
Rackmatic with 3 levels, adjustable in height up to 5 cm.
6 folding spines.
4 folding racks.
2 glass support bars.

Lower basket:

8 folding spines.
2 folding racks.
Dividable glass support.
Cutlery basket.
Holder for long-stemmed glasses.

Maximum dish sizes

(upper/lower basket)
for 86.5 cm high dishwashers: 29/28, 26.5/30.5 or 24/34 cm respectively.

14 place setting capacity.

Maximum glass loading capacity
23 wine glasses.

Consumption data

4 star energy rating with 230 kWh per year.
5 star WELS rating with 12 litres per wash on Eco 45 °C program.
Noise level 43 dB (re 1 pW).

Planning notes

Height-adjustable feet.
Appliance plinth recess 100 mm (see drawing).
Rear feet adjustable at front.
Door weight up to 10 kg.
Door panel dimension dependent on plinth height of kitchen furniture.
Installation and usage also with furniture handle possible. The push-to-open function remains active.
For installation into a tall unit, ventilation openings are recommended (min. 200 cm²).

Please read additional planning notes on page 170–173.

Connection

Total connected load 2.4 kW.
Power requirements
220 – 240 V / 50 – 60 Hz.
Connecting cable with plug.
Water connection with 3/4" screw joint.
Connection to hot or cold water possible.

DF 481 561 F

86.5 cm high dishwasher with flexible hinge

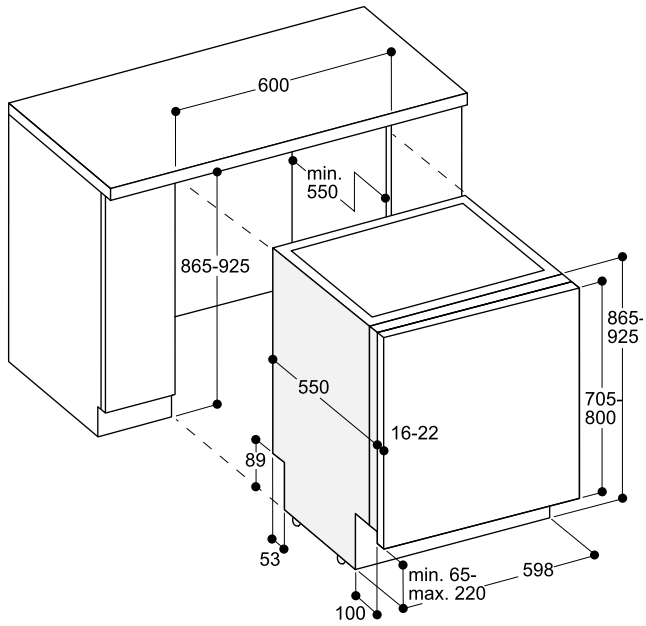

DF 481 562 F

86.5 cm high dishwasher with flexible hinge

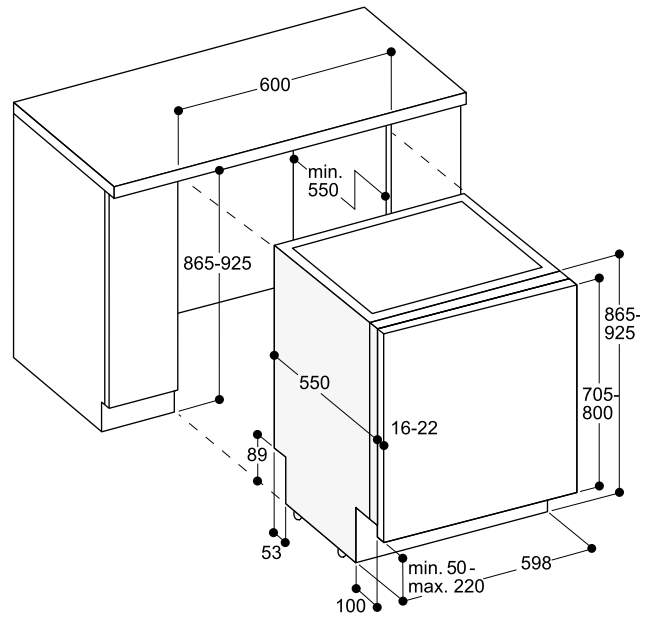

Connection dimensions for a 60 cm wide dishwasher

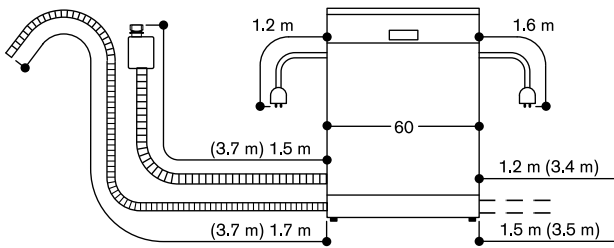

() values with extension kit



DF 250 560

Fully integrated
Height 81.5 cm

Included in the price

1 baking tray spray head

Installation accessories**GH 045 010**

Handle bar with 2 mounts, stainless steel, Length 45 cm, drilling distance 427 mm

Dishwasher 200 series**DF 250**

- 6 programs with aqua sensor and 2 options, Power and Intensive:
 - Clean and dry dishes in 80 minutes
 - Intensive cleaning in the lower basket while protecting glassware in the upper basket
- TFT display for intuitive handling of all functions
- Bright interior lighting
- Quiet: 40 dB
- 15 place setting capacity
- Aqua stop with guarantee

Handling

TFT display indicating remaining or end time, refill for salt and rinsing agent, inflow of water.
Touch key operation.
Information key with use indications.
Time delay up to 24 hours.
Visual and acoustic end of program indicator.
Info-Light.

Technical Features

Bright interior lighting.
Glass protection.
Aqua sensor.
Load sensor.
Automatic detergent function.
Heat exchanger.
Continuous flow heater.
Triple filter system.
Soft lock.
Aqua stop with guarantee.

Programs

6 programs:
Auto 35 °C - 45 °C.
Auto 45 °C - 65 °C.
Auto 65 °C - 75 °C.
Standard Eco 50 °C.
Quick wash 45 °C (29 min.).
Pre-rinse.

2 options:
Intensive.
Power.

Features

Flexible basket system.
Cutlery drawer.

Upper basket:
Rackmatic with 3 levels, adjustable in height up to 5 cm.
2 folding spines.
2 folding racks.

Lower basket:
4 folding spines.
2 folding racks.

Maximum dish sizes
(upper/lower basket)
for 81.5 cm high dishwashers: 27/25,
24.5/27.5 or 22/31 cm respectively.
15 place setting capacity.

Consumption data

4 star energy rating with 235 kWh per year.
5 star WELS rating with 12 litres per wash on Eco 45 °C program.
Noise level 44 dB (re 1 pW).

Planning notes

Height-adjustable feet.
Appliance plinth recess 100 mm (see drawing).
Rear feet adjustable at front.
Door weight up to 8.5 kg.
Door panel dimension dependent on plinth height of kitchen furniture.
For installation into a tall unit, ventilation openings are recommended (min. 200 cm²).

Please read additional planning notes on page 170–173.

Connection

Total connected load 2.4 kW.
Power requirements
220 – 240 V / 50 – 60 Hz.
Connecting cable with plug.
Water connection with 3/4" screw joint.
Connection to hot or cold water possible.

81.5 cm high dishwasher

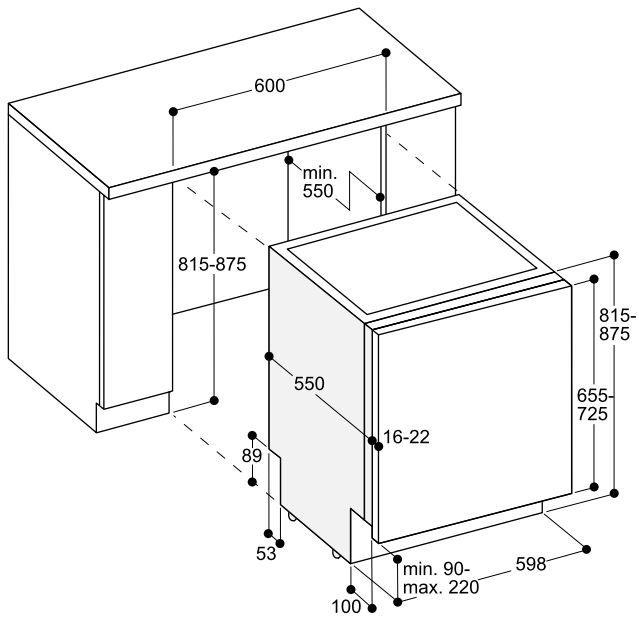

Connection dimensions for a 60 cm wide dishwasher

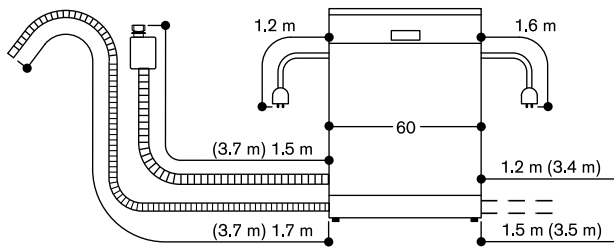

() values with extension kit



DI 261 112 ▲

Semi-integrated
Stainless steel panel
Height 86.5 cm

Included in the price

- 1 baking tray spray head
- 1 stainless steel trim kit

Installation accessories

GZ 010 011

Aqua stop extension (2 m long)
Extends the water inlet and outlet.

Special accessories

DA 041 160

Cutlery drawer with smooth running rails
3rd level above the upper basket.
For large pieces of cutlery, cooking utensils and espresso cups.
13 place setting capacity with all 3 levels.

DA 042 030

Silvercare cartridge for all dishwashers

DA 043 000

Holder for long-stemmed glasses
Offers safe positioning for up to four long-stemmed glasses during the dishwashing process and ensures an optimal cleaning result.
For positioning in the lower basket.

Dishwasher 200 series

DI 261

- Optional door opening at the end of the program to support the hygienic drying process
- 6 programs with aqua sensor and 3 options, such as Power and Intensive:
 - Clean and dry dishes in 59 minutes
 - Intensive cleaning in the lower basket while protecting glassware in the upper basket
- Flexible basket system with smooth running rails on all levels
- TFT display for intuitive handling of all functions
- Bright interior lighting
- Very quiet: 42 dB
- 12 place setting capacity
- Aqua stop with guarantee

Handling

TFT display indicating remaining or end time, refill for salt and rinsing agent, inflow of water.
Touch key operation.
Information key with use indications.
Time delay up to 24 hours.
Visual and acoustic end of program indicator.

Technical Features

Bright interior lighting.
Glass protection.
Aqua sensor.
Load sensor.
Automatic detergent function.
Regeneration electronics.
Heat exchanger.
Continuous flow heater.
Triple filter system.
Soft lock.
Aqua stop with guarantee.
Home network integration for digital services (Home Connect) either via cable connection LAN (recommended) or wireless via WiFi. The use of the Home Connect functionality is not yet available in Australia. For further information please check: home-connect.com

Programs

6 programs:
Auto 35 °C - 45 °C.
Auto 45 °C - 65 °C.
Auto 65 °C - 75 °C.
Standard Eco 50 °C.
Quick wash 45 °C (29 min.).
Pre-rinse.

3 options:

Intensive.
Power.
Holiday.

Features

Flexible basket system with smooth running rails on all levels.

Upper basket:
Over extension.
Rackmatic with 3 levels, adjustable in height up to 5 cm.
6 folding spines.
4 folding racks.
2 glass support bars.

Lower basket:
8 folding spines.
2 folding racks.
Dividable glass support.
Cutlery basket.

Maximum dish sizes
(upper/lower basket)
for 86.5 cm high dishwashers:
29/28, 26.5/30.5 or 24/34 cm respectively.

12 place setting capacity.
Maximum glass loading capacity
23 wine glasses.

Consumption data

2.5 star energy rating with 337 kWh per year.
5 star WELS rating with 9.8 litres per wash on Eco 50 °C program.
Noise level 42 dB (re 1 pW).

Planning notes

Height-adjustable feet.
Appliance plinth recess 100 mm (see drawing).
Rear feet adjustable at front.
Door weight up to 8.5 kg.
Door panel dimension dependent on plinth height of kitchen furniture.
For installation into a tall unit, ventilation openings are recommended (min. 200 cm²).

Please read additional planning notes on page 170–173.

Connection

Total connected load 2.4 kW.
Connecting cable with plug.
Water connection with 3/4" screw joint.
Connection to hot or cold water possible.

86.5 cm high dishwasher

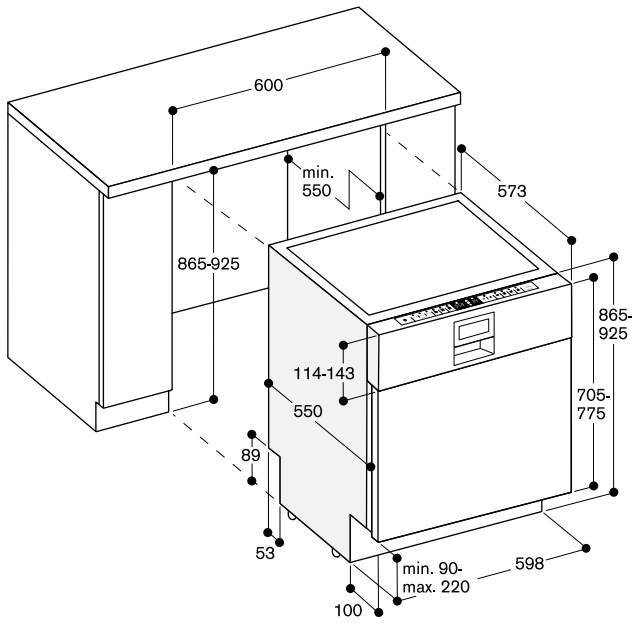

Connection dimensions for a 60 cm wide dishwasher

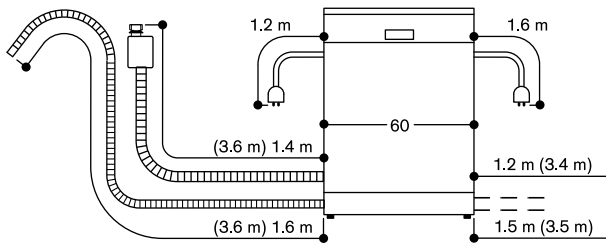

() values with extension kit

Additional planning notes for standard dishwashers (without flexible hinge)

For niche heights from 815 to 855 mm, in most cases, the 81.5 cm high dishwasher must be planned, regardless of the plinth height.

For niche heights from 885 to 925 mm, in most cases, the 86.5 cm high dishwasher must be planned, regardless of the plinth height.

If the niche height amounts to 865 or 875 mm, please note:
Whether the 81.5 cm high dishwasher or the 86.5 cm high dishwasher can be used here depends on the plinth height.

For dishwasher with remaining time projection, the maximum plinth height must be reduced by 30 mm to provide an optimal display.

Plinth height in mm	Cabinet height 655–725 mm						Cabinet height 705–775 mm					
	Niche height in mm →											
	815	825	835	845	855	865	875	885	895	905	915	925
<90	1	1	1	1	1	1 6	1 6	6	6	6	6	6
90	1	1 (D)	1	1	1	1 6	1 6 (D)	6	6	6	6	6
100	1	1	1 (D)	1	1	1 6	1 6	6 (D)	6	6	6	6
110	1	1	1	1 (D)	1	1 6	1 6	6	6 (D)	6	6	6
120	1	1	1	1	1 (D)	1 6	1 6	6	6	6 (D)	6	6
130	1	1	1	1	1	1 (D) 6	1 6	6	6	6	6 (D)	6
140	1	1	1	1	1	1 6	1 (D) 6	6	6	6	6	6 (D)
150	1	1	1	1	1	1 6	1 6	6	6	6	6	6
160	1	1	1	1	1	1 6	1 6	6	6	6	6	6
170		1	1	1	1	1	1 6	6	6	6	6	6
180			1	1	1	1	1	6	6	6	6	6
190				1	1	1	1		6	6	6	6
200					1	1	1			6	6	6
210						1	1				6	6
220							1					6

- 1 = 81.5 cm high dishwasher DF 250
- 6 = 86.5 cm high dishwasher DI 261

(D) = special solution with 10 mm gap from the worktop → Spacer batten / child lock not possible

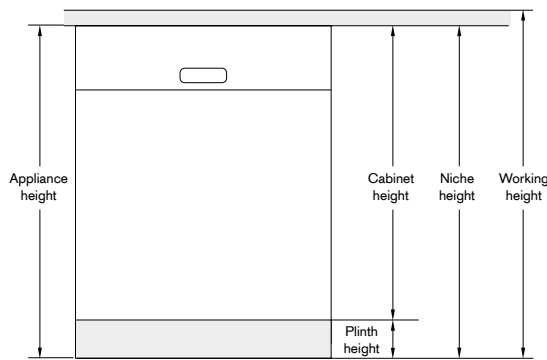

Additional planning notes for dishwashers with flexible hinge

For niche heights from 815 to 860 mm, in most cases, the 81.5 cm high dishwasher must be planned, regardless of the plinth height.

For niche heights from 880 to 925 mm, in most cases, the 86.5 cm high dishwasher must be planned, regardless of the plinth height.

If the niche height amounts between 865 and 875 mm, please note: Whether the 81.5 cm high dishwasher or the 86.5 cm high dishwasher can be used here depends on the plinth height.

If the installation of a dishwasher with **flexible hinge** is necessary or not depends on several factors.

The door panels cannot be used with dishwashers with flexible hinge.

		Front height 655–765 mm									
		Niche height in mm →									
		815	820	825	830	835	840	845	850	855	860
50	Plinth height in mm ↓	①									
55		①	①								
60		①	①	①							
65		①	①	①	①						
70		①	①	①	①	①					
75		①	①	①	①	①	①				
80		①	①	①	①	①	①	①			
85		①	①	①	①	①	①	①	①		
90		①*	①	①	①	①	①	①	①	①	
95		①*	①*	①	①	①	①	①	①	①	①
100		①*	①*	①*	①	①	①	①	①	①	①
105		①*	①*	①*	①*	①	①	①	①	①	①
110		①*	①*	①*	①*	①*	①	①	①	①	①
115		①*	①*	①*	①*	①*	①*	①	①	①	①
120		①*	①*	①*	①*	①*	①*	①*	①	①	①
125		①*	①*	①*	①*	①*	①*	①*	①*	①	①
130		①*	①*	①*	①*	①*	①*	①*	①*	①*	①
135		①*	①*	①*	①*	①*	①*	①*	①*	①*	①*
140		①*	①*	①*	①*	①*	①*	①*	①*	①*	①*
145		①*	①*	①*	①*	①*	①*	①*	①*	①*	①*
150		①*	①*	①*	①*	①*	①*	①*	①*	①*	①*
155		①*	①*	①*	①*	①*	①*	①*	①*	①*	①*
160		①*	①*	①*	①*	①*	①*	①*	①*	①*	①*
165			①*	①*	①*	①*	①*	①*	①*	①*	①*
170				①*	①*	①*	①*	①*	①*	①*	①*
175					①*	①*	①*	①*	①*	①*	①*
180						①*	①*	①*	①*	①*	①*
185							①*	①*	①*	①*	①*
190								①*	①*	①*	①*
195									①*	①*	①*
200										①*	①*
205											①*
210											
215											
220											

① = 81.5 cm high dishwasher with flexible hinge DF 480 163F / DF 260 166F

② = 86.5 cm high dishwasher with flexible hinge DF 481 163F / DF 261 166F

* Also possible with dishwashers without flexible hinge.

Overview for global range

Accessories and special accessories for dishwashers

Flexible basket system

Flexible basket system with smooth running rails on all levels and cushioned closing of the upper and lower basket.

Upper basket

For more flexibility and easier handling when loading and unloading the dishwasher.

6 folding spines.
4 folding racks.
2 glass support bars.
With over extension, smooth running rails and cushioned closing as well as rackmatic with 3 levels, adjustable in height up to 5 cm.
Handle for easier removal of the upper basket.



Lower basket

8 folding spines.
2 folding racks.
Dividable glass support.
Cutlery basket.
With smooth running rails and cushioned closing.
Handle for easier removal of the lower basket.

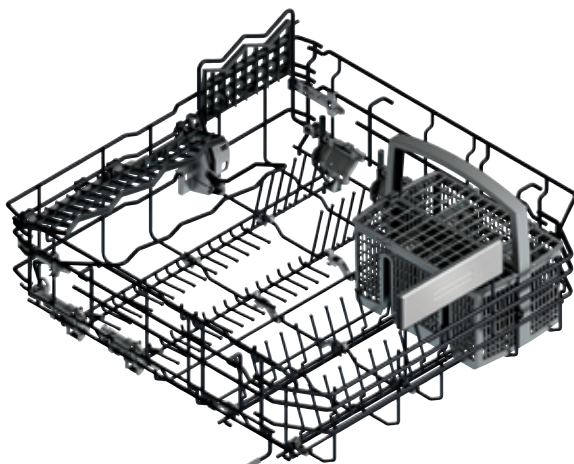

DA 041 160

Cutlery drawer with smooth running rails
3rd level above the baskets.
For large pieces of cutlery, cooking utensils and espresso cups.
13 place setting capacity with all 3 levels.



GH 045 010

Handle bar with 2 mounts, stainless steel, Length 45 cm, drilling distance 427 mm





The accessories

Gastronorm system

178

Accessories in the Gaggenau Gastronorm system

For usage in the various Gaggenau appliances the following accessories in the Gaggenau Gastronorm system are available.

Gastronorm insert

GN 144/154

These high-walled, sturdy inserts made from hygienic stainless steel are ideal for cooking with steam and equally practical for storage in the refrigerator or serving at the table. They are available both in hygienic stainless steel design as well as with non-stick coating. Both are dishwasher-safe. The non-stick coating of the Gastronorm inserts prevent adherence of food and are therefore particularly easy to clean. For practical food preparation, the inserts fit snugly into any Gastronorm sink.

GN 114 230 (Included in price for Combi-steam ovens)

Gastronorm insert, stainless steel, GN 2/3, unperforated, 40 mm deep, 3 l



GN 124 230 (Included in price for Combi-steam ovens)

Gastronorm insert, stainless steel, GN 2/3, perforated, 40 mm deep, 3 l



GN 144 230

Gastronorm insert, non-stick, GN 2/3, unperforated, 40 mm deep, 3 l



GN 154 230

Gastronorm insert, non-stick, GN 2/3, perforated, 40 mm deep, 3 l



Gastronorm lid

GN 410

The Gastronorm lid may be used to seal the Gastronorm inserts. Together they are optimal for storing and keeping fresh of food and dishes in the vario cooling 200 series appliances.

GN 410 230

Gastronorm lid, stainless steel, GN 2/3, for stainless steel gastronorm inserts



Gastronorm roaster

GN 340

Gastronorm roaster GN 2/3, height 165 mm. Non-stick coating. For roasting in the oven with the roasting function. The top and bottom parts can be used as separate ovenproof dishes (65 mm/100 mm deep). Use in ovens with pull-out system BA 018/BA 016 and heating element (order separately). Also to be used with Combi-steam ovens: slide directly into the appliance's side racks.

GN 340 230

Gastronorm roaster, cast aluminium, GN 2/3, height 165 mm



Teppan Yaki

GN 232

GN 232 110

Teppan Yaki made of multi ply material, GN 1/1
For full surface induction cooktop
CX 480



The Gaggenau Gastronorm system

The Gastronorm system provides the basis for cookware in the professional kitchen. It enables a smooth continuum from the preparation and cooking stages right through to serving at the table and storage. The Gastronorm inserts from Gaggenau have been adapted to match our Vario cooling 200 series, our Combi-steam ovens, our ovens as well as our dishwashers. Furthermore, the Gastronorm sink represents yet another valuable addition to the process chain.

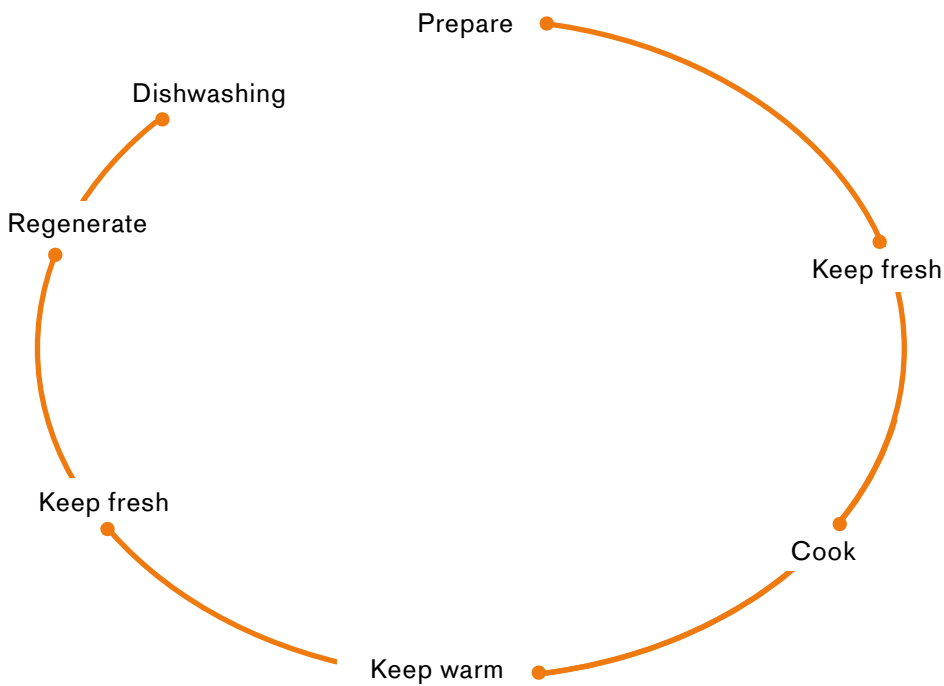

Prepare.

To prepare in combination with kitchen sinks in the Gastronorm format.

Keep fresh.

To keep fresh with appliances of the Vario cooling 200 series.

Cook.

To cook in our Combi-steam ovens BS/BSP or our ovens BO/BOP in combination with the pull-out system BA 018/BA 016.

Keep warm.

To keep warm in the Gaggenau warming drawers WS/WSP.

Regenerate/warm up.

To regenerate in our Combi-steam ovens BS/BSP, CI and CX or in our ovens BO/BOP in combination with the pull-out systems BA 018/BA 016.

Dishwashing.

Optimal cleaning and drying of the GN inserts thanks to the GN insert holder.

The difference is Gaggenau.

Gaggenau Melbourne
192-196 Coventry Street
South Melbourne
Victoria 3205
+61 3 8551 1399

Gaggenau is proudly manufactured and distributed by
BSH Home Appliances Pty Ltd.
For your Gaggenau enquiry please call 1300 170 552
or visit www.gaggenau.com.au

The information for all products is current as at the date of publication. Whilst every care has been taken in the preparation of this publication, BSH does not warrant the accuracy or completeness of the information in this publication and BSH reserves the right to alter specifications and pricing without notice. To the extent permitted by law, BSH excludes all liability, including negligence, for any loss incurred in reliance on the contents of this publication. Please note that the appearance and/or inclusions of products may change from those displayed in these materials. The appliances are for household use only.