



RF471301

RA460040:
Finger protection extra long

RA461714:
Toe kick 76,2cm/30"

RA421710:
SS door 76,2cm / 30"

RA425110:
Vario SS handle 1131 mm

RA460011:
Heating side kit 230V

RA460020:
Frontpanel connection long

Vario built-in freezer 400 series
212.5 x 75.6 cm, flat hinge
RF471301

Stainless steel interior
Generous lighting concept
Integrated ice maker with fixed inlet water connection
Solid aluminium door racks
Net volume 421 litres
Energy efficiency class A+

Handling

Electronic temperature control with digital display.

Technical Features

Dynamic cold air distribution.
Automatic defrosting with defrost water evaporation.
Open-door and malfunction alarm.

Freezing

No-frost technology with fast freezing.
4-star freezer compartment.
Freezing capacity 20 kg/24 h.
Storage time after a malfunction 14 h.
4 solid metal shelves, 3 of which are manually adjustable.
2 fully extendable drawers with transparent front, 1 of which large, 1 regular.
Bright interior lighting with light pillars.
4 height-adjustable door racks, 1 of which is extra deep.
1 door rack with transparent front flap.

Ice maker

Integrated, with fixed inlet water connection.
Can be switched off.
Ice cube production: approx. 1.4 kg/24 h.
Removable ice storage container with approx. 4 kg capacity.

Consumption data

Energy consumption 427 kWh/year.
Noise level 42 dB (re 1 pW).

Planning notes

Flat hinge.
Door hinge left, reversible.
Door opening angle of 115°, fixable at 90°.
Max. door panel weight 18 kg.
Shut-off valve for water connection must be planned next to the appliance and always be accessible.
If the water pressure exceeds 0.8 MPa (8 bar), connect pressure relief valve between water tap and hose set.

Connection

Total connected load: 0.501 KW.
Connecting cable 3.0 m, detachable.
Water inlet.
Supply hose 3.0 m with 3/4 " connection.
Water pressure 2 to 8 bar.

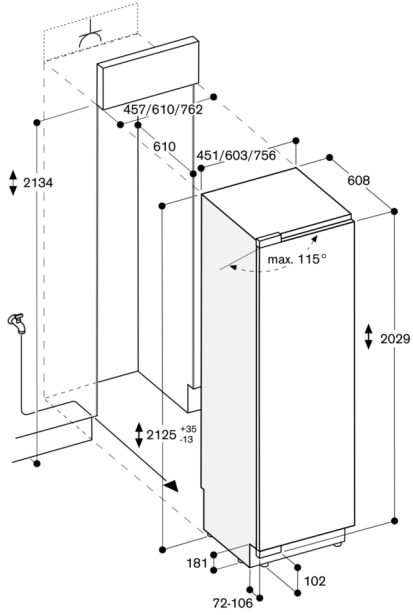

The maximum door panel dimensions are based on a clearance of 3 mm.

Door opening angle

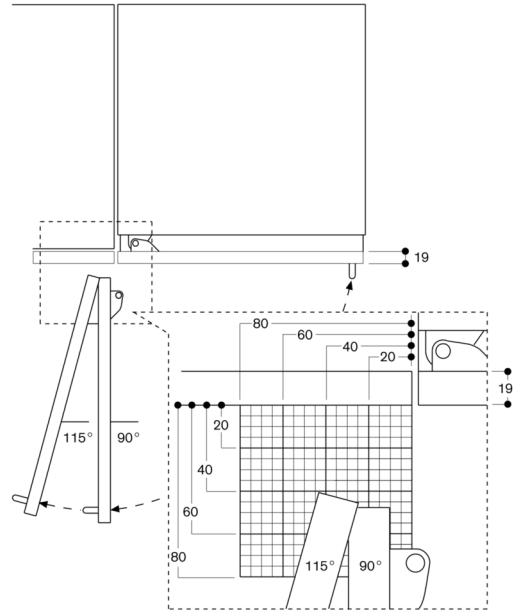

The hinge travel and resulting clearances from adjacent furniture units and handles can be found from the drawing while allowing for the thickness of the front panel. In the drawing, a furniture unit front panel thickness of 19 mm was assumed.

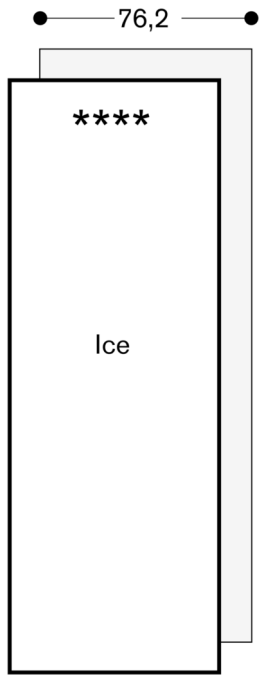

Wall clearance RB 472/RC/RF/RW

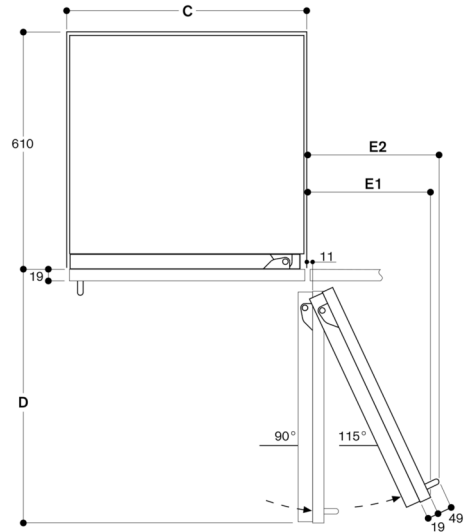

Recess width	D	E1	E2
C			
457 mm	525 mm	235 mm	265 mm
610 mm	677 mm	299 mm	330 mm
762 mm	830 mm	363 mm	395 mm

In the drawing, a unit front thickness of 19 mm and a Gaggenau unit handle of 49 mm were taken as a basis.

Base detail

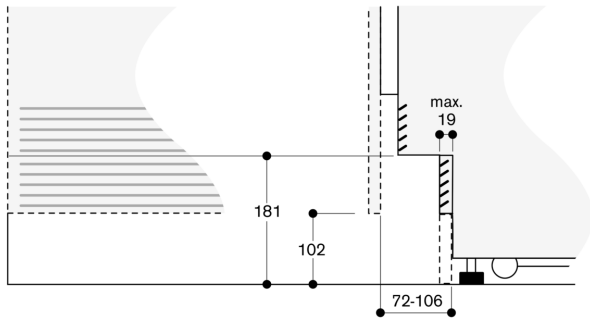

Based on the standard height of the appliance, the height of the plinth is 102 mm. Maximum thickness of the plinth is 19 mm.