



VG264114F

VD201014:
Stainless steel cover series 200

SH260000:
Hinge holder for VG264

VV200014:
Connecting strip series 200 ss

Vario gas cooktop 200 series
60 cm, Liquidgas G30,31 28-30/37 mbar
VG264114F

- Can be combined with the cooktops of the Vario 200 series to a harmonic unity
- Generous control panel for comfortable and secure operation
- Solid smooth-surface cast pan supports for easy and safe positioning of cookware
- Up to 9.4 KW on 4 burners
- 2 high output burners (560 – 2800 W), suitable for pots up to max. ø 22 cm.
- Can be combined with the cooktops of the Vario 200 series to a harmonic unity

Generous control panel for comfortable and secure operation
Solid smooth-surface cast pan supports for easy and safe positioning of cookware
Up to 9.4 KW on 4 burners

Cooking zones

2 high output burners (560 – 2800 W), suitable for pots up to max. ø 22 cm.
2 standard burners (380 – 1900 W), suitable for pots up to max. ø 22 cm.

Handling

Control knobs with cooking zone and output level markings.
One-handed operation.
Electric ignition.

Features

Two-part cast iron pan support with continuous pot surface.
Enamelled burner cover.

Safety

Thermoelectric safety pilot.

Planning notes

Special nozzles can be ordered as spare parts.
Air intake from above.
No intermediate shelf required.
Appliance can be snapped into the worktop from above.
Securing rail on the rear and the front.
A minimum lateral clearance of at least 150 mm from adjacent heat-sensitive furniture or contact surfaces must be observed or thermal insulation fitted.
With a total connected load of more than 11 kW local regulations concerning room ventilation, room size and combination of extraction or recirculation hoods must be observed.
Special nozzles (order 2 of each):
Part No. 433603 Natural gas 20 mbar Part No. 419831 Liquid gas 30 mbar Part No. 419830 Liquid gas 50 mbar

Connection

Total connected load gas 9.4 KW.
Total connected load electric 1.0 W.
Connecting cable 1.4 m with plug.

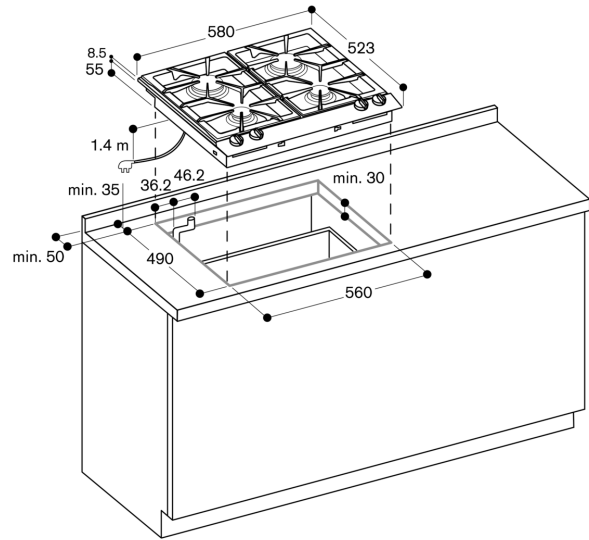
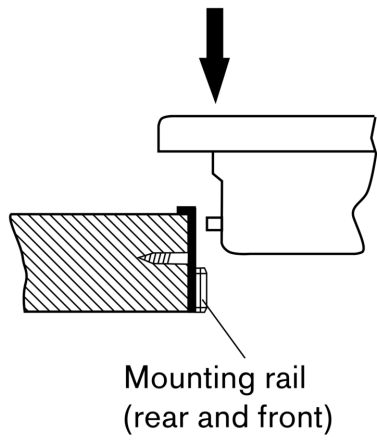

Gas connection

