



RF463505

1 x connection set

RA450012:
Water filter Vario 400

RA460020:
Frontpanel connection long

RA464618:
Vent grille 61cm / 24", left, for RF463

RA422610:
SS door 61cm / 24" for RF463

RA423140:
Side trims, long

RA425110:
Vario SS handle 1131 mm

RA428810:
SS door w/o handle 61cm / 24" for RF463

RA460013:
Heating side kit 230V

Vario freezer 400 series
212.5 x 60.3 cm, Soft close flat hinge
RF463505

- The opening assistance for handle and handleless options reveals a stainless steel interior with glare-free lighting and discreet shelving rails, movable door racks.
- Opening assist for door with two options
- Glare-Free LED Light Spots
- Integrated ice maker
- Stainless steel interior with solid anthracite aluminium elements

Brilliant LED light spots with warm white, glare-free light (3500 K).

Opening assist for door with two options:

1. Push-to-open function for integration into handleless furniture front
2. Pull-to-open function to facilitate opening the door using a handle

The drawers in the RC and RF models are positioned at the same height. With side-by-side installation, the glass shelves can be aligned on the same level

Flat stainless steel inner door, full-length

Proximity sensor for ice and water dispenser

Illuminated dispenser for ice cubes, crushed ice and chilled water

TFT touch display

Handling

TFT touch display operation.

Clear text display.

Touch key operation for ice and water dispenser.

Technical Features

Dynamic cold air distribution.

Automatic defrosting with defrost water evaporation.

Rest mode certified by Star-K.

When rest mode is active, the appliance can only be opened using a handle.

Open-door and malfunction alarm.

Freezing

Total volume 304 l.

No-frost technology with fast freezing at -30 °C.

Temperature adjustable from -14 °C to -24 °C.

Freezing capacity 14 kg/24 h.

Storage time after a malfunction 10 h.

2 fully extendable drawers with transparent front.

3 safety glass shelves, white glass, 2 of which are individually height adjustable.

Ice and water dispenser

Warm white LED lighting.

Proximity sensor for automatic activation of light and touch keys for ice and water dispenser.

Integrated, with fixed inlet water connection.

Particle filter for water inlet, integrated in ventilation grill area.

Can be switched off.

Ice cube production approx. 1.4 kg/24 h.

Ice cubes and crushed ice.

Removable ice storage container with approx.

3.2 kg capacity.

Ice water supply approx. 1.5 litres.

Consumption data

3 stars.

Energy consumption 313 kWh/year.
Noise level 38 dB (re 1 pW).

Planning notes

Flat hinge.

Door opening angle of 115°, fixable at 90°.

For an installation with a door opening angle of 90°, the drawers have a restricted access.

Max. door panel weight 67 kg.

Shut-off valve for water connection must be planned next to the appliance and always be accessible.

If the water pressure exceeds 0.8 MPa (8 bar), connect pressure relief valve between water tap and hose set.

Connection

Total connected load 0.300 KW.

Connecting cable 3.0 m, detachable.

Water inlet.

Supply hose 2.9 m with 3/4" connection.

Water pressure 2 to 8 bar.

Door opening angle

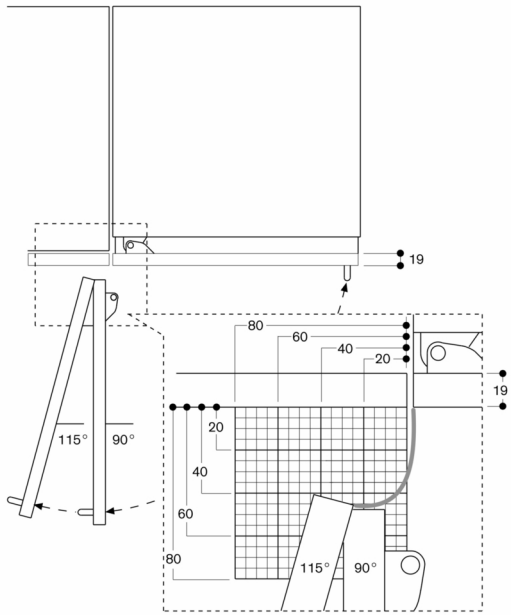

The hinge travel and resulting clearances from adjacent furniture units and handles can be found from the drawing while allowing for the thickness of the front panel. In the drawing, a furniture unit front panel thickness of 19 mm was assumed.

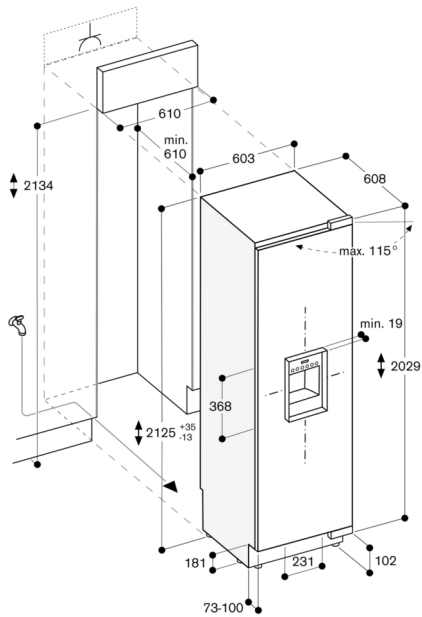
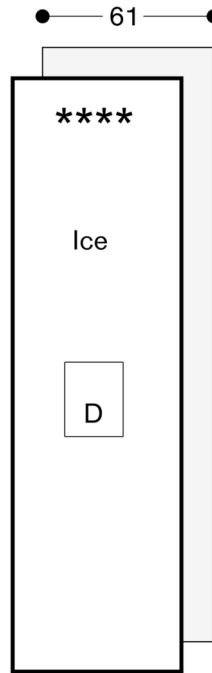

The maximum door panel dimensions are based on a clearance of 3 mm.

Wall clearance RB 472/RC/RF/RW

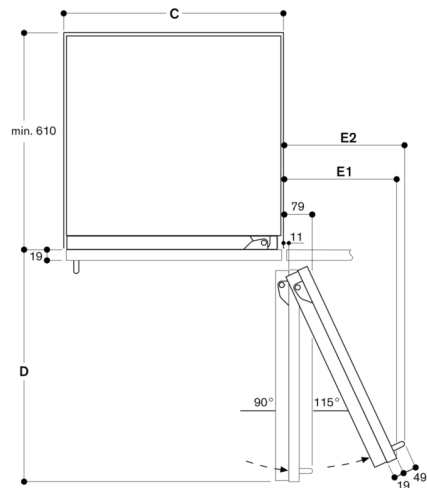

Recess width	D	E1	E2	
C	457 mm	525 mm	235 mm	265 mm
	610 mm	677 mm	299 mm	330 mm
	762 mm	830 mm	364 mm	395 mm
	914 mm	980 mm	428 mm	460 mm

In the drawing, a unit front thickness of 19 mm and a Gaggenau unit handle of 49 mm were taken as a basis.