



**RF463707**  
**Vario freezer 400 series**  
**Niche width 61 cm, Niche height 213.4 cm**



Stainless steel interior with solid anthracite aluminium elements  
 Warm white and glare-free LED light spots  
 Opening assist for door with two options:  
 1. Push-to-open function for integration into handleless furniture front  
 2. Pull-to-open function to facilitate opening the door using a handle  
 The drawers in the RC and RF models are positioned at the same height.  
 With side-by-side installation, the glass shelves and door racks can be aligned on the same level  
 Flat stainless steel inner door, full-length  
 Integrated ice maker with fixed inlet water connection  
 Proximity sensor for ice and water dispenser  
 Illuminated dispenser for ice cubes, crushed ice and chilled water  
 TFT touch display  
 Net volume 318 litres  
 Energy star qualified

**Handling**  
 TFT touch display operation.  
 Clear text display.  
 Touch key operation for ice and water dispenser.

**Technical Features**  
 Dynamic cold air distribution.  
 Automatic defrosting with defrost water evaporation.  
 Cushioned door closing system.  
 Rest mode certified by Star-K.  
 When rest mode is active, the appliance can only be opened using a handle.  
 Open-door and malfunction alarm.  
 Home network integration for digital services (Home Connect) wireless via WiFi.  
 The use of the Home Connect functionality depends on the Home Connect services, which are not available in every country. For further information please check: [home-connect.com](http://home-connect.com).

**Freezing**  
 No-frost technology with fast freezing at -30 °C.  
 Temperature adjustable from -16 °C to -24 °C.  
 4-star freezer compartment.  
 Freezing capacity 8.7 kg/24 h.  
 4 safety glass shelves, white glass, 2 of which are individually height adjustable.  
 2 fully extendable drawers with transparent front.

**Ice and water dispenser**  
 Warm white LED lighting.  
 Proximity sensor for automatic activation of light and touch keys for ice and water dispenser.  
 Integrated, with fixed inlet water connection.  
 Particle filter for water inlet, integrated in ventilation grille area.  
 Can be switched off.  
 Ice cube production approx. 1.1 kg/24 h.  
 Ice cubes and crushed ice.  
 Removable ice storage container with approx. 3.2 kg capacity.  
 Ice water supply approx. 1.3 litres.

**Product Features**  
**UPC code**  
 825225961161  
**Variant color**  
 Not applicable  
**Panel ready**  
**Installation Type**  
 N/A  
**Silence level**  
 42  
**Watts**  
 350  
**Fuse protection**  
 10  
**Volts**  
 110-120  
**Frequency**  
 60  
**Energy consumption**  
 454.0  
**Energy Star® qualified**  
 Yes  
**Approval certificates**  
 CSA  
**Power cord length (in)**  
 118,1"  
**Plug type**  
 120V-3 prong  
**Appliance dimensions (h x w x d) inch**  
 83 3/4 " x 23 3/4 " x 24"  
**Required cutout size (HxWxD) (in)**  
 84" x 24" x 24 3/4"  
**Appliance Width (in)**  
 23 3/4 "  
**Height (in)**  
 83 3/4 "  
**Depth (in)**  
 24"  
**Product packaging dimensions (HxWxD)**  
 84.25 x 27.36 x 29.92  
**Total unit gross capacity - AHAM**  
 11.2  
**Net weight**  
 334.000  
**Gross weight**  
 367.000

**Consumption and connection features**  
**2021-12-21**  
 Page 1

## Consumption data

Energy consumption 454 kWh/year.  
 Noise level 42 dB (re 1 pW).

### Planning notes

Flat hinge.  
 Door opening angle of 115°, fixable at 90°.  
 Max. door panel weight 67 kg.  
 Shut-off valve for water connection must be planned next to the appliance and always be accessible.  
 If the water pressure exceeds 0.8 MPa (8 bar), connect pressure relief valve between water tap and hose set.

### Connection

Total connected load 0.350 KW.  
 Total Amps: 10 A.  
 Connecting cable 118" (3.0 m), detachable.  
 Water inlet.  
 Supply hose length 1.2 m mit 3/4" connection.  
 Water pressure 2 to 8 bar.

### Color Variants

**RF463707**  
**Niche width 61 cm, Niche height 213.4 cm**

### Included accessories

1 x connection set.

### Installation Accessories

**RA422611**  
**Stainless steel door panel with handle**  
**RA423140**  
**RA425110**  
**Handle bar, stainless steel, long**  
**RA428811**  
**RA460012**  
**RA460020**  
**Connecting element for vertically split appliance fronts (for a flush front)**  
**RA464618**  
**Ventilation grille stainless steel**

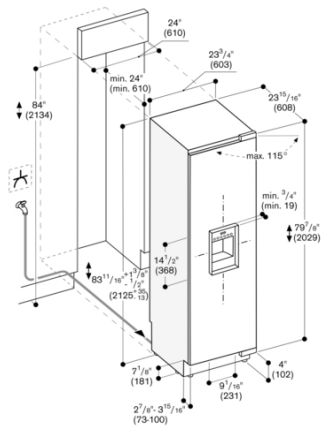
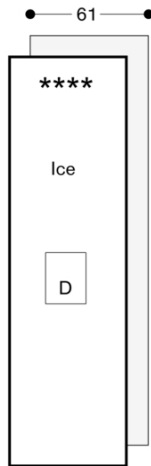

The maximum door front dimensions are based on a clearance of 3/8mm.