



AI442160
Island hood 400 series
stainless steel
Width 160 cm
Air extraction/recirculation
Motorless
Delivery without chimney



Professional technology hood combined with classic Gaggenau design
Highly efficient extraction of cooking vapours due to large vapour collection area
Motorless, can be combined with Gaggenau BLDC remote fan units
Angled baffle filter with high grease absorption
Function for automatic, sensor-controlled power adjustment depending on the build-up of cooking vapours
Dimmable, neutral white surface LED light for ideal illumination of the whole cooktop
Air extraction or recirculation system
Recirculation module with activated charcoal filter: Silent and highly efficient air recirculation solution with odour reduction comparable to air extraction and long replacement intervals

Output

Power levels depend on the remote fan unit.

Features

2 control panels
Three electronically controlled power levels and an intensive mode.
Automatic function with sensor-controlled run-on function.
Grease filter saturation indicator.
Baffle filter, dishwasher-safe.
Neutral white surface LED light (3500 K), continuously dimmable.
Lamp output 4 x LED light bars 10W.
Illuminance: 1390 lx

Product rating

Consumption data is referred to a configuration with the remote fan unit AR 400 143.
Energy efficiency class A at a range of energy efficiency classes from A+++ to D.
Energy consumption 53.5 kWh/year.
Ventilation efficiency class A.
Illumination efficiency class B.
Grease filter efficiency class B.
Sound level min. 45 dB / max. 62 dB normal mode.

Planning notes

The two-part chimney including the mounting kit must be ordered as an installation accessory.
Connection to the respective appliances via network cable.
Clearance above gas appliances min. 70 cm.
Clearance above electric appliances min. 60 cm.
Air recirculation module with 2 activated charcoal filters is installed in the inner chimney. Special air recirculation chimneys are available for this.
When installing a ventilation hood with air extraction mode and a chimney-vented fireplace, the power supply line of the ventilation appliance needs a suitable safety switch.

Connection

Total connected load 50 W.
Connecting cable 1.8 m, pluggable.

Characteristics

Product name/family
Color chimney
Typology
Island/Ceiling
Approval certificates
Australia Standards, CE, Eurasian, G-Mark, Ukraine, VDE
Length of electrical supply cord
175
Required niche size for installation (HxWxD)
Height of the chimney
Height of product, without chimney
102
Minimum distance above an electric hob
600
Minimum distance above a gas hob
700
Net weight
53.5
Type of control
Electronic
Number of speed settings
Maximum output air extraction
640
Boost position output recirculating
Maximum output recirculating air
550
Boost position air extraction
Number of lights (Stck)
4
Noise level
62
Diameter of air outlet
150
Grease filter material
Washable stainless steel
EAN code
4242006239060
Connection rating
50
Fuse protection
10
Voltage
220-230
Frequency
50; 60
Plug type
Gardy plug w/ earthing
Installation type
Island

Consumption and connection features

created on 2022-08-10
Page 1

Color Variants

AI442160
stainless steel
Width 160 cm

Optional accessories

AA400510
Window contact switch
AA442110
2 activated charcoal filter with high efficient odour reduction due to increased surface. For air recirculation module AA 442 810
AA442810
Air recirculation module inclusive 2 activated charcoal filters with high efficient odour reduction due to increased surface
AD442396
Ceiling collar for air ducts

Required installation accessories

AD442016
Stainless steel air extraction chimney, including installation tower
AD442026
Stainless steel air extraction chimney, including installation tower
AD442126
Stainless steel air recirculation chimney, including installation tower

AI442160
 Island hood 400 series
 stainless steel
 Width 160 cm
 Air extraction/recirculation
 Motorless
 Delivery without chimney
 created on 2022-08-10
 Page 2

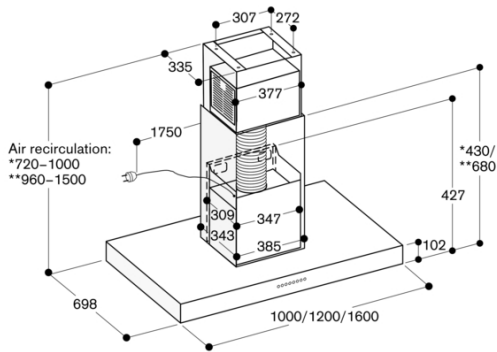

- * With air recirculation chimney AD 442 116, suitable for ceiling heights from 2.35 m to 2.60 m.
- ** With air recirculation chimney AD 442 126, suitable for ceiling heights from 2.60 m to 3.10 m; Specifications refer to the distance of 1.60 m from the floor to the lower edge of the hood.

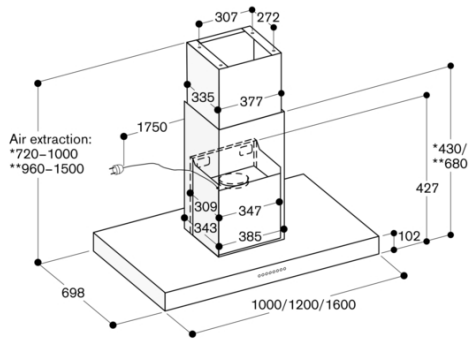

- * With air extraction chimney 442 016, suitable for ceiling heights from 2.35 m to 2.60 m.
- ** With air extraction chimney AD 442 026, suitable for ceiling heights from 2.60 m to 3.10 m; Specifications refer to the distance of 1.60 m from the floor to the lower edge of the hood.