



CE261114

Glass ceramic cooktop 200 series 60 cm

CE261114

- Sturdy stainless steel frame
- Sensor control with direct selection of output level
- 1 Super-Quick cooking zone ø 17 cm (1800 W), switches to 17 x 26,5 cm (2600 W) roasting zone.
- 1 Super-Quick cooking zone ø 14.5 cm (1200 W), converts to ø 21 cm (2100 W, with booster function 2600 W) cooking zone.
- 1 Super-Quick cooking zone ø 18 cm (2000 W).
- Sturdy stainless steel frame
- Sensor control with direct selection of output level

Cooking zones

1 Super-Quick cooking zone ø 17 cm (1800 W), switches to 17 x 26,5 cm (2600 W) roasting zone.

1 Super-Quick cooking zone ø 14.5 cm (1200 W), converts to ø 21 cm (2100 W, with booster function 2600 W) cooking zone.

1 Super-Quick cooking zone ø 18 cm (2000 W).

1 Super-Quick cooking zone ø 14.5 cm (1200 W).

Handling

Sensor control with direct selection of output level.

Cooking zone marking.

Electronic power control in Variable 17-stage power settings for each zone.

Features

Booster function.

Cooking timer for up to 99 minutes.

Short-term timer.

Options menu.

Safety

Main switch.

Operation indicator.

2 stage Hh residual heat indicator for each zone

Child lock.

Safety shut-off.

Planning notes

Immersion depth 49 mm, depth at plug socket 50 mm.

Under the plug socket, a 10 mm clearance must be observed from side panels or from intermediate shelf.

The cooktop must be freely accessible from underneath to be able to detach the cooktop's base in a downward direction.

Installation possible in a 60 cm wide lower cabinet.

Appliance must be fixed from underneath.

Cooktop clamping range: 20 - 50 mm.

Appliance weight: approx. 9.

Connection

Total connected load 8.3 KW.

Plan a connection cable.

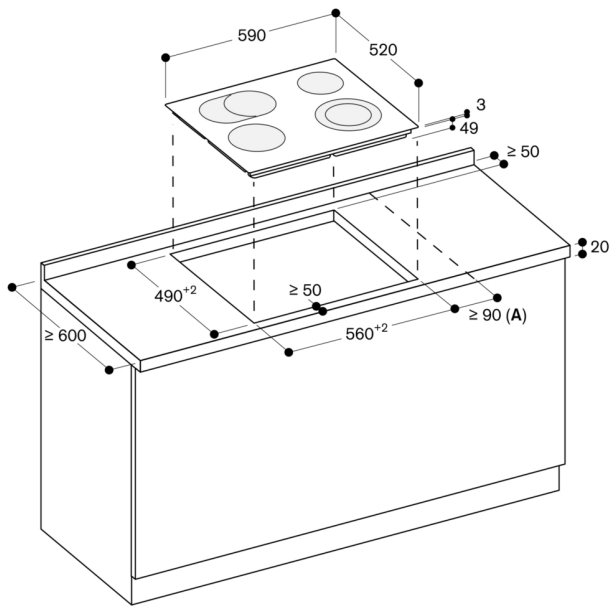

A: Minimum distance from the hob cut-out to the wall.

measurements in mm