



CI283101
Flex induction cooktop 200 series
Frameless
Width 80 cm

Frameless for flush installation
Flex function for combining the rectangular cooking areas
Free positioning of cookware inside combined cooking areas
Frying sensor function for temperature control in pans
Twist-Pad control with removable magnetic knob
Easy control of all functions with two color displays

Cooking zones

2 flex induction cooking areas 19x21 cm (2200 W, with booster 3700 W), linked together 38x21 cm (3300 W, with booster 3700 W).
1 induction cooking zone ø 24 cm (2200 W, with booster 3700 W).
1 induction cooking zone ø 18 cm (1800 W, with booster 3100 W).
1 induction cooking zone ø 15 cm (1400 W, with booster 2200 W).

Handling

Twist-Pad control with removable magnetic knob.
User friendly control with two color display (white / orange).
Cooking zone, and cooking area marking.
Electronic power control in 17 output levels.

Features

Flex function for rectangular cooking areas.
Frying sensor function.
Booster function for pots.
Booster function for pans.
Keep warm function.
Stopwatch.
Cooking timer for up to 99 minutes.
Short-term timer.
Options menu.
Power management.
Cooktop-based ventilation control (with suitable hood).
Integrated WiFi module for digital services (Home Connect).
The availability of the Home Connect functionality depends on the availability of the Home Connect Services in your country. Home Connect Services are not available in every country – for further information please check: www.home-connect.com

Safety

Main switch.
Operation indicator.
Pot detection.
2 stage Hh residual heat indicator for each zone
Child lock.
Safety shut-off.

Planning notes

Operates with magnetic (induction) iron pots and pans only. For an optimal heat distribution, the use of sandwich bottom cookware is recommended.
The wok pan WP 400 001 cannot be used with this appliance.
Immersion depth 56 mm.
Intermediate shelf is recommended.
Appliance must be fixed from underneath.
Cooktop clamping range: 20 - 40 mm.
Appliance weight: approx. 19 kg.

Connection

Characteristics

Product name/family
Cooking zone ceramic

Construction type
Built-in

Energy input
Electric

Total number of positions that can be used at the same time
5

Type of control setting devices

Required niche size for installation (HxWxD)
56 x 780-798 x 490-518

Width of the product (mm)
793

Dimensions of the product (mm)
56 x 793 x 513

Dimensions of the packed product (HxWxD) (mm)
126 x 953 x 603

Net weight (kg)
18.523

Gross weight (kg)
20.0

Residual heat indicator
Separate

Location of control panel
Hob front

Type of external control possibility

Basic surface material
Ceramic

Color of surface
Black

Color of frame

Approval certificates
AENOR, CE

Length of electrical supply cord (cm)
150

EAN code
4242006267049

Consumption and connection features

Electrical connection rating (W)
7400

Gas connection rating (W)

Current (A)

Voltage (V)
220-240

Frequency (Hz)
60; 50

created on 2020-02-19

Page 1

Total connected load 7.4 kW.
Connecting cable 1.5 m without plug.
Power consumption standby/display off 0.5 W.
Power consumption standby/network 2 W.
Please check the user manual for how to switch off the WiFi module.

Color Variants

CI283101
Frameless
Width 80 cm

Optional accessories

GP900001
Stainless steel frying sensor pan

GP900002
Stainless steel frying sensor pan

GP900003
Stainless steel frying sensor pan

View from above

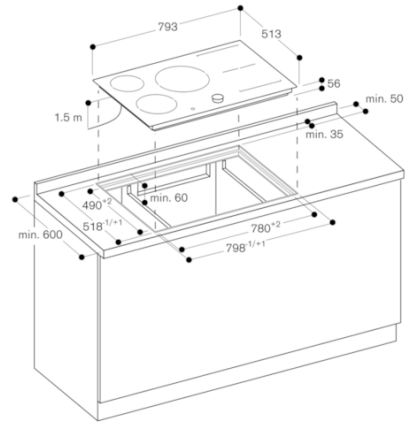
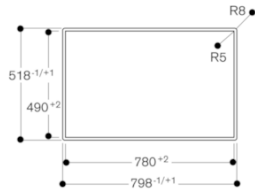

Longitudinal section

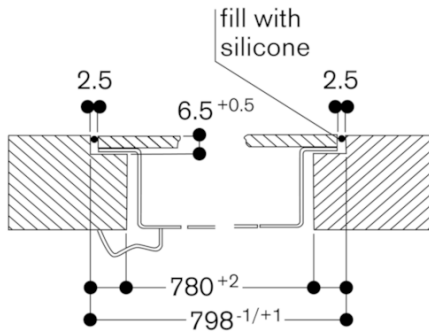

Cross section

