



Color Variants

RB472304
with fresh cooling close to 0 °C
fully integrated

Included accessories

1 x egg box with lid.
1 x ice cube scoop.

Optional accessories

RA430100
RA450000
Mechanical particle filter.

Installation Accessories

RA421712
Stainless steel door panels with handles
RA423340
RA425110
Handle bar, stainless steel, long
RA425710
Handle bar, stainless steel, short
RA428712
RA460000
Accessory for side-by-side installation
RA460013
RA460030
Connecting element for vertically split fronts (for fridge-freezer combination with one door)
RA464710
Ventilation grille stainless steel

RB472304

Vario fridge-freezer combination 400 series

with fresh cooling close to 0 °C
fully integrated

Niche width 76.2 cm, Niche height 213.4 cm

Cooling-freezing-combination Cooling section with one door and one fully extendable freezer drawer

Stainless steel interior with solid anthracite aluminium elements
Warm white and glare-free LED light spots

Opening assist for door with two options:

1. Push-to-open function for integration into handleless furniture front
 2. Pull-to-open function to facilitate opening the door using a handle
- Flat stainless steel inner door, full-length

Smooth design rail system providing flexible positioning for shelves and door racks
Solid anthracite aluminium door racks
One fresh cooling drawer close to 0 °C with manually adjustable temperature and one fresh cooling drawer with manually adjustable humidity
Integrated ice maker with fixed inlet water connection
Fully extendable freezer drawer with practical divider in anthracite
TFT touch display
Net volume 418 litres

Handling

TFT touch display operation.
Clear text display.

Features

Dynamic cold air distribution.
Automatic defrosting with defrost water evaporation.
Cushioned door closing system.
Activated charcoal air filter.
Rest mode certified by Star-K.
When rest mode is active, the appliance can only be opened using a handle.
Open-door and malfunction alarm.
Integrated WiFi module for digital services (Home Connect).
The availability of the Home Connect functionality depends on the availability of the Home Connect Services in your country. Home Connect Services are not available in every country – for further information please check: www.home-connect.com

Cooling

No-frost technology with fast cooling.
Temperature adjustable from +2 °C to +8 °C.

3 safety glass shelves, white glass, 2 of which are individually adjustable in height.

4 brilliant LED light spots with warm white, glare-free light within cooling area and drawers.

Smooth design door rail system with fully flexible positioning of door racks.
3 height adjustable door racks, 1 of which is extra deep.
Net volume 281 litres.

Fresh cooling close to 0 °C

1 fully extendable fresh cooling drawer close to 0 °C with transparent front, illuminated.

Cushioned closing system.
Temperature can be adjusted manually.
Ideal for meat, fish and poultry.
Net volume 27 litres.

Fresh cooling

1 fully extendable fresh cooling drawer with transparent front, illuminated.
Cushioned closing system.

Characteristics

Construction type

Built-in

Door panel options

Not possible

Height

2125

Width of the product

756

Depth of the product

608

Required niche size for installation (HxWxD)

2134.0 x 762.0 x 610

Net weight

193.033

Connection rating

300

Fuse protection

10

Door hinge

Right reversible

Voltage

220-240

Frequency

50-60

Approval certificates

CE, VDE

Length of electrical supply cord

300

Energy consumption

Total annual energy consumption

Refrigerator Net capacity

Freezer Net capacity

Freezing capacity

Storage Period in Event of Power Failure (h)

17

Number of compressors

2

Number of independent cooling systems

2

Interior ventilator

Yes

Reversible Door Hinge

Yes

Number of Adjustable Shelves in fridge compartment (Stck)

2

Shelves for Bottles

No

Capacity of Water Tank

4242006262099

Brand

Gaggenau

Product name / Commercial code

RB472304

Energy efficiency rating

Energy consumption annual - NEW (2010/30/EC)

301.00

Refrigerator Net capacity - NEW (2010/30/EC)

308

Freezer Net capacity - NEW (2010/30/EC)

110

Frost free system

Freezing capacity) - NEW (2010/30/EC)

14

Climate class

SN-T

Noise level

42

Installation type

N/A

Consumption and connection features

created on 2021-12-03

Page 1

Humidity can be adjusted manually.
Ideal for fruit and vegetables.

Freezing

No-frost technology with fast freezing at -30 °C.

Temperature adjustable from -14 °C to -24 °C.

4-star freezer compartment.

Freezing capacity 14 kg/24 h.
Storage time after a malfunction 17 h.
2 fully extendable drawers, one of them inside. Outer drawer with synchronously running pull-out rails.

Interior lighting with 2 LED light spots, warm white light.
Net volume 110 litres.

Ice maker

Integrated in the freezer compartment, with fixed inlet water connection.

Particle filter for water inlet, integrated in ventilation grille area.

Can be switched off.

Ice cube production approx. 1.7 kg/24 h.

Removable ice storage container with approx. 3 kg capacity.

Product rating

Energy efficiency class A++ at a range of energy efficiency classes from A++ + to D.

Energy consumption 301 kWh/year.
Noise level 42 dB (re 1 pW).

Planning notes

Flat hinge.

Door hinge right, reversible.

Door opening angle of 115°, fixable at 90°.

Max. door panel weight:

Door 41 kg.

Drawer 10 kg.

Shut-off valve for water connection must be planned next to the appliance and always be accessible.

If the water pressure exceeds 0.8 MPa (8 bar), connect pressure relief valve between water tap and hose set.

Connection

Total connected load 0.300 KW.

Connecting cable 3.0 m, pluggable.

Water inlet.

Supply hose 2.0 m with 3/4 " connection.

Water pressure 2 to 8 bar.

RB472304

Vario fridge-freezer combination 400 series

with fresh cooling close to 0 °C

fully integrated

Niche width 76.2 cm, Niche height 213.4 cm

Cooling-freezing-combination Cooling section with one door and one fully extendable freezer drawer

created on 2021-12-03

Page 2

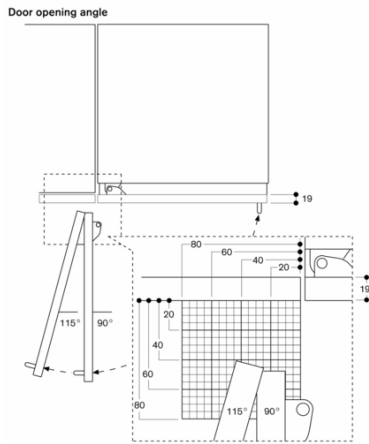

The hinge travel and resulting clearances from adjacent furniture units and handles can be found from the drawing while allowing for the thickness of the front panel. In the drawing, a furniture unit front panel thickness of 19 mm was assumed.

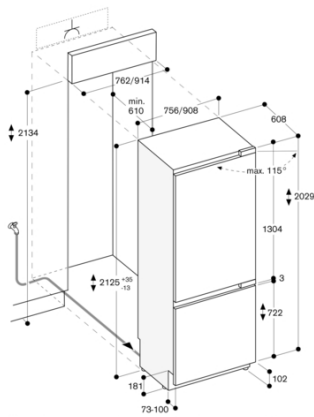

The maximum door panel dimensions are based on a clearance of 3 mm.

Base detail

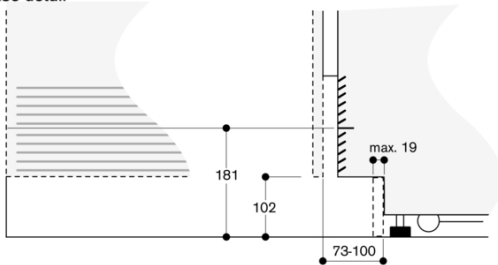

Based on the standard appliance height, the height of the plinth is 102 mm. Maximum plinth thickness 19 mm.

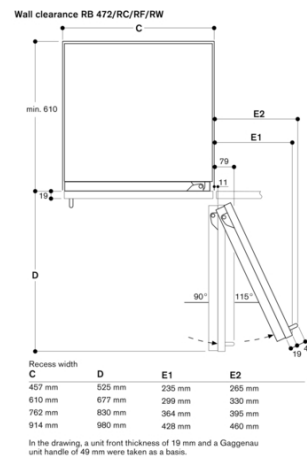

Recess width	C	D	E1	E2
457 mm	525 mm	235 mm	265 mm	
610 mm	677 mm	299 mm	330 mm	
762 mm	830 mm	364 mm	395 mm	
914 mm	980 mm	428 mm	460 mm	

In the drawing, a unit front thickness of 19 mm and a Gaggenau unit handle of 49 mm were taken as a basis.

