



RVF477190



Included accessories

1 x ice cube scoop
1 x Ice storage container large

Optional accessories

RA450012:
Water filter Vario 400

installation accessories

RA425110:
Vario SS handle 1131 mm

RA460020:
Frontpanel connection long

RVA421722:
SS door with handle 76.2 cm (30")

RVA423141:
Side trims, 3 mm

RVA428722:
SS door w/o handle 76.2 cm (30")

RVA460000:
Installationskit side-by-side

RVA460020:
Backward compatibility kit SbS

RVA466700:
Door direction change kit 76.2 cm (30")

freezer Vario cooling Expressive series
213.4 x 76.2 cm
RVF477190

Highlights

Dark brushed stainless steel interior, refined with solid anthracite aluminium elements
Warm white and glare-free LED light concept for optimal food presentation in all compartments
Opening assist for door with two options:
1. Push-to-open function for integration into handleless furniture front
2. Pull-to-open function to facilitate opening the door using a handle
The drawers in the RVC and RVF models are positioned at the same height. With side-by-side installation, the glass shelves and door racks can be aligned on the same level.
Flexible positioning of shelves and door racks through hidden rail system
Flat dark brushed stainless steel inner door
Total volume 516 litres

Handling

Opening assist for door.
Cushioned door closing system.
User guidance through light and display response to drawer interaction.
Automatic brightness adjustment based on ambient illumination.
Hidden touch display.

Features

Dynamic cold air distribution.
Automatic defrosting with defrost water evaporation.
Rest mode certified by Star-K.
When rest mode is active, the appliance can only be opened using a handle.
Open-door and malfunction alarm.

Selected digital services (Gaggenau Home Connect)

Remote control and monitoring.
Software updates.

Freezing

No-frost technology with fast freezing at -30 °C.
4-star freezer compartment.
Temperature adjustable from -16 °C to -24 °C.
Freezer burn protection.
Oxidation protection.
Freezing capacity 25 kg /24 h.
Storage time after a malfunction 19 h.
Warm-white, glare-free LED lighting (3000 K) within freezer compartment.
3 aluminium-framed safety glass shelves, individually adjustable in height.
Flexible positioning of door racks through hidden rail system.
4 height-adjustable door racks.
3 fully extendable drawers, with cushioned closing system.

Ice maker

Hidden in one drawer for optimised usable space.
With fixed water connection (inlet).
Can be switched off.
Ice cube production: approx. 2.4 kg /24 h.

Removable ice storage container with approx. 3 kg capacity.
Integrated, easy accessible ice cube scoop.
Particle filter for water inlet, integrated in ventilation grille area.
Saturation indicator shown in touch display.

Product rating

Energy efficiency class D at a range of energy efficiency classes from A to G.
Energy consumption 277 kWh/year.
Noise level 38 dB (A) re 1 pW.

Planning notes

Flat hinge.
Door hinge left, reversible.
Door opening angle of 115°, fixable at 90°.
Max. door panel weight 39 kg.
Shut-off valve for water connection must be planned next to the appliance and always be accessible.
If the water pressure exceeds 0.8 MPa (8 bar), connect pressure relief valve between water tap and hose set.

Connection

Total connected load 0.300 KW.
Connecting cable 3.0 m, pluggable.
Water inlet.
Supply hose 1.8 m with 3/4" connection.
Water pressure 2 bar to 8 bar.

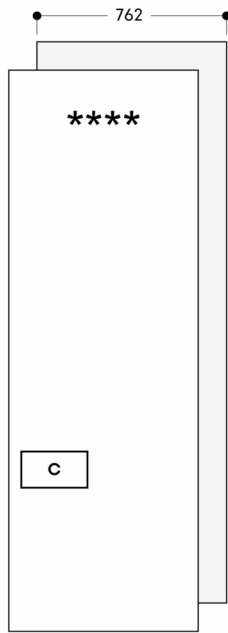

C: Ice maker

Measurements in mm

Wall clearance RVB / RVC / RVF / RVW

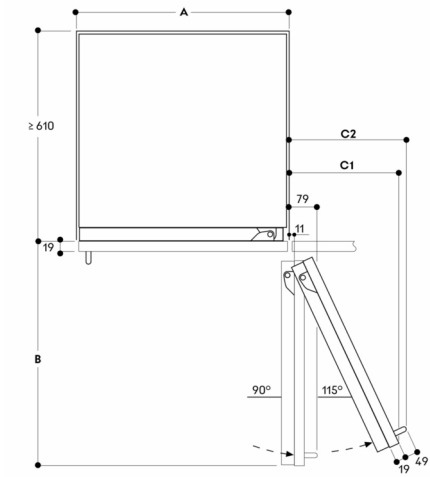

Niche width

A	B	C1	C2
457	525	235	265
610	677	299	330
762	830	364	395
900	970	420	442

The drawing is based on a door panel thickness of 19 mm as well as the height of a Gaggenau handle of 49 mm

Measurements in mm