



RY492301
Vario fridge-freezer combination 400 series
with fresh cooling
fully integrated
Niche width 91.4 cm, Niche height 213.4 cm
With two doors

Stainless steel interior
Generous lighting concept
Solid aluminium door racks
Net volume 526 litres
Integrated ice maker with fixed inlet water connection
One motorised glass shelf, adjustable when fully loaded
One asymmetricly split glass shelf
Fully extendable freezer drawer with practical divider
Energy efficiency class A+

Handling
 Electronic temperature control with digital display.

Features
 Dynamic cold air distribution.
 Automatic defrosting with defrost water evaporation.
 Antimicrobial activated charcoal air filter.
 Energy-saving vacation mode.
 Open-door and malfunction alarm.

Cooling
 Net volume 355 litres.
 No-frost technology with fast cooling. Temperature adjustable from +2 °C to +8 °C.
 2 safety glass shelves, 1 of which is motorised.
 1 asymmetricly split safety glass shelf, manually adjustable.
 2 fully extendable drawers with transparent front.
 Bright interior lighting with light pillars.
 4 height adjustable door racks, 2 of which are extra deep.
 2 door racks with transparent front flap.

Fresh cooling
 Net volume 25 litres.
 No-frost technology.
 1 full width fully extendable fresh cooling drawer with transparent front, manually controllable.

Freezing
 Net volume 146 litres.
 No-frost technology with fast freezing. Temperature adjustable from -14 °C to -25 °C.
 4-star freezer compartment.
 Freezing capacity 16 kg/24 h.
 Storage time after a malfunction 17 h.
 2 fully extendable drawers.
 Interior lighting with 2 spots.

Ice maker
 Integrated in the freezer compartment, with fixed inlet water connection.
 Can be switched off.
 Ice cube production approx. 1.7 kg/24 h.
 Removable ice storage container with approx. 3 kg capacity.

Product rating
 Energy consumption 423 kWh/year.
 Noise level 42 dB (re 1 pW).

Planning notes
 Flat hinge.
 Door opening angle of 115°, fixable at 90°.
 Max. door panel weight:
 Each door 57 kg.
 Drawer 10 kg.

Characteristics
Construction type
 Built-in
Door panel options
 Not possible
Height (mm)
 2125
Width of the product (mm)
 908
Depth of the product
 608
Required niche size for installation (HxWxD)
 2134.0 x 914.0 x 610
Net weight (kg)
 220,526
Connection rating (W)
 574
Current (A)
 10
Door hinge
 Left & Right
Voltage (V)
 220-240
Frequency (Hz)
 50
Approval certificates
 CE, KEMA, VDE
Length of electrical supply cord (cm)
 300
Energy efficiency class
Energy consumption (kWh)
Total annual energy consumption (kWh)
Refrigerator Net capacity (l)
Freezer Net capacity (l)
Freezing capacity (kg)
Storage Period in Event of Power Failure (h)
 17
Number of compressors
 2
Number of independent cooling systems
 2
Interior ventilator
 Yes
Reversible Door Hinge
 No
Number of Adjustable Shelves in fridge compartment (Stck)
 2
Shelves for Bottles
 No
Capacity of Water Tank [l]
EAN code
 4242006217617

Consumption and connection features
Brand
 Gaggenau
Product name / Commercial code
 RY492301
Energy efficiency class (2010/30/EC)
 A+
Energy consumption annual (kWh/annum) - NEW (2010/30/EC)
 423.00
Refrigerator Net capacity (l) - NEW (2010/30/EC)
 380
Freezer Net capacity (l) - NEW (2010/30/EC)
 146
Frost free system
 Fridge and freezer
Temperature rise time (h)
 17
Freezing capacity (kg/24h) - NEW (2010/30/EC)
 16
Climate class
 SN-T
Noise level (dB(A) re 1 pW)
 42
Installation typology
 N/A

created on 2019-04-19
 Page 1

Shut-off valve for water connection must be planned next to the appliance and always be accessible.
 If the water pressure exceeds 0.8 MPa (8 bar), connect pressure relief valve between water tap and hose set.

Connection
 Total connected load 0.574 kW.
 Connecting cable 3.0 m, pluggable.
 Water inlet.
 Supply hose 3.0 m with 3/4 " connection.
 Water pressure 2.4 to 8.3 bar.

Color Variants

RY492301
with fresh cooling
fully integrated

Included accessories

1 x egg box with lid.
 1 x ice cube scoop.

Required installation accessories

RA460000
Accessory for side-by-side installation
RA460011
Additional side heating element

Installation Accessories

RA421912
Stainless steel door panels with handles
RA425110
Handle bar, stainless steel, long
RA425910
Handle bar, stainless steel, short
RA460030
Connecting element for vertically split fronts (for fridge-freezer combination with one door)

RY492301
Vario fridge-freezer combination 400 series
with fresh cooling
fully integrated
Niche width 91.4 cm, Niche height 213.4 cm
cm
With two doors
 created on 2019-04-19
 Page 2

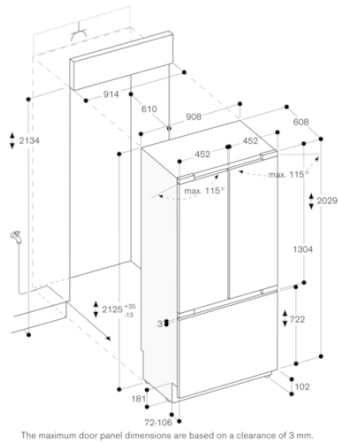

The maximum door panel dimensions are based on a clearance of 3 mm.

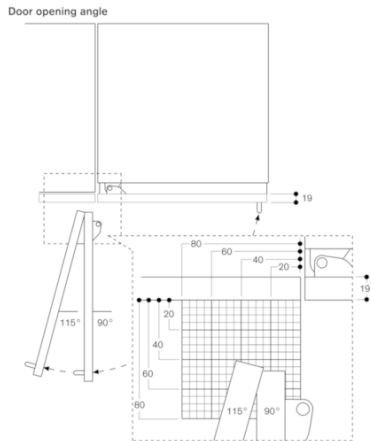

The hinge travel and resulting clearances from adjacent furniture units and handles can be found from the drawing while allowing for the thickness of the front panel. In the drawing, a furniture unit front panel thickness of 19 mm was assumed.

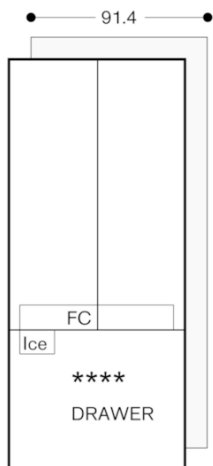

Wall clearance RB 492/RV 492

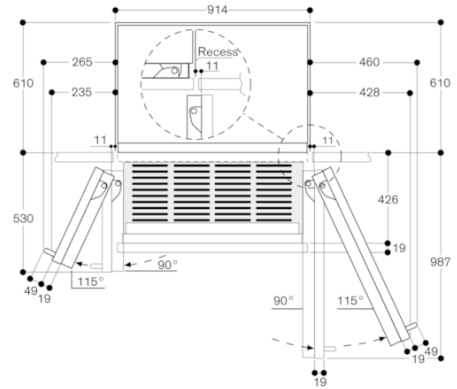

In the drawing, a unit front thickness of 19 mm and a Gaggenau unit handle of 49 mm were taken as a basis.

Base detail

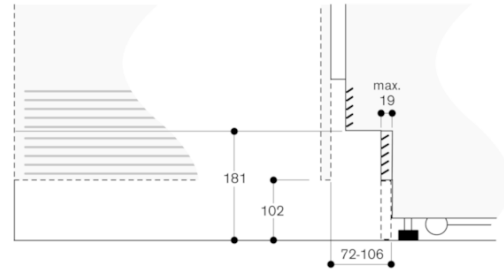

Based on the standard height of the appliance, the height of the plinth is 102 mm. Maximum thickness of the plinth is 19 mm.