



**VG295120F**  
**200 series gas cooktop**  
**Black control panel**  
**Width 90 cm**  
**Liquid gas 28 - 37 mbar**  
**Wok burner with 5.8 KW**

Control panel for comfortable and secure operation  
Mechanical power level regulation for 9 power levels, with exact setting and reproduction of flame size  
Multi-ring burner of solid, heat-resistant brass as used in professional kitchen  
Solid smooth-surface cast pan supports  
Top appliance in the market, 17.8 kW on 5 burners

#### Cooking zones

1 multi-ring wok burner (300 W – 5800 W), suitable for pots up to max. ø 32 cm.  
2 two-ring high output burners (170 W – 4000 W), suitable for pots up to max. ø 28 cm.  
2 two-ring standard burners (170 W – 2000 W), suitable for pots up to max. ø 28 cm.

#### Handling

Control knobs with illuminated ring.  
Integrated control panel.  
One-handed operation.  
Electric ignition.

#### Features

Three-part cast pan support with flat, continuous pot surface.  
Brass burner rings.

#### Safety

Thermoelectric safety pilot.  
Residual heat indication.  
Operation indicator.

#### Planning notes

No intermediate shelf required.  
Appliance can be snapped into the worktop from above.  
Rear panel and wall trims must be heat-resistant and consist of a non-flammable material.  
Installation in a 90 cm wide lower cabinet is required.  
A minimum lateral clearance of at least 300 mm from adjacent heat-sensitive furniture or contact surfaces must be observed or thermal insulation fitted.  
With a total connected load of more than 12 kW local regulations concerning room ventilation, room size and combination of extraction or recirculation hoods must be observed.  
Minimum clearance between gas cooktop(s) with more than 12 kW and ventilation hood 70 cm.  
Appliance weight: approx. 29.

#### Connection

Total connected load gas 17.8 KW.  
Total connected load electric 10.0 W.

#### Characteristics

**Product name/family**  
gas hob w integrated controls  
**Construction type**  
Built-in  
**Energy input**  
Gas  
**Total number of positions that can be used at the same time**  
5  
**Required niche size for installation (HxWxD)**  
106 x 885 x 492  
**Width of the appliance**  
914  
**Dimensions**  
106 x 914 x 510  
**Dimensions of the packed product (HxWxD)**  
290 x 700 x 1010  
**Net weight**  
29.483  
**Gross weight**  
31.8  
**Residual heat indicator**  
Separate  
**Location of control panel**  
Hob front  
**Basic surface material**  
brushed stainless steel  
**Color of surface**  
Stainless steel  
**Color of frame**  
Stainless steel  
**Approval certificates**  
VDE  
**Length of electrical supply cord**  
150  
**EAN code**  
4242006280420  
**Electrical connection rating**  
10  
**Gas connection rating**  
17800  
**Fuse protection**  
10  
**Voltage**  
220-240  
**Frequency**  
60; 50

#### Consumption and connection features

created on 2021-12-07  
Page 1

#### Color Variants

**VG295120F**  
**Black control panel**  
**Width 90 cm**

#### Included accessories

1 x WOK attachment ring.

#### Optional accessories

**WP400001**  
**Wok pan made of multiple-layer material**

VG295120F

200 series gas cooktop

Black control panel

Width 90 cm

Liquid gas 28 - 37 mbar

Wok burner with 5.8 KW

created on 2021-12-07

Page 2

Gas connection

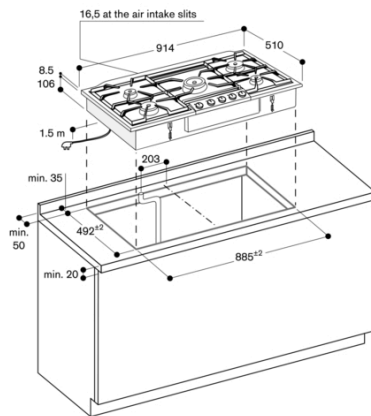
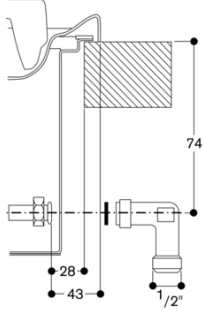

Minimum distance from the appliance cut-out to the side wall 300 mm.