



WT260165

A+++

Optional accessories

WA027500:

Stacking kit with pull-out shelf

WMZ20600:

Wool in basket - accessory

WTZPW20D:

Platform with pull-out, dryer, cubic

Installation Accessories

Tumble dryer with heat pump 200 series
9 kg

WT260165

- Home Connect
 - Very silent drying with only 62 db
 - Heat Pump Technology
 - Self-cleaning condenser for automatic fluff removal
 - Smart Dry automatically selects the right dryer program based on the last washing program
 - Heat pump technology
- Twin rotary compressor for reduced energy consumption
Self-cleaning condenser for automatic fluff removal
Very silent drying with only 58 db
Smart Dry automatically selects the right dryer program based on the last washing program

Handling

Illuminated rotary knob with integrated On-Off switch.
Large touch display with clear text and symbols.
Programme sequence and remaining time display.
Time delay up to 24 h hours.
Multiple signal tones.

Features

Moisture and time controlled programmes.
Heat pump technology.
Self-cleaning heat exchanger.
Refresh function without previous washing cycle.
Anti-crease cycle at programme end.
Top-up function.
Child lock.

Selected digital services (Home Connect)

Smart Energy Management.
Smart Dry (Washing machine automatically selects correct dryer program).
Remote control and monitoring.

Programmes

Cottons.
Eco Cottons.
Easy care.
Mix.
Super 40.
Textile Guard.
Steam Assist.
Shirts/Blouses.
Wool in Basket.
Hygiene.
Towels.
Duvet.
Timed program warm.
App Programmes: Smart Dry, Sports, Dessous, Synthetics, Down, Timed program cold.
Options: Smart Dry, Refresher Options, Half Load, Remote Start, Anti Crease, Easy Iron, Drying Target, Spin Speed, Gentle Dry, Favourite.

Features

varioSoft drum system.
Dry wool without shrinking or matting thanks to the included basket for woollens.
Volume capacity from 1 to 9 kg.

Drum interior lighting.

Product rating

Energy efficiency class A+++ at a range of energy efficiency classes from A+++ to D.

Planning notes

Combines perfectly with washing machine WM 260 165.
Right-hinged, reversible.
Large porthole with 180 ° opening angle.
Height-adjustable feet.
Height for slide-under installation: 84.2 cm.
Stackable above washing machine WM 260 165 in combination with special accessory. With pull-out shelf WZ27500.

Connection

Total connected load 0.6 KW.
Connection cable 1.45 m with plug.

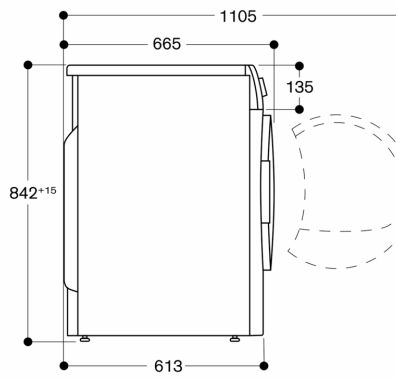

Measurements in mm

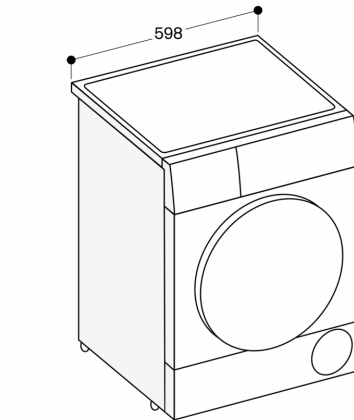

Measurements in mm

Side view of WT 260 above WM 260 with conn

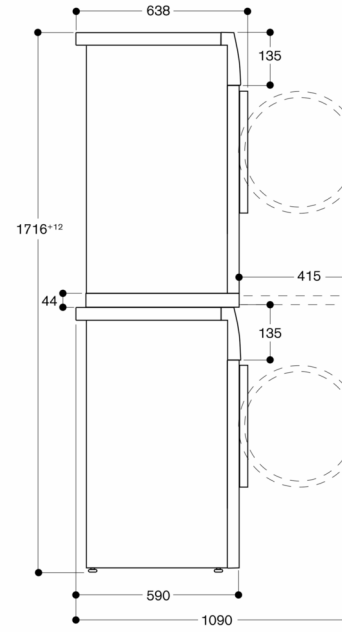

Measurements in mm