



AW230190

AA200110:

Repl. filter for AA200812/816, AA010810

AA200812:

Recirculation module w.active charcoal

AD200322:

Chimney elongation stainless steel

AD200392:

Ceiling Collar Stainless Steel Wall

## wall-mounted cooker hood 200 series

90 cm, Stainless steel

AW230190

Classic Gaggenau design

Highly efficient extraction of cooking vapours

Energy-saving, low-noise fan

Patented filter technology with high grease absorption

Rim extraction filter with flat and easy-to-clean stainless steel underside

Function for automatic, sensor-controlled power adjustment depending on the build-up of cooking vapours

Dimmable, neutral white LED light for ideal illumination of the whole cooktop

Air extraction or air recirculation system

Air recirculation module with activated charcoal filter: quiet and highly efficient air recirculation solution with odour reduction as in air extraction mode and long replacement intervals

### Output

Performance and noise level, output level 3/Intensive: Air output according to EN 61591. Sound power level according to EN 60704-3. Sound pressure level according to EN 60704-2-13. Odour reduction for air recirculation in accordance with EN 61591.

Air extraction: 610 / 810 m<sup>3</sup>/h. 66 / 72 dB (A) re 1 pW. 52 / 58 dB (A) re 20 µPa.

Air recirculation: 450 / 530 m<sup>3</sup>/h. 70 / 74 dB (A) re 1 pW. 56 / 60 dB (A) re 20 µPa.

Odour reduction air recirculation 95%.

### Features

3 electronically controlled power levels and 1 intensive mode.

Automatic function with sensor-controlled run-on function.

Grease filter saturation indicator.

Patented rim extraction filter, dishwasher-safe.

Neutral white LED light (3600 K), continuously dimmable.

Lamp output 3 x LED 6medium power 5W stripe.

Illuminance 731 lx.

Fan technology with highly efficient, brushless DC motor (BLDC).

Airflow-optimised interior for efficient air circulation.

Easy mounting system for simple installation and alignment.

The package includes an one-way flap.

### Consumption data

Energy efficiency class B at a range of energy efficiency classes from A++ to E.

Energy consumption 38.8 kWh/year.

Ventilation efficiency class A.

Illumination efficiency class A.

Grease filter efficiency class B.

Sound level min. 44 dB / max. 66 dB normal mode.

### Planning notes

The package includes the two-part chimney with the dimensions from 582 mm to 864 mm.

Individual planning solutions can be implemented using the special accessory chimney extension AD 200 322 or by shortening the lower edge of the inner chimney.

Clearance above gas appliances min. 65 cm

(more than total load gas 12 kW min. 70 cm).

Clearance above electric appliances min. 55 cm.

The air recirculation module with activated charcoal filter can be installed on the external chimney or inner chimney.

When installing a ventilation hood with air extraction mode and a chimney-vented fireplace, the power supply line of the ventilation appliance needs a suitable safety switch.

### Connection

Total connected load 275 W.

Connecting cable 1.3 m with plug.

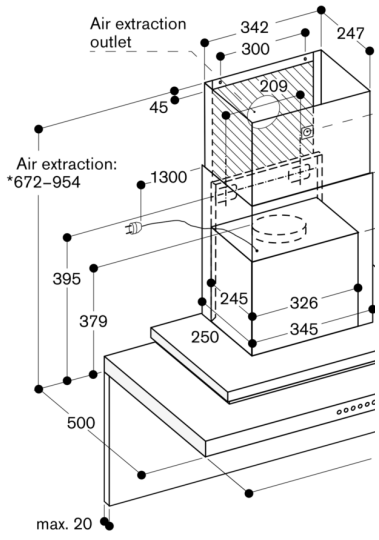

\* Suitable for ceiling heights from 2.27 m to 2.55 m  
 Specifications refer to the distance of 1.60 m from the floor to the lower edge of the hood.

AW 230 with AA 200 812

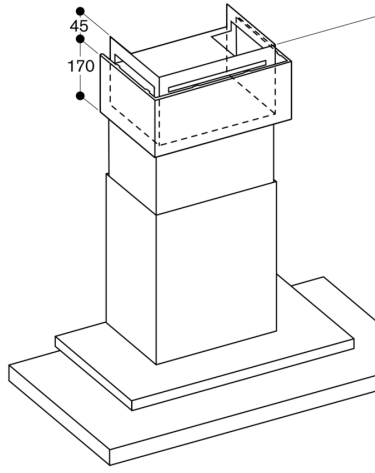

\* Suitable for ceiling heights from 2.45 m to 2.75 m  
 Specifications refer to the distance of 1.60 m from the floor to the lower edge of the hood.

AW 230 with AD 200 322

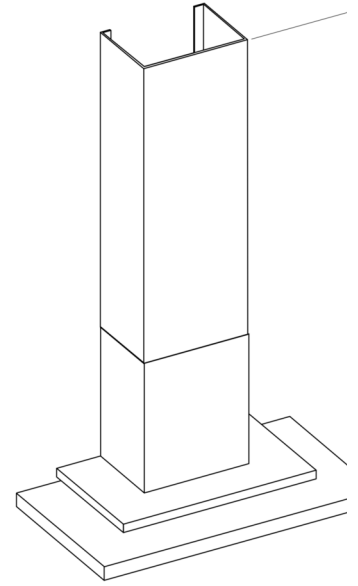

\* Suitable for ceiling heights from 2.64 m to 2.97 m;  
 Specifications refer to the distance of 1.60 m from the floor to the lower edge of the hood.