



CMP250132

### Built-In Fully Automatic Coffee Machine 200 Series

60 x 45 cm, Silver, Removable water tank

**CMP250132**

- 12 different beverage types
- Save up to 8 individualised beverages
- Two cup brewing simultaneously
- Water, bean and milk levels
- Handless door / cushioned door closing system

Continuous flow heater means no waiting time and constant brewing temperature  
Aroma brewing technology for a full aroma  
Single portion cleaning  
TFT touch display  
Panel-free appliance with surface control module  
One-touch operation  
Personalisation function  
7 light settings  
Electronic fill level control for milk, water and coffee to ensure a perfect result

#### Type of beverage

Ristretto / 2 x Ristretto.  
Espresso / 2 x Espresso. Espresso Macchiato / 2 x Espresso Macchiato. Coffee / 2 x Coffee.  
Americano / 2 x Americano. Caffè Latte / 2 x Caffè Latte. Latte Macchiato / 2 x Latte Macchiato. Cappuccino / 2 x Cappuccino. Flat White / 2 x Flat White. Milk froth / 2 x Milk froth.  
Warm milk / 2 x Warm milk. Hot water / 2 x Hot water.

#### Capacity

Door with cushioned door closing system.  
Rotary knob and TFT touch display operation.  
Clear text display.  
Personalisation function, option to save 8 individualised beverages.  
4 beverage size settings, volume can be individually adjusted to match the size of the cup.  
8 coffee strength levels from very mild to extra strong.  
Adjustable grinding level.  
Height-adjustable coffee dispenser 7 cm to 15 cm.  
Easy access to water tank, milk and coffee bean container behind the door.

#### Features

Maintenance-free grinding unit with ceramic discs.  
Separate drawer for second ground coffee type.  
Water pump with 19 bar pressure.  
Double grinding and brewing cycles for extra intensity for single beverage order.  
For double beverage order, two grinding and brewing cycles.  
Beverage dispenser with integrated milk system.  
Insulated stainless steel milk container for up to 0.5 litres.  
Integrated lightning with LEDs.  
Removable bean container with aroma protecting lid for 500 g allows for an effortless exchange of different types of coffee beans.  
Automatic adjustment of ground coffee quantity.  
Removable 2.4 litre water tank.  
Electronic water filter exchange indicator.

Electronic fill level control for drip tray and container for coffee residue.

#### Safety

Child lock.

#### Cleaning

Fully automatic rinse programme when machine is turned on/off.  
Automatic steam cleaning of the milk system after every beverage.  
Automatic cleaning and descaling programme.  
Emptying programme to prepare the appliance for holiday or transportation.  
Empty-grinding function to remove coffee residues from the system when switching bean types.  
Removable brewing unit.

#### Connection

Total connected load 1.6 KW.  
Connection cable 1.7 m with plug.

Left corner installation

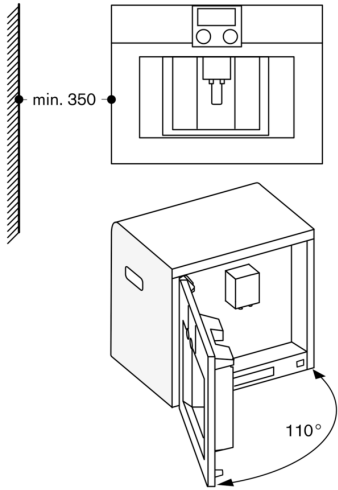

If using the 92° door hinge restrictor (spare part no. 00636455), the minimum distance from the wall is only 100 mm.

