



**CX482100**  
**Full surface induction cooktop 400 series**  
**Frameless**  
**Width 80 cm**

One single big cooking surface  
Free positioning of cookware  
All sizes and formats of cookware can be used  
TFT touch display for an intuitive control of all functions  
Cooking sensor function for temperature control in pots  
Professional cooking functions  
Max. power output for big cookware of up to 5.5 KW  
Frameless for flush mounting

#### Cooking zones

One unique cooking surface of 2750 cm<sup>2</sup>.  
Up to 5 items of cookware can be placed simultaneously on the cooktop.

#### Handling

Easy to use colour graphic TFT touch display with use indications.  
Electronic power control in 17 cooking power levels.

#### Features

Cooking sensor function.  
Professional cooking function.  
Dynamic cooking function.  
Teppan Yaki function.  
Booster function for pots.  
Booster function for pans.  
Keep warm function.  
Individual pot detection.  
Cooking timer for each cooking position.  
Stopwatch.  
Short-term timer.  
Information key with use indicators.  
Power management.  
Cooktop-based ventilation control (with suitable hood).  
Home network integration for digital services (Home Connect) wireless via WiFi.  
The use of the Home Connect functionality depends on the Home Connect services, which are not available in every country. For further information please check: [home-connect.com](http://home-connect.com).

#### Safety

Main switch.  
Residual heat indication.  
Child lock.  
Safety shut-off.  
Pause function.

#### Planning notes

Operates with magnetic (induction) iron pots and pans only. For an optimal heat distribution, the use of sandwich bottom cookware is recommended. The wok pan WP 400 001 cannot be used with this appliance.  
Installation is possible in worktops made of stone, synthetics or solid wood. Heat resistance and watertight sealing of the cut edges must be observed. Concerning other materials please consult the worktop manufacturer.  
The bearing capacity and stability, in the case of thin worktops in particular, must be supported using suitable substructures. Take into account the appliance weight and additional loads. The groove must be continuous and even, so that uniform placing of the appliance on the gasket is ensured. Do not use discontinuous lining.  
Appliance must be fixed from underneath.

#### Characteristics

**Product name/family**  
Cooking zone ceramic

**Construction type**  
Built-in

**Energy input**  
Electric

**Total number of positions that can be used at the same time**  
5

**Type of control setting devices**

**Required niche size for installation (HxWxD)**

**Width of the appliance**  
793

**Dimensions**  
76 x 793 x 513

**Dimensions of the packed product (HxWxD) (mm)**  
152 x 951 x 636

**Net weight (kg)**  
27.200

**Gross weight (kg)**  
29.1

**Residual heat indicator**  
Separate

**Location of control panel**  
Hob front

**Type of external control possibility**

**Basic surface material**  
Color of surface  
anthracite

**Color of frame**

**Approval certificates**  
AENOR, CE

**Length electrical supply cord (cm)**  
150

**EAN code**  
4242006268794

**Electrical connection rating (W)**  
7400

**Gas connection rating (W)**

**Current (A)**

**Voltage (V)**  
220-240

**Frequency (Hz)**  
60; 50

#### Consumption and connection features

2021-07-05  
Page 1

Joint width may vary due to dimensional tolerances of the glass ceramic cooktop and the worktop cut-out.  
Appliance weight: approx. 27. kg

#### Connection

Total connected load 7.4 KW.  
Connecting cable 1.5 m without plug.  
Power consumption standby/display off 0.5 W.  
Power consumption standby/network 2.0 W.  
Please check the user manual for how to switch off the WiFi module.

#### Color Variants

**CX482100**  
**Frameless**  
**Width 80 cm**

#### Included accessories

1 x wireless temperature sensor for cooktop.

#### Optional accessories

**CA060300**  
**Cooking sensor for temperature regulation within pots**  
**GN232110**  
**Teppan Yaki plate made of multi ply material,**  
**GN232230**  
**Teppan Yaki plate made of multi ply material,**

Cross-section

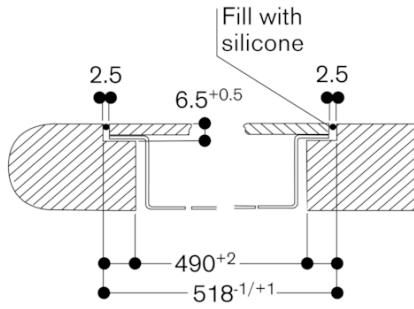

Worktop strength

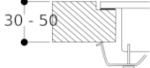

Solid worktop

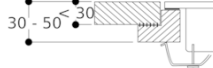

Thin worktop with reinforced substructure

View from above

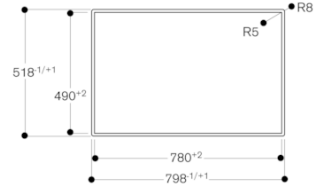

Longitudinal section

