

AA211812

Recirculation module

AA211812

- For air recirculation.
- Can be combined with flat kitchen hood series 200 / canopy extractor series 200.
- Odor reduction comparable to air extraction mode (95%).
- Noise reduction of up to 3 dBA when compared to conventional recirculation filter systems.
- Extended change interval for the activated charcoal filter.

- For air recirculation.

Can be combined with flat kitchen hood series 200 / canopy extractor series 200.

Odor reduction comparable to air extraction mode (95%).

Noise reduction of up to 3 dBA when compared to conventional recirculation filter systems.

Extended change interval for the activated charcoal filter.

For assembly in the upper cabinet.

Consisting of filter housing with design panel, activated charcoal filter, flexible hose and 2 hose clamps.

Top view of top cabinet with AA 211 812

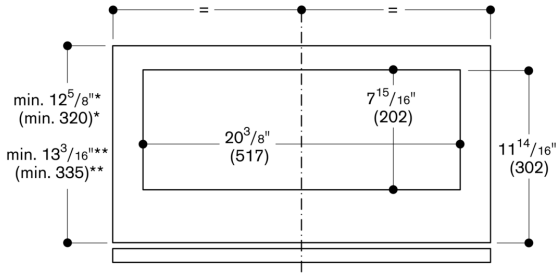

* only appliance
 ** Appliance with lowering frame AA 210 490/460

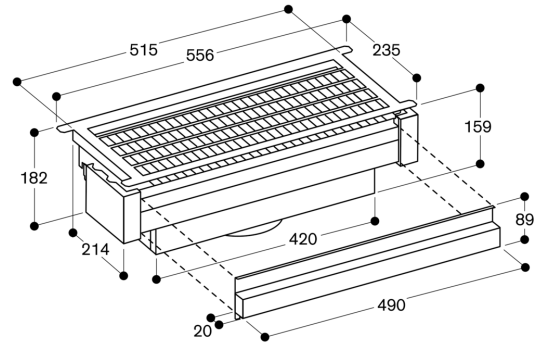

Cross-section top cabinet with AA 211 812 and lowering frame AA 210 490/460

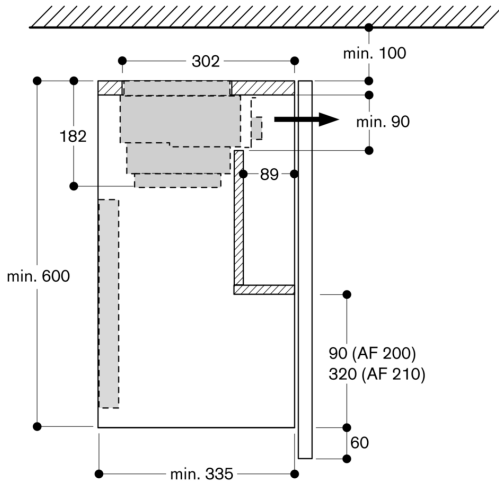

Cross-section top cabinet with AA 211 812

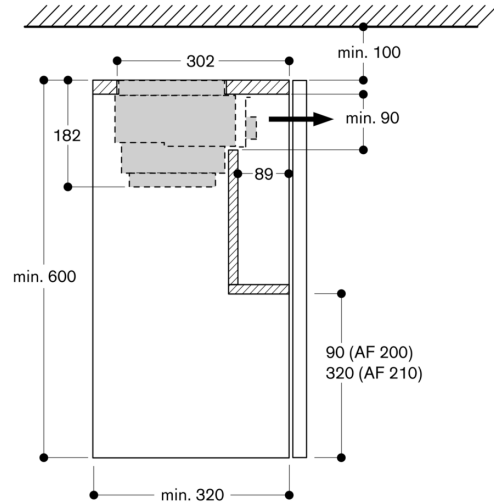

Cross-section top cabinet with AC 200 and AA 211 812

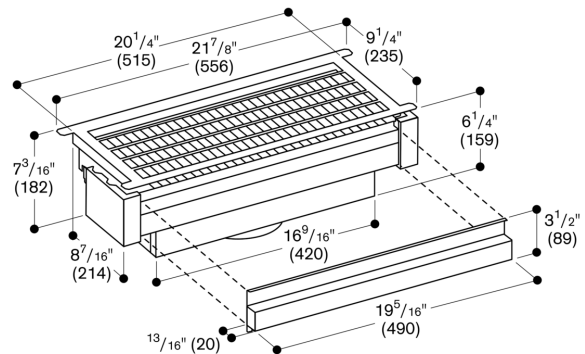
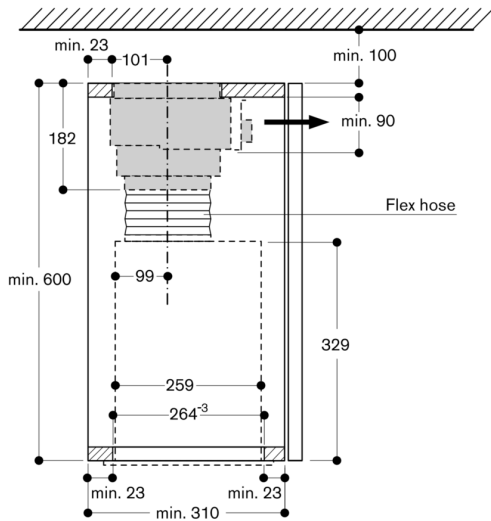

removable filter frame

Cross-section top cabinet with AA 211 812

