



DF481700F

- 1 x baking tray spray head
- 1 x GN container insert
- 1 x holder for long-stemmed glasses

DA043000:

Holder for long-stemmed glasses

DA045061:

3. Basket with smooth running rails

DA020111:

Stainless steel trim kit, 86.5 cm high dw

DA042030:

Silver polishing cassette

DA020110:

Compensating panels, stainless steel

GZ010011:

inlet and outlet hose extension

Dishwasher 400 series
24", Variable hinge for special installation situations

DF481700F

Optimal protection for sensitive glassware by low temperature drying with zeolite, optimized basket design and intelligent water softening
 8 programs with aqua sensor and 6 options, such as Power for cleaning and drying dishes in 57 minutes and Intensive for particularly thorough cleaning in the lower basket

Flexible basket system with smooth running rails on all levels and cushioned closing of the upper and lower baskets

Perfectly illuminated interior

Push-to-open function for perfect integration into custom cabinet fronts

Flexible hinge for reduced toe-kick height as of 1 15/16" (50 mm)

Lateral Info-Light

Very quiet: 42 dB

Operation

TFT display indicating remaining or end time, refill for salt and rinsing agent, inflow of water.
 Touch key operation.

Flexible cycle time reduction, even during an active cycle.

Personalization function for storing individual combinations of programs.

Temporary noise reduction (only available with active Home Connect functionality).

Information key with use indicators.

Sanitized indicator in the control panel.

Time delay up to 24 hours.

Visual and acoustic end of program indicator.

Lateral Info-Light.

Technical Features

Perfectly illuminated interior.

Glass protection with zeolite.

Aqua sensor.

Load sensor.

Automatic detergent function.

Regeneration electronics.

Flow-Through Water Heater™

Triple filter system.

Soft lock.

Aqua stop.

Home network integration for digital services (Home Connect) wireless via WiFi.

The use of the Home Connect functionality depends on the Home Connect services, which are not available in every country. For further information please check: home-connect.com.

Programs

8 programs:

Auto 150-160 °F. Auto 127-140 °F. Auto 113-122 °F. Eco 113-136 °F. Wash and Dry 122 °F. Quick Wash 113 °F (30 min). Glass Care 122 °F. Personalization function (default setting: Pre-rinse).

6 options:

Remote Start Intensive. Power. Sanitize. Extra Dry with zeolite.

Machine Care.

Features

Flexible rack system with smooth running rails

on all levels and soft-closing system of the upper and lower rack.

3rd rack for cutlery.

Upper basket:

Over extension. Optional extra cleaning area by activating additional spray nozzles. Rackmatic with 3 levels, adjustable in height up to 2" (5 cm). 6 folding spines. 4 folding racks for optimal protection of glass.

Lower basket:

8 folding spines. 2 folding racks for optimal protection of glass. Dividable glass support. Cutlery basket.

Holder for long-stemmed glasses.

13 place setting capacity.

Maximum glass loading capacity 23 wine glasses.

Consumption data

Energy Star certified

Total annual energy consumption 269 kWh.

Noise level 42 dB (re 1 pW).

Planning notes

Height-adjustable feet.

Appliance toe-kick recess 3 15/16" (see drawing).

Rear feet adjustable at front.

Door weight up to 22 lb.

Door panel dimension dependent on toe-kick height of kitchen cabinetry.

Installation and usage also with custom cabinet handle possible. The push-to-open function remains active.

Rating

Total rating: 1440 W.

Connection to hot or cold water possible.

Connecting cable 47 1/4" with three-prong plug (NEMA 5-15P).

Dishwasher 34 1/8" (867 mm) with flexible hinge

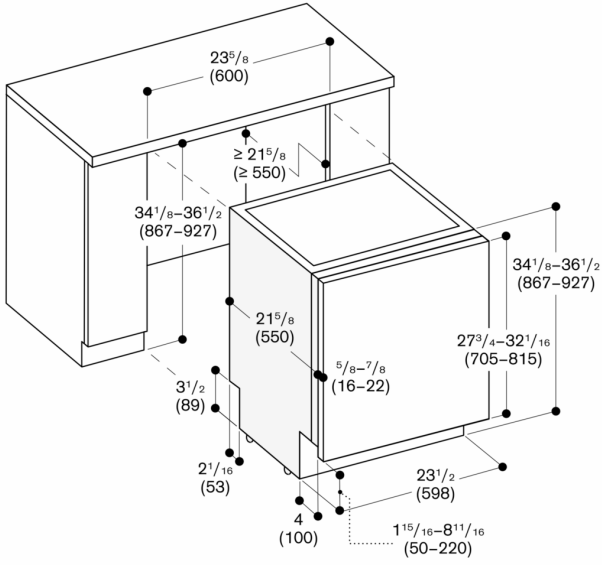

Measurements in inches (mm)

Connection dimensions for a 24" (600 mm) wide dishwasher

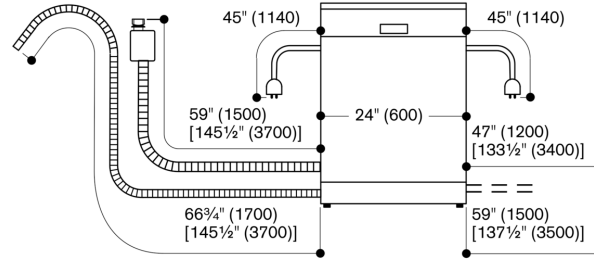

[] values with extension kit
Measurements in inches (mm)