



AW250192

Optional accessories

AA250112:

Activated charcoal filter regenerative

AA250113:

Active carbon filter (spare part)

Installation accessories

AD200012:

Air extraction chimney, stainless steel

Wall-mounted hood 200 series 90 cm, clear glass anthracite printed AW250192

Angled vapour screen provides particularly generous free space above the cooktop

Filter cover with easy to clean glass front

Glass cover fitting to oven 200 series

Energy-saving, low-noise fan

Vapours can be caught efficiently thanks to two suction areas on the underside and front

The glass panel can be extended forward to increase the area for catching vapours during particularly intensive cooking

Function for automatic, sensor-controlled power adjustment depending on the build-up of cooking vapours

Dimmable ambient lighting allows light to be adjusted individually

Air extraction or air recirculation system

Output

Performance and noise level, output level 3/Intensive:

Air output according to EN 61591. Sound power level according to EN 60704-3.

Air extraction:

529 / 990m³/h.

57 / 70 dB (A) re 1 pW.

Air recirculation:

515 / 931m³/h.

68 / 79 dB (A) re 1 pW.

Features

3 electronically controlled power levels and 1 intensive mode.

Automatic function with sensor-controlled run-on function.

Grease filter and activated charcoal filter saturation indicator.

Interval ventilation, 6 min.

Metal grease filter, dishwasher-safe.

Glass filter cover in Gaggenau Anthracite.

2 activated charcoal filters fitted in appliance ex factory.

Highly efficient odour reduction for cooking applications with complex odour molecules (e.g. fish and seafood).

The filter retains an extremely high amount of airborne pollen and deactivates allergens, which are retained by the filter.

Neutral white LED light (3500 K), continuously dimmable.

Lamp output 2 x 3 W.

Illuminance 519 lx.

Indirect LED light (3.000 K), dimmable.

Fan technology with highly efficient, brushless DC motor (BLDC).

Integrated sound insulation for quiet operation.

Easy to clean inner frame.

Easy mounting system for simple installation and alignment.

Selected digital services (Home Connect)

Cooktop-based ventilation control (with suitable cooktop).

Remote control and monitoring.

Remote diagnostics.

Home network integration for digital services (Home Connect) wireless via WiFi.

The use of the Home Connect functionality depends on the Home Connect services, which are not available in every country. For further information please check: home-connect.com.

Consumption data

Energy efficiency class A+ at a range of energy efficiency classes from A+++ to D.

Energy consumption 36.7 kWh/year.

Ventilation efficiency class A.

Illumination efficiency class A.

Grease filter efficiency class B.

Sound level min. 43 dB / max. 57 dB normal mode.

Planning notes

The ventilation appliance is supplied for air recirculation mode only without a chimney. The necessary accessory AD 200 012 is available for potential air extraction mode.

Clearance above gas appliances min. 65 cm (more than total load gas 12 kW min. 70 cm).

Clearance above electric appliances min. 45 cm.

When installing a ventilation hood with air extraction mode and a chimney-vented fireplace, the power supply line of the ventilation appliance needs a suitable safety switch.

Connection

Total connected load 270 W.

Connecting cable 1.3 m with plug.

Power consumption standby/display off 0.5 W.

Please check the user manual for how to switch off the WiFi module.

Side view

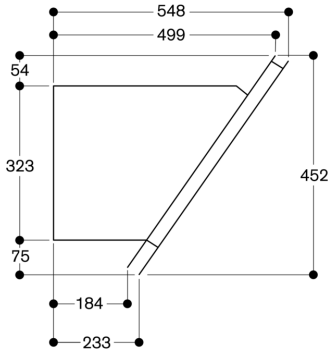

Air extraction

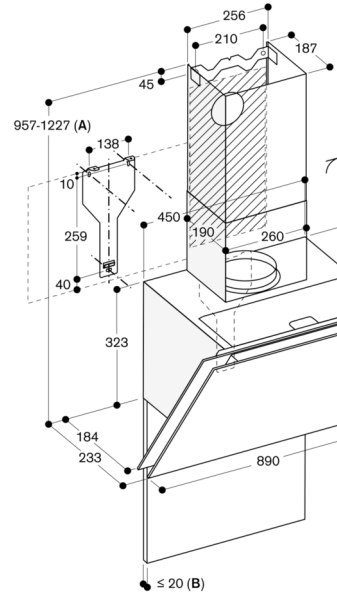

A: Air extraction
 B: Note the maximum thickness of the back panel.
 Socket
 measurements in mm

Air recirculation

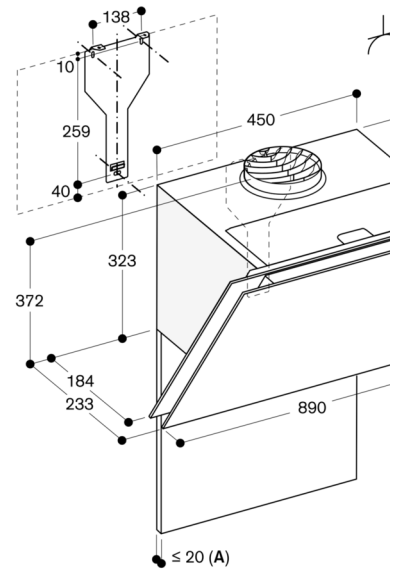

A: Note the maximum thickness of the back panel.
 Socket
 measurements in mm