



Color Variants

CE291111

Sturdy stainless steel frame
Frying sensor function
Three-ring cooking zone up to 27 cm
Large roasting zone
Sensor control with direct selection of output level

Cooking zones

2 Super-Quick cooking zones ø 18 cm (1800 W); together they convert to 18 x 41.5 cm (4400 W) roasting zone.
1 Super-Quick cooking zone ø 12 cm (750 W), converts to ø 21 cm (2100 W, with booster 2600 W) cooking zone.
1 Super-Quick cooking zone ø 14.5 cm (1050 W), converts to ø 21 cm (2200 W) or ø 27 cm (3080 W) cooking zone.
1 Super-Quick cooking zone ø 14.5 cm (1200 W, with booster 1600 W).

Handling

Sensor control with direct selection of output level.
Cooking zone marking.
Electronic power control in 17 output levels.

Features

Frying sensor function for ø 21 cm cooking zone.
Booster function.
Cooking timer for up to 99 minutes.
Short-term timer.
Options menu.

Safety

Main switch.
Operation indicator.
2-stage residual heat indication.
Child lock.
Safety shut-off.

Planning notes

Immersion depth 49 mm, depth at plug socket 50 mm.
Under the plug socket, a 10 mm clearance must be observed from side panels or from intermediate shelf.
The cooktop must be freely accessible from underneath to be able to detach the cooktop's base in a downward direction.
Installation possible in a 60 cm wide lower cabinet.
Appliance must be fixed from underneath.
Cooktop clamping range: 20 - 50 mm.
Appliance weight: approx. 14 kg.

Connection

Total connected load 11.0 KW.
Plan a connection cable.

Characteristics

Product name/family

Cooking zone ceramic

Built-in / Free-standing

Built-in

Energy input

Electric

Total number of positions that can be used at the same time

5

Type of control setting devices

Required niche size for installation (HxWxD)

49 x 880-880 x 490-490

Width of the appliance

908

Dimensions

49x908x520

Dimensions of the packed product (HxWxD)

100x1120x620

Net weight

13.5

Gross weight

15.3

Residual heat indicator

yes

Location of control panel

Front

Type of external control possibility

Basic surface material

Ceramic

Color of surface

Black, Stainless steel

Color of frame

Stainless steel

Length electrical supply cord

Knob Material

Sealed Burners

No

Boost function for pots

Cooking zone front left, Cooking zone rear left

Type of pan support

Natural Gas Connection Rating

LP Gas Connection Rating

Dimension of 1st heating element (in)

Power of heating element (kW)

1200.0

Power of 1st burner

Dimension of 2nd heating element (in)

Power of 2nd heating element (kW)

Power of 2nd burner

Dimension of 3rd heating element (in)

Power of 3rd heating element (kW)

800.0 ; 2100.0

Power of 3rd burner

Dimension of 4th heating element (in)

Power of 4th heating element (kW)

Power of 4th burner

Dimension of 5th heating element (in)

Power of 5th heating element (kW)

1800.0 ; 4400.0

Power of 5th burner

Dimension of 6th heating element (in)

Power of heating element (kW in boost)

[1.6]

Power of 3rd heating element (kW in boost)

[2.6]

Power of 4th heating element (kW in boost)

[1.6]

Power of 5th heating element (kW in boost)

[1.6]

Power of 6th heating element (kW in boost)

[1.6]

Power of 6th heating element (kW in boost)

[1.6]

Connection Rating

11000

Gas connection rating

Fuse protection

3*20

Voltage

220-240

Frequency

50

Universal Product Code

Energy input

Electric

Gas type preset

Certified gas types

Length of electrical supply cord (in)

GAGGENAU

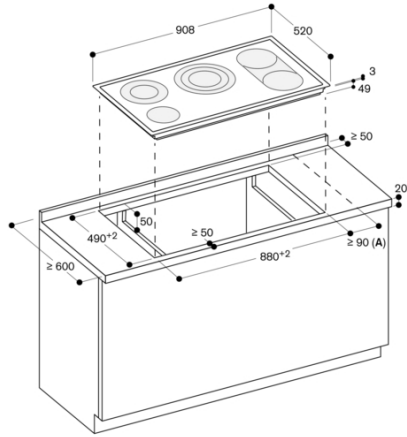

A: Minimum distance from the hob cut-out to the wall.
measurements in mm