



**RC200202**  
**Refrigerator 200 series**  
**Fully integrated, under-counter**  
**Niche width 60 cm, Niche height 82 cm**



Combines with freezer RF 200 (Side-by-side)  
 Cushioned door closing system allowing a soft and controlled door closure  
 Net volume 137 litres

**Technical Features**  
 Automatic defrosting with defrost water evaporation.  
 Cushioned door closing system from 20° door opening angle, integrated in door hinge.

**Cooling**  
 3 safety glass shelves, 2 of which height adjustable.  
 1 pull-out drawer.  
 1 vegetable compartment.  
 1 large door rack for bottles.  
 2 door racks.  
 Bright interior lighting.  
 Net volume 137 litres.

**Consumption data**  
 Energy efficiency class A++ at a range of energy efficiency classes from A++ to D.  
 Energy consumption 92 kWh/year.  
 Noise level 38 dB (re 1 pW).

**Planning notes**  
 Flat hinge.  
 Door hinge right, reversible.  
 Door opening angle of 115°, fixable at 90°.  
 Max. door panel weight 14 kg.  
 Height-adjustable feet.  
 Plinth height for niche height of 820 mm: 100 - 170 mm.  
 Plinth height for niche height of 870 mm: 150 - 220 mm.  
 The enclosed ventilation grille must be used.  
 The mains socket needs to be planned outside the built-in niche.

**Connection**  
 Total connected load 0.090 KW.  
 Connecting cable 2.3 m with plug.

**Color Variants**

**RC200202**  
**Fully integrated, under-counter**  
**Niche width 60 cm, Niche height 82 cm**

**Included accessories**

1 x egg tray.

**Optional accessories**

**RA430100**  
**Storage container with transparent lid, anthracite.**

**Characteristics**

**Energy Efficiency Class (Regulation (EU) 2017/1369)**  
 F

**Average annual energy consumption in kilowatt hour per year (kWh/a) (EU) 2017/1369**  
 114

**Sum of volume of frozen compartments (EU 2017/1369)**  
 0

**Sum of volume of chill compartments (EU 2017/1369)**  
 137

**Airborne acoustical noise emissions (EU 2017/1369)**  
 38

**Airborne acoustical noise emission class (EU 2017/1369)**  
 C

**Built-in / Free-standing**  
 Built-in

**Number of compressors**  
 1

**Number of independent cooling systems**  
 1

**Width of the appliance**  
 598

**Height (mm)**  
 820

**Depth of the product**  
 548

**Net weight (kg)**  
 33.176

**Required niche size for installation (HxWxD)**  
 820 x 600 x 550

**Door panel options**  
 Possible but accessory

**Door hinge**  
 Right reversible

**Number of Adjustable Shelves in fridge compartment**  
 3

**Shelves for Bottles**  
 No

**Frost free system**  
 No

**Interior ventilator**  
 No

**Reversible Door Hinge**  
 Yes

**Length electrical supply cord (cm)**  
 230

**Noise level (dB)**  
 38

**Multi-Flow Air Tower**  
 No

**Economy setting**  
 No

**Cold technology**  
 1 compressor/1 cold circuit

**Fast cooling switch**  
 No

**Temperature Controlled Drawer**  
 No

**Humidity Control Drawer**  
 No

**Number of Door Bins - Refrigerator**  
 3

**Door bin adjustability - Refrigerator**  
 No

**Tilt-out door bins in fridge**  
 Yes

**Gallon Storage**  
 Yes

**Number of Gallon storage**  
 1

**No. of shelves in fridge**  
 3

**Motorized Shelf**  
 No

**Material of the shelves**  
 Type of Light

**Door opened indicator freezer**  
 No

**Connection rating (W)**  
 90

**Current (A)**  
 10

**Voltage (V)**  
 220-240

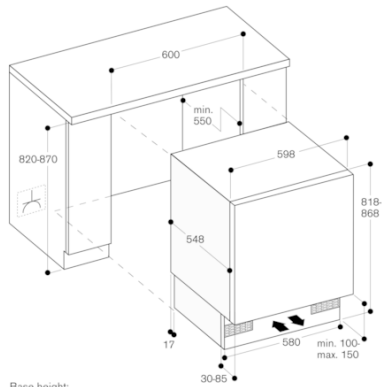
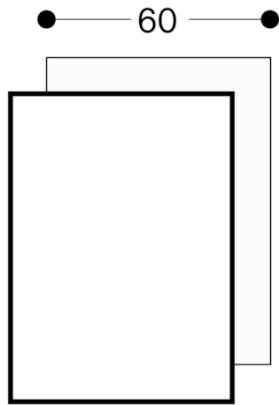

Base height:  
- 100 mm when niche height is 820 mm  
- 150 mm when niche height is 870 mm