



RF200202
Freezer 200 series
Fully integrated, under-counter
Niche width 60 cm, Niche height 82 cm



Combines with cooler RC 200 (Side-by-side)
 Cushioned door closing system allowing a soft and controlled door closure
 Net volume 98 litres

Technical Features

Cushioned door closing system from 20° door opening angle, integrated in door hinge.
 Malfunction signal.

Freezing

Fast freezing.
 Temperature range adjustable.
 4-star freezer compartment.
 Freezing capacity 12 kg/24 h.
 Storage time after a malfunction 23 h.
 3 freezer drawers.
 Net volume 98 litres.

Consumption data

Energy efficiency class A+ at a range of energy efficiency classes from A+++ to D.
 Energy consumption 184 kWh/year.
 Noise level 38 dB (re 1 pW).

Planning notes

Flat hinge.
 Door hinge right, reversible.
 Door opening angle of 115°, fixable at 90°.
 Max. door panel weight 14 kg.
 Height-adjustable feet.
 Plinth height for niche height of 820 mm: 100 - 170 mm.
 Plinth height for niche height of 870 mm: 150 - 220 mm.
 The enclosed ventilation grille must be used.
 The mains socket needs to be planned outside the built-in niche.

Connection

Total connected load 0.090 KW.
 Connecting cable 2.3 m with plug.

Color Variants

RF200202
Fully integrated, under-counter
Niche width 60 cm, Niche height 82 cm

Included accessories

2 x cold accumulator.
 1 x ice cube tray.

Characteristics

Energy Efficiency Class (Regulation (EU) 2017/1369)
 F

Average annual energy consumption in kilowatt hour per year (kWh/a) (EU) 2017/1369
 224

Sum of volume of frozen compartments (EU 2017/1369)
 106

Airborne acoustical noise emissions (EU 2017/1369)
 38

Airborne acoustical noise emission class (EU 2017/1369)
 C

Product category
 Upright freezer

Built-in / Free-standing
 Built-in

Color / Material body

Frost free system
 No

Climate class
 SN-ST

Door panel options
 Possible but accessory

Width of the appliance
 598

Depth of the product
 548

Dimensions of the packed product (HxWxD) (mm)
 890 x 610 x 670

Required niche size for installation (HxWxD)

Warning signal / malfunction
 visual and audible

Defrost process
 manual

Cover door installation system
 Fixed-mounted

Number of drawers/baskets (Stck)
 3

Number of freezing flaps (Stck)
 0

Lockable door
 No

Thermometer freeze section
 Analog

Light
 No

Length electrical supply cord (cm)
 230

Door hinge
 Right reversible

Net weight (kg)
 35.550

Gross weight (kg)
 38.5

Multi-Flow Air Tower
 No

Number of compressors
 1

Number of independent cooling systems
 1

Economy setting
 No

Fast freezing switch
 Yes

Number of Door Bins - Freezer

Door bin adjustability - Freezer
 No

Tilt-out door bins in freezer
 No

Number of shelves - Freezer

Door bin adjustability - Freezer
 No

Shelf Material - Freezer

Reversible Door Hinge
 Yes

Connection rating (W)
 90

Fuse protection (A)
 10

Frequency (Hz)
 50

Approval certificates
 CE, G-Mark, VDE

Energy consumption (kWh)
 Total annual energy consumption (kWh)

GAGGENAU

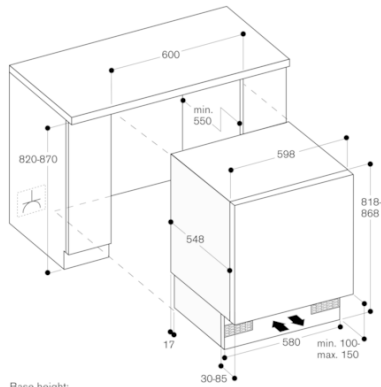
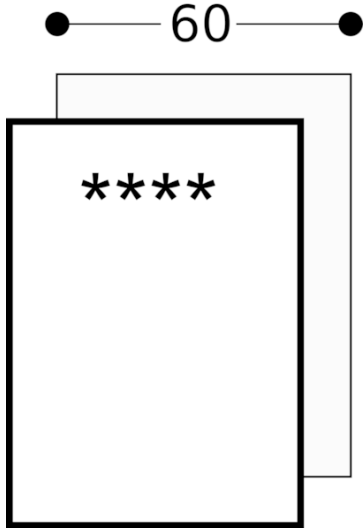

Base height:
- 100 mm when niche height is 820 mm
- 150 mm when niche height is 870 mm