



RT200202
Fridge-freezer combination 200 series
Fully integrated, under-counter
Niche width 60 cm, Niche height 82 cm

Cushioned door closing system allowing a soft and controlled door closure
 Net volume 123 litres

Technical Features

Cushioned door closing system from 20° door opening angle, integrated in door hinge.

Cooling

Automatic defrosting with defrost water evaporation.

2 safety glass shelves, 1 of which height adjustable.
 1 pull-out drawer.
 1 vegetable compartment.
 1 large door rack for bottles.
 2 door racks.
 Bright interior lighting.
 Net volume 108 litres.

Freezing

Storage temperature -18 °C and lower.
 4-star freezer compartment.
 Freezing capacity 2 kg/24 h.
 Storage time after a malfunction 10 h.
 Net volume 15 litres.

Consumption data

Energy efficiency class A++ at a range of energy efficiency classes from A++ to D.
 Energy consumption 140 kWh/year.
 Noise level 38 dB (re 1 pW).

Planning notes

Flat hinge.
 Door hinge right, reversible.
 Door opening angle of 115°, fixable at 90°.
 Max. door panel weight 14 kg.
 Height-adjustable feet.
 Plinth height for niche height of 820 mm: 100 - 170 mm.
 Plinth height for niche height of 870 mm: 150 - 220 mm.
 The enclosed ventilation grille must be used.
 The mains socket needs to be planned outside the built-in niche.

Connection

Total connected load 0.090 KW.
 Connecting cable 2.3 m with plug.

Characteristics

Built-in / Free-standing
 Built-in

Number of compressors
 1

Number of independent cooling systems
 1

Width of the appliance
 598

Height
 820

Depth of the product
 548

Net weight
 33.833

Required niche size for installation (HxWxD)
 820 x 600 x 550

Door panel options
 Possible but accessory

Door hinge
 Right reversible

Number of Adjustable Shelves in fridge compartment
 1

Shelves for Bottles
 No

Frost free system
 No

Interior ventilator
 No

Reversible Door Hinge
 Yes

Length electrical supply cord
 230

Noise level
 38

Multi-Flow Air Tower
 No

Economy setting
 No

Cold technology
 1 compressor/1 cold circuit

Fast cooling switch
 No

Temperature Controlled Drawer
 No

Humidity Control Drawer
 No

Number of Door Bins - Refrigerator
 3

Door bin adjustability - Refrigerator
 No

Tilt-out door bins in fridge
 Yes

Gallon Storage
 Yes

Number of Gallon storage
 1

No. of shelves in fridge
 2

Motorized Shelf
 No

Material of the shelves
 Type of Light

Door opened indicator freezer
 No

Connection rating
 90

Fuse protection
 10

Voltage
 220-240

Frequency
 50

Energy consumption
 Freezing capacity

Energy efficiency rating
 Energy consumption annual - NEW (2010/30/EC)
 140.00

Refrigerator Net capacity - NEW (2010/30/EC)
 108

Freezer Net capacity - NEW (2010/30/EC)
 15

Frost free system
 No

Freezing capacity) - NEW (2010/30/EC)
 2

Storage Period in Event of Power

Color Variants

RT200202
Fully integrated, under-counter
Niche width 60 cm, Niche height 82 cm

Included accessories

1 x egg tray.
 1 x ice cube tray.

Optional accessories

RA430100
Storage container with transparent lid, anthracite.

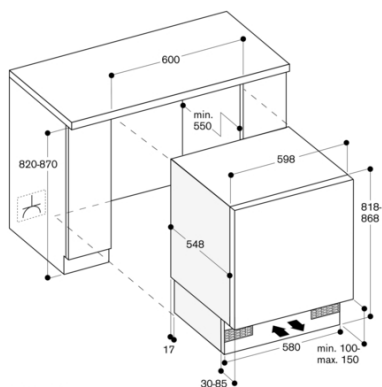
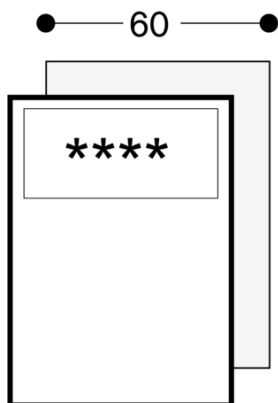

Base height:
- 100 mm when niche height is 820 mm
- 150 mm when niche height is 870 mm