



RW222263

Optional accessories

RA050220:

Carbon airfilter

wine climate cabinet 200 series

122 x 56 cm

RW222263

- Humidity level can be increased to avoid drying out of cork
 - Two independently controllable climate zones from 5° to 20°
 - 2 independently controllable climate zones.
- Consistent temperatures with exact control from +5 °C to +20 °C.
Humidity control.
Extendable bottle trays in beech and aluminium
Presentation light option
Low-vibration operation
Number of standard wine bottles: 48

Handling

Electronic temperature control with digital display.
Touch keys.
Presentation light option in each climate zone, dimmable.
Interior LED lighting (3000 K) with automatic dimming with opening and closing of door.

Technical features

Dynamic cold air distribution.
Automatic defrosting with defrost water evaporation.
Cushioned door closing system integrated in door hinge.
1 activated charcoal air filter for both climate zones.
UV-protection.
Open-door and malfunction alarm.
Child lock.

Features

Capacity 48 bottles (based on 0.75 l standard bottles).
6 bottle trays, thereof 4 extendable.
Storage of magnum bottles possible.
LED lighting.
Total volume: 159 litres.

Consumption data

Energy efficiency class G at a range of energy efficiency classes from A to G.
Energy consumption 151 kWh/year.
Noise level 32 dB (A) re 1 pW.

Planning notes

Flat hinge.
Door hinge right, reversible.
Height-adjustable feet.
Door opening angle of 115°, fixable at 90°.
Max. door panel weight 20 kg.
Door panel thickness min. 16 mm / max. 22 mm.
The mains socket needs to be planned outside the built-in niche.
For a side-by-side installation every appliance must be planned in its own niche.
The wine climate cabinet can be combined with a second wine climate cabinet or a freezer (RF 287 or RF 282) only. If combining the wine climate cabinet with other cooling appliances (RC, RT, RB), a clearance of min. 150 mm is to be kept between the appliances to avoid condensation.

No transport/operation above 1500 m sea level.

Connection

Total connected load: 0.130 KW.
Connecting cable 2.0 m with plug.

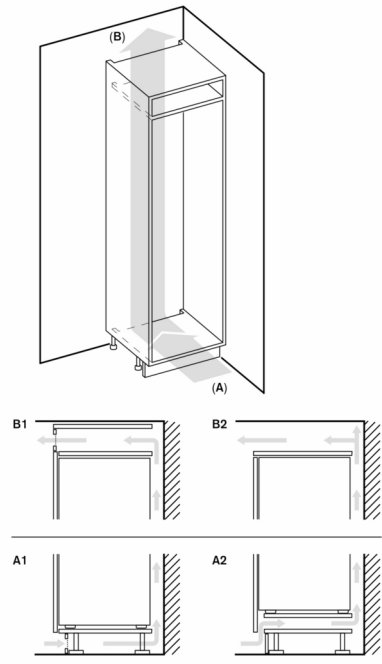

A: Air inlet $\geq 200 \text{ cm}^2$; ventilation options A1 or A2
 B: Air outlet $\geq 200 \text{ cm}^2$; ventilation options B1 or B2

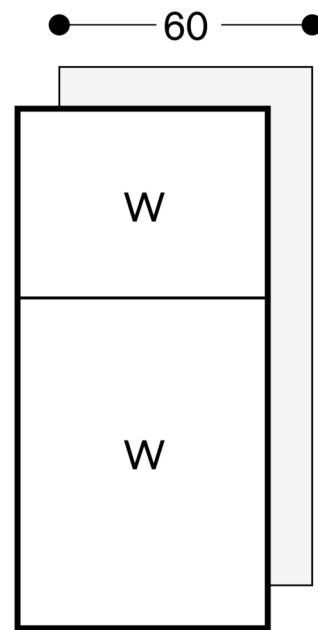

Bottle storage

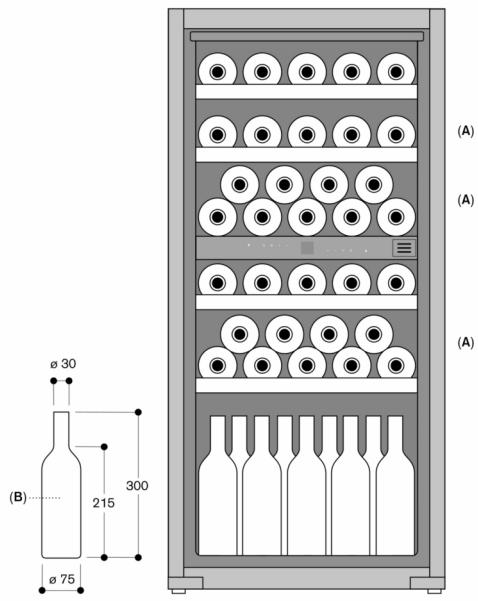

A: Suitable area for storage of magnum bottles in standard tray configuration
 B: 0.75 litres
 Measurements in mm

