



Color Variants

VG231334HK
Aluminium control panel
Width 28 cm

Optional accessories

VD201034
Shot-blasted aluminium appliance cover
WP400001
Wok pan made of multiple-layer material

VG231334HK
Vario gas wok 200 series
Aluminium control panel
Width 28 cm
Town gas 10 mbar
Wok burner with up to 6 KW

Can be combined with the cooktops of the Vario 200 series to a harmonic unity

Generous control panel for comfortable and secure operation
Three-ring burner of solid, heat-resistant brass as used in professional kitchen
Total output up to 6 KW

Cooking zones

1 three-ring wok burner (250 W – 6,000 W), suitable for pots up to max. ø 32 cm.

Handling

One-handed operation.
Electric ignition.
To close the cover, the cast iron pan support can be easily reversed.

Features

Cast iron pan support.
Brass burner rings.

Safety

Thermoelectric safety pilot.

Planning notes

Maximum drawer depth 42 cm.
Appliance can be snapped into the worktop from above.
A minimum clearance of at least 150 mm from adjacent heat-sensitive furniture or contact surfaces must be observed or thermal insulation fitted.
With a total connected load of more than 11 kW local regulations concerning room ventilation, room size and combination of extraction or recirculation hoods must be observed.
Minimum clearance between gas cooktop(s) with more than 11 kW and ventilation hood 70 cm.
Appliance weight: approx. 9 kg.

Connection

Total connected load gas 6.0 kW.
Total connected load electric 1.0 W.
Connecting cable 2.0 m with plug.

Characteristics

Product name/family
Vario/Domino gas hob w control
Built-in / Free-standing
CONSTR_TYPE.Built-in
Energy input
Gas
Total number of positions that can be used at the same time
1
Required niche size for installation (HxWxD)
88 x 268 x 490
Width of the product (mm)
288
Dimensions of the product (mm)
88 x 288 x 523
Dimensions of the packed product (HxWxD) (mm)
230 x 410 x 600
Net weight (kg)
8.620
Gross weight (kg)
10.0
Residual heat indicator
without
Location of control panel
Hob front
Basic surface material
brushed stainless steel
Color of surface
Stainless steel
Color of frame
Stainless steel
Approval certificates
VDE
Length electrical supply cord (cm)
200

Consumption and connection features

Electrical connection rating (W)

1

Gas connection rating (W)

6000

Current (A)

10

Voltage (V)

220-240

Frequency (Hz)

50; 60

2019-10-23

Page 1

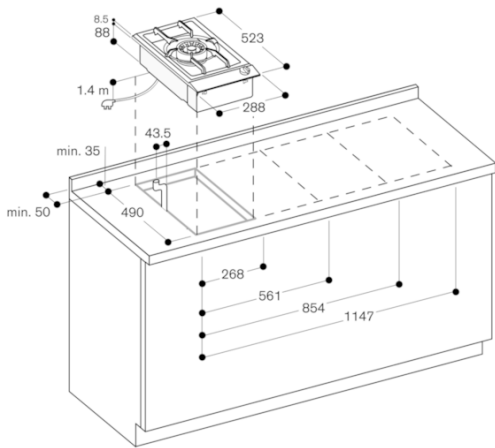
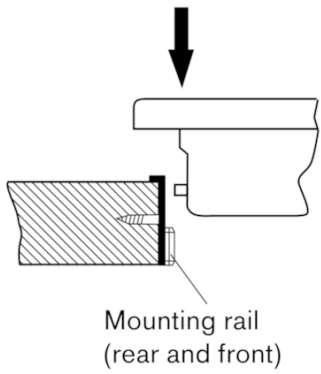

Gas connection

