



VI232120

Included accessories

1 x glass scraper

Optional accessories

GP900001:
System pan diameter 15 cm

GP900002:
System pan diameter 19 cm

GP900003:
Frying sensor pan Ø 21 cm

VD200020:
Black cover series 200

Installation accessories

VV200010:
Connecting strip series 200 ss

VV200020:
Connecting strip series 200 black

Vario flex induction cooktop 200 series 28 cm

VI232120

Can be combined with the cooktops of the Vario 200 series to a harmonic unity
Control panel for comfortable and secure operation

Cooking zones

2 flex induction cooking areas 21x19 cm (2200 W, with booster 3700 W), linked together 21x38 cm (3300 W, with booster 3700 W).

Handling

Control knobs with illuminated ring.
Integrated control panel.
Electronic power control in 9 output levels.

Features

Cooking area marking.
Flex function for rectangular cooking areas.
Frying sensor function.
Pot detection.
Booster function for both cooking areas.

Safety

Residual heat indication.
Operation indicator.
Safety shut-off.

Planning notes

Operates with magnetic (induction) iron pots and pans only. For an optimal heat distribution, the use of sandwich bottom cookware is recommended.
Appliance can be snapped into the worktop from above.
Appliance weight: approx. 9 kg.

Connection

Total connected load 3.7 KW.
Connecting cable 1.5 m without plug.

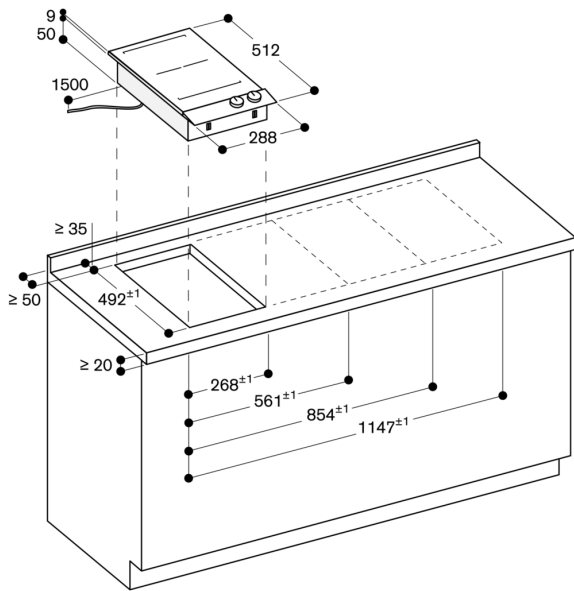

measurements in mm