



Color Variants

WM260162CN

Free-standing, slide-under or stackable

Width 60 cm, height 84.8 cm

WM260162CN

Washing machine

Free-standing, slide-under or stackable

Width 60 cm, height 84.8 cm

Intelligent dosage system iDos for automatic in-flow control of liquid detergent and softener
 9 kg drum with interior lighting
 Large porthole with 180 ° door opening angle
 Innovative BLDC motor technology for more performance, higher durability as well as less energy consumption and noise
 Stain Automatic for stain specific programme cycles
 Can be perfectly combined with WT 260 110 CN
 Energy efficiency class 1

Handling

Electronic control.
 Illuminated rotary knob with integrated On-Off switch.
 Touch key operation.
 TFT display with clear text and symbols.
 Loading indicator with dosage recommendation.
 Programme sequence and remaining time display.
 Time delay up to 24 hours.
 Multiple signal tones.

Technical Features

Aqua sensor.
 Aqua stop with guarantee.
 Flow-through sensor.
 Anti-stain automatic.
 Continuous automatic load adjustment.
 Foam detection system.
 Spin speed selection from 400 to 1600 rpm.
 Top-up function.
 Automatic stabilisation.
 Anti-crease system.
 Child lock.

Programmes

Cottons, cold to 90 °C.
 Synthetics, cold to 60 °C.
 Quick/Mix, 40 °C.
 Delicates/Silk, cold to 40 °C.
 Wool, cold to 40 °C.
 Denim.
 Outdoor.
 Super 15.
 Shirts/blouses.
 Hygiene.
 Disinfectant.
 Automatic Soft.
 Automatic.
 Additional programmes: Down, Towels, Rinse/Freshen Up, Spin, Low Spin, Drain.

Features

Powder detergent drawer with automatic cleaning mode after every wash cycle.
 2 iDos tanks with 1.3 and 0.5 l capacity for liquid detergent or softener.
 Stainless steel drum with wave structure.
 Drum interior lighting.
 Volume capacity from 1 to 9 kg.

Consumption data

Energy efficiency class 1.

Planning notes

Left-hinged.
 Height-adjustable feet.
 Height for slide-under installation: 85 cm.
 Stackable under the tumble dryer WT 260 110 CN in combination with special accessory.

Connection

Characteristics

Built-in / Free-standing

Free-standing

Door hinge

Left

Color / Material body

White

Length electrical supply cord (cm)

160

Height for building under

850.00

Height of the product (mm)

848

Dimensions of the product (mm)

848 x 598 x 590

Wheels

No

Net weight (kg)

77.533

Drum volume (l)

60

Capacity cotton (kg)

9.0

Universal Product Code

Main colour of product

White

Door Frame

silver-white

Color Buttons

satined alu, white

Color Dial

satined alu

Alternative colors available

Noise level washing (dB(A) re 1 pW)

43

Connection Rating (W)

2300

Current (A)

10

Voltage (V)

220

Frequency (Hz)

50

Total annual energy consumption (kWh)

Total annual water consumption (gal)

Energy Star Qualified

Cord Included

Yes

Length of electrical supply cord (in)

Plug type

China plug

Length of drain hose (in)

59.05

Length of supply hose (in)

59.05

Appliance Dimensions (h x w x d)

(inches)

x x

Dimensions of the packed product (in)

34.44 x 25.98 x 27.16

Net weight (lbs)

171

Gross weight (lbs)

173

Capacity (cu. ft.)

Length of drain hose

150.00

Length of supply hose

150.00

Dimensions of the packed product

(HxWxD) (mm)

875 x 690 x 660

Gross weight (kg)

78.5

Power consumption standby/network:

Please check the user manual for how to switch off the WiFi module.

Time auto-standby/network

Consumption and connection features

Connection Rating (W)

2300

Current (A)

10

Voltage (V)

220

Frequency (Hz)

50

Approval certificates

CCC, CCC, CE, VDE

Energy consumption (kWh)

Total connected load 2.3 kW.

Connection cable 1.60 m with plug.

Water connection with 3/4" screw joint.

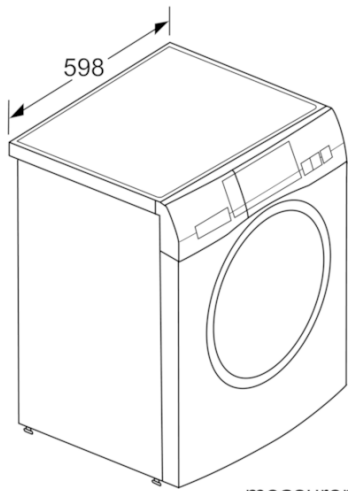

measurements in mm

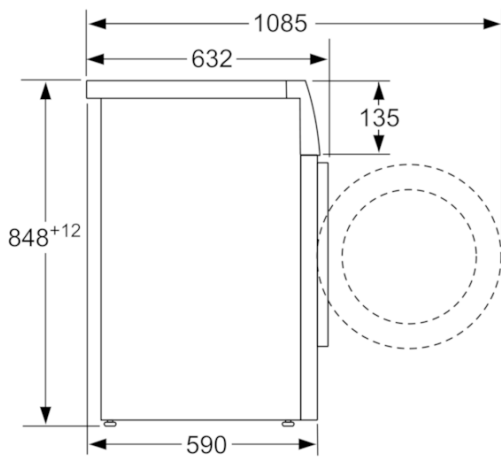

measurements in mm